

Baxi FS 801 RS

GC No. 41 077 30

Baxi FS 801S RS

GC No. 41 077 27

Baxi FS 701 RS

GC No. 41 077 29

Baxi FS 701S RS

GC No. 41 077 26

Baxi FS 601 RS

GC No. 41 077 28

Baxi FS 601S RS

GC No. 41 077 25

Central heating boilers

Cat. 1N

**Installation and
Service Instructions**

Installation Instructions

Introduction

This is a range of floor standing, open flue boilers with the option of a standard model or an 'S' version which incorporates a programmer in the fascia panel.

There is a choice of outputs listed below:

Boiler Type	Heat output	
	kW	Btu/h
FS 801 RS FS 801S RS	20.8 to 23.4	71,000 to 80,000
FS 701 RS FS 701S RS	17.8 to 20.5	61,000 to 70,000
FS 601 RS FS 601S RS	14.9 to 17.6	51,000 to 60,000

The boilers share a common outer case within which there is adequate space to fit a central heating pump using standard fittings. The standard version only may be fitted under a work top and an optional extra top panel is available for this purpose. The pump cannot be fitted in the case in this type of application (See PUMP).

All appliances are designed for use on Natural Gas only. Each appliance consists essentially of three components, namely:

1. Combustion chamber with heat exchanger, burner, controls and inlet of air duct.
2. Outer case. (Control Panel — packed separately.)
3. Balanced flue terminal (packed separately).

An optional extra top panel is available in order that the appliance may be installed under a work top — This panel is only available for the standard models and must not be used with the 'S' versions. When this panel is used to install the appliance underneath a work top then it is not possible to fit the pump within the outer case.

Installation Requirements

General

The installation must be carried out by a competent installer and be in accordance with relevant BS Codes of Practice, I.E.E. Regulations, Gas Safety Regulations, Building Regulations, and by-laws of the Local Water Undertaking. References should be made to BS Codes of Practice 331 — part 3, BS 6798, and BS 5440 Part 1 & 2, 5449 Part 1.

Siting

These boilers must be fitted on a suitable outside wall, the position permitting a satisfactory flue and an adequate air supply.

A new or existing cupboard or compartment used to enclose the boiler must be constructed specifically for this purpose. Details of essential features of cupboard/compartment design are given in BS 5376:2.

Clearances

for air movement, case removal and spanner access.

	Above outer case top	Sides
When free standing	13mm (½in)	No clearance necessary
	Above optional top panel	

When under work top* 25mm (1in) 10mm (¾in) each side

*minimum height to underside of work top 875mm (34½in).

Ventilation

Detailed recommendations for air supply are given in BS 5440:2.

The room in which the boiler is installed does not require a purpose provided air vent. When the boiler is installed in a purpose made cupboard, air vents are required (for cooling purposes) at high and low level. These vents may communicate with a room or direct to outside air.

The minimum effective area requirements of cupboard/compartment air vents are as indicated below.

Flue arrangement

A range of flue ducts is available to suit different wall thicknesses.

Wall thickness

1. 286mm to 371mm (11¼in) (14⅝in) This is the standard length supplied with the boiler.
2. 108mm to 286mm (4¼in) (11¼in) When using this flue duct both the outer and inner ducts on the flue terminal must be shortened when the wall thickness is less than 200mm (7⅞in).
3. 317mm to 457mm (14⅝in) (18in)

The balanced flue terminal is designed such that it must be fitted from inside the building.

1. The air inlet/products ducts must be square and horizontal to the inner wall face.
2. The hole size required for the flue is: 275mm wide x 345mm high (10⅞in) (13⅝in)
3. A trim is supplied which may be fitted around the terminal.

Appliance	Air from Room	Air direct from Outside	Position of Vents
FS 801 RS FS 801S RS	271cm ² (42in. ²)	136cm ² (21in. ²)	AT HIGH
FS 701 RS FS 701S RS	235cm ² (36in. ²)	118cm ² (18in. ²)	LEVEL AND ALSO AT
FS 601 RS FS 601S RS	207cm ² (32in. ²)	104cm ² (16in. ²)	LOW LEVEL

Balanced flue siting requirements

The following guidelines indicate the requirements for siting of balanced flue terminals:

1. On a clear expanse of outside wall, preferably not less than 600mm (2ft) from a corner, recess or projection.
2. Not less than 300mm (1ft) vertically beneath an openable window or ventilator.
3. Not less than 600mm (2ft) from any surface facing the terminal.
4. Not less than 300mm (1ft) above ground level.
5. Not immediately beneath eaves or a balcony.
6. If the terminal is less than 2m (6ft) above the ground or a balcony to which people have access the terminal should be protected by a guard.
7. If the outer surface of an outside wall is of combustible material it should be protected by fitting a non-combustible plate which extends not less than 50mm (2in) around the terminal.

A terminal guard is available as an optional extra and may be obtained from:

SOUTH — Tower Flue Components Ltd, Vale Rise, Tonbridge, Kent TN9 1RA

NORTH — Tower Flue Components Ltd, 236 Lockwood Road, Lockwood, Huddersfield HD1 3TG. Tel. 0484 47916

When ordering a terminal guard always quote the appliance name.

Water circulation systems (see pages 8 & 9)

The appliances are only suitable for connection to a cistern supply and can be used with:-

1. Pumped domestic hot water and pumped central heating systems.
2. Gravity flow domestic hot water and pumped central heating systems.
 - (a) With 28mm pipes the minimum circulating head for gravity domestic hot water should not be less than 1m (3ft 3in) measured vertically from the flow connection on the boiler to the flow connection on the cylinder. At this head, the maximum horizontal distance measured along the run of the pipe should not exceed 3m (10ft). Greater horizontal distances and smaller pipe sizes are acceptable with suitably increased heads. Allowances must be made for pipe bends where necessary.
 - (b) If the above conditions are not easily met then pumped primaries should be used.
 - (c) Gravity flow and return pipes should be laid to maximum fall to avoid air locks.

The following points are of particular importance:

1. THE WATER SPREADER MUST BE FITTED TO THE PUMPED RETURN CONNECTION ON ALL SYSTEMS.
2. The appliances must not be used on sealed systems.
3. The system must be designed to avoid reverse circulation.
4. The static head must not exceed 30m (100ft) of water.
5. The boilers must only be used with an indirect cylinder when domestic hot water is required.

6. Drain points should be fitted at the lowest points in the system.
7. The system must be designed such that gravity circulation in the heating system does not take place when the pump is not running.

Gas supply

The gas connection is located at the bottom left hand side of the appliance and is Rc $\frac{1}{2}$ ($\frac{1}{2}$ in B.S.P.T. internal). Ensure that the pipework from the meter to the appliance is of adequate size. Do not use pipes of a smaller size than the appliance gas connection.

Electrical supply

External wiring must be correctly earthed and polarised and in accordance with I.E.E. regulations.

For wiring instructions see 'Electrical Connections'.

Appliance details (all appliances)

Height	900mm (35 $\frac{1}{2}$ in)
Width	395mm (15 $\frac{1}{2}$ in)
Forward projection from the wall	535mm (21in)
Weight empty	97kg (214lbs)
Water content	7 litres (1.54 gallons)
Boiler tapplings	4 × Rp1 (1in BSP internal) and 1 × Rp $\frac{3}{4}$ ($\frac{3}{4}$ in BSP internal)
Electrical supply	240v ~ 50 Hz — 3 amp fuse
Gas connection	Rc $\frac{1}{2}$ ($\frac{1}{2}$ in BSPT internal)
Max. working head	30m (100ft)
Thermocouple output	10-15mv.

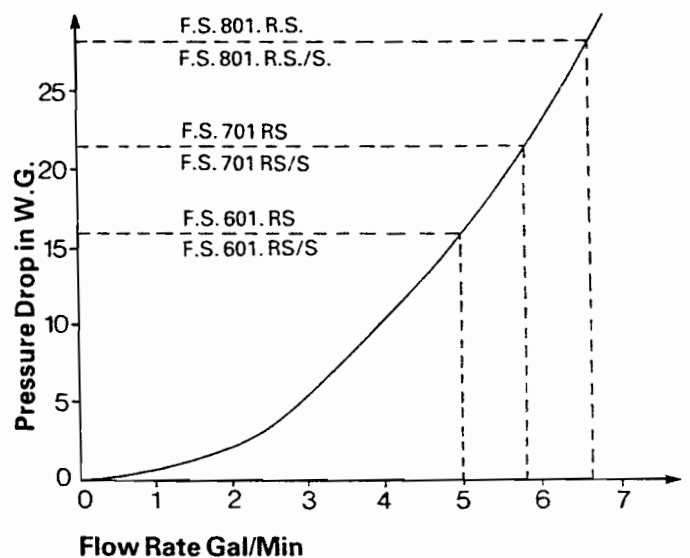

Hydraulic resistance chart

Fitting the Appliance

1. Ensure that the floor is sound and level.
2. Ensure that the length of the flue terminal is suitable for the wall thickness.
3. Select the most suitable position for the boiler (Figs 1 & 4).
4. Mark the position of the flue opening.
5. Cut out the hole for the flue.
6. Measure the wall thickness, assemble the flue terminal to the back of the appliance and adjust until the dimension from the back of the inlet air duct to the edge of the lip on the terminal mesh is 12mm (½in) more than the wall thickness. **THE FOUR SCREWS SECURING THE TERMINAL MESH TO THE FLUE DUCT MUST BE ACCESSIBLE FROM OUTSIDE THE BUILDING.** Tape the joint between the flue terminal assembly and the air duct (Fig. 1).
7. Manoeuvre the boiler into position until the two spacer pipes behind the air inlet duct touch the wall (Fig. 1).
8. Check that the flue terminal protrudes through the wall as detailed in 6 and make good.
9. Connect the water flow and return pipes (see 'Boiler Connections').
10. Fit the outer case as described in 'outer case' items 1 to 5.
11. Connect the electrical supply (see 'Electrical Connections').
12. Complete the installation as outlined in 'Commissioning the Unit' items 1-17.
13. Complete the assembly of the outer case as described in 'outer case' items 6 & 7.

Boiler connections (Fig. 2)

The boilers have 5 water connections:

2 × Rp1 (1in BSP internal) return connections.

2 × Rp1 (1in BSP internal) flow connections.

1 × Rp¾ (¾in BSP internal) flow connection.

The 1 × Rp¾ (¾in BSP internal) flow connection is for use when the pump is fitted inside the outer case. For other installations this connection must be plugged.

THE WATER SPREADER MUST BE FITTED TO THE PUMPED RETURN CONNECTION ON ALL INSTALLATIONS. THE MARKS ON THE SPREADER MUST BE BETWEEN THE TWO MARKERS ON THE COMBUSTION CHAMBER (Fig. 3) CHECK THAT THE SPREADER HAS THREE LOCATION MARKS.

When installing the pipework ensure that:

- (i) Suitable union fittings are used at the first joint of all boiler connections.
- (ii) The pipework will run through the cutouts provided in the outer case (Fig. 4).
- (iii) Drain off points are provided as appropriate.
- (iv) Pipe sizes are suitable for the system design.

Pump (Fig. 5)

A suitable pump e.g. Grundfos Selectric 4 or SMC Commadore with ball type isolating valves and 22mm compression fittings may be fitted inside the outer case. The pump should be connected to the ¾ flow connection on the front of the heat exchanger using the following standard fittings.

- A—1 off—Elbow ¾ BSP male × ¾ BSP female
B—1 off—Conex straight connector ¾ BSP male × 22mm copper
C—3 off—22mm Yorkshire elbows
D—1 off—92mm long—22mm copper tube
E—1 off—100 mm long—22mm copper tube
F—1 off—145mm long—22mm copper tube
G—1 off—42mm long—22mm copper tube

The redundant flow connection(s) must be plugged.

Accuracy is important to avoid the pump and or pipework obstructing removal of the top panel of the combustion chamber, or fouling the top panel of the outer case.

THE PUMP MUST NOT BE FITTED INSIDE THE CASE WHEN THE OPTIONAL TOP PANEL IS USED.

Outer case (Fig. 6)

Assemble the outer case in the following manner:

1. Locate the RH side panel over the pegs at the RH side of the base and press downwards to secure. When fitting the panels if access is restricted the cutouts at the top of the back edge of the panels can be used to pass the case fixing brackets.
2. Secure the panel to the case fixing brackets with the two screws provided.*
3. Repeat 1 & 2 with the LH side panel.
4. Secure the hinges of the fascia panel to the two side panels using two of the four screws provided.
5. At this point the electrical connections to the fascia panel can be made and the appliance can be commissioned. (See 'Electrical Connections' and 'Commissioning the Appliance' 1-17).
6. Swing the fascia panel upwards and secure to the side panels using the two screws retained to the control fascia.
7. Hook the bottom edge of the front panel over the lugs on the case and swing the top edge back till the pegs at the top of the panel locate in the corresponding holes. Press to secure.

*When the optional extra top panel is being fitted then the RH and LH side panels are fixed only by the screws at the front of the panel as access to the top screws may be limited. The top panel is then slid back to the wall and secured to the side panels by the fascia securing screws in 6.

Gas connection (Fig. 2)

Adapt the gas supply 15mm (½in BSP) within the outer case making the gas connection to the service tap provided.

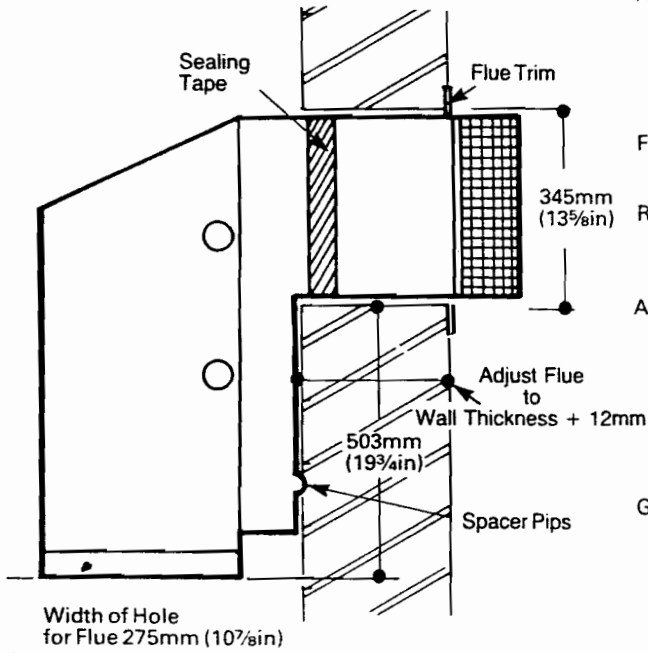

1. Flue Assembly

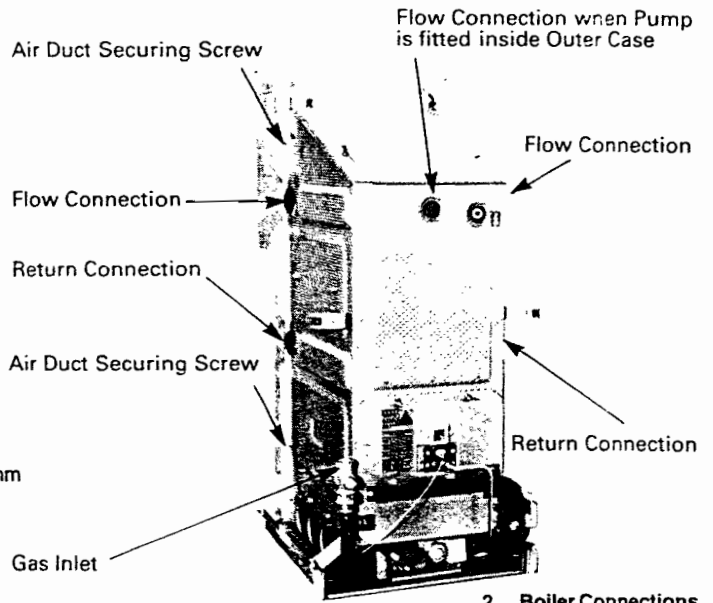

2. Boiler Connections

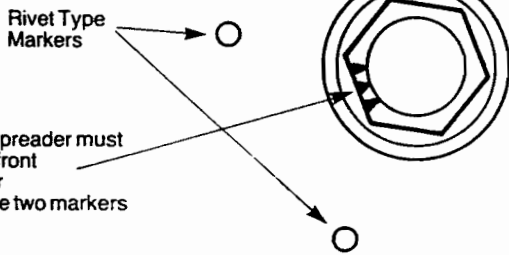

3. Spreader in Pumped Return Connection

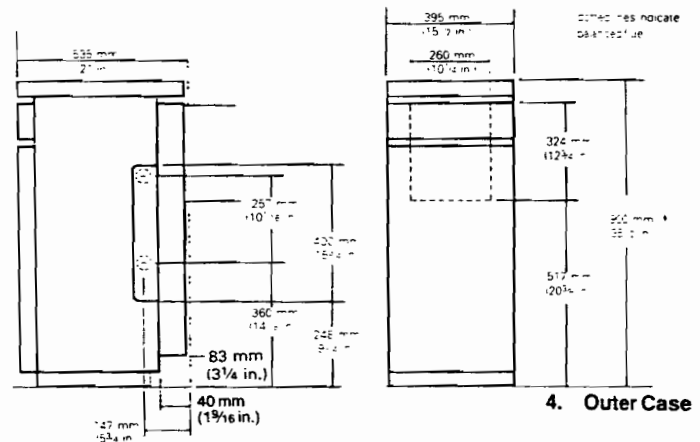

4. Outer Case

22mm. Compression 'Ball' Type Valves

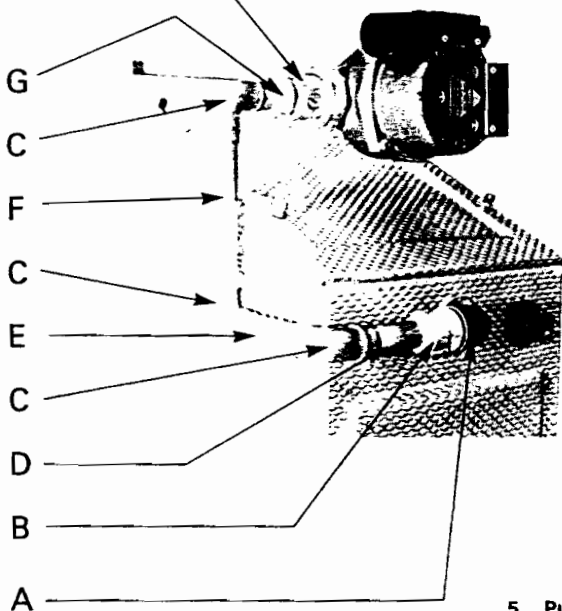

5. Pump in casing

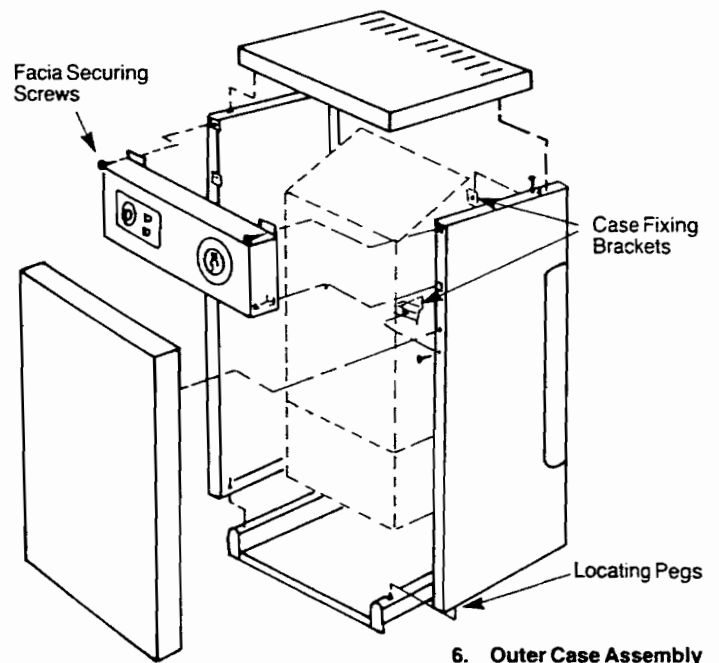

6. Outer Case Assembly

General

The mains supply required is 220/250 V 50 Hz fused at 3 amps. A double pole switch should be provided in the installation or an unswitched socket outlet should be used. All external wiring shall be correctly earthed and polarised and be in accordance with I.E.E. regulations.

Electrical supply to controls

The recommended cable for connection to the appliance is 0.5 sq. mm 16/.20 PVC heat resistant grade to BS 6500 1975.

The input cable should be secured with the cable clips provided and be laid to avoid contact with hot surfaces.

The length of the supply conductors between the cable grip and the terminals must be such that the current carrying conductors become taut before the earthing conductor if the cable should slip out of the cable grip.

1. With the outer case assembled as in 'outer case' 1-4 remove the 2 screws securing the thermostat cover to the fascia panel (Fig. 7).
2. Fit the input cable to the terminal strip and clamp using the cable grip provided and clamp the incoming cable into the cable clips provided on the outer case side panel so as to avoid contact with the hot combustion box surfaces.
3. Connect the 2 green and yellow earth wires halfway down the appliance wiring harness to the combustion chamber earth point on the outer case support bracket.
4. Fit the socket at the end of the wiring harness to the plug attached to the burner feed pipe and clip the wire to the cable clips provided.
5. Refit the thermostat cover to the fascia panel.
6. Push the thermostat phial into the thermostat pocket and clip the capillary behind the retaining clip (Fig. 8).

Programmer ('S' versions only)

This programmer is suitable for controlling all types of central heating and domestic hot water installations.

Data: Rated voltage 220/250V
Mains frequency 50Hz
Total rating 10A 250 VAC
Insulation — double insulated.

1. With the outer case assembled as in 'outer case' items 1-4 remove the 3 screws securing the programmer cover (Fig. 7).
2. Fit the wires to the terminal strip provided and to the boiler to suit the chosen control systems (see 'Control Systems') ensuring that the wires are fixed to the cable clamp provided and secured away from hot surfaces with the cable clips and straps provided.
3. Refit the programmer cover.

The programmer supplied is set to give ten programmes. If 16 programmes are required the programmer must be adjusted.

Ten position is suitable for gravity hot water and pumped central heating.

Sixteen position is suitable for gravity hot water with cylinder thermostat and motorised valve and pumped central heating: or hot water and central heating pumped with cylinder and room thermostats with a motorised valve in both circuits. To adjust for 16 programmes set the hot water programme selector to the ON position and the central heating programmer to the OFF position.

Turn the white programme range adjuster (Fig. 9) 90° anti-clockwise. To revert to ten programmes follow the same procedure but turn the white programme range adjuster 90° clockwise.

Line voltage is applied to terminals 3 & 4 when the programmer is in the ON position for hot water and central heating and to terminals 1 & 2 when it is in the OFF position.

Terminals 1.2.3.4.N.L. connect the controls for Domestic Hot Water and Central Heating applications shown in 'Control Systems'.

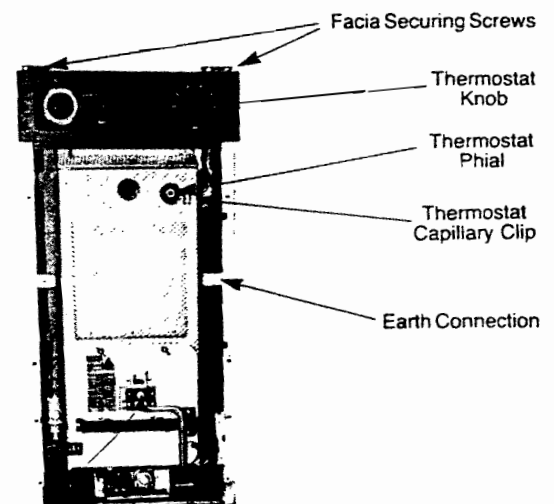
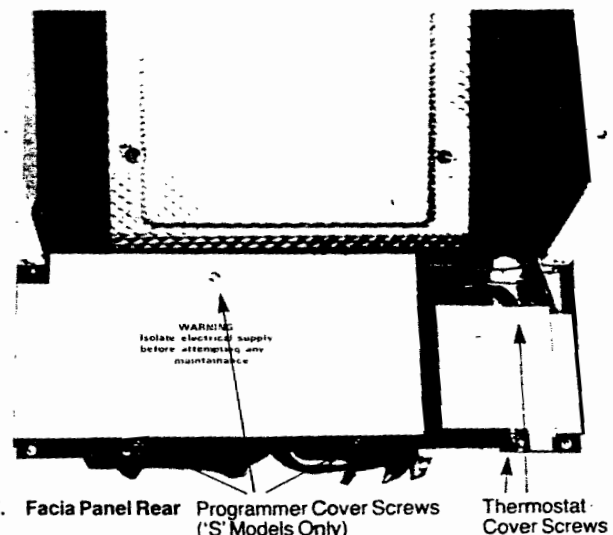

8. Boiler Thermostat



Programme range adjuster set for 10 programmes.



Programmer range adjuster set for 16 programmes.

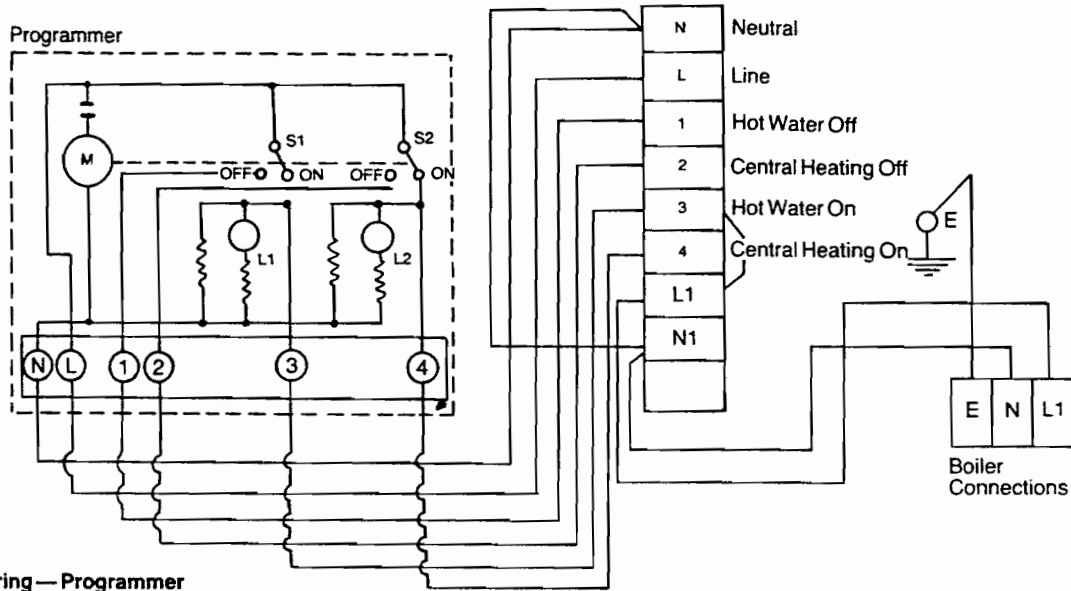

9. Internal Wiring — Programmer

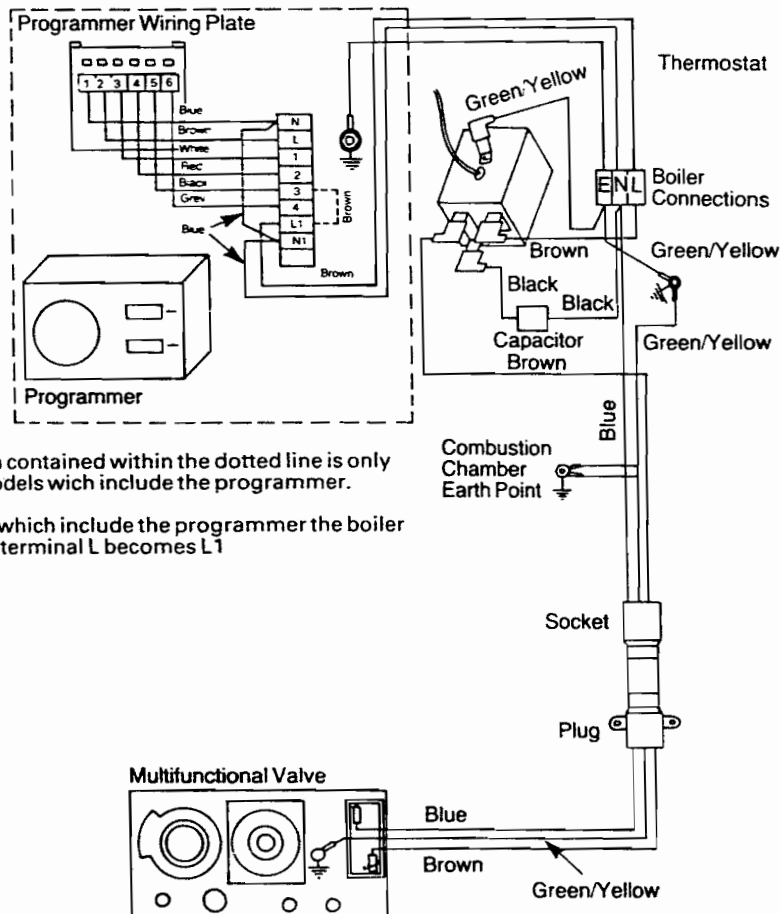

This section contained within the dotted line is only fitted on models which include the programmer.

On models which include the programmer the boiler connection terminal L becomes L1

10. Internal Wiring — Boiler

1. Pipe sizing

- (a) The sizes of flow and return pipes from the boiler should be determined by normal methods according to the requirements of the system. Normally the pump should be set to give a 11°C (20°F) drop across the system with the gas rate of the boiler adjusted to the output required.
- (b) The open vent pipe must be a minimum of 22mm and must rise continuously to above the feed tank. The flow pipe from the boiler may form part of the open vent. No part of the open vent should contain a valve.
- (c) The cold feed pipe, 15mm, should be connected to the return main as near as possible to the boiler and should not include a valve unless required by the local water authority.

Domestic Hot Water

An indirect cylinder must be used. If a self priming indirect type is employed it must be of adequate size and applied strictly in accordance with the cylinder manufacturers' instructions.

Fuel economy

Better fuel economy is achieved by exercising control of the boiler by means of a room thermostat and/or a cylinder thermostat as appropriate. Examples of different control systems are given below along with the appropriate wiring diagrams.

ALLOWING THE BOILER TO CYCLE ON THE BOILER THERMOSTAT DOES NOT PRODUCE THE BEST RESULTS. SIMILARLY FOR ECONOMY AND BOILER PERFORMANCE THE SYSTEM SHOULD BE DESIGNED SO THAT GRAVITY CIRCULATION IN THE HEATING CIRCUIT DOES NOT TAKE PLACE WHEN THE PUMP IS NOT RUNNING.

Control systems

Fully pumped systems

One Zone Valve (Fig. A)

Zone valve with auxiliary switch fitted at point V. A cylinder thermostat and a room thermostat are used to control both the pump and the boiler. The room thermostat also controls the zone valve to stop water circulation in the heating system.

Two Zone Valves (Fig. C)

Zone valves are fitted at points V and U to stop water circulation to the heating system and the cylinder. The valves are controlled by a room thermostat and a cylinder thermostat respectively, each of which also controls the boiler and the pump.

Diverter Valve (Fig. D)

A diverter valve is inserted at point W to direct water circulation to either the cylinder or the heating system. The valve along with the pump and the boiler is controlled by a cylinder thermostat and a room thermostat.

Gravity D.H.W. Systems

Sundial Control (Fig. B)

Both the boiler and the pump are controlled by a cylinder thermostat and a room thermostat. The room thermostat overrides the cylinder thermostat when heating is called for.

Fully Pumped System (Diagrammatic)

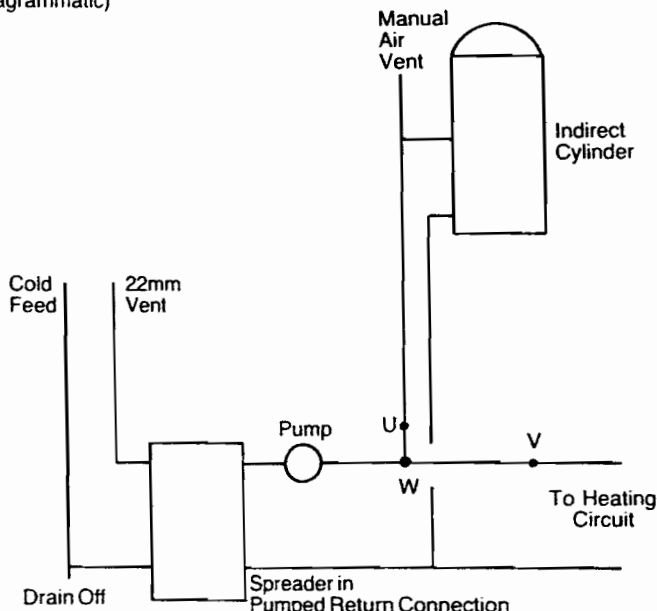

Gravity Domestic Hot Water (Diagrammatic)

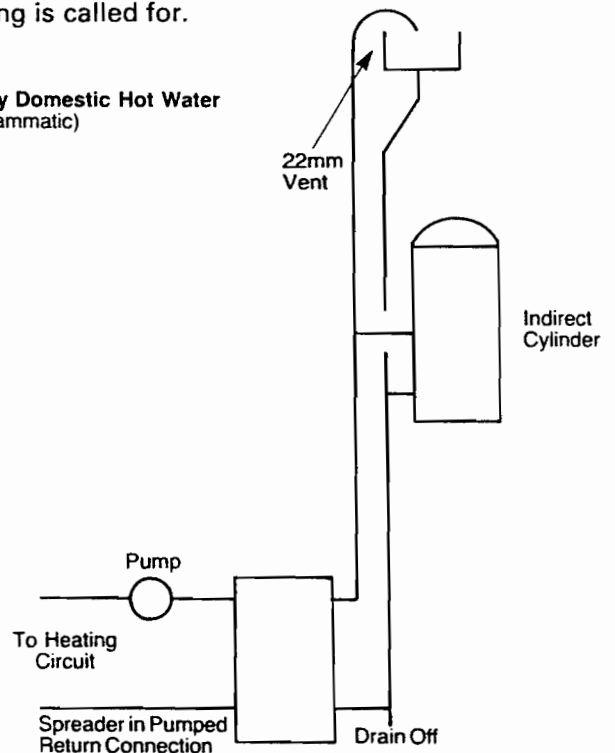

In both cases the Pump shown in the Flow Pipe to avoid Sub Atmospheric Pressure (Air Entrainment) in the system.



Programmer range adjuster set for 10 programmes.



Programmer range adjuster set for 16 programmes.

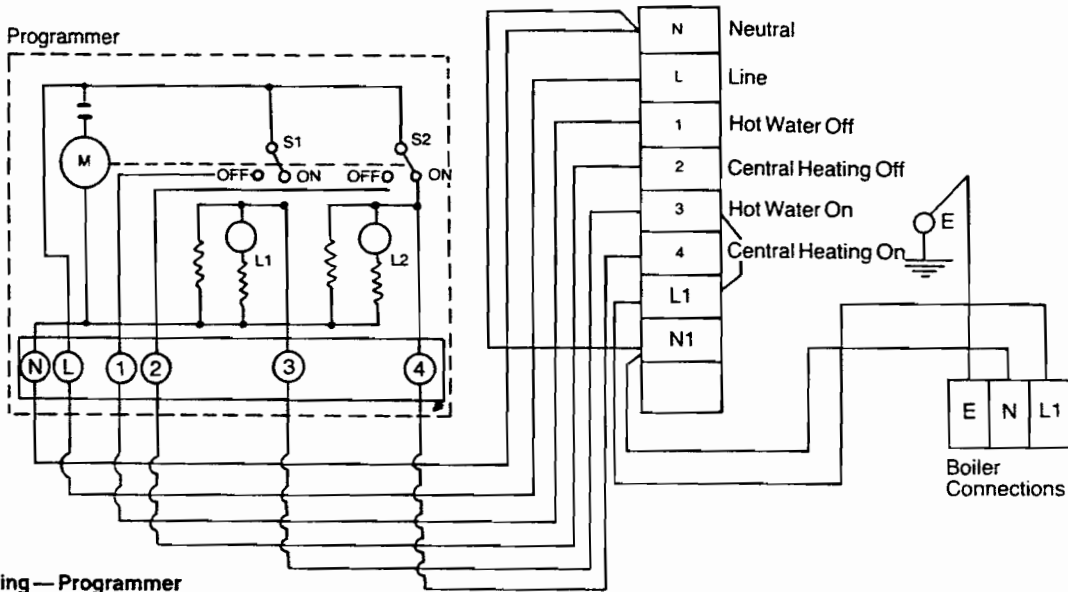

9. Internal Wiring — Programmer

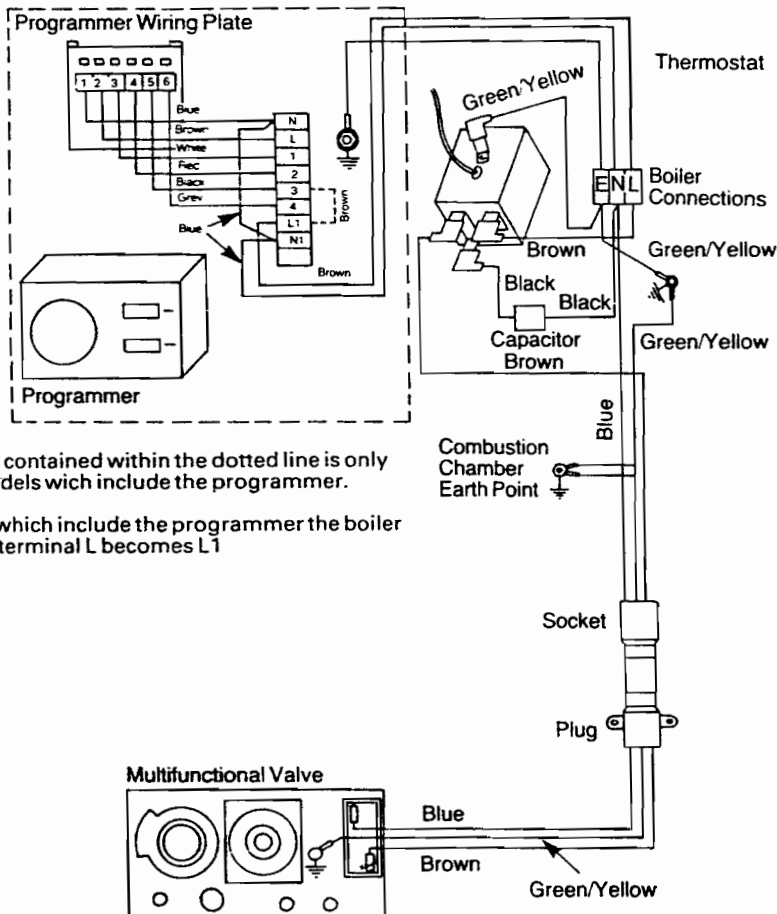

10. Internal Wiring — Boiler

1. Pipe sizing

- (a) The sizes of flow and return pipes from the boiler should be determined by normal methods according to the requirements of the system. Normally the pump should be set to give a 11°C (20°F) drop across the system with the gas rate of the boiler adjusted to the output required.
- (b) The open vent pipe must be a minimum of 22mm and must rise continuously to above the feed tank. The flow pipe from the boiler may form part of the open vent. No part of the open vent should contain a valve.
- (c) The cold feed pipe, 15mm, should be connected to the return main as near as possible to the boiler and should not include a valve unless required by the local water authority.

Domestic Hot Water

An indirect cylinder must be used. If a self priming indirect type is employed it must be of adequate size and applied strictly in accordance with the cylinder manufacturers' instructions.

Fuel economy

Better fuel economy is achieved by exercising control of the boiler by means of a room thermostat and/or a cylinder thermostat as appropriate. Examples of different control systems are given below along with the appropriate wiring diagrams.

ALLOWING THE BOILER TO CYCLE ON THE BOILER THERMOSTAT DOES NOT PRODUCE THE BEST RESULTS. SIMILARLY FOR ECONOMY AND BOILER PERFORMANCE THE SYSTEM SHOULD BE DESIGNED SO THAT GRAVITY CIRCULATION IN THE HEATING CIRCUIT DOES NOT TAKE PLACE WHEN THE PUMP IS NOT RUNNING.

Control systems

Fully pumped systems

One Zone Valve (Fig. A)

Zone valve with auxiliary switch fitted at point V. A cylinder thermostat and a room thermostat are used to control both the pump and the boiler. The room thermostat also controls the zone valve to stop water circulation in the heating system.

Two Zone Valves (Fig. C)

Zone valves are fitted at points V and U to stop water circulation to the heating system and the cylinder. The valves are controlled by a room thermostat and a cylinder thermostat respectively, each of which also controls the boiler and the pump.

Diverter Valve (Fig. D)

A diverter valve is inserted at point W to direct water circulation to either the cylinder or the heating system. The valve along with the pump and the boiler is controlled by a cylinder thermostat and a room thermostat.

Gravity D.H.W. Systems

Sundial Control (Fig. B)

Both the boiler and the pump are controlled by a cylinder thermostat and a room thermostat. The room thermostat overrides the cylinder thermostat when heating is called for.

Fully Pumped System
(Diagrammatic)

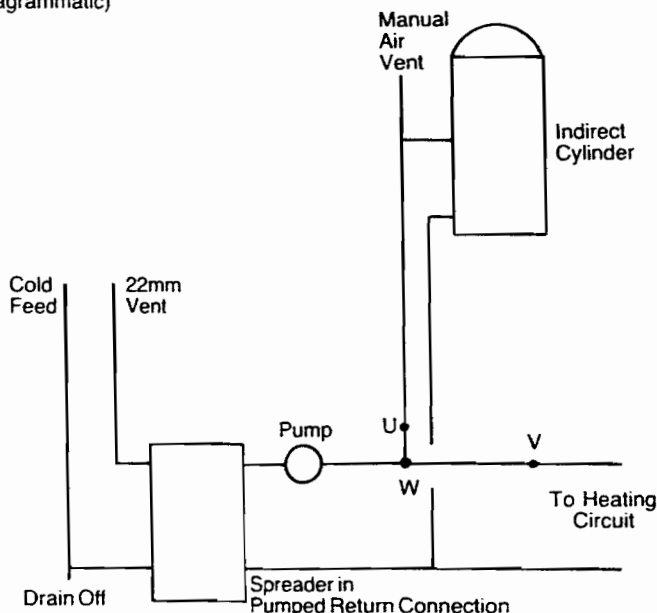

Gravity Domestic Hot Water
(Diagrammatic)

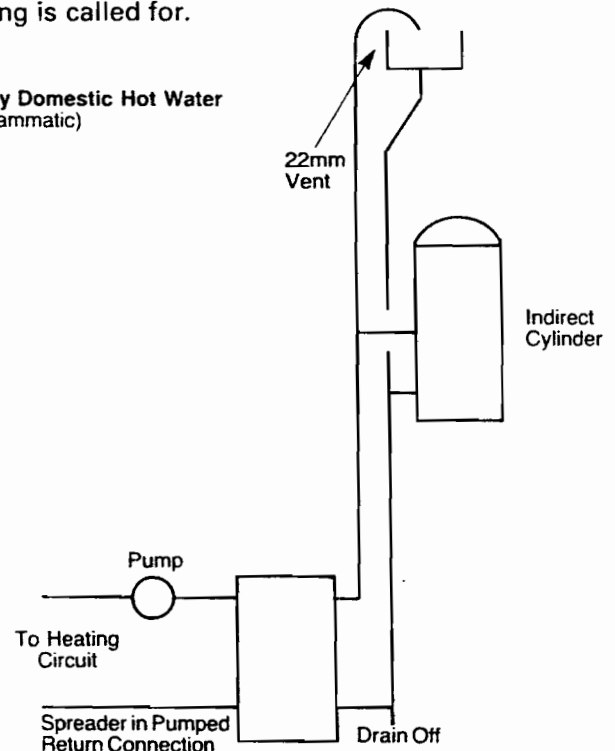

In both cases the Pump shown in the Flow Pipe to avoid Sub Atmospheric Pressure (Air Entrainment) in the system.

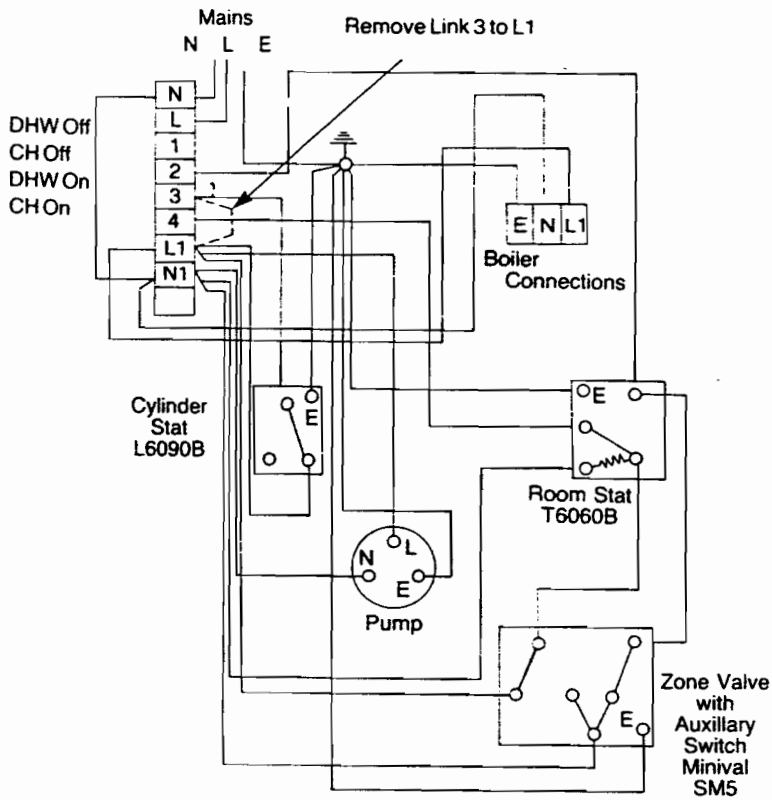

A - One Zone Valve - Fully Pumped System

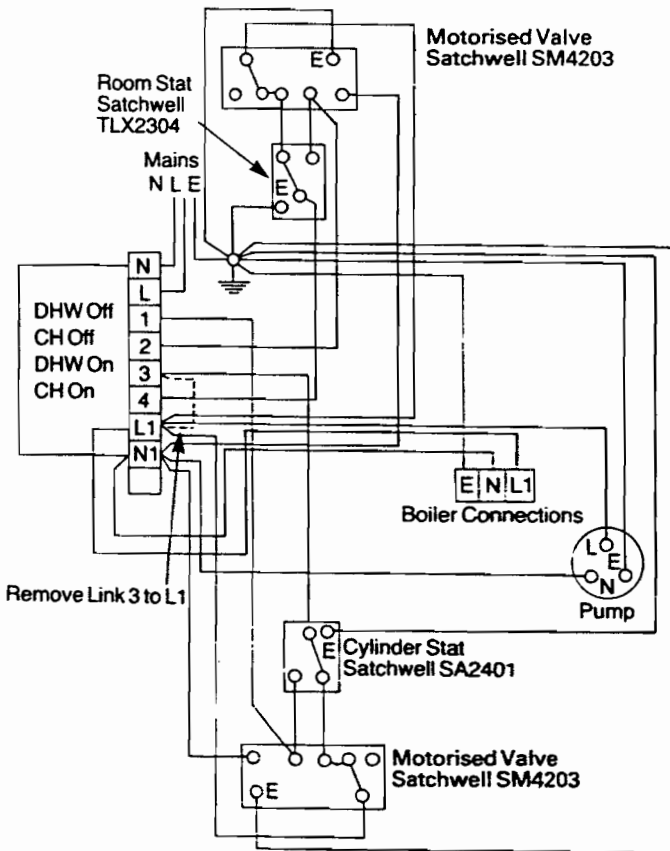

C - 2 Zones Valves - Fully Pumped System

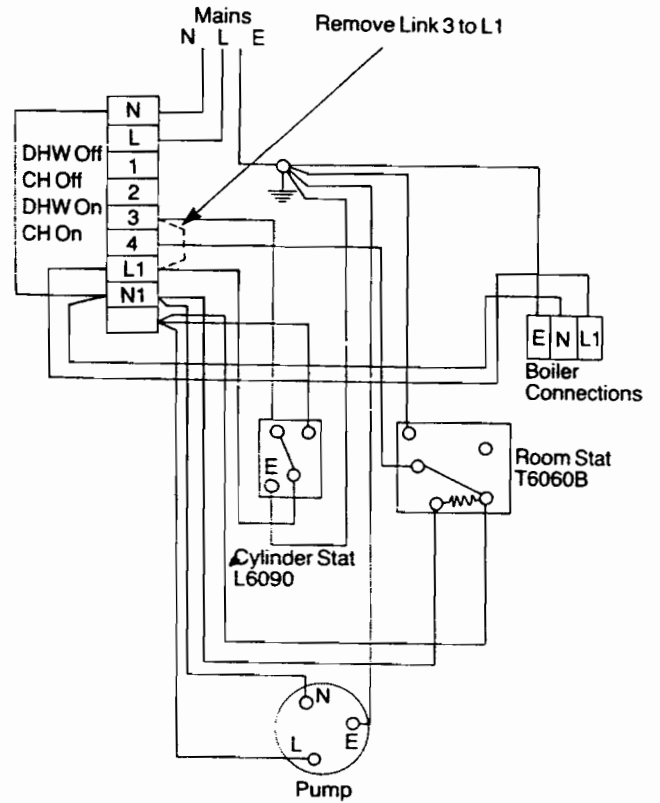

B - Sundial Gravity System

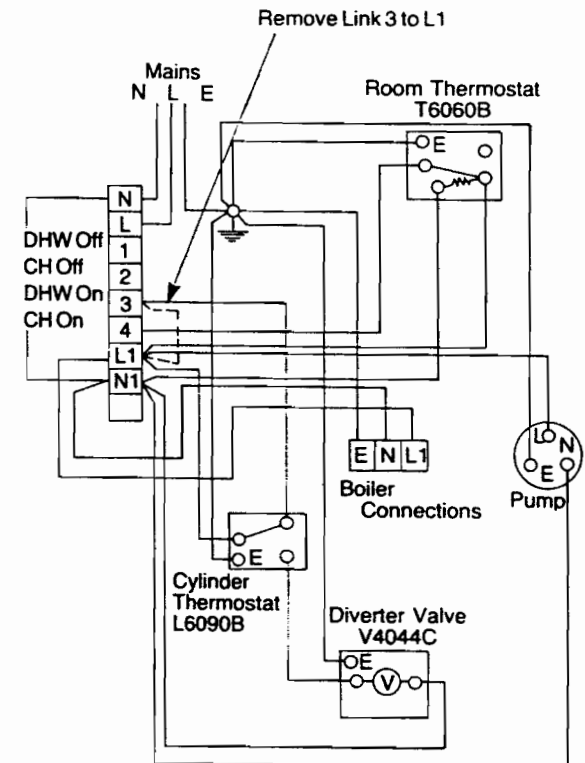

D - Diverter Valve - Fully Pumped System

1. Flush the whole system with all valves open.
2. Fill the system, vent the radiators and check for water leaks.
3. Turn the gas service tap to the 'on' position, check for gas soundness (CP 331:3).
4. Purge the air from the gas supply pipe at the gas service tap.
5. Turn the boiler thermostat to the 'off' position.
6. Turn on the mains electrical supply and ensure that all external controls e.g. room thermostat, timer, etc., are calling for heat.
7. Remove the burner pressure test point screw and connect a pressure gauge.
8. Hold in the grey 'on/off' button on the gas control valve (Fig. 11).
9. Press the igniter button (Fig. 11) and release. Repeat until pilot lights. Hold in grey 'on/off' button for a further 20 seconds and then release. The pilot light should then stay alight.
If the pilot fails to remain alight turn the grey 'on/off' button clockwise, wait 3 minutes and start again from 8. The flame should be without a yellow tip and be approximately 25mm (1in) long. No adjustment of the pilot flame is necessary as with the restrictor screw fully open the pilot jet is sized to give the correct flame length at 20 mbar (8in wg) inlet pressure.

10. Operate the burner by turning the thermostat knob to the high setting. CHECK THE OPERATION OF THE FLAME FAILURE DEVICE by turning the grey ON/OFF button clockwise. The burner and the pilot should go out.
11. Turn the boiler thermostat to the OFF position. Wait three minutes and re-light the pilot
12. Operate the burner by turning the thermostat knob to the high setting.
13. Remove the cover screw and adjust the appliance governor to give the correct pressure corresponding to the required input. See table below. Check this pressure after 10 minutes and adjust if necessary (Fig. 11). Replace cover screw.
14. Turn the boiler thermostat to the 'off' position and re-check the pilot flame length.
15. The system should now be flushed again whilst hot, refilled, vented and checked for water leaks.
16. Make a final check for gas soundness.
17. Replace the burner pressure test point screw and then turn the boiler thermostat to the required setting.
18. Complete the assembly of the outer case as described in 'outer case' item 7.
19. Instruct the user in the use of the unit.

NOTE: In the event of an electrical fault after the installation of the appliance, preliminary electrical system checks must be carried out (i.e. Earth continuity, polarity and resistance to earth).

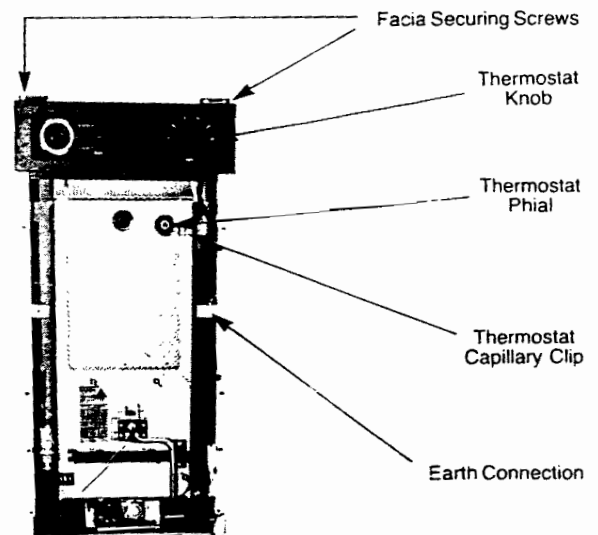
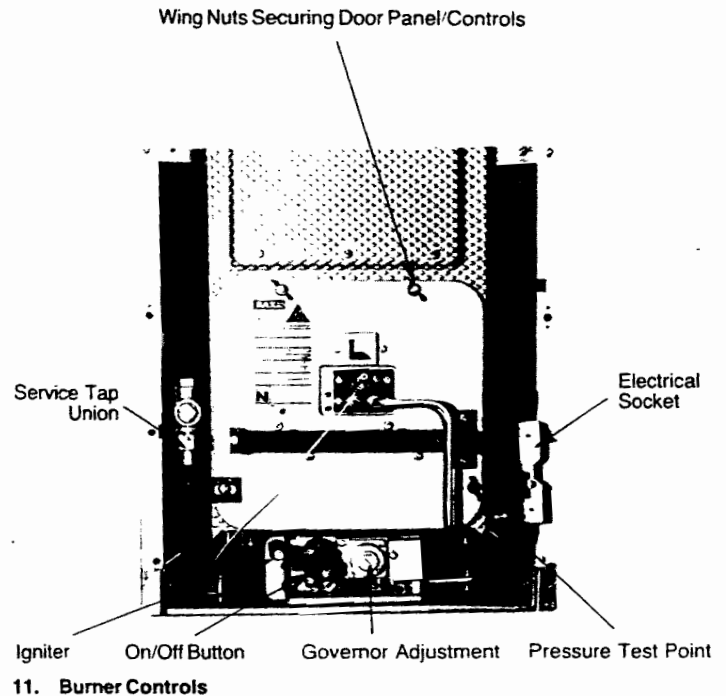

Model	Maximum Input	Setting Pressure	Minimum Input	Setting Pressure
FS 801 RS FS 801S RS	30 kW (102500 Btu/h)	16.3 mbar (6.5" w.g.)	27 kW (92500 Btu/h)	13.7 mbar (5.5" w.g.)
FS 701 RS FS 701S RS	26.5 kW (90300 Btu/h)	13.3 mbar (5.3" w.g.)	23.5 kW (80300 Btu/h)	10.5 mbar (4.2" w.g.)
FS 601 RS FS 601S RS	22.8 kW (77900 Btu/h)	13.4 mbar (5.4" w.g.)	19.6 kW (67100 Btu/h)	9.7 mbar (3.9" w.g.)

Baxi FS 801 RS
Baxi FS 801S RS
Baxi FS 701 RS
Baxi FS 701S RS
Baxi FS 601 RS
Baxi FS 601S RS
Exploded Diagrams

Outer Case

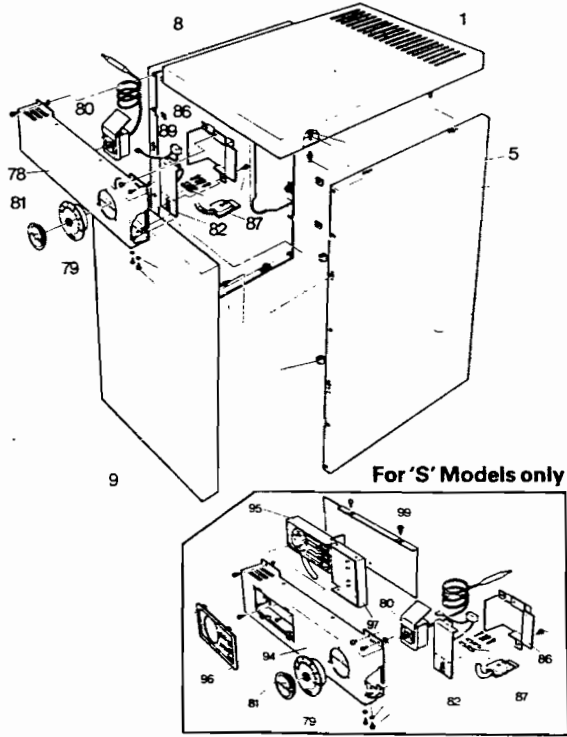

Key No 40 Boiler

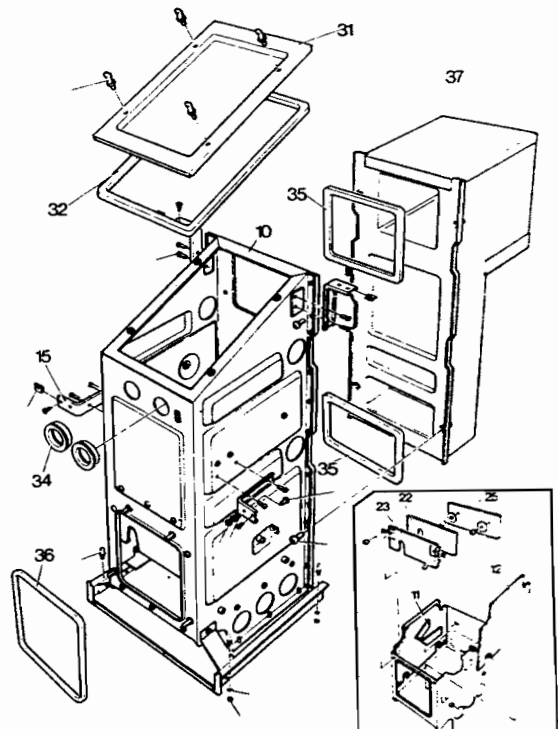
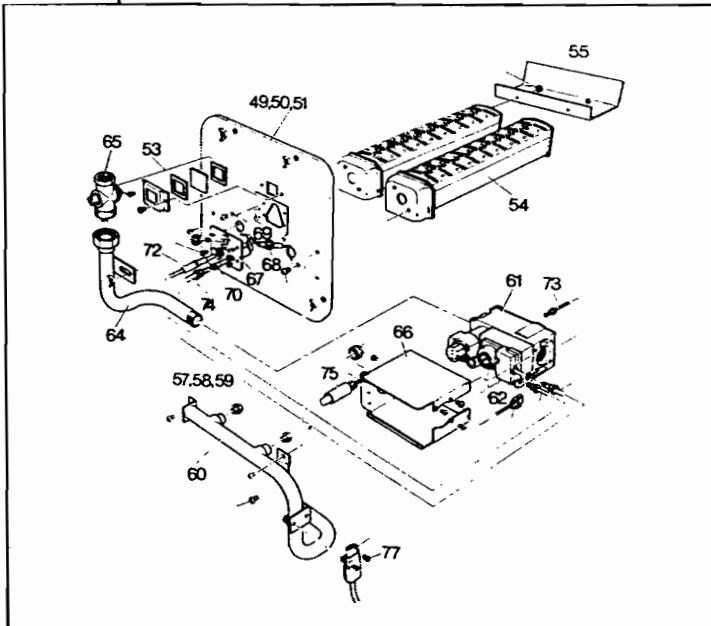
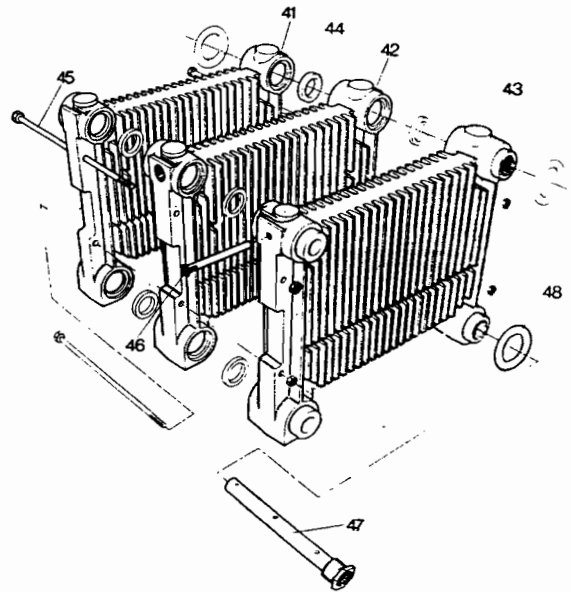

Servicing the Unit

(See 'BOILER SERVICING GUIDE' label on the boiler)

Items 1-27 are for maintenance to be carried out annually.

1. Turn off the electrical supply to the boiler.
2. Remove the front panel of the outer case by pulling forwards at the top and lifting upwards.
3. Remove the top panel of the outer case by pulling upwards.
4. Turn off the gas supply at the service tap and disconnect the union (Fig. 13).
5. Disconnect the electrical socket by pulling upwards (Fig. 13).
6. Remove the four wing nuts and carefully withdraw the burner and controls assembly (Fig. 13).
7. Release the two screws securing the front insulation assembly and remove the assembly (Fig. 14).
8. Remove the air scoop by pulling forwards from its retaining clip.
9. Remove the four thumbscrews securing the top inspection panel.
10. Remove any dirt that may have accumulated in the flue outlet duct.
11. Clean the heat exchanger with a bristle brush and brush out the bottom of the combustion box ensuring that the air opening at the rear is clear.
12. Check all the insulation panels for damage, replace if necessary. Refit the front insulation panel, the top inspection panel and the air scoop.
13. Clean the burner as follows:
 - (a) Remove the two nuts securing the air guide to the burners (Fig. 16).
 - (b) Remove the burners by removing the securing screws (2 per burner) (Fig. 17).
 - (c) Remove the split pin on each burner manifold (Fig. 16) and twist each burner in the direction shown (Fig. 16) to release the bayonet fitting and withdraw the venturi unit. Clear away any lint or deposits which may have accumulated inside the burners. Refit the venturi sections ensuring that the gaskets are not damaged. Refit the split pins.
 - (d) Remove the injectors from the inlet manifold, clean carefully and replace.
14. Clean the pilot as follows:

Unscrew the pilot tubing nuts at both ends and remove the pilot tube. Remove and clean the pilot injector and clean the pilot shroud (Fig. 17).
15. Re-assemble the pilot components and then the burners in reverse order of dismantling.
16. Refit the burner and controls assembly checking that the door seal is undamaged. Replace if necessary.
17. Reconnect the gas union at the service tap. Turn on the tap and check for gas soundness.
18. Refit the electrical socket and turn the thermostat to the OFF position.
19. Refit the outer case top panel.
20. Hold in the grey 'on/off' button on the gas control valve (Fig. 13).
21. Press in the igniter button and release. Repeat until the pilot lights. Hold in the grey 'on/off' button for a further 20 seconds and then release. The pilot should then stay alight. If the pilot fails to remain alight, turn the grey 'on/off' button fully clockwise and release. Wait 3 minutes and start again from 20. The flame should be without a yellow tip and be approximately 25mm (1in) long. No adjustment of the pilot flame is necessary as with the restrictor screw fully open the pilot jet is sized to give the correct flame length at 20 mbar (8in wg) inlet pressure.
22. Turn on the electricity supply to the boiler.
23. Remove the pressure test point screw (Fig. 13). Connect a pressure gauge and operate the burner by turning the thermostat knob to its highest setting.
24. Check that the pressure corresponding to the range rated output is correct for the installation (see data label). If necessary remove the cover screw and adjust the appliance governor (Fig. 13).
25. Turn the boiler thermostat to the 'OFF' position and refit the pressure test point screw.
26. Turn the boiler thermostat to its original setting.
27. Replace the outer case front panel.

Wing Nuts securing Burner and Controls Assembly

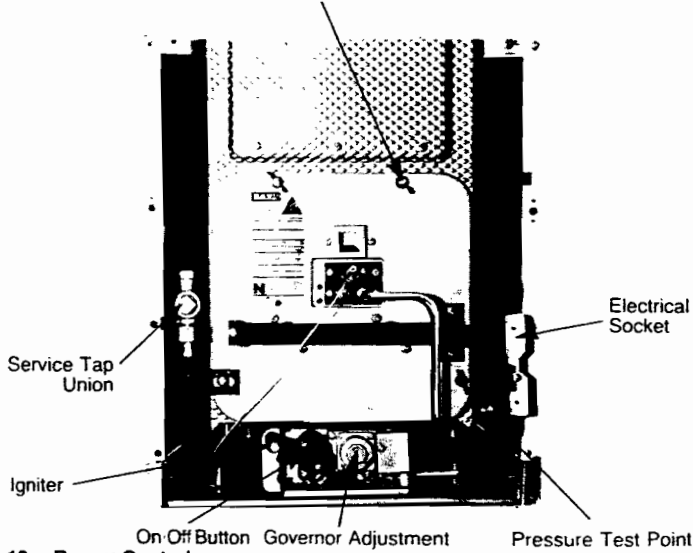

13. Burner Controls

Front Insulation Securing Screws

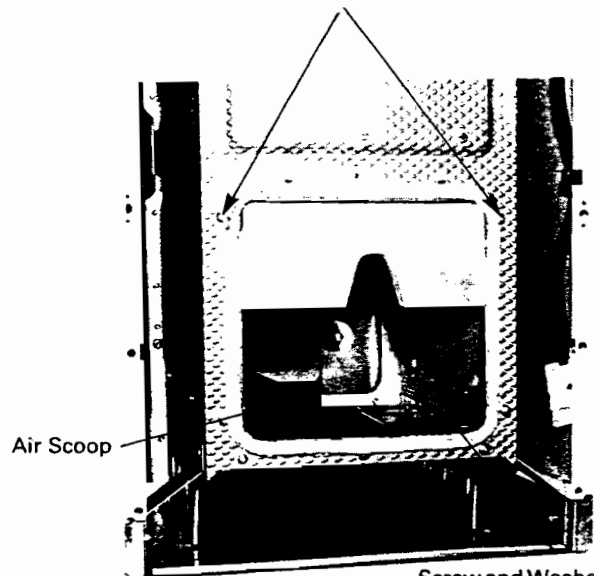

Screw and Washer securing Side Insulation

14. Insulation Combustion Box Door

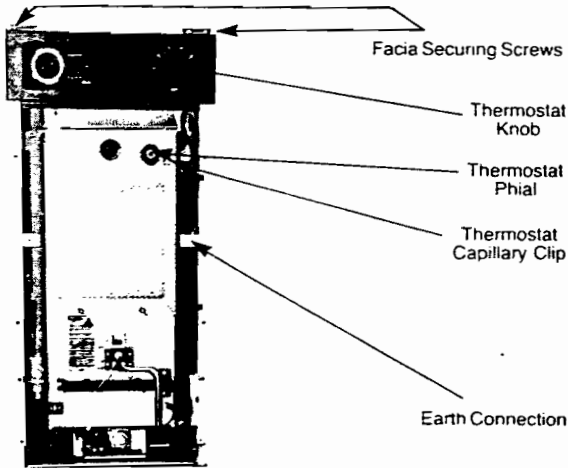

15. Boiler Thermostat

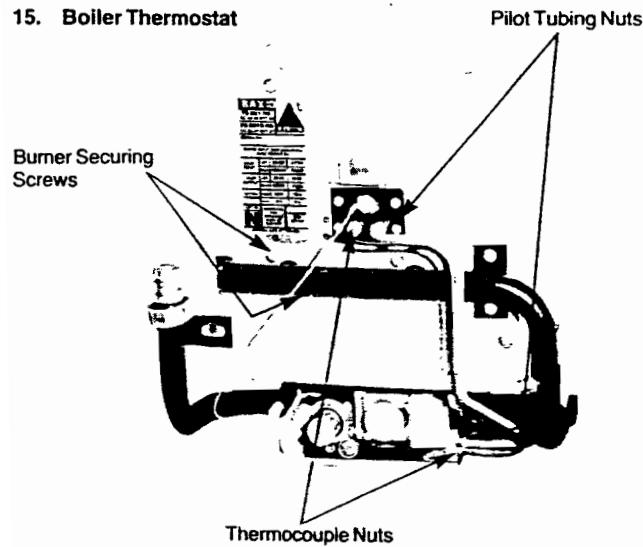

17. Burner and Controls Assembly

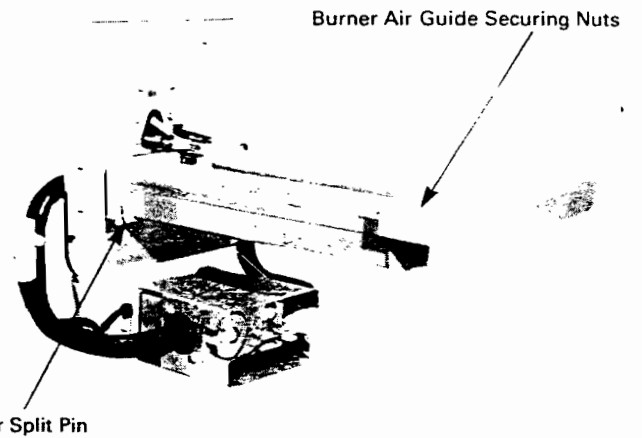

16. Burner and Controls Assembly (rear view)

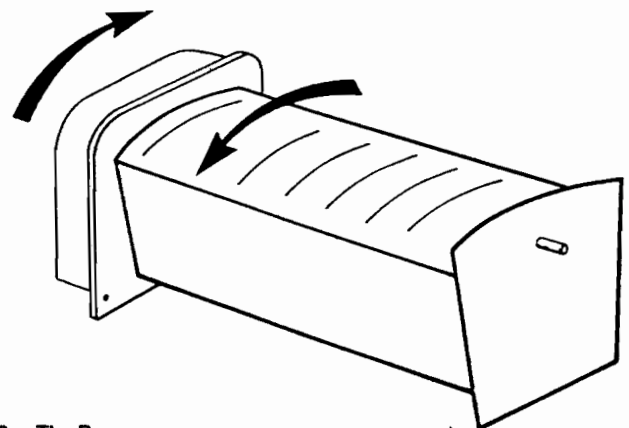

18. The Burner

Removal/exchange of individual components

Thermocouple

1. Turn off the electrical supply to the boiler.
2. Remove the outer case front panel by pulling forwards at the top and lifting upwards.
3. Turn off the gas supply at the service tap or at the grey 'on/off' button on the gas valve.
4. Release the thermocouple nut at the side of the gas valve (Fig. 19).
5. Release the thermocouple nut at the pilot bracket.
6. Re-assemble in reverse order of dismantling.

Thermocouple re-route device

1. Remove the burner and controls assembly as described in steps 1 to 6 "Servicing the Unit".
2. Release thermocouple nut at the valve.
3. Disconnect the re-route nut.
4. Remove terminal cover and re-route device.

Injectors

1. Remove the burner and controls assembly as described in steps 1 to 6 "Servicing the Unit".
2. Remove the two nuts securing the air guide to the burners and remove the guide (Fig. 20).
3. Remove the screws securing the burners to the door panel (two screws on each burner) (Fig. 19) and remove the burners.
4. Remove terminal cover and re-route device.

Burner

1. Remove the burner and controls assembly as described in steps 1 to 6 "Servicing the Unit".
2. Remove the two nuts securing the air guide to the burners and remove the guide (Fig. 20).
3. Remove the screws securing the burners to the door panel (two screws on each burner) (Fig. 19) and remove the burners.
4. Re-assemble in reverse order of dismantling.

Boiler thermostat

1. Isolate the electrical supply to the boiler.
2. Remove the outer case front panel by pulling forwards at the top and lifting upwards.
3. Remove the outer case top panel by pulling upwards.
4. Remove the two fascia retaining screws (Fig. 21) taking care not to lose the two spacer washers and allow the fascia to swing forwards on its hinges.
5. Release the thermostat capillary from behind its retaining clip and remove the thermostat phial from the boiler (Fig. 21).
6. Remove the screw securing the thermostat cover to the fascia (Fig. 22).
7. Disconnect the four spade electrical terminals from the thermostat.
8. Pull off the thermostat knob and remove the locknut securing the thermostat to the fascia panel.
9. Re-assemble in reverse order of dismantling ensuring that the thermostat phial is replaced into the thermostat pocket.

Programmer ('S' versions only) (Fig. 23)

1. Allow the fascia to swing forwards as described in items 1-4 of 'Boiler Thermostat removal'.
2. Slacken the two screws securing the wiring block to the programmer by swinging the fascia upwards and approaching the screws from below. Pull the wiring block away from the programmer.

3. Straighten the 4 tabs holding the programmer front cover to the fascia panel and remove the panel.
4. Remove the two screws securing the programmer to the fascia panel and remove the programmer.
5. Re-assemble in reverse order of dismantling.

Honeywell Gas Valve (Fig. 19)

1. Remove the burner and controls assembly as described in steps 1 to 6 "Servicing the Unit".
2. Disconnect the thermocouple nuts at the valve and at the pilot bracket.
3. Disconnect the pilot feed pipe at the valve and at the pilot bracket ensuring that the pilot injector is not misplaced.
4. Disconnect the electrode lead and remove the igniter.
5. Remove the screw securing the electrical terminal cover to the gas valve. Disconnect the electrical connections.
6. Remove the valve complete with the heat shield and inlet pipe by disconnecting the flanged injector manifold.
7. Disconnect the flanged inlet pipe. Retain the O rings for reassembly but replace if damaged.
8. Remove the heat shield by undoing the retaining screw.
9. Release the thermocouple re-route nut and remove the re-route.
10. Individual sub components of the valve may be replaced as outlined by Honeywell instructions.
11. Re-assemble in reverse order of dismantling.

Insulation in Combustion Box

1. Remove the burner and controls assembly as described in steps 1 to 6 "Servicing the Unit".
2. Release the two screws securing the front insulation assembly and remove the assembly (Fig. 24).
3. Remove the two screws and washers securing the two side insulation panels (Fig. 24) and carefully remove the panels diagonally through the door opening.
4. Remove the two screws and washers securing the back panel insulation.
5. Remove the ceramic insulation pad from the front insulation assembly by bending the securing tabs.
6. Replace insulation as necessary and bend down securing tabs where applicable.
7. Re-assemble in reverse order of dismantling, taking care not to damage the new insulation.

Piezo Igniter

1. Remove the burner and controls assembly as described in steps 1 to 6 "Servicing the Unit".
2. Disconnect the electrode lead at the igniter.
3. Remove the nut securing the igniter to the heat shield and remove the igniter.
4. Re-assemble in reverse order of dismantling.

Spark Electrode

1. Remove the burner and controls assembly as described in steps 1 to 6 "Servicing the Unit".
2. Disconnect the electrode lead at the electrode.
3. Remove the nut securing the electrode and remove the electrode.
4. Re-assemble in reverse order of dismantling.

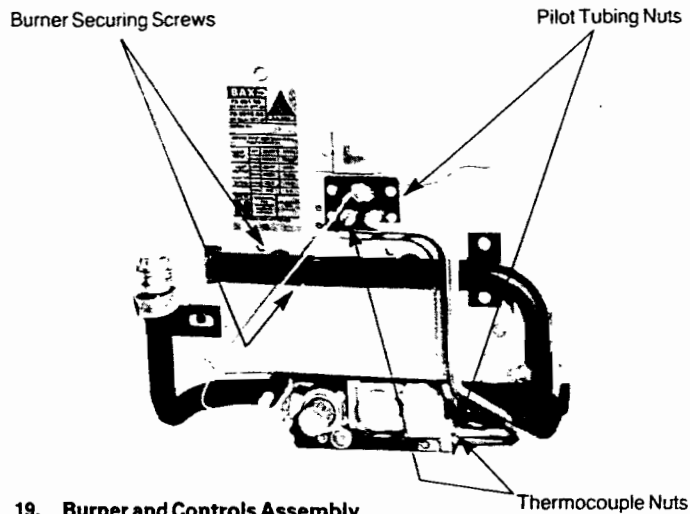

19. Burner and Controls Assembly

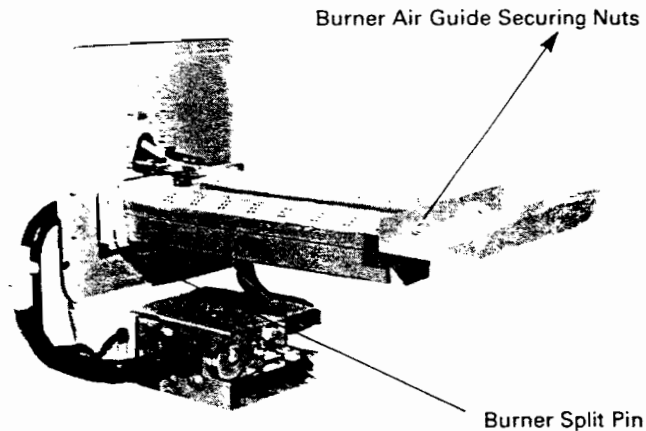

20. Burner and Controls Assembly (rear view)

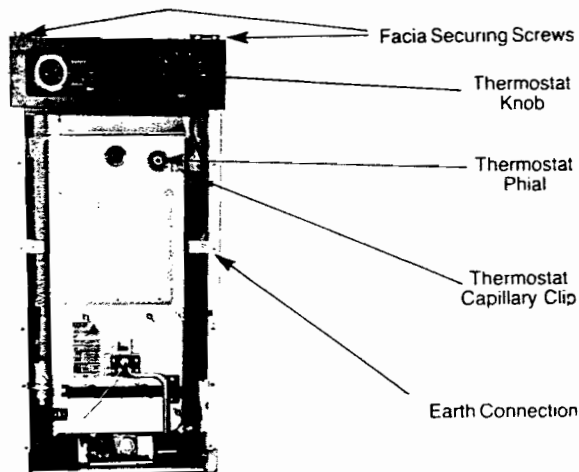

21. Boiler Thermostat

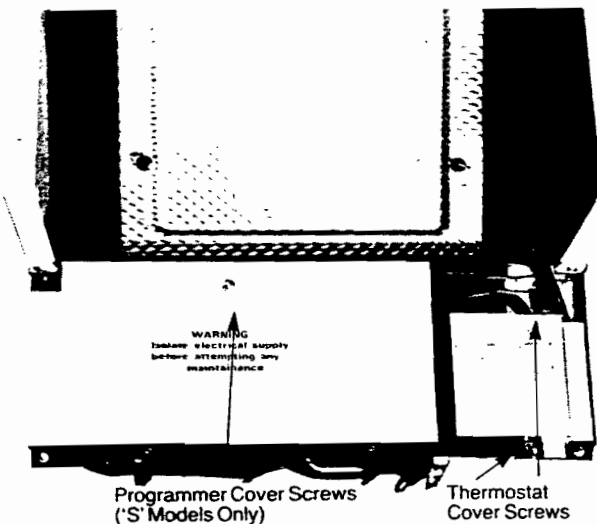

22. Facia Panel Rear

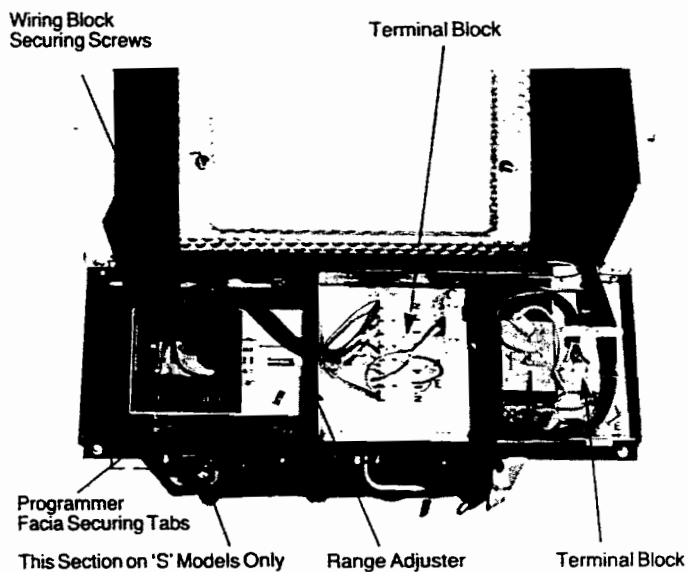

23. Electrical Connections

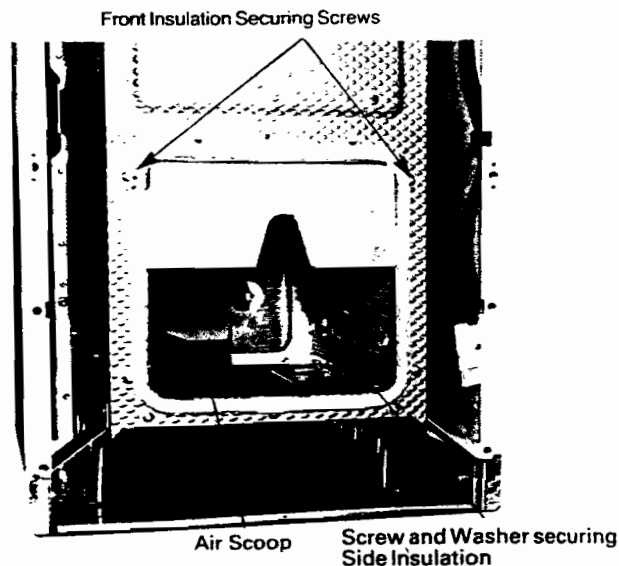

24. Combustion Box

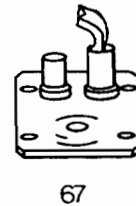
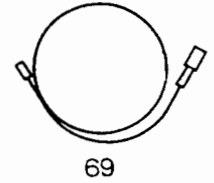
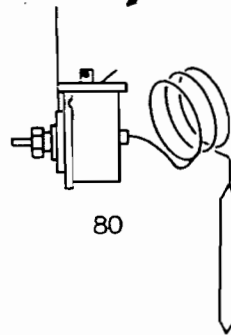
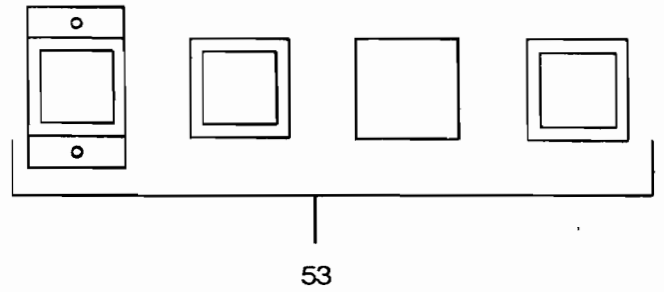
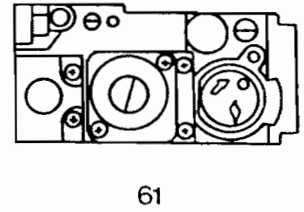
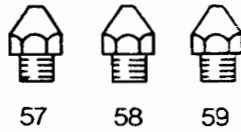
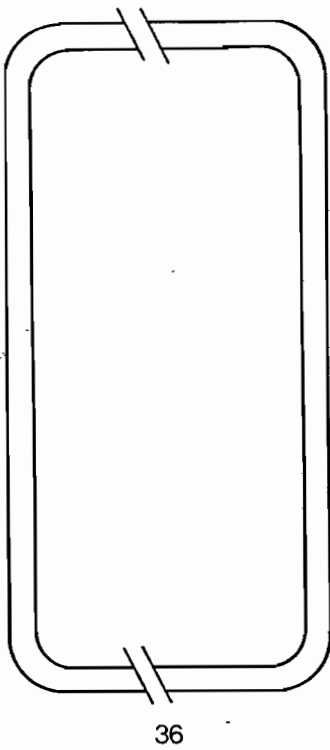

SHORT PARTS LIST

Baxi FS 801/701/601 RS Cat. 1 Nat. Gas
BG Appliance Numbers 41 077 30/29/28

Key	B.G. No.	Description	Manufacturers Part No.
36	364 260	Seal — Panel Door	112057
53	364 143	Kit — Sight Window	100134
54	383 509	Burner — Boiler — Aeromatic	112012
57	364 275	Injector — Stereomatic — 2.9mm — FS 801	112013
58	364 276	Injector — Stereomatic — 2.8mm — FS 701	112022
59	364 199	Injector — Stereomatic 2.7mm — FS 601	102147
61	393 180	Valve — Control — Multifunctional — Honeywell V4600C	062623
67	391 707	Burner — Pilot — Honeywell Q359A 1058	082211
68	387 852	Electrode — pilot ignition Kigass E3356	102024
69	183 628	Lead — Electrode	042740
70	364 282	Injector — Pilot — Honeywell — 0.38/0.35A	112011
72	390 131	Thermocouple — 18in Honeywell Q3909 A	102005
75	183 936	Kit — Piezo Igniter	040456
80	382 387	Thermostat — Ranco — P1004	112025
81	364 287	Knob Thermostat	112026

