



206496/8/87

Glow-worm

Installation and Servicing Instructions

To be left adjacent to the gas meter

SPACE SAVER 60B MKII

Balanced Flue Boiler

with Honeywell control

G.C. Number 41 313 02

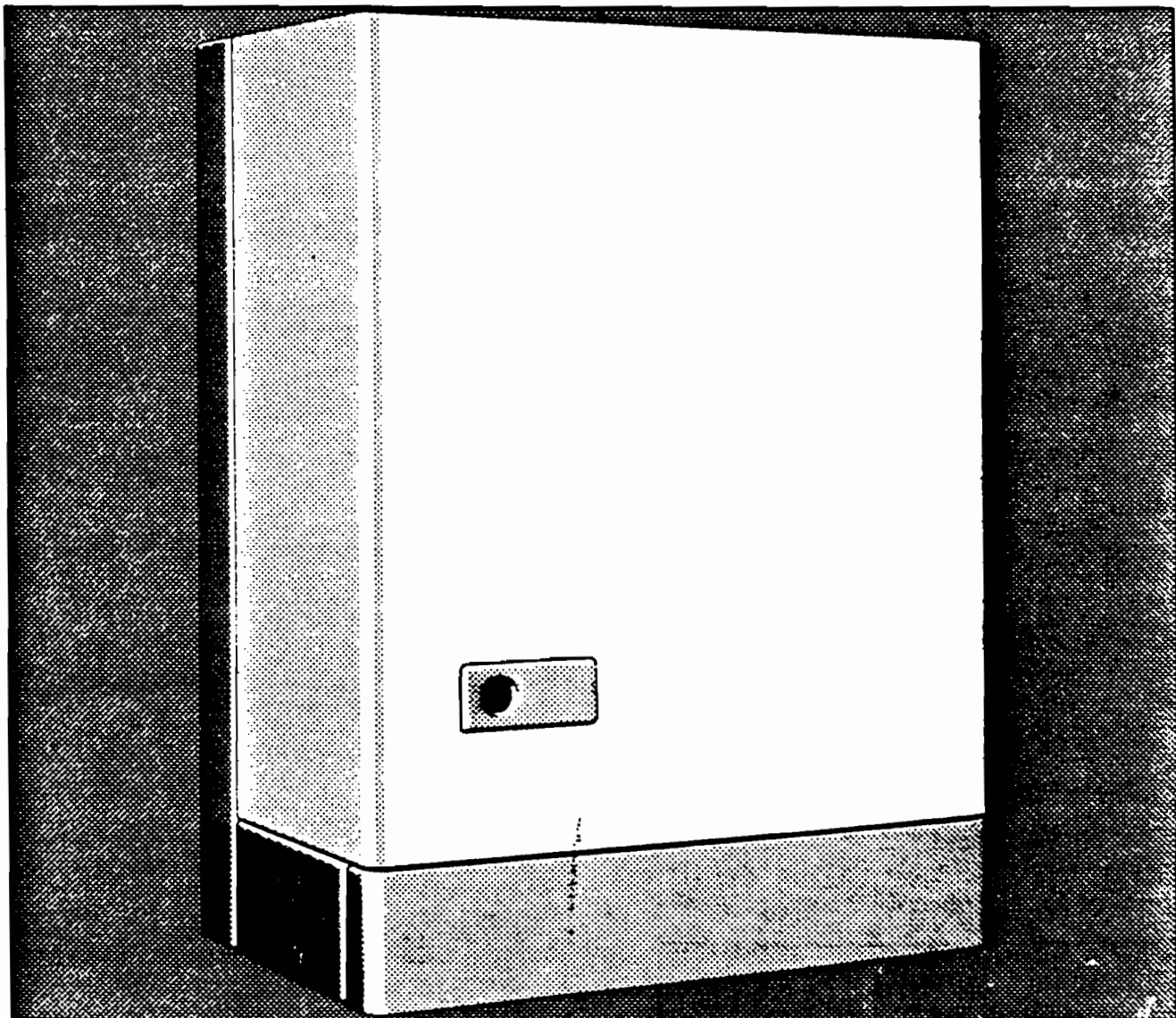

1 GENERAL

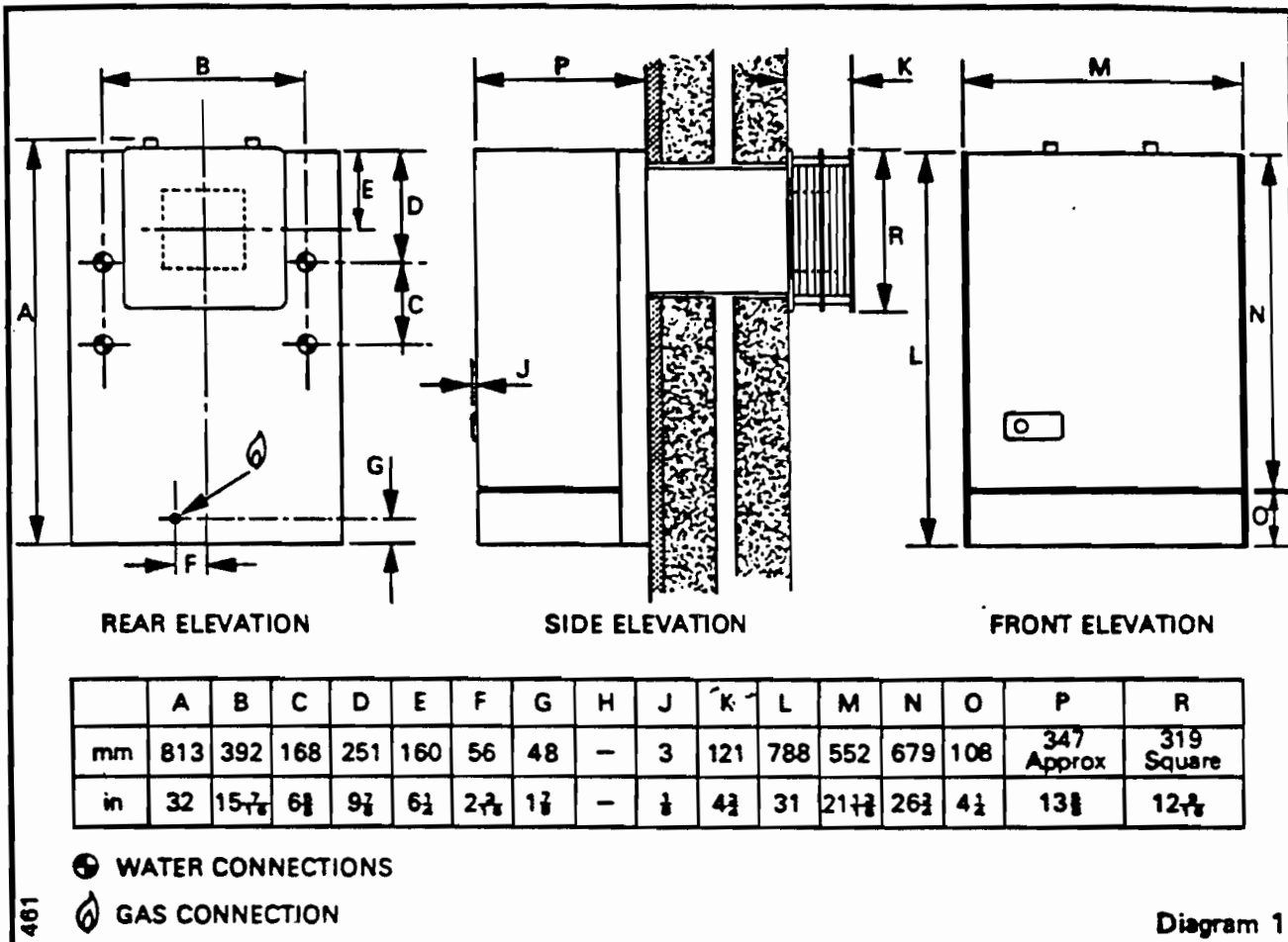

IMPORTANT NOTICE: The Space Saver 60B MkII is for use on natural gas only and MUST NOT be used on any other gas.

Weight of complete boiler: 76kg (168 lb)
 Water content: 7.5 litre (1.65 gal)
 Gas connection: Rc $\frac{1}{2}$
 Water connection: Rc1
 Injector: 3.70mm dia. hole
 Electrical supply: 240V ~, 50Hz fused 3A
 Burner: Aeromatic type 7/5 2008.

THIS BOILER IS RANGE RATED AND MAY BE ADJUSTED TO SUIT INDIVIDUAL SYSTEMS. THE FOLLOWING TABLE GIVES THE MAXIMUM AND MINIMUM OUTPUTS.

The boiler input as supplied is pre-set to the maximum heat input and should be adjusted to suit the system requirements.

RANGE RATING		min	max
NOMINAL HEAT INPUT	kw (Btu/h)	17.35 (59,200)	22.54 (76,900)
NOMINAL HEAT OUTPUT	kw (Btu/h)	13.19 (45,000)	17.59 (60,000)
BURNER SETTING PRESSURE (HOT)	mbar (in. w.g.)	9.1 (3.7)	16.1 (6.5)

When installing or servicing this boiler, care should be taken with the edges of sheet metal parts when handling, to avoid any possibility of injury.

It is essential that the boiler is installed strictly in accordance with the instructions in this booklet and the attention of the installer is drawn in particular to the following points.

1.1 STATUTORY REQUIREMENTS

THE INSTALLATION OF THIS BOILER MUST BE CARRIED OUT BY A COMPETENT PERSON AND MUST BE IN ACCORDANCE WITH THE RELEVANT REQUIREMENTS OF THE CURRENT ISSUE OF THE:

GAS SAFETY (Installation & Use) REGULATIONS, BUILDING REGULATIONS, I.E.E. WIRING REGULATIONS, BYELAWS OF THE LOCAL WATER UNDERTAKING AND BUILDING STANDARDS (Scotland) REGULATIONS.

DETAILED RECOMMENDATIONS ARE CONTAINED IN THE FOLLOWING BRITISH STANDARD CODES OF PRACTICE: CP331 PART 3, BS5440 PART 1, BS5440 PART 2, BS6798, BS5449 PART 1 and BS5546.

1.2 GAS SUPPLY

Installation pipes should be fitted in accordance with the current issue of CP331 Part 3. Pipework from the meter to the boiler must be of adequate size. Pipes of a smaller size than the boiler inlet gas connection should not be used. The complete installation must be tested for soundness as described in the above code.

1.3 ELECTRICAL

All electrical wiring must be carried out by a qualified electrician. All external components shall be of the approved type and shall be wired in accordance with the current issue of the I.E.E. Wiring Regulations and any local regulations which apply. The boiler must be earthed and connections to the mains supply should preferably be through an unswitched shuttered socket outlet and 3 amp fused 3 pin plug. Alternatively, a 3 amp fused double pole isolating switch or 3 amp fused spur box may be used serving only the boiler. Heat resistant flexible cable of at least 0.75mm^2 , (24/0.20mm), to BS6500 table 12 must be used to connect to the boiler controls drawer.

1.4 BOILER LOCATION

The boiler position should be such that the following minimum clearances are provided, (shown in diagram 3).

Right and left hand side of boiler - 6mm ($1/4$ in)
 Top of boiler casing - 108mm ($4\ 1/4$ in)
 Below boiler - 100mm (4 in)
 Front clearance - 330mm (13in).
 (From a permanent surface).

The boiler may be installed in any room, although particular attention is drawn to the requirements of the current issue of the I.E.E. Wiring Regulations with respect to the installation of the boiler in a room containing a bath or shower. Any electrical switch or boiler control utilising mains electricity should be so situated that it cannot be touched by a person using the bath or shower. The electrical provisions of the Building Standards (Scotland) Regulations are applicable to such installations in Scotland.

Where the installation of the boiler will be in an unusual location, special procedures may be necessary and BS6798 gives detailed guidance on this aspect.

A compartment used to enclose the boiler must be designed and constructed specifically for this purpose. An existing cupboard or compartment may be used providing that it is modified for the purpose. Details of the essential features of cupboards/compartment design are given in BS6798.

2.1 SYSTEM

This boiler shall only be connected to a cistern water supply which incorporates an open vent. The water head must not exceed 27 metres, (90 feet), or be less than 1 metre, (3ft 3in.).

For all systems supplying domestic hot water the cylinder must be indirect.

The boiler MUST NOT be connected to a sealed system.

2.2 GRAVITY HOT WATER CIRCULATION

It is recommended that a cylinder thermostat is used to prevent the stored water temperature becoming unnecessarily high when the central heating pump is off.

The domestic flow and return pipes must be 28mm. diameter. The installation must comply with the requirements of BS5446.

If the above conditions cannot be accommodated, it is suggested that a fully pumped system is employed.

2.3 FULLY PUMPED CIRCULATION

Where a single flow and return circuit is taken from the boiler, a minimum static head of 1 metre (3ft 3in) must be provided between the bottom of the cold feed tank and centre of waterway.

2.4 PUMP

Normally the pump should be set to give a temperature difference of 11°C , (20°F), across the system. At the appropriate pumped flow rate the resistance through the boiler can be found from the pressure loss graph.

2.5 SAFETY VALVE

The provision of a safety valve is not necessary for an open vented system, however if a safety valve is provided it must conform with the requirements of BS6759 Part 1 and be fitted to the requirements of BS6798.

2.6 DRAINAGE

A drain cock must be provided at the lowest point(s) of the system which will allow the entire system, boiler and hot water cylinder to be drained for maintenance purposes. Drain cocks shall be to BS2879, type 1.

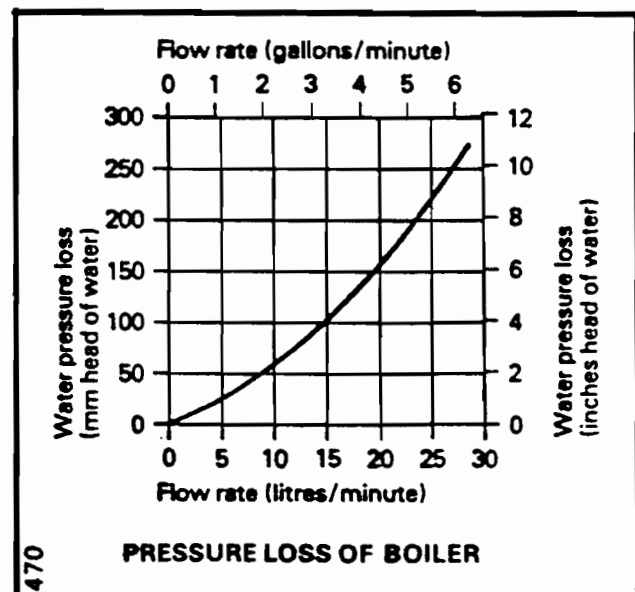

3 FLUEING AND VENTILATION

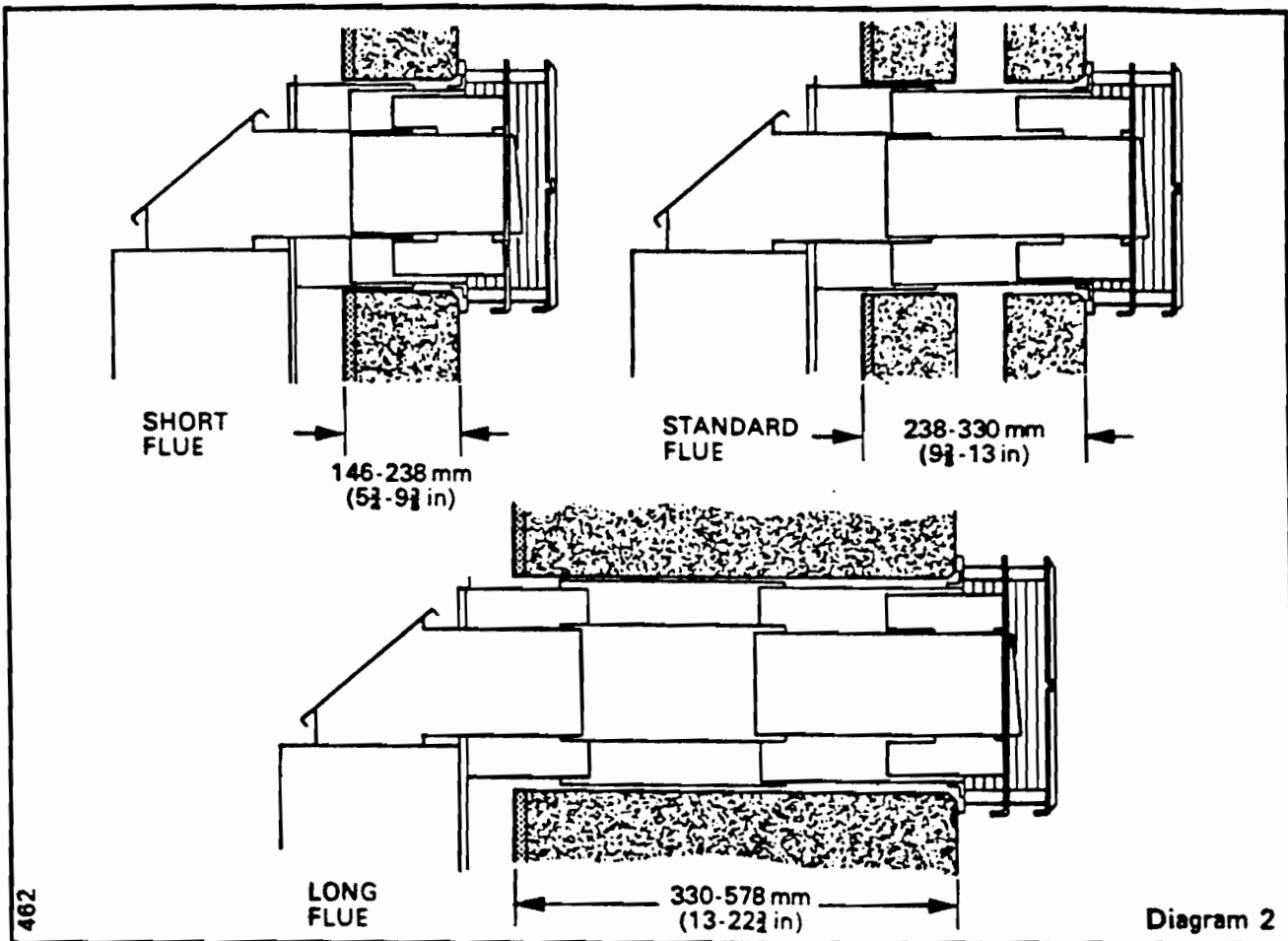

TERMINAL POSITION	MINIMUM SPACING	
	mm	(in)
1 DIRECTLY BELOW AN OPENABLE WINDOW, AIR VENT, OR ANY OTHER VENTILATION OPENING	300	(12)
2 BELOW GUTTERING	300	(12)
3 BELOW A BALCONY	600	(24)
4 BELOW EAVES	300	(12)
5 ABOVE ADJACENT GROUND OR BALCONY LEVEL	300	(12)
6 FROM DRAIN PIPES AND SOIL PIPES	75	(3)
7 FROM INTERNAL OR EXTERNAL CORNERS	600	(24)
8 FROM A SURFACE FACING A TERMINAL	600	(24)
9 FROM A TERMINAL FACING A TERMINAL	600	(24)

POSITION OF AIR VENTS	AIR FROM ROOM		AIR DIRECT FROM OUTSIDE	
	PER kW INPUT	(PER 5,000 Btu/h INPUT)	PER kW INPUT	(PER 5,000 Btu/h INPUT)
HIGH AND LOW LEVEL	8.0 cm ²	(2 in ²)	4.5 cm ²	(1 in ²)

191

3.1 BALANCED FLUE UNIT

3.1.1 Detailed recommendations for flueing are given in BS5440 Part 1. The following notes are intended to give general guidance.

3.1.2 The boiler must be installed so that the terminal is exposed to the external air. It is important that the position of the terminal allows the free passage of air across it at all times.

3.2 WALL THICKNESS (see diagram 2)

Check the wall thickness where the boiler is to be fitted. The standard terminal supplied suits 238 to 330mm ($9\frac{3}{8}$ - 13 in.). A short terminal to suit 146 to 238mm ($5\frac{3}{4}$ - $9\frac{3}{8}$ in.) and extension sleeves to suit 330 to 578mm (13 in - $22\frac{3}{4}$ in.) are available to special order.

3.3 TERMINAL POSITIONING

3.3.1 The minimum acceptable spacings from the terminal to obstructions and ventilation openings are specified in TERMINAL POSITIONING TABLE.

3.3.2 Where the terminal is within 850mm, (34 in), below plastic guttering, an aluminium shield 1.5m, (5 ft), long should be fitted to the underside and immediately beneath the guttering.

3.3.3 The air inlet/products outlet duct and the terminal of the boiler must not be closer than 25mm, (1 in.), to combustible material. Detailed recommendations on protection of combustible material are given in BS5440 Part 1.

3.4 PROTECTING THE TERMINAL

3.4.1 Where the terminal is less than 2m, (6ft 6in.) above the level of any ground, balcony, flat roof etc. to which any person has access and which adjoins the wall in which the terminal is situated, the terminal must be protected by a guard of durable material.

3.4.2 Guards are available from Tower Flue Components Ltd., telephone Tonbridge 351555, quoting reference 'D' or from Quinnell, Barrett and Quinnell Ltd., 884 Old Kent Road, London S.E.15, quoting reference type 'E'.

3.5 ROOM VENTILATION

Where the boiler is fitted in a room, the boiler does not require the room containing it to have a permanent air vent.

3.6 CUPBOARD/COMPARTMENT VENTILATION

Where the boiler is fitted in a cupboard or compartment, the ventilation area must be in accordance with AIR VENT TABLE.

NOTE: Both the high level and low level air vents must communicate with the same room or must both be on the same wall to outside air.

4.1 LOCATION OF PARTS AND CONTENTS OF PACKAGING

PACK 1

Boiler Chassis - Main Body of Boiler
Outer Case
Wall Frame
Burner
Rear side panels
Combustion chamber shield
Fixing Pack (Screws, Wallplugs etc.)
User and Installation Instructions.

PACK 2 See Identification Box on Carton for Type.

Basic Model:-
Controls Cabinet
Controls Drawer (Basic)
Piezo Unit
Door and Base Assembly (Basic)
Bag of Fixings
(Note: A programmer controls cabinet is available).

PACK 3

Balanced Flue Terminal. Refer to 3.2 to check that the flue supplied is suitable.

4.2 UNPACKING THE BOILER

4.2.1 Remove outer packing to reveal white outer casing.

4.2.2 Remove the two screws which fix the top of the outer casing to the chassis. Keep all loose fastenings safely.

4.2.3 Slide the white casing about 25mm, (1in.), upwards to disengage it from the chassis, and remove it, gently tilting and easing casing to avoid damage.

4.2.4 Put the casing in safe place.

4.2.5 Remove the two boiler fixing screws, see diagram 8, to allow the frame to disengage from chassis of boiler. Turn the boiler over on it's front, ready for piping up. The outer packaging may be flattened and used to protect the boiler and the floor.

5 INSTALLATION

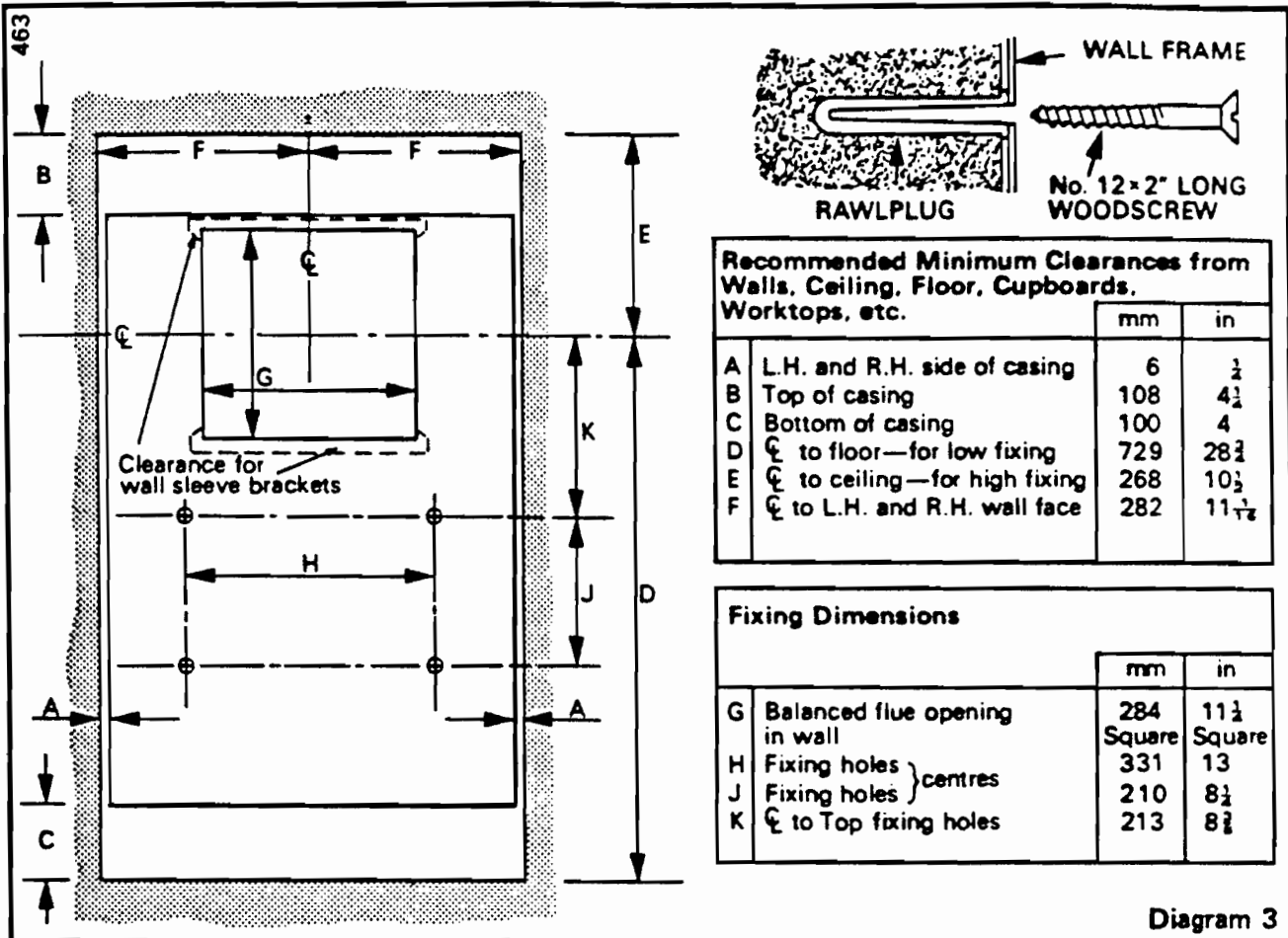

5.1 Mark out the wall surface with the positions for the flue duct and wall frame fixing screw holes as shown in diagram 3.

5.2 Cut out the hole for the flue duct. On outside brickwork face, clear edge of hole on the top and bottom faces for the brackets and screws on the wall sleeve.

5.3 Drill holes to suit wallplugs supplied at the fixing screw positions.

5.4 Fix the wall frame to the inner surface of the wall, using the wallplugs and wood screws supplied.

5.5 WATER CONNECTIONS (USE ONLY SUITABLE FITTINGS).

5.5.1 Fit the appropriate fitting into the boiler tappings as required, see diagram 4 and 5.

5.6 GRAVITY DOMESTIC HOT WATER WITH PUMPED HEATING.

It is important that the arrangement illustrated in diagram 4 is adopted when the gravity domestic hot water connections are being prepared. The domestic return pipe must be on the same side as the domestic flow.

The heating flow and return pipes are taken from the other side of the boiler.

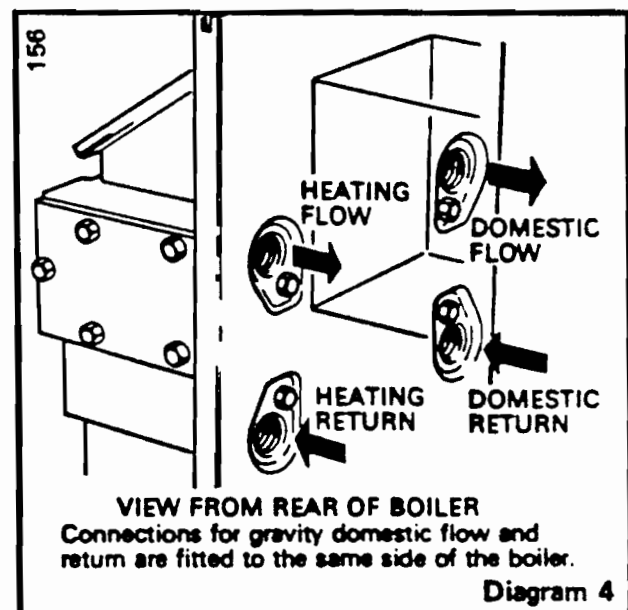

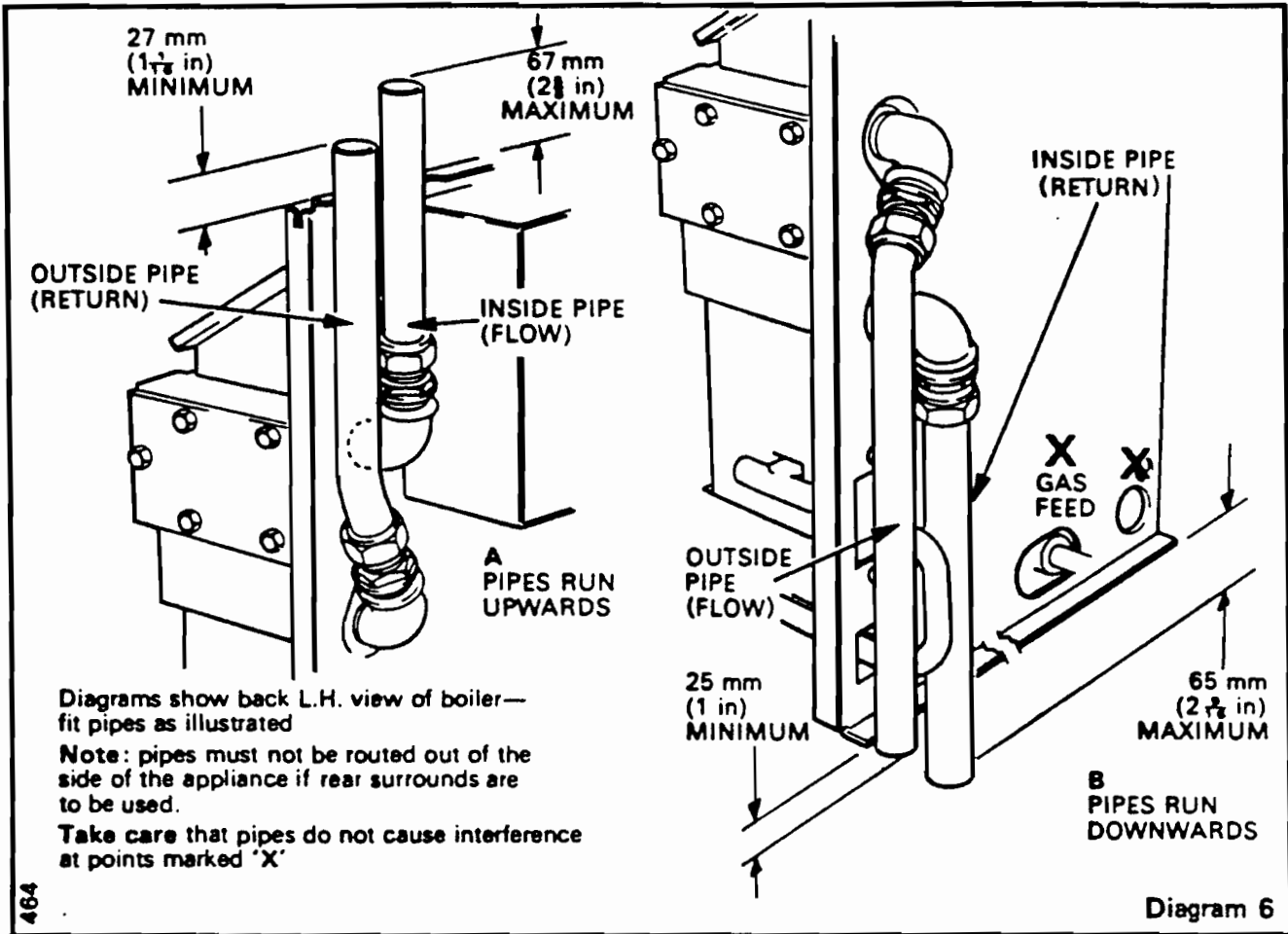

5.7 PUMPED HEATING AND HOT WATER.

It is important that all connections are made as illustrated in diagram 5. The connections may be fitted on opposite side to that shown, but always in the same relative positions.

5.8 Fit the water pipes with compression fittings to terminate above the top edge of the main panel or below the bottom edge, as required. The dimensions shown in diagram 6 will allow the compression fittings to be accommodated when the boiler is fitted with minimum clearances. When a larger clearance is available, these pipe lengths may be adjusted accordingly.

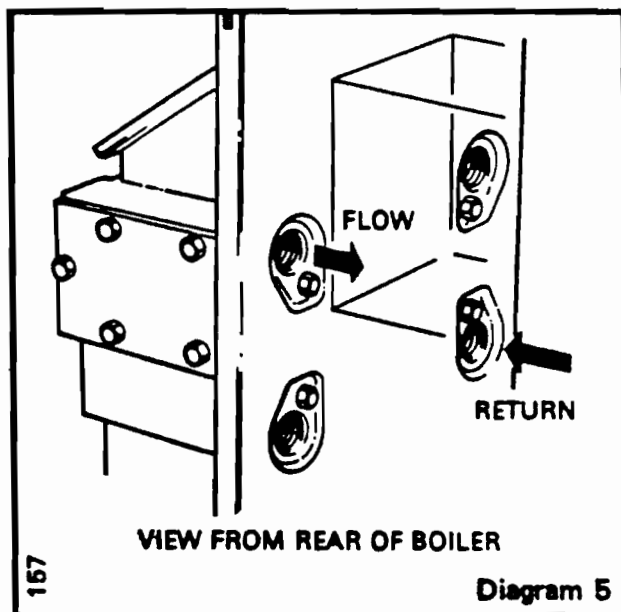

5 INSTALLATION

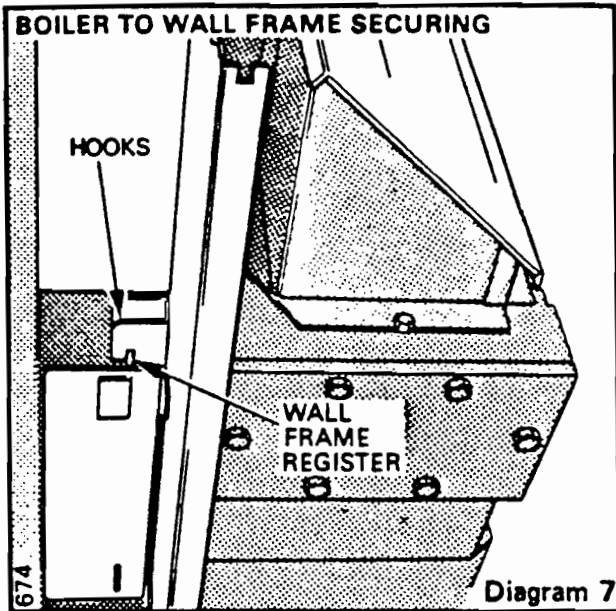

5.9 Offer the boiler to the wall frame squarely and vertically and position the hooks on the main panel over the top edge of the wall frame, see diagram 7. Ensure that the boiler is central on the wall frame, the hooks being inside. Secure the boiler to the wall frame with the two No.12 x 1 in. long self-tapping pan hd. screws and plain washers supplied, in the position shown in diagram 8.

5.10 Take the outer section of the balanced flue, see diagram 9, and remove the four screws 'F'. This releases the outer baffle 'E'. Remove the

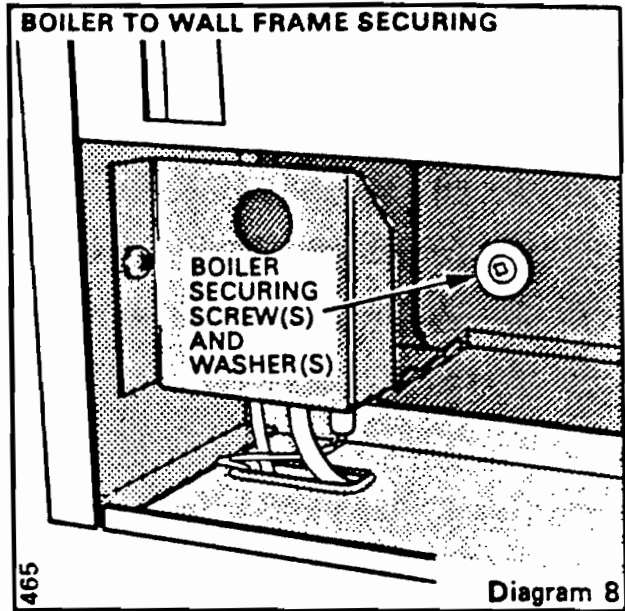

four wire guards 'D' from the slots in the spacers and then pull off the inner baffle and sleeve assembly 'C'.

5.11 Place the outer wall sleeve 'A' centrally into the prepared hole in the wall from outside, engaging it over the outer flue duct on the boiler. It may be necessary to chase away the outer wall surface locally to the top and bottom fixing angles on the outer wall sleeve, see diagram 3, to allow the terminal frame to be flush with the wall.

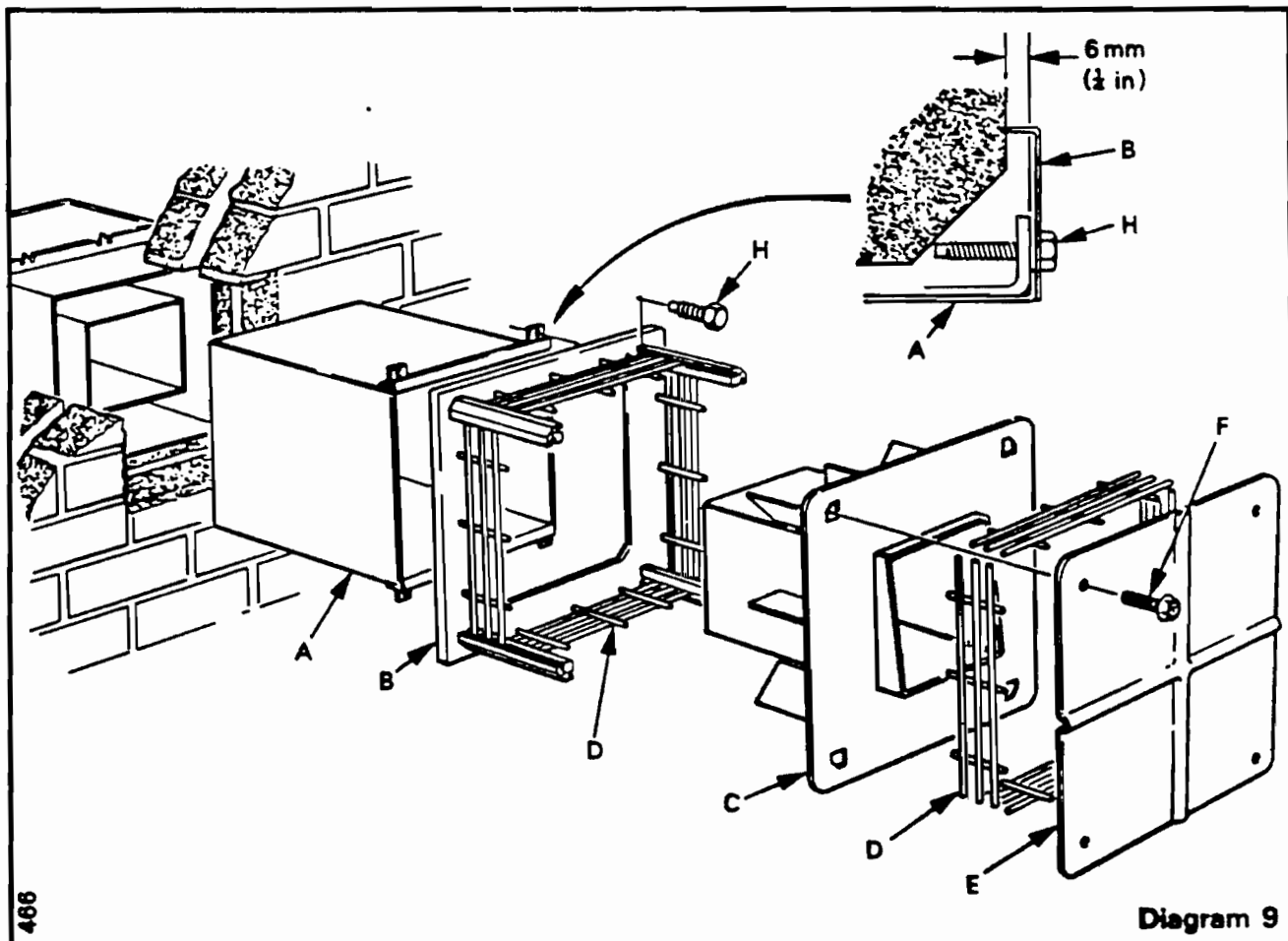

- 5.12 Cement the wall sleeve in position, ensuring that the brackets are clear of cement and stand 6mm ($\frac{1}{4}$ in) proud of the wall surface, see diagrams 9 and 3.
- 5.13 Seal between the wall sleeve and outer flue duct with the sealant strip provided.
- 5.14 The terminal frame 'B', with the aluminium spacers and inner wire guards still in position, can now be secured to the brackets on the wall sleeve with the four M6 x 20mm dogpoint screws 'H' provided. Note that the terminal frame is fitted with the face marked 'TOP' uppermost.
- 5.15 Refit the parts removed in 5.10, again making sure that the face of inner baffle 'C' marked 'TOP' is uppermost. Seal between the inner sleeves with the sealant strip provided, before re-fitting outer baffle.
- 5.16 Complete the water connections to the pipes previously fitted, using compression fittings.
- 5.17 Make the gas connection to the Rc $\frac{1}{2}$ union gas cock in the controls area of the boiler.
- 5.18 Remove the combustion chamber shield from the packing
- 5.19 Remove the burner from the packing, refer to diagram 10 and fit as follows:-
- 5.19.1 Offer burner into combustion chamber inclined upward at the locating pin, left hand, end to clear the pilot bracket.
- 5.19.2 Fit the hole in the venturi strap at R.H. end over the injector.
- 5.19.3 Lower the locating pin into the plunged hole in the pilot bracket, ensuring that it is seated correctly.
- 5.20 Fit combustion chamber shield.

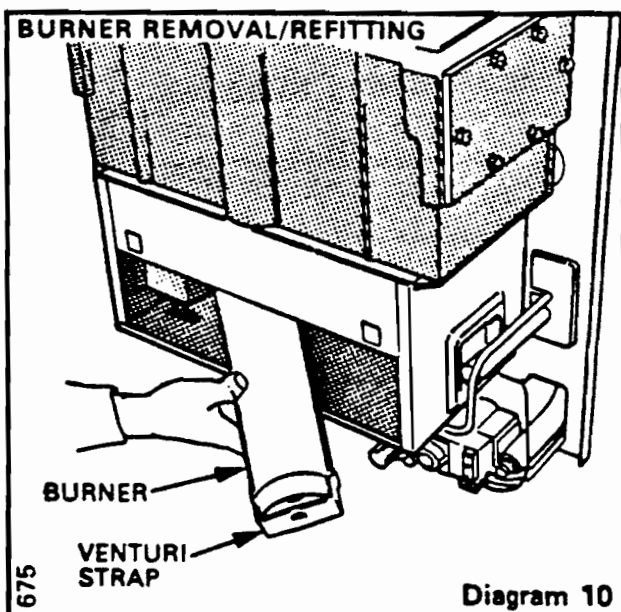

- 6.1 Open the controls pack - see 4.1 for list of contents. Remove the screws securing the base/door assembly of the controls cabinet, see diagram 11, remove the assembly and put in a safe place. Remove the screw securing the controls drawer to the controls cabinet and completely remove the controls drawer. See diagram 12.
- 6.1.2 Screw the controls cabinet to the bottom of the main panel using the six screws provided, see diagram 11. Connect the loose end of the ignition lead to the Piezo Unit at the L.H. side of the controls cabinet.
- 6.2 Remove the L.H. gland plates, diagram 11.
- 6.2.1 Supporting the controls drawer, feed the thermostat phial through the large plunged hole in the bottom L.H. side of the main panel and through the gland plate aperture. Engage the controls drawer on to its slides in the underside of the controls cabinet sufficiently to support the drawer.
- 6.2.2 Fit the phial into the phial pocket, pushing fully down and securing with the retaining split pin, supplied in the loose item bag.
- 6.2.3 Ensure that there is clearance between the thermostat capillary and the boiler.
- 6.2.4 Replace the L.H. Gland plates.

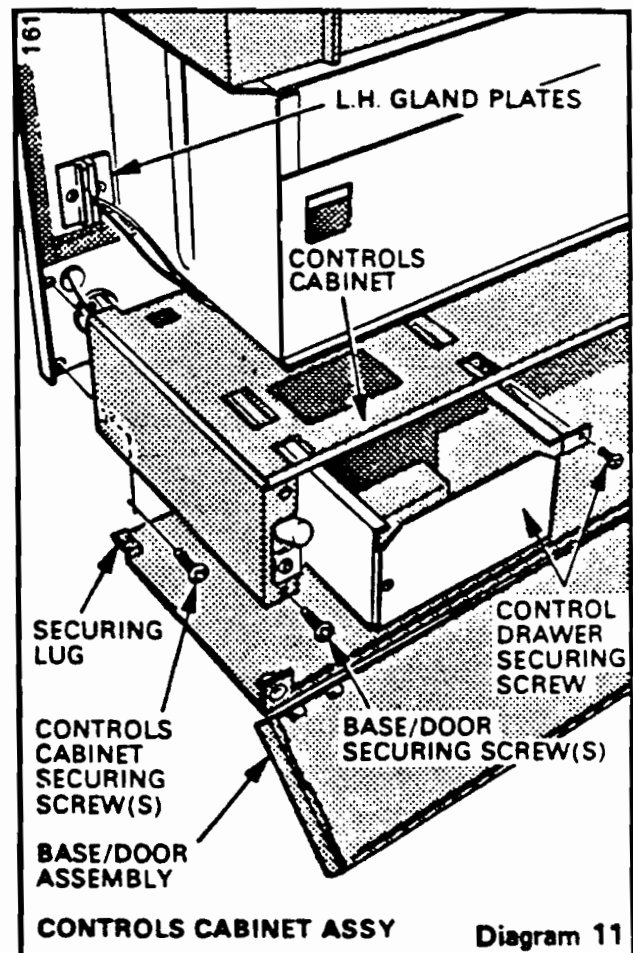

- 7.1 Feed the mains cable from the rear, through the large plunger hole in the bottom L.H. side of the main panel.
- 7.2 Pass the mains cable over the rear lip of the controls drawer and through the cable clamp, see diagram 12. Connect the three cables to the appropriate terminals in the terminal block and tighten the screws in the cable clamp, make the earth cable longer than the live and neutral cables.
- 7.3 In the event of an electrical fault after installation of the appliance, preliminary system checks must be carried out (i.e. earth, continuity, polarity and resistance to earth as described in the British Gas Multimeter Instruction Book.)
- 7.4 Identify cable clip "S", diagram 14, taken from plastic bag. Fit to the front edge of hole above the gas valve, in the controls cabinet top.
- 7.5 Pass the orange gas valve cable through the large plunger hole in the main panel, across the back of the panel, in through the aperture at the R.H. side of the valve and via the cable clip above the gas valve. Connect to the gas valve.
- 7.6 Push the controls drawer fully home and secure with the screw previously removed, making sure that the shakeproof washer is in place and that the screw is fully tightened.
- 7.7 Refit door/base assembly - a reverse of 6.1.

8. CONTROL SCHEMES

ADVISE THE USER WHICH SCHEME IS USED WITH THIS BOILER AND GIVE GUIDANCE ON THE OPERATION OF THE CONTROLS.

These diagrams are schematic and for information only. The installation must comply with the current issue of the I.E.E. Wiring Regulations. All cables and connections must be of the approved type, refer to 1.3 'Electrical'.

Scheme 1 Pumped hot water and heating, using one spring return valve, 10 position programmer.

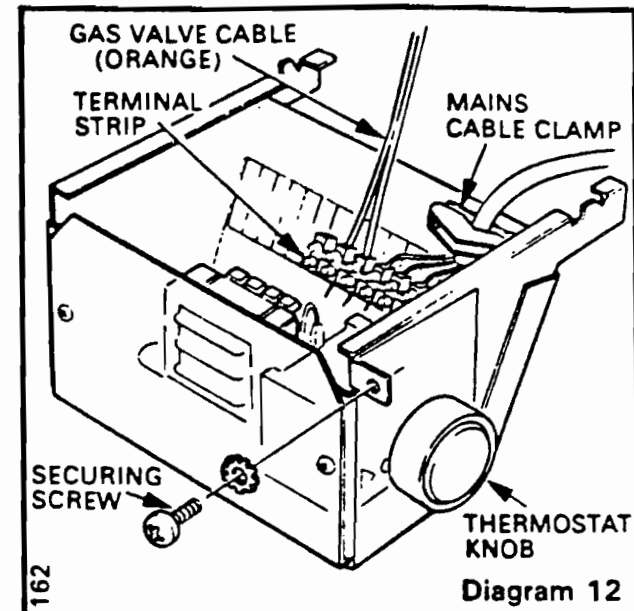

Scheme 2 Honeywell Sundial Plan Y.

Follow Honeywell instructions for piping and controls installation.

Scheme 3 Independent control of hot water and heating, both pumped, using two spring return valves, 16 position programmer.

Scheme 4 Pumped hot water and heating, using a Brayton Flow-share valve.

Scheme 5 Satchwell Duoflow system, 16 position programmer. Remove links A and B from RJ2802 wiring centre.

Scheme 6 Independent control of hot water and heating, both pumped, using two motorised valves, 16 position programmer.

Scheme 7 Pumped hot water and heating, one motorised valve, 10 position programmer.

Scheme 8 Gravity hot water, pumped central heating, ten position programmer.

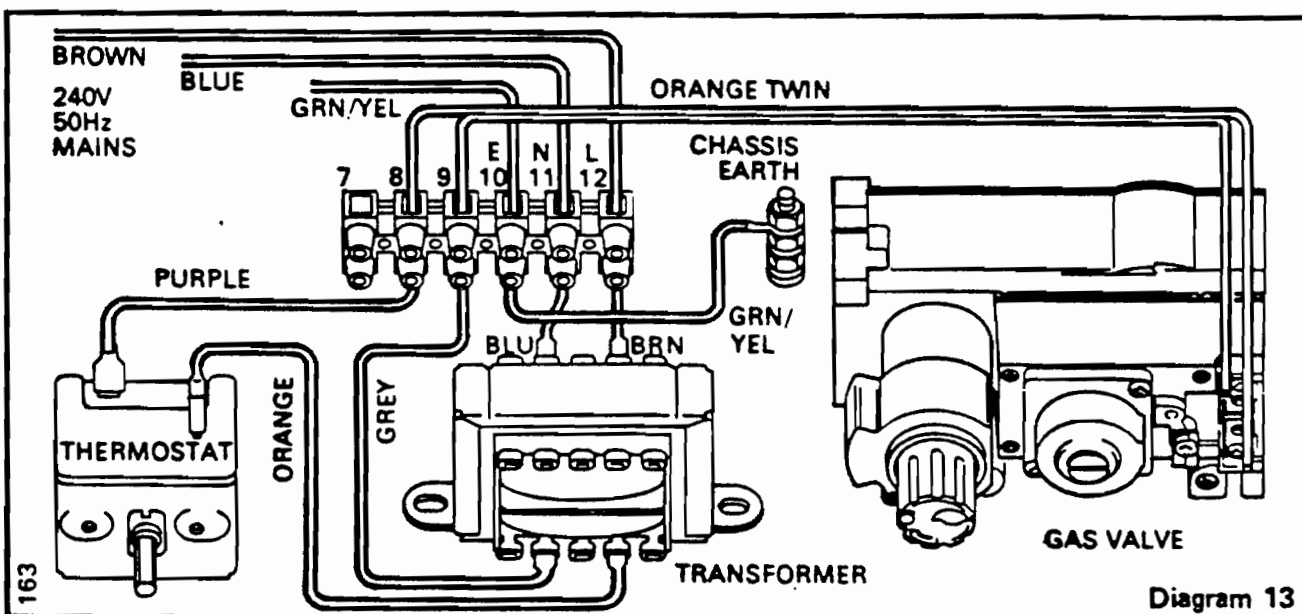

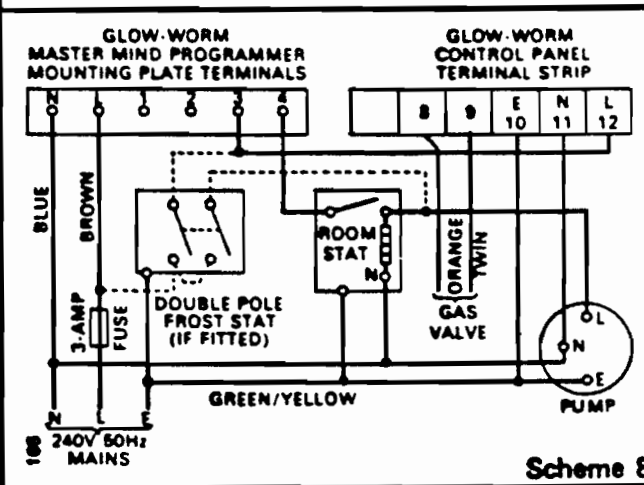
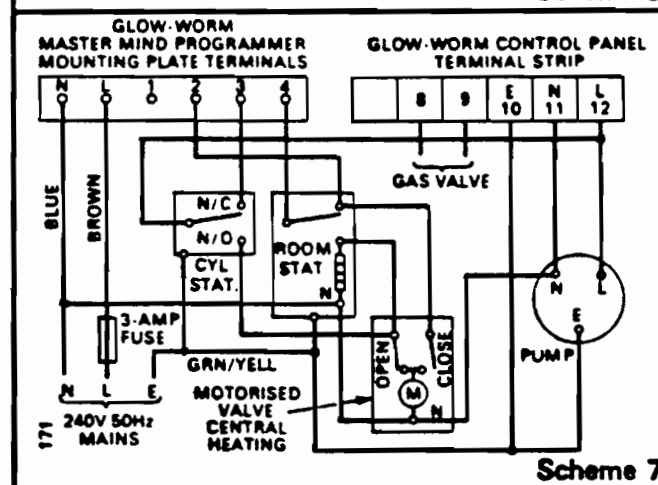
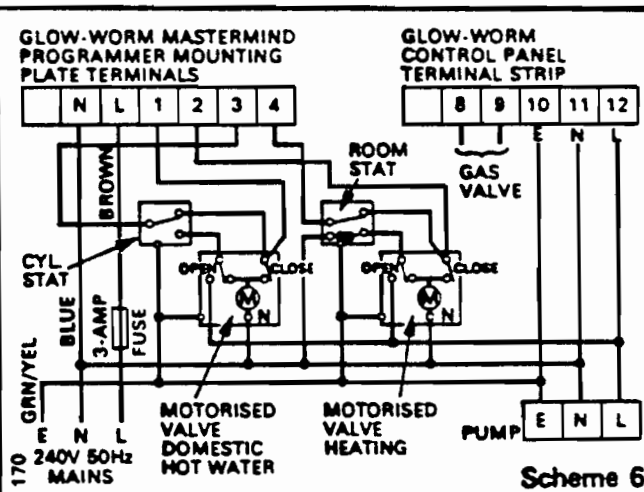
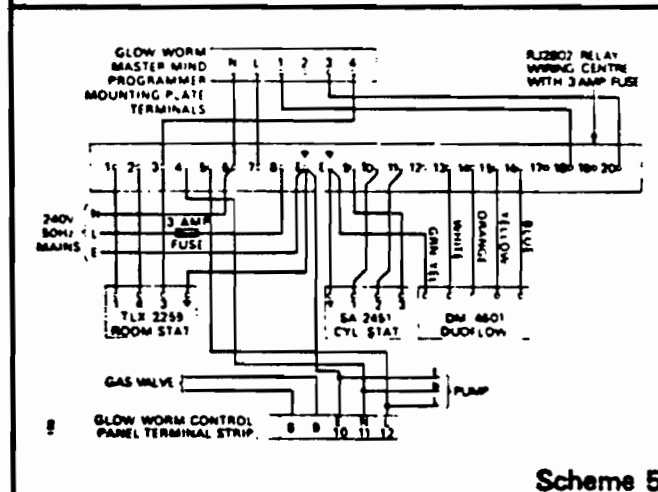
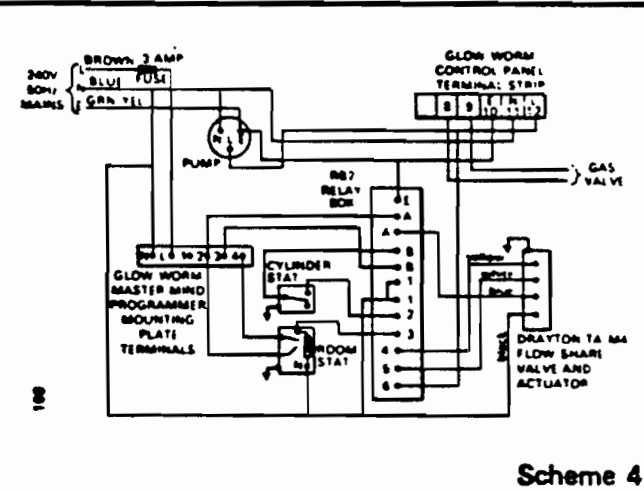
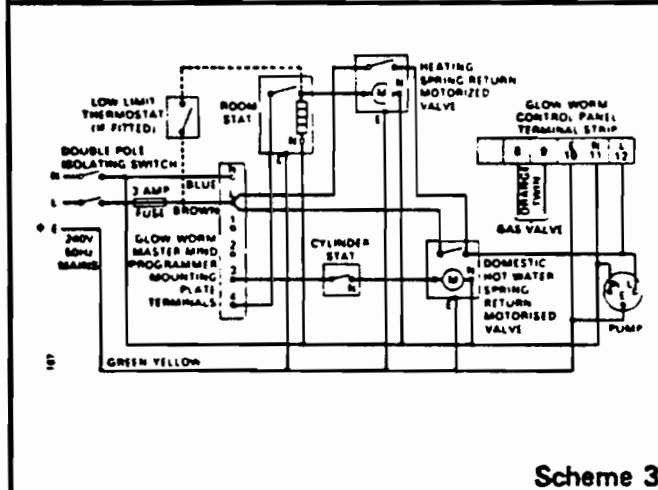
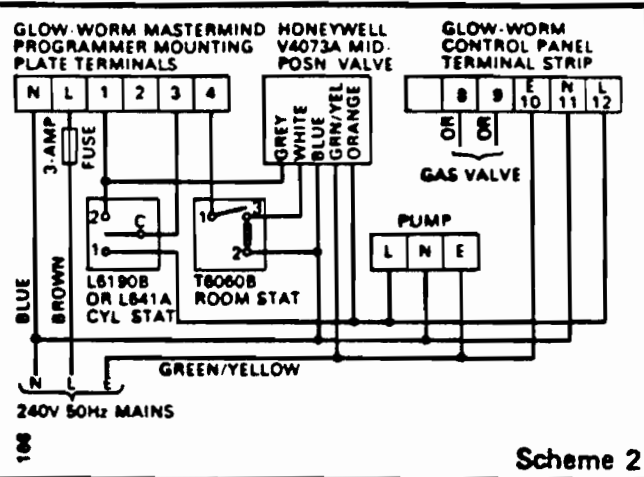
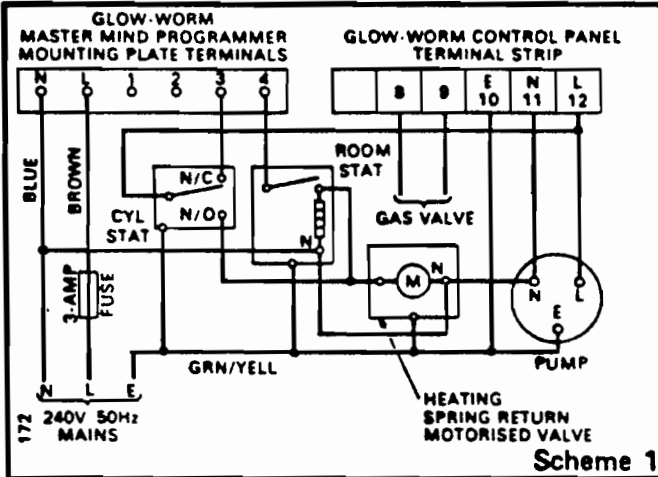

9 COMMISSIONING

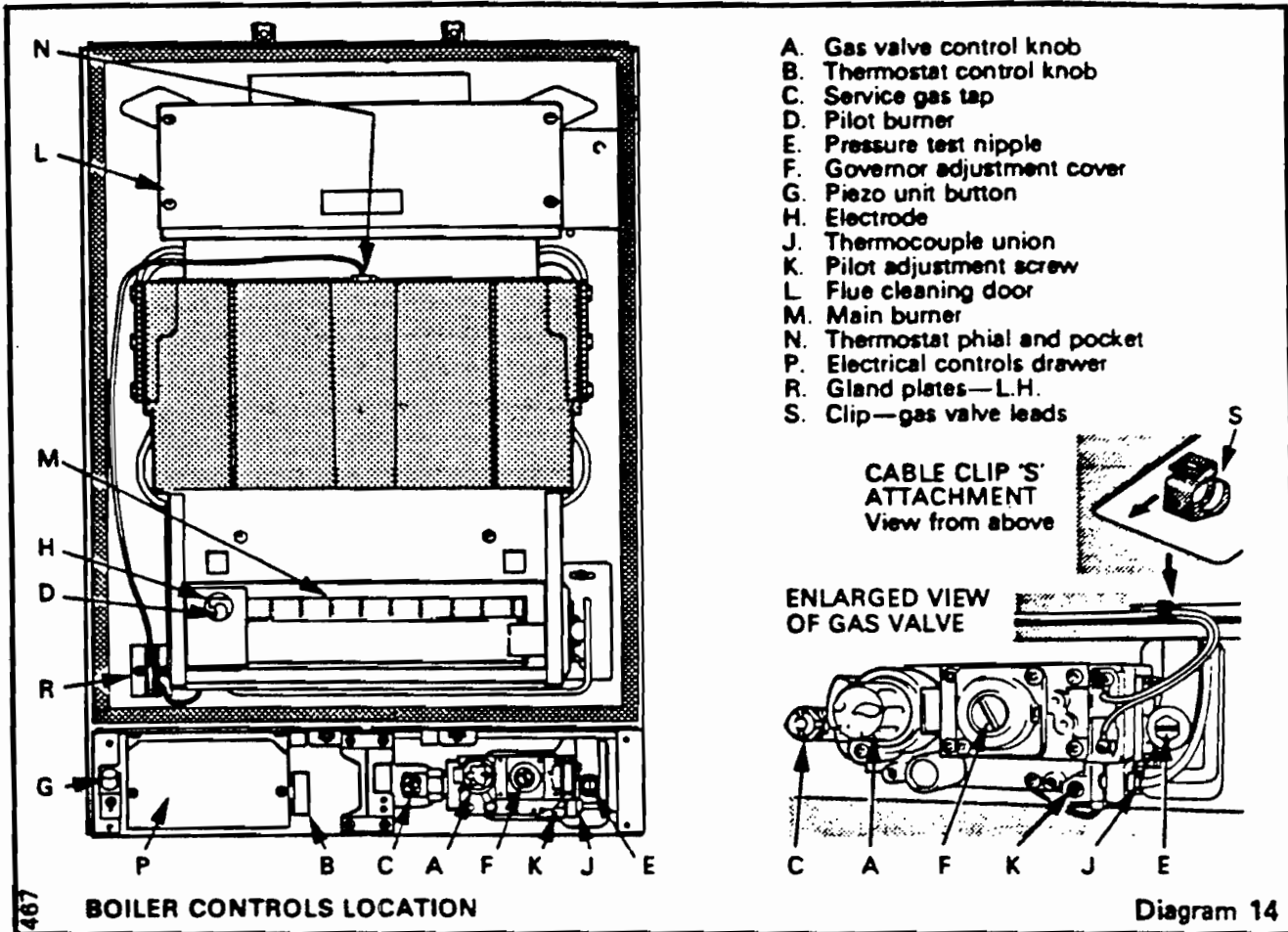

467

BOILER CONTROLS LOCATION

Diagram 14

9.1 ELECTRICAL INSTALLATION

Checks to ensure electrical safety should be carried out by a competent person.

9.2 GAS INSTALLATION

The whole of the gas installation should be tested for soundness and purged in accordance with the recommendations of CP331 Part 3.

9.3 WATER CIRCULATION SYSTEM

The whole of the system should be thoroughly flushed out with cold water. Ensure that all valves are open. The system should then be filled with water and air locks cleared. Examine for water soundness.

9.4 INITIAL LIGHTING, TESTING & ADJUSTMENT

CAUTION: The following procedure should be carried out by a qualified gas service engineer. The pipes and fittings to the burner will contain an amount of air and it will be necessary to purge the air before the boiler can operate normally. Identify the boiler controls with relevant details on diagram 14.

- 9.4.1 Check that the service gas tap 'C' is closed, that is, the indicator line is vertical.
- 9.4.2 Make sure that the thermostat phial is pushed down to the bottom of the phial pocket.
- 9.4.3 See that the mains electricity supply is switched off.

9.4.4 Set thermostat control knob 'B' to '0' the off position.

9.4.5 Remove gas pressure test nipple screw 'E' and connect a suitable pressure gauge.

9.4.6 Open service gas tap 'C'

9.4.7 Depress gas valve control knob 'A' fully and hold. Depress and release the piezo unit button 'G' until the pilot burner lights. At this stage, air may be present in the gas pipes and this operation may need to be repeated until all the air has been expelled. When the pilot burner lights, keep control knob 'A' fully pushed in for approx. 20 seconds to heat the thermocouple. If the pilot burner fails to light or stay alight, wait **THREE MINUTES** then repeat exactly the above sequence.

The pilot burner flame envelopes 10 to 13mm, ($\frac{3}{8}$ to $\frac{1}{2}$ in.) of the thermocouple tip.

The pilot gas rate can be adjusted if necessary as follows:- Identify pilot adjustment screw 'K' turn anti-clockwise to increase pilot flame.

9.4.8 If gas valve control knob 'A' is turned to '0' the off position a safety lock prevents it being fully depressed again until the thermocouple has cooled, to prevent attempted re-light in an unsafe condition. No attempt should be made to depress knob 'A' until the three minutes have elapsed.

9.4.9 Make sure that the burner pilot is alight and stable, then switch electricity supply on. Set clock or programmer to an 'ON' position and

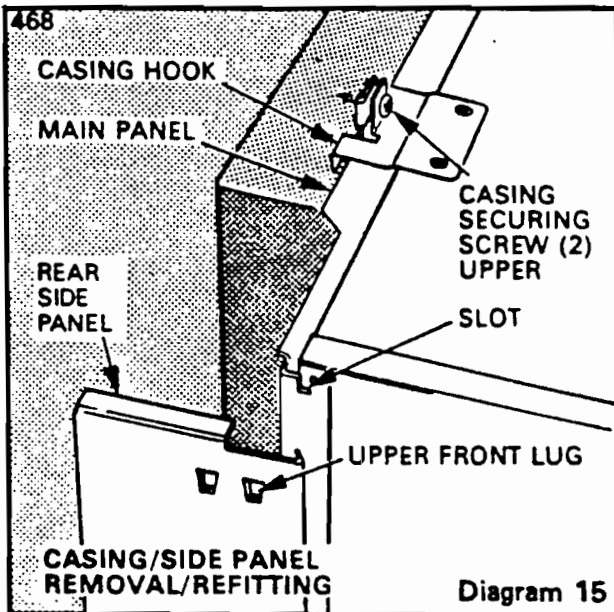
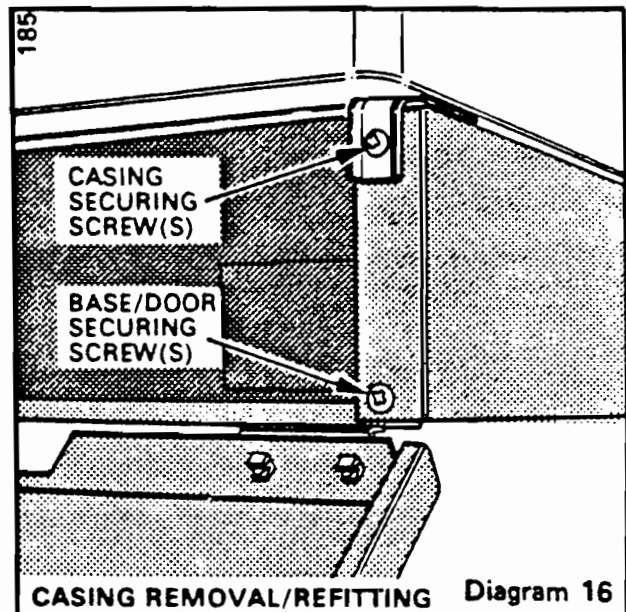

Diagram 15



CASING REMOVAL/REFITTING Diagram 16

ensure that any other controls are calling for heat. Set thermostat control knob 'B' between 'MIN' and 'MAX' opposite the marker on the control box; the main burner will then light. ('MAX' approx. 82°C, 180°F).

9.4.10 Test for gas leakage around boiler gas components using leak detection fluid.

9.4.11 Set burner gas pressure after ten minutes from lighting (See page 2 for setting pressure). To do this, remove governor adjustment cover screw 'F' and adjust the internal screw to obtain the required pressure. Turn clockwise to increase pressure and anti-clockwise to decrease pressure. Replace the cover screw.

9.4.12 Check operation of the flame failure device as follows:- With the main burner alight, turn gas valve control knob 'A' clockwise to its stop, this will extinguish main and pilot flames. Relighting the appliance will not be possible as the safety device in the gas valve has been activated. Before 60 seconds have elapsed the flame failure device should have closed, (a click from the gas valve will indicate its operation). Do not attempt to relight until 3 minutes have elapsed. Remove the pressure gauge and refit the pressure test nipple screw 'E'.

9.4.13 Turn thermostat 'B' to 'O' then relight the boiler pilot burner as in 9.4.7.

9.4.14 Check that the boiler thermostat and all automatic controls are operating satisfactorily.

9.4.15 Fit the outer casing by offering up squarely and vertically to the boiler, ensuring that the lower part of the casing clears the pilot tube. Lift approximately 10mm so that the hook section at the top rear of the casing fits over the main panel, see diagram 15 and lower approx. 10mm into position. Secure with the two No.12 x 1 in. long self-tapping screws at the top and two M5 Pozipan dogpoint screws in the lower position, see diagram 16.

9.4.16 Re-light the main burner and check for gas leakage around pressure test screw 'E'.

9.4.17 Allow the water system to warm up and then set the pump adjuster to a design position which gives the correct temperature difference of 11°C, (20°F), between the flow and return pipes. There should be no undue noise in the pipework or emitters and no pumping over of system water at the vent pipe.

9.4.18 Allow the water system to reach maximum working temperature and examine for water soundness. The system should then be turned off and rapidly drained while still hot to complete the flushing process. The system should again be filled with water and cleared of air locks. Examine for water soundness.

9.5 If required fit the rear side panels by engaging the front lugs on to the cut-outs on the main panel sides, see diagram 15.

9.6 USER INSTRUCTIONS

9.6.1 Hand the User's Instructions to the user or purchaser for retention. Instruct and demonstrate the efficient and safe operations of the boiler and heating/hot water system.

9.6.2 Advise the user or purchaser that for continued efficient and safe operation of the boiler it is important that adequate servicing is carried out at intervals recommended by the local region of British Gas.

Servicing must be carried out by a qualified gas service engineer and where appropriate, by a qualified electrician.

BEFORE COMMENCING A SERVICE, TURN OFF THE GAS SUPPLY AT THE MAIN SERVICE COCK AND ISOLATE THE ELECTRICITY SUPPLY.

10.1 BOILER FLUEWAYS

10.1.1 Remove the outer casing by undoing the four screws shown in diagrams 15 and 16, lift the case approx. 10mm and withdraw.

10.1.2 Remove the combustion chamber shield, see diagram 17, by lifting slightly to clear the lugs and withdraw. Remove the burner by lifting the L.H. end so that the location pin clears its seating, then move to the left so that the R.H. end clears the injector. Withdraw the R.H. end first from the combustion chamber, taking care not to damage the electrode or pilot burner.

10.1.3 Remove the flue cleaning door by removing the screws and lifting off.

10.1.4 Place a sheet of paper in the combustion chamber, over the pilot burner, to catch the flue debris.

10.1.5 Clean the boiler flueways and fins thoroughly with a suitable stiff brush.

10.2 BURNER

With the burner removed as above, clean thoroughly.

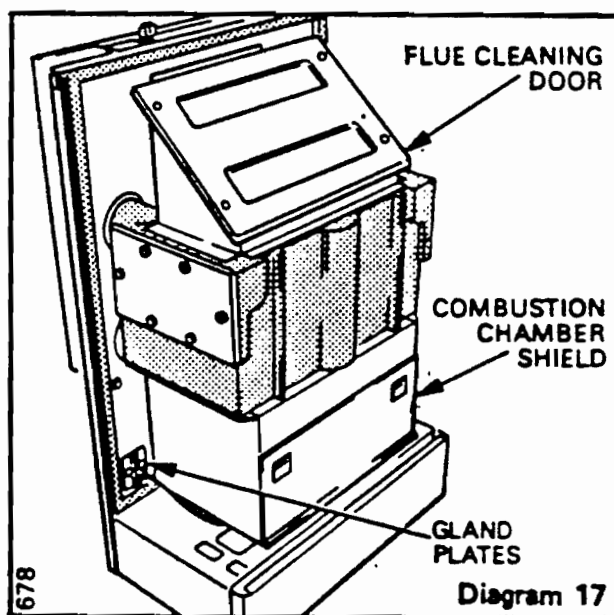

Diagram 17

BEFORE REMOVING OR REPLACING ANY PARTS, TURN OFF THE GAS SUPPLY AT THE BOILER, SERVICE TAP 'C', DIAGRAM 14 AND ISOLATE THE BOILER FROM THE ELECTRICITY SUPPLY.

Note

11.1 Remove controls base/door assembly by removing the two screws, see diagram 16.

Note

11.2 Remove the casing, see text 10.1.1.

Note

11.3 Remove the casing and burner, see text 10.1.1 and 10.1.2.

Note

11.4 All items are replaced in reverse order, except where noted.

11.5 GAS VALVE (See note 11.1)

11.5.1 Disconnect the orange electrical leads, thermocouple nut and pilot tube connections at the gas valve, see diagram 18.

11.5.2 Disconnect the union nut at the gas cock, at the left of the gas valve.

11.5.3 Remove the four screws securing the gas valve to the flange on the burner supply tube at right. Take care not to damage the 'O' ring seal, should any damage occur then a new 'O' ring, Item No. 2 on the list of replacement parts must be fitted. The gas valve is now free and can be removed.

11.5.4 When screwing the union half fitting into the replacement valve, use a little jointing compound on the threads to ensure a gas-tight seal.

11.5.5 Re-assemble in reverse order to that described, carefully re-fitting the 'O' ring in the valve recess. Do not tighten thermocouple nut more than one quarter turn beyond finger tight, making sure that the connector lead is fitted into the slot in the valve, see diagram 18. It will be necessary to purge the system of air after changing the gas valve and re-lighting should be carried out as in 9.4 INITIAL LIGHTING AND ADJUSTMENT.

11.6 INJECTOR (See note 11.3)

11.6.1 When the burner is removed, as in 10.1.2, the injector can be seen at the R.H. side of the combustion chamber. It can be unscrewed and replaced as necessary. When replacing, use a little jointing compound on the threads to ensure gas soundness.

11.7 PILOT BURNER (See note 11.2)

11.7.1 Remove the pilot shield by removing the screw and nut securing it to the combustion chamber side (See diagram 19).

11.7.2 Release the cover plate and swing forwards, under the combustion chamber, (see diagram 20). Pull out the clip holding the thermocouple into the pilot burner and pull the thermocouple downwards out of the pilot burner.

11.7.3 Disconnect the lead from the electrode and remove the hex. nut from the stud securing the electrode to the pilot bracket then remove the electrode.

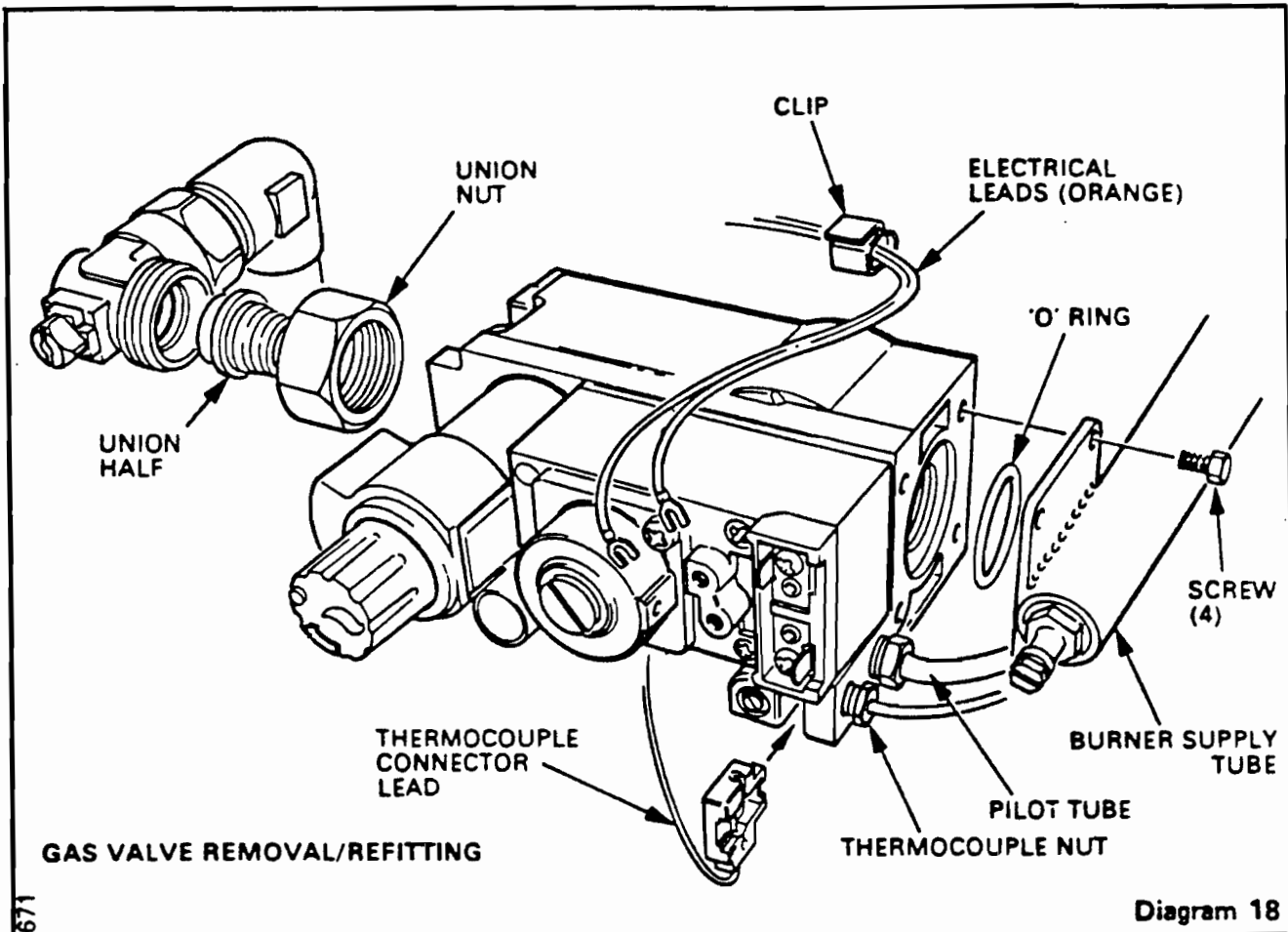

Diagram 18

11.7.4 Disconnect the pilot union at the base of the burner using two spanners, one on the union nut and the other on the hexagon immediately above the union nut.

11.7.5 Slacken the nut securing the pilot burner at the left. The pilot burner can now be removed.

11.7.6 Check the spark gap, (see diagram 21).

11.7.7 Make sure that the pilot flame envelops the thermocouple tip by 10 to 13mm, (3/8 to 1/2in.). Flame length approx. 13mm, (1/2in.).

11.8 THERMOCOUPLE. (See notes 11.1 and 11.2)

11.8.1 Remove front pilot shield as in 11.7.1. Release the cover plate as in 11.7.2. The thermocouple can then be removed after releasing the clip securing it to the pilot and pulling it downward.

11.8.2 Disconnect from the gas valve by unscrewing nut, see diagram 18 and remove the two gland plates on the boiler back plate, (see diagram 17). The thermocouple can now be withdrawn.

11.8.3 To refit the thermocouple, feed the gas valve end downwards through the cut-out in the combustion chamber base, then via the gland plate aperture, across the back of the main panel, to come through the aperture at the right of the gas valve and connect at the gas valve, making sure that the connector lead is fitted into the slot in the valve, (see diagram 18). Do not tighten this more than one quarter turn beyond finger tight.

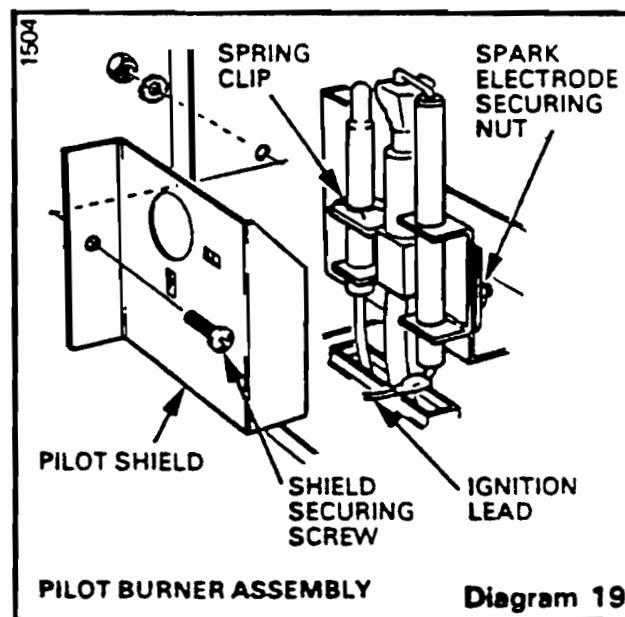

Diagram 19

11.8.4 Connect the other end of the thermocouple to the pilot burner and secure with the clip. Refit the gland plates, ensuring that a good seal is made.

11 REPLACEMENT OF PARTS

11.9 ELECTRODE (See note 11.2)

11.9.1 Remove pilot shield as in 11.7.1. Disconnect the ignition lead and remove the nut from the stud securing the electrode, then remove it.

11.9.2 Replace by reversing the above procedure and ensure that the electrode is correctly positioned, see diagram 19.

11.10 ELECTRICAL CONTROL DRAWER (See note 11.1 and 11.2)

11.10.1 Remove the control drawer securing screw, see diagram 12.

11.10.2 Remove the retaining split pin then remove thermostat phial from the pocket.

11.10.3 Remove the gland plates on the boiler back plate, see diagram 17.

11.10.4 Remove the orange gas valve cable from its clip above the valve.

11.10.5 Slide the control drawer forwards far enough to disconnect all electrical connections. The drawer can then be removed, withdrawing the thermostat capillary through the back panel.

11.10.7 Replace in reverse order, for details of wiring see diagram 13. Ensure that the thermostat phial is fully pushed down to the bottom of the pocket and secured with the retaining split pin. Leave clearance between capillary and boiler, also make a good seal at the gland plates, see diagram 17.

11.11 BOILER THERMOSTAT (See notes 11.1 and 11.2)

11.11.1 Slide control drawer forwards as in 11.10, pull off thermostat control knob.

11.11.2 Slacken the screw securing the thermostat capillary clip to the control drawer and release the capillary.

11.11.3 Disconnect the two connectors on top of the thermostat. Remove the screws securing the thermostat, and the front cover of the control drawer. The thermostat may now be removed.

11.11.4 Replace in reverse order, making sure that the connectors on the thermostat are at the top. Leave clearance between capillary and boiler, also make a good seal at the gland plates. Ensure that the thermostat phial is fully pushed down to the bottom of the pocket and secured with the retaining split pin.

11.12 IGNITION LEAD (See note 11.2)

11.12.1 Remove combustion chamber shield by lifting slightly to clear the lugs, then withdraw, see diagram 17.

11.12.2 Remove L.H. gland plates, see diagram 17.

11.12.3 Slide controls drawer forward as in 11.10.

11.12.4 Pull off the connector at the electrode, the lead can then be removed.

11.12.5 Replace in reverse order, making sure that the gland plates make a good seal.

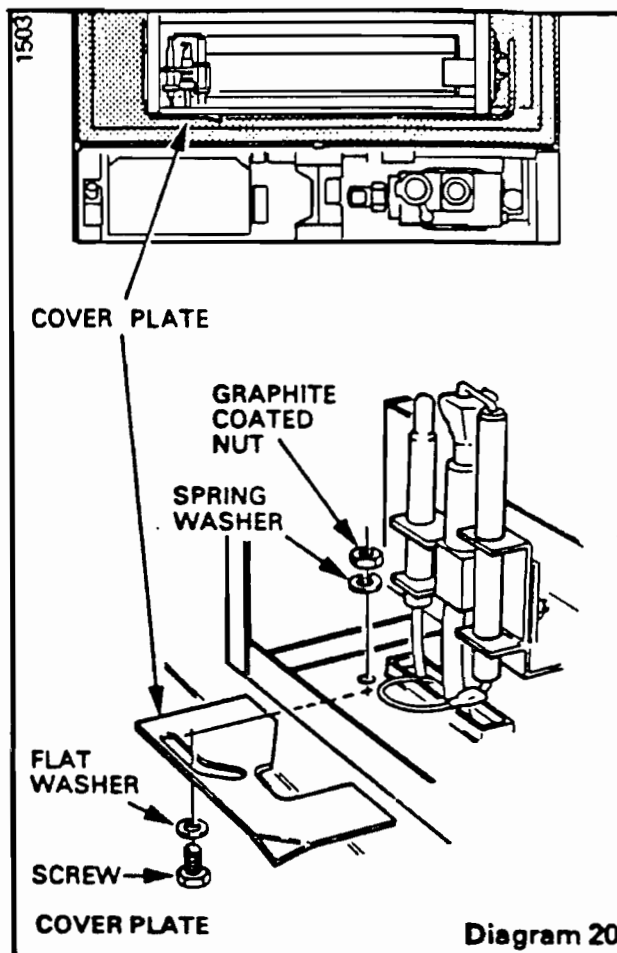

Diagram 20

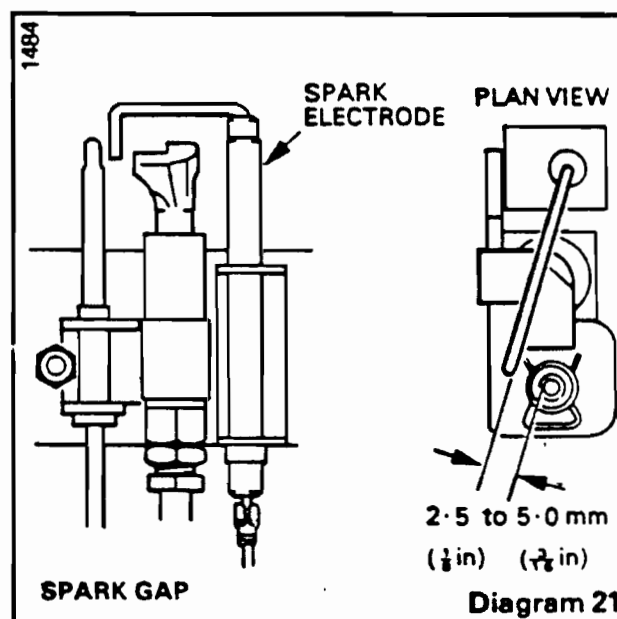

Diagram 21

11.13 PIEZO UNIT

11.13.1 Open controls door and remove the control drawer securing screw, see diagram 12. Pull the control drawer forward off its slide.

11.13.1 Pull off ignition lead from the tag on the piezo unit.

11.13.2 The piezo unit can now be removed by removing the screw securing it to the front of the controls cabinet.

PILOT WILL NOT LIGHT
START HERE

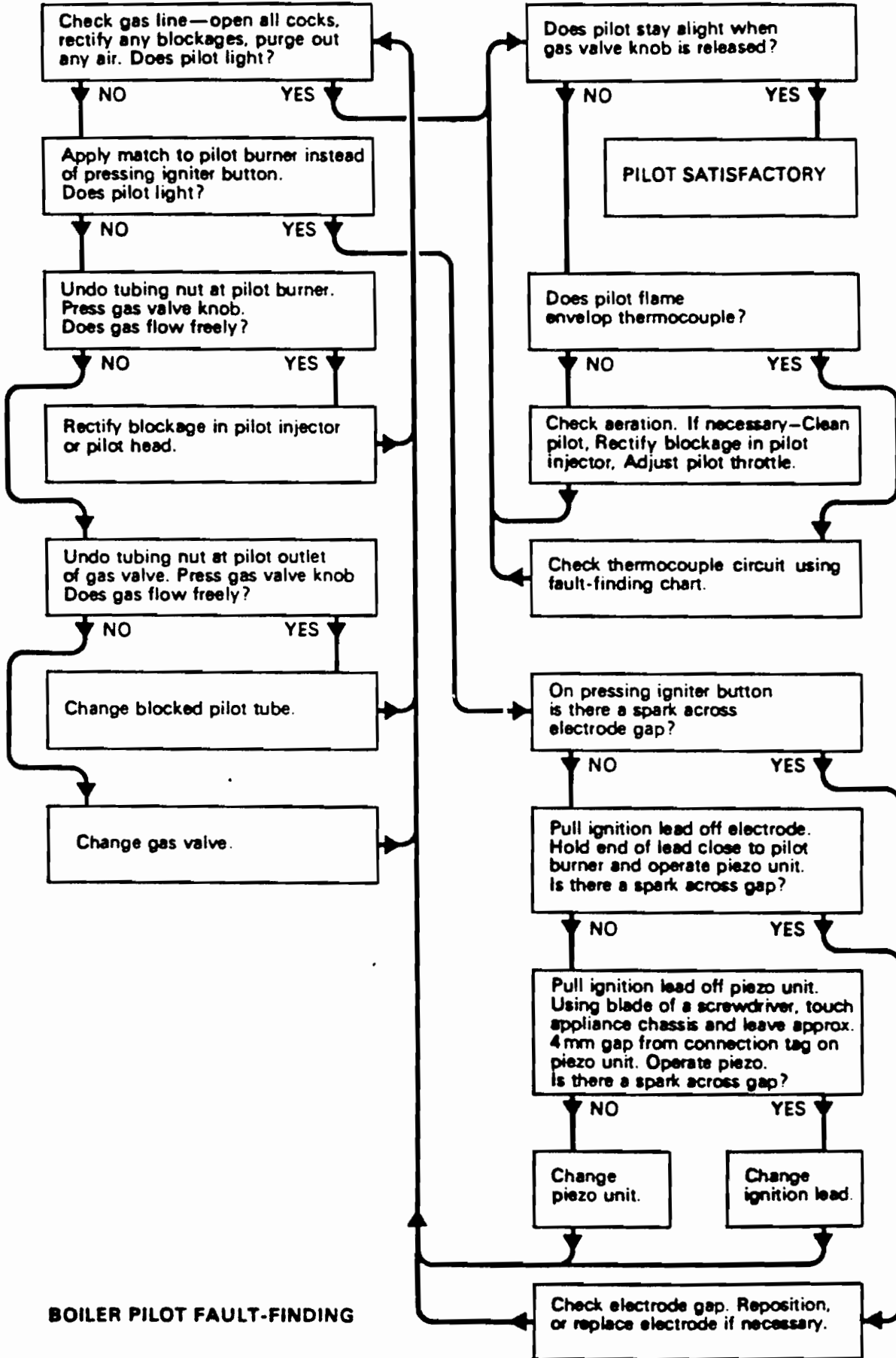

BOILER PILOT FAULT-FINDING

307

12 FAULT FINDING—THERMOCOUPLE

12.1 To test the thermocouple, a meter with a range of 0 to 30mV is required, together with a thermocouple interruptor test unit similar to the British Gas (Minitest 6) Multimeter and interrupter.

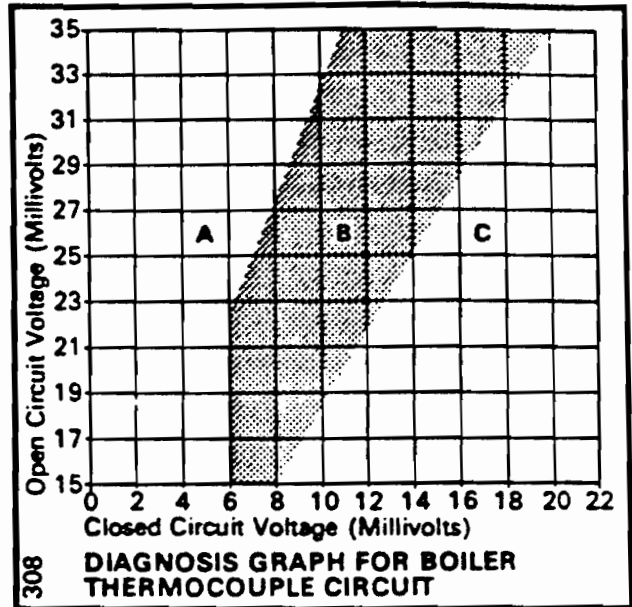

THERMOCOUPLE FAULT FINDING CHART

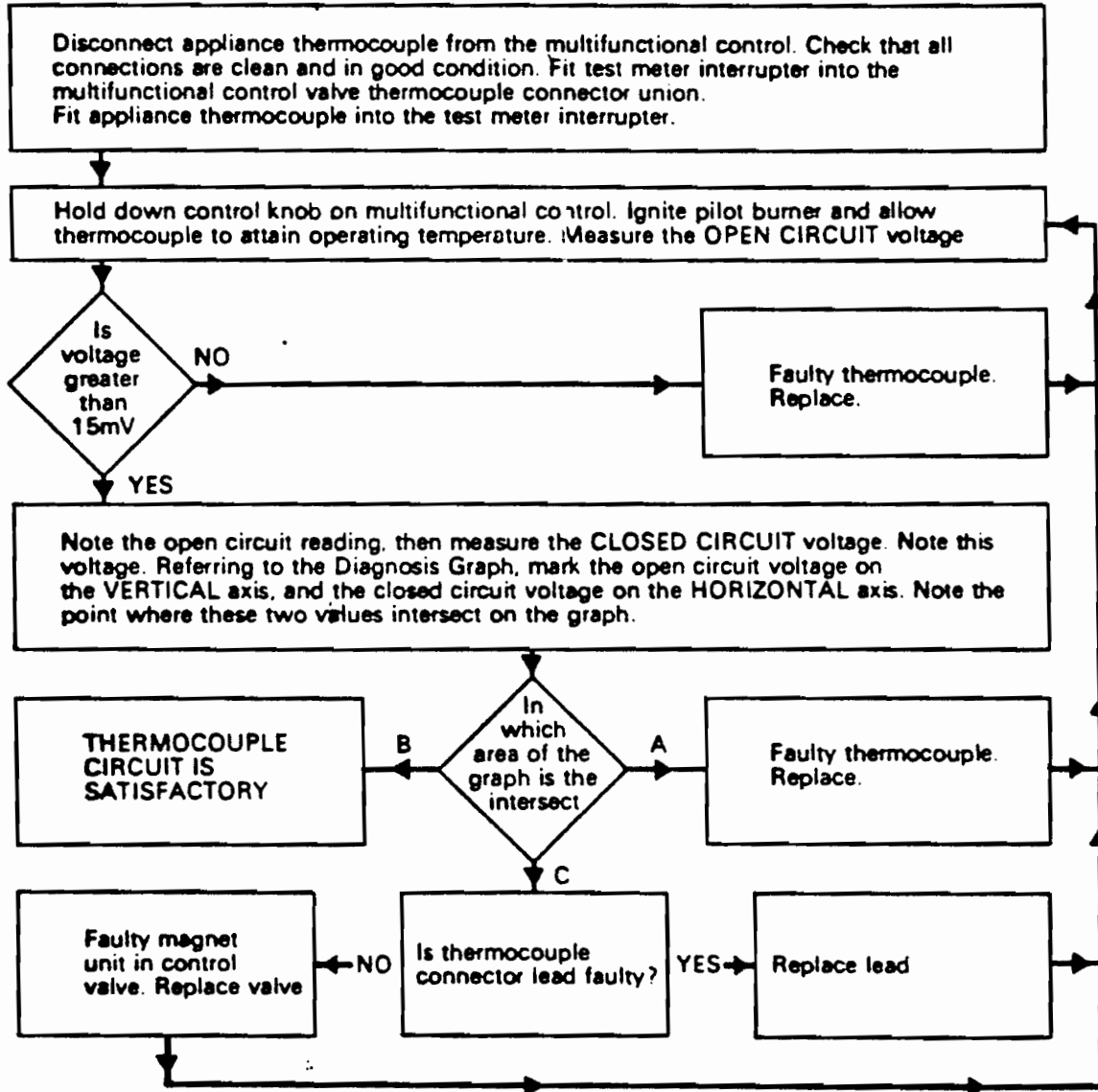

672

12.2 ELECTRICAL FAULT FINDING. Refer to wiring diagram when using this chart below and diagram 22.

12.2.1 IMPORTANT:- The preliminary electrical system checks as contained in the British Gas Multimeter Instructions book are the first checks

to be carried out during a fault-finding procedure. On completion of any fault-finding task which has required the breaking and re-making of electrical connections then the checks 'A' Earth continuity, 'C' Polarity, 'D' Resistance to Earth must be repeated.

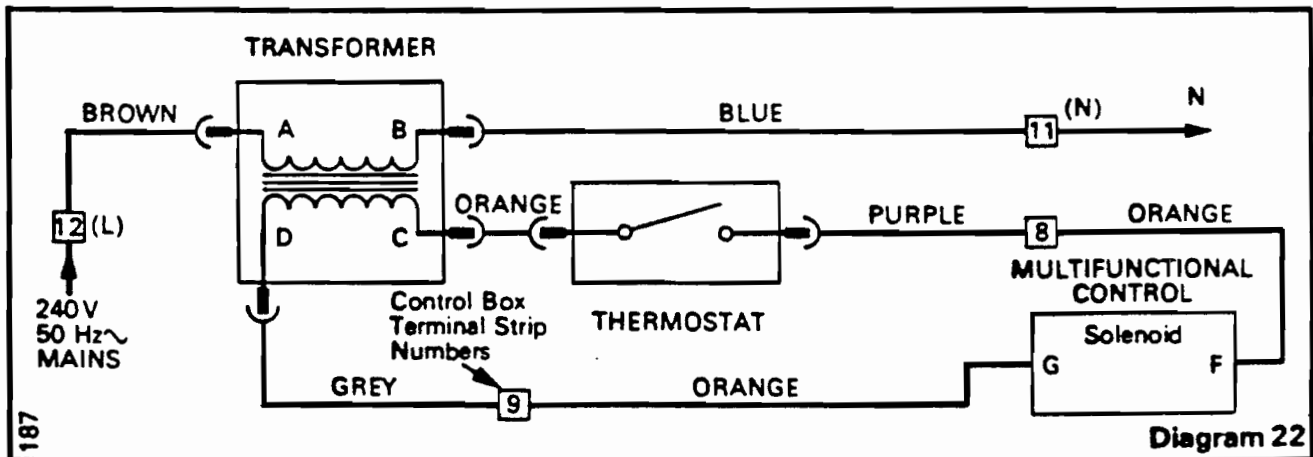
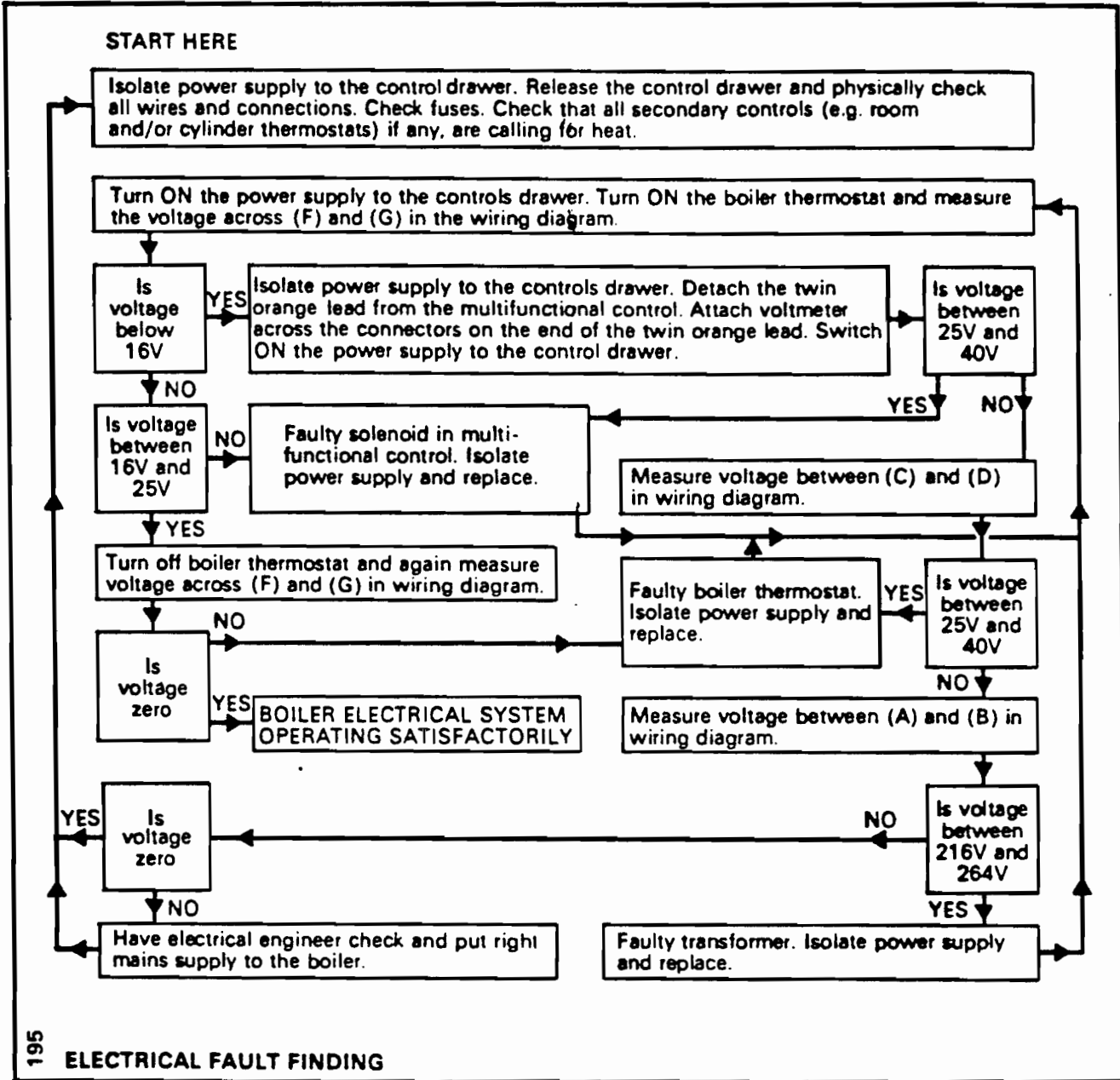

13 REPLACEMENT PARTS

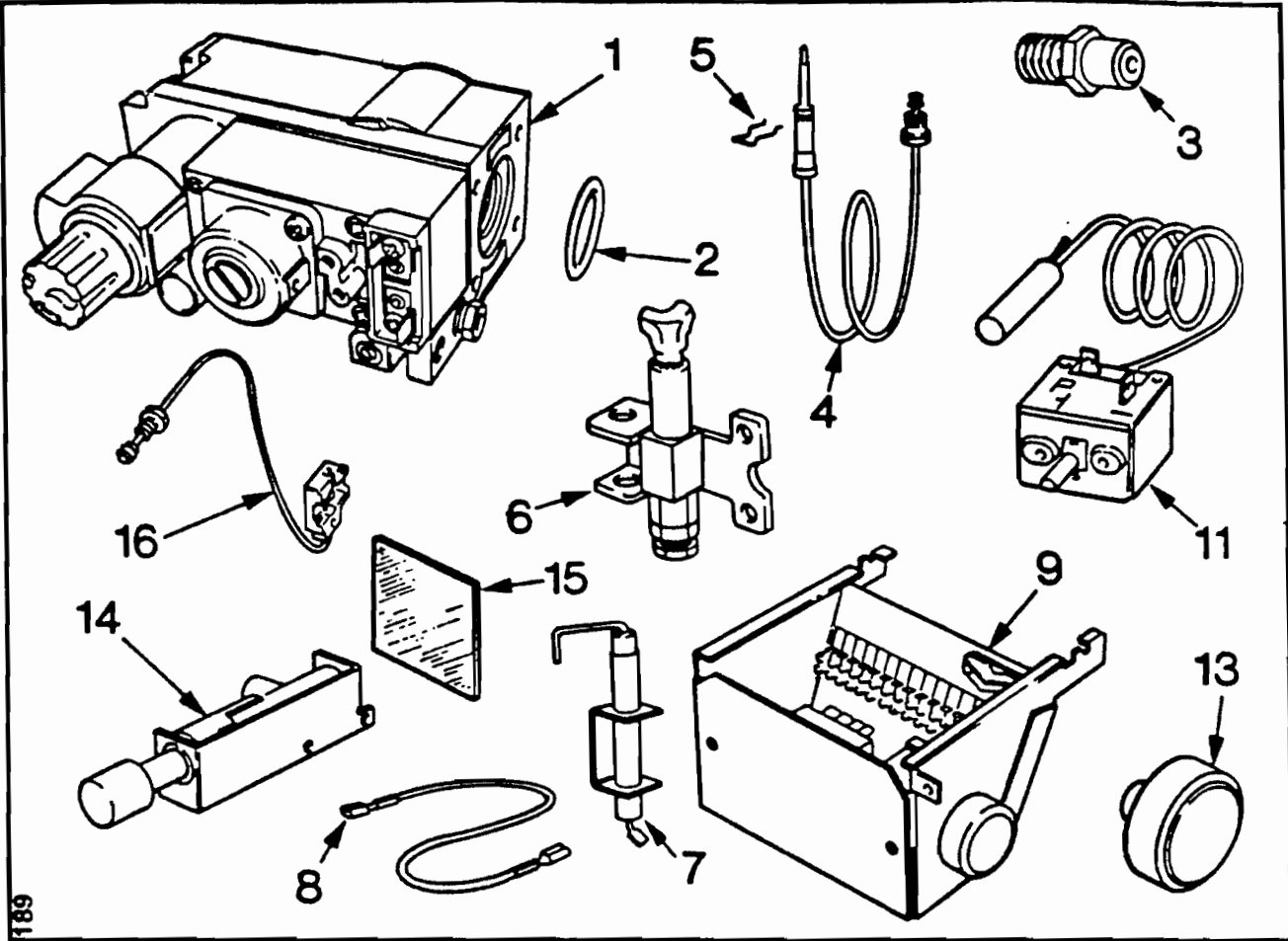

189

Key No.	Glow-worm Part No.	Description	G.C. Part No.
1	203310	Gas valve - Honeywell, R $\frac{1}{2}$	392 693
2	208068	'O' Ring	334 658
3	203001	Injector - marked 203001	355 159
4	K2674	Thermocouple - Maclaren 2500M-36	390 894
5	K3580	Clip for thermocouple	390 983
6	203416	Pilot burner - Johnson, c/w injector	381 793
7	900500	Spark electrode	-
8	WW5101	Ignition lead	355 163
9	409750	Electrical control drawer - Basic	355 485
11	202503	Thermostat - Ranco	395 704
13	FF2228	Control knob assembly - thermostat	351 828
14	K6587	Piezo unit - Kigass	387 907
14	K6587	Piezo unit - Vernitron	393 563
15	411194	Sight window	355 153
16	202403	Thermocouple connector lead	334 689

} Alternatives

If replacement parts are required, apply to your local supplier. Please quote the name Space Saver 60B MkII and the serial number from the data badge, which can be found at the top right corner of the main panel.

Glow-worm Ltd
 Nottingham Road, Belper, Derby DE5 1JT
 Telephone Belper (077 382) 4141
 Telex 37586

719

Because of our constant endeavour for improvement, details may vary slightly from those quoted in these instructions.