

Installation and Operation Instructions for

Mighty Therm

Model HH

Sizes 2000-5000

Hydronic Boilers

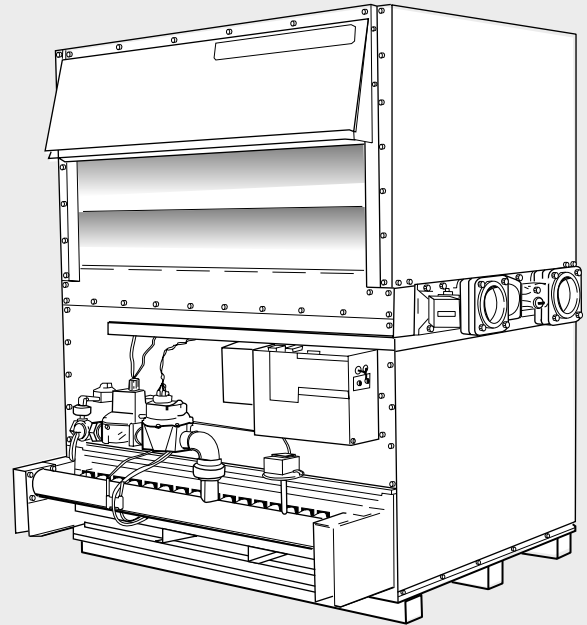
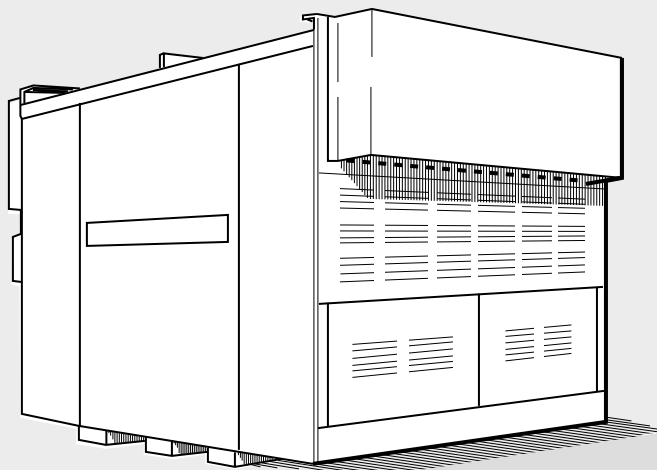

FOR YOUR SAFETY: This product must be installed and serviced by a professional service technician, qualified in hot water heater installation and maintenance. Improper installation and/or operation could create carbon monoxide gas in flue gases which could cause serious injury, property damage, or death. Improper installation and/or operation will void the warranty.

⚠ WARNING

If the information in this manual is not followed exactly, a fire or explosion may result causing property damage, personal injury or loss of life.

Do not store or use gasoline or other flammable vapors and liquids in the vicinity of this or any other appliance.

WHAT TO DO IF YOU SMELL GAS

- Do not try to light any appliance.
- Do not touch any electrical switch; do not use any phone in your building.
- Immediately call your gas supplier from a nearby phone. Follow the gas supplier's instructions.
- If you cannot reach your gas supplier, call the fire department.

Installation and service must be performed by a qualified installer, service agency, or gas supplier.

TABLE OF CONTENTS

SECTION 1.

General Information

1A.	Introduction	3
1B.	Flow Requirements	4
1C.	Variable Water Flow Systems	4
1C-1.	A Special Note About 3-Way Water Valves	5
1C-2.	System Pressure Requirements	5
1D.	Warning Regarding Chilled Water Systems	5

SECTION 2.

Installation

2A.	Boiler Placement	5
2B.	Installation of Indoor Boilers	6
2B-1.	Combustion Air Supply	6
2B-2.	Venting	7
2C.	Installation of Outdoor Heater	7
2D.	Freeze Protection	8
2E.	Gas Supply and Piping	8
2F.	Electrical Wiring	9
2G.	Piping of System to Boiler	9
2H.	Filling Fully-Connected System	10

SECTION 3.

Operation

3A.	Initial Start Up	10
3B.	To Start Up System	11

3C.	To Turn Off Boiler	12
3D.	To Shut Down System	12

SECTION 4.

Maintenance

.....	12
-------	----

SECTION 5.

Troubleshooting and Analysis of Service Problems

.....	13
-------	----

SECTION 6.

Conversion of VW from Indoor to Outdoor Models

.....	15
-------	----

SECTION 7.

Parts Description and Order Numbers

.....	18
-------	----

SECTION 1. General Information

⚠ IMPORTANT WARNING:

The Model HH hydronic boiler must be installed in accordance with the procedures outlined in this manual. Warranty does not apply to boilers not installed or operated in accordance with these procedures. Consult local building and safety codes before proceeding with work. The installation must conform to the requirements of the authority having jurisdiction or, in the absence of such requirements, to the latest edition of the National Fuel Gas Code, ANSI Z223.1 and/or in Canada, CAN1-B149 requirement.

When required by the authority having jurisdiction, the installation must conform to American Society of Mechanical Engineers safety code for controls and safety devices for automatically fired boilers No. CSD-1, and in Canada, CGA3.3. Any modification to the boiler, its gas controls, gas orifices, wiring or draft diverter may void the Laars warranty. If field conditions require such modifications, consult Factory.

1A. Introduction

This manual provides information for the installation and operation of Laars boilers. It is strongly recommended that all application and installation procedures be reviewed completely before proceeding with the installation. Consult the factory, or local factory representative, with any problems or questions regarding this equipment. Experience has shown that most operating problems are caused by improper installation.

Model HH boilers are offered in two configurations: An indoor version and an outdoor version. The indoor version is convertible for outdoor use with the installation of a conversion kit as described in Section 6 of this manual. The two configurations are shown in Figure 1.

Some accessory items are shipped in separate packages. Verify receipt of all packages listed on the packing slip. Inspect everything for damage immediately upon delivery, and advise the carrier of any shortages or damage. Any such claims should be filed with the carrier. The carrier, not the shipper, is responsible for shortages and damage to the shipment whether visible or concealed.

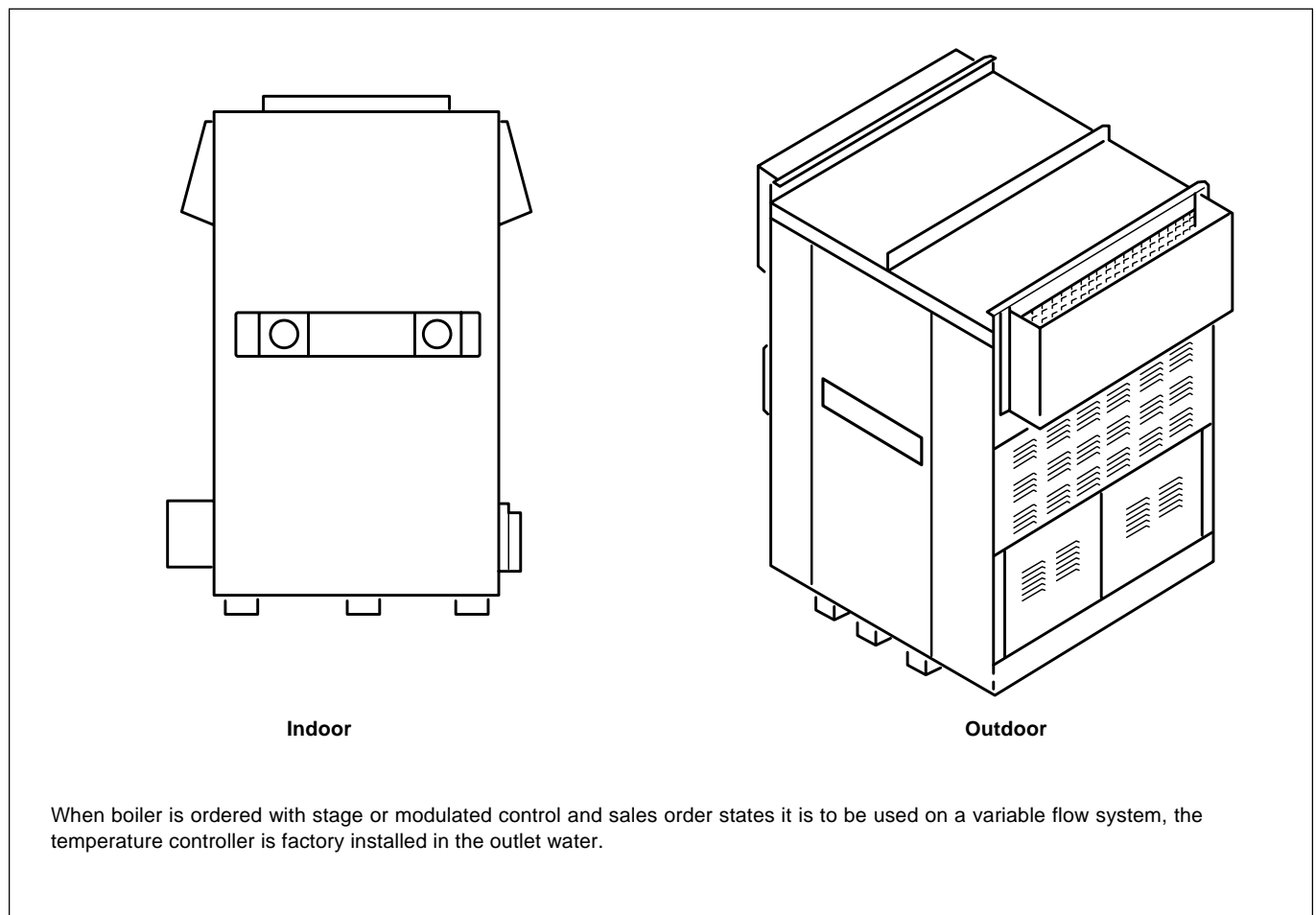

Figure 1. Boiler Configuration.

1B. Flow Requirements

All low volume hydronic boilers must have continuous flow through the heat exchanger when firing, for proper operation. The system pump must be capable of developing sufficient pressure to overcome the resistance of the boiler plus the entire circulating system at the designated GPM (see Table 1). The temperature rise across the boiler should never exceed 40° F.

NOTE: Water entering boiler should be 105°F minimum.

1C. Variable Water Flow Systems

Heating systems using zone valves, zone pumps or 3-way valves can experience reduced water flow through the boiler. This can result in an excessive water temperature rise and unstable boiler operation. If system water flow is variable, it must not be allowed to fall below 30% of full flow. The boiler must be equipped with staged or modulated fire with the temperature sensor installed in the outlet water. State variable flow when ordering. Laars recommends primary-secondary pumping for all variable flow systems. Primary-secondary pumping is mandatory for variable flow systems where minimum flows are less than 30% of full flow conditions. The boiler pump in a primary-secondary system maintains constant flow through the boiler even though the system flow is variable. In a primary-secondary system the pressure drop of the boiler is not added to the system (see Figure 2).

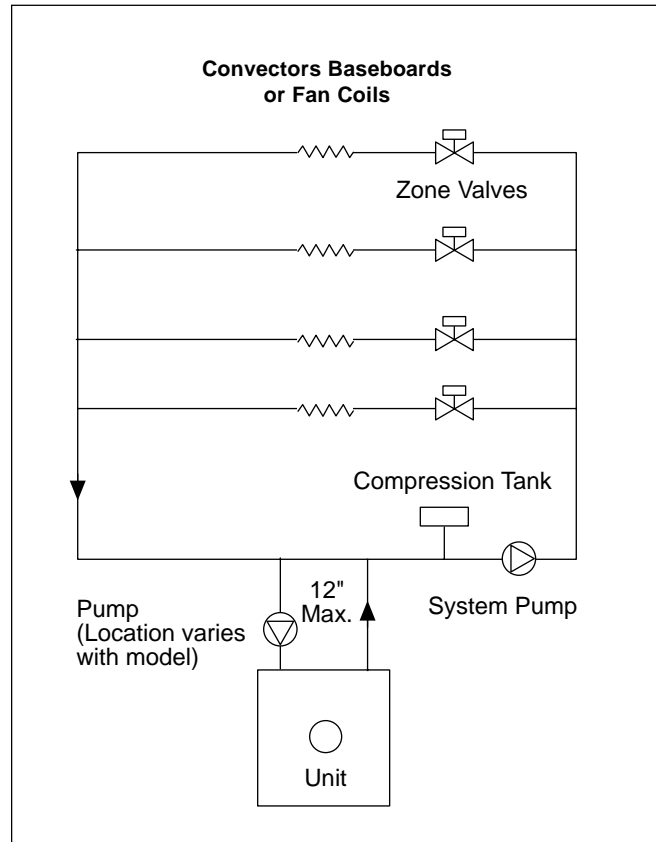

Figure 2. Primary-Secondary System.

		20°F		25°F		30°F		35°F	
Size (I)	Size (E)	GPM	H/L	GPM	H/L	GPM	H/L	GPM	H/L
20001P	-----	164	3.91	131	3.6	109	1.8	94	0.7
2P	-----	164	10.5	131	7.4	109	4.9	94	3.0
24501P	22001P	201	5.9	161	3.9	134	3.8	115	2.3
2P	2P	201	16.4	161	10.2	134	7.7	115	5.7
30501P	28001P	250	9.3	200	5.9	167	4.5	143	3.8
2P	2P	*	*	200	16.4	167	12.5	143	8.5
35001P	32001P	284	12.0	230	8.7	189	5.7	164	3.9
2P	1P	*	*	*	*	189	16.8	164	10.5
40501P	36001P	332	17.2	266	11.9	222	8.1	190	5.8
2P	2P	*	*	*	*	222	24.0	190	16.0
45001P	40001P	369	21.75	295	13.2	246	10.0	211	7.0
2P	2P	*	*	*	*	*	*	211	20.0
50001P	45001P	410	27.0	328	16.8	273	13.0	234	9.0
2P	2P	*	*	*	*	*	*	*	*
		HIGH		NORMAL				LOW	

* Not recommended, consult factory.

I=Indoor, E=Outdoor. GPM=Water flow. H/H=Pressure drop (head loss)through the boiler, expressed in Ft. of H₂O. 1P=Single-pass heat exchanger. 2P=Two-pass heat exchanger. Shaded area is the recommended flow and temperature rise.

Table 1. Water Flow, Temperature Rise and Pressure Drop.

1C-1. A Special Note About 3-Way Water Valves

3-way water valves (2 position or proportional) are sometimes used to divert water around a boiler and control the temperature of water being supplied to the system. Valves installed in this manner must be supplied with an end switch or some other suitable control to shut off the boiler when the flow is reduced to 30%. The boiler must be supplied with staged or modulated fire as indicated in Section 1C, Variable Water Flow Systems.

It is often possible to accomplish excellent water temperature control without 3-way valves through proper application of staged or modulated firing systems. Consult the factory or local Laars representative for assistance with such systems.

1C-2. System Pressure Requirements

The Model HH boilers are designed to operate on closed, pressurized systems. A minimum of 12 psi should be maintained on the system where boiler supply water temperatures are 200°F or less. If higher temperatures are required, the minimum system pressure should be at least 15 psi above the water vapor pressure corresponding to the elevated water temperature.

The Model HH boilers are not suitable for open systems unless the supply water temperatures are kept below 180°F, and a minimum of 5 psi static head is maintained at the boiler.

1D. Warning Regarding Chilled Water Systems

When a boiler is connected to an air conditioning system where the same water is used for heating and cooling, chilled water must be prevented from entering the boiler. When changing such a system from cooling to heating, the chilled water should be allowed to circulate through the building after the chiller has been turned off long enough for the water to warm up to at least 70°F before the water is allowed to flow into the boiler. It is equally important to prevent hot water from entering the chiller. The system shown in Figure 3 is suggested to make sure that the system water is neither too hot nor too cold when a changeover from heating to cooling, or vice versa, takes place. When a boiler is connected to heating coils located in air handling units (where they may be exposed to refrigerated air circulation), the boiler piping system shall be equipped with a flow control valve or other automatic means to prevent gravity circulation of chilled water through the boiler. Chilled water in the boiler will create condensate on the boiler tubes which will drip on the burners and may extinguish the pilot.

Boilers installed in violation of either of the above requirements may void the warranty.

SECTION 2. Installation

2A. Boiler Placement

The boiler must be placed to provide clearances on all sides for maintenance and inspection. There must also be minimum distances maintained from combustible surfaces.

All boilers must be installed on a non-combustible floor. Under no circumstances can boilers be installed on carpeting.

The National Fuel Code allows a boiler to be placed on a combustible surface when such an installation complies with the local codes. This code specifies the surface under the boiler be protected with hollow masonry no less than 4" thick, covered with sheet metal at least 20 Ga. in thickness. Such masonry

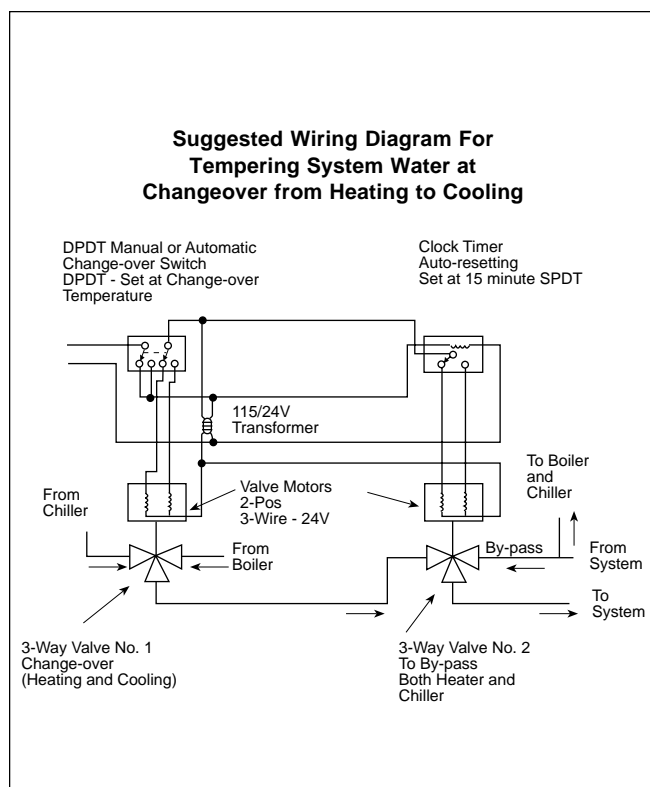

Figure 3. Boiler-Chiller Installation.

Clearance From	Indoor (Inches)	Outdoor (Inches)
Top	24	—
Water Connection Side	24	24
Opposite Side	24	24
Front	48	48
Rear	24	24
Vent	6	—

Table 2. Minimum Clearances from Combustible Surfaces.

must be laid with ends unsealed, and joints matched in such a way as to provide a free circulation of air from side to side through the masonry (see Figure 4).

2B. Installation of Indoor Boilers
2B-1. Combustion Air Supply

1. The boiler location must provide sufficient air supply for proper combustion, and ventilation of the surrounding area as outlined in the latest edition of ANSI standard Z223.1, and/or in Canada CAN1-B149 requirement, and any local codes that may be applicable. Inadequate combustion air supply may result in incomplete combustion and consequent sooting of the heat exchanger and unsafe operation of the boiler.
2. In general, in the U.S., these requirements specify that boiler rooms, which represent confined spaces, should be provided with two permanent air supply openings communicating directly through the wall to outside air; one within 12 inches of the ceiling, the other within 12 inches of the floor. Each opening should have a minimum free area of one square inch per 4,000 BTUs/H input rating of all appliances in the enclosed area. See Table 3 for recommended air supply for each model. An improperly ventilated equipment room can get excessively hot and cause accelerated deterioration of controls and electrical components.

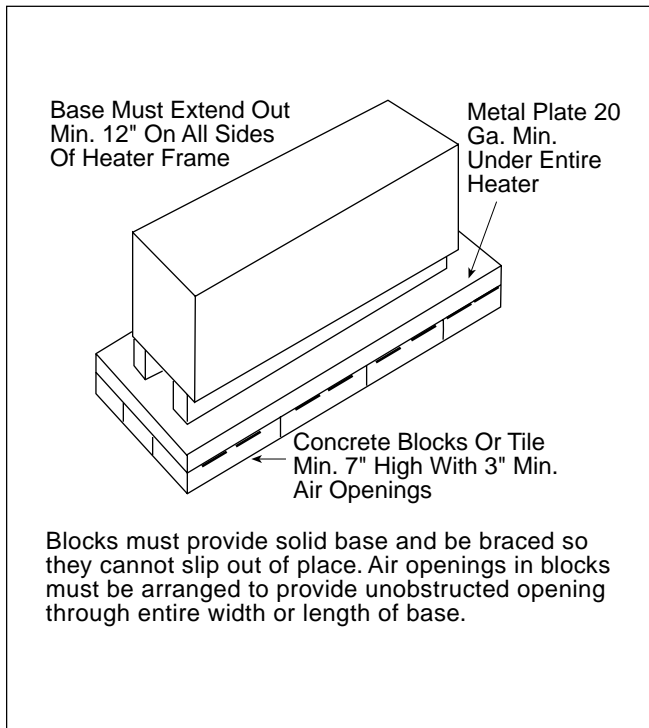

Figure 4. Non-combustible Base.

NOTE: In Canada (Table 3 does not apply) consult local building and safety codes or, in the absence of such requirements, follow CGA requirement, and/or CAN1-B149 standard.

3. Exhaust Fans or Vents: Any equipment which exhausts air from the boiler room can deplete the combustion air supply or reverse the natural draft action of the venting system. This could cause flue products to accumulate in the boiler room. Additional air must be supplied to compensate for such exhaust. The information in **Table 3** is not applicable in installations where exhaust fans or blowers of any type are used. Such installations must be designed by qualified engineers.
4. If a blower or fan is used to supply air to the boiler room, the installer should make sure it does not create drafts which could cause nuisance shutdowns of the pilot. If a blower is necessary to provide adequate combustion air to the boiler, a suitable switch or equivalent must be wired into the boiler control circuit to prevent the boiler from firing unless the blower is operating.
5. The boiler must be completely isolated and protected from any source of corrosive chemical fumes such as emitted by trichlorethylene, perchlorethylene, chlorine, etc.

Indoor Size	Each Opening* (Square Inches)
2000	500
2450	613
3050	763
3500	875
4050	1013
4500	1125
5000	1250
Net Free Area in Square Inches*	

*Area indicated is for one of two openings; one at floor level and one at the ceiling, so the total net free area would be double the figures indicated. For all other conditions, refer to latest edition of ANSI Bulletin Z223.1.

NOTE: Check with louver manufacturers for Net Free Area of louvers. Correct for screen resistance to the Net Free Area if a screen is installed. Check all local codes applicable to combustion air.

Table 3. Minimum Recommended Air Supply To Boiler Room.

2B-2. Venting

1. Laars boilers have built-in draft diverters for natural draft operation and must not be connected into any portion of a mechanical draft system under positive pressure. The flue outlet must be connected to a clear, unobstructed vent of adequate capacity terminating above the highest point of the building with an approved vent cap. The venting system should be installed according to the latest edition of ANSI Z223.1 and any local codes having jurisdiction and/or in Canada follow CAN1-B149 standard.

IMPORTANT NOTE: Do not use sheet metal screws at the snap lock joints of Type B gas vents.

2. Do not weld or fasten the vent pipe to the boiler draft hood. The weight of the stack must not rest on the boiler. The draft hood and boiler top must be easily removable for normal boiler service and inspection.
3. Avoid long horizontal runs of the vent pipe, and too many 90° elbows, reductions and restrictions. Horizontal runs should have at least a ¼" rise per foot in the direction of flow. A vent connector shall be supported for the design and weight of the material employed to maintain clearances and prevent physical damage and separation of joints.
4. Avoid terminating boiler vents near air conditioning or air supply fans. The fans can pick up exhaust flue products from the boiler and return them inside the building, creating a possible health hazard. A minimum of 4 feet horizontal distance must be maintained from electric meters, gas meters, and relief equipment.

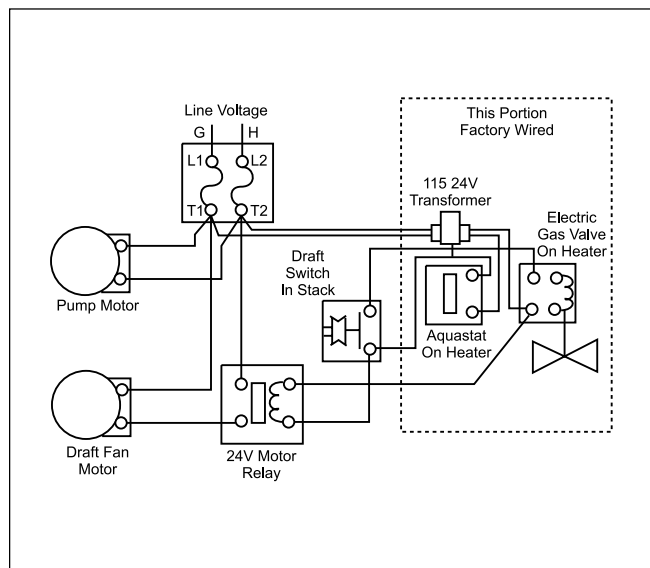

Figure 7. Method of Installing a Tee Sediment Trap.

5. Always use double-wall or insulated vent pipe (Type B or equivalent). In cold weather, uninsulated outside vents can chill the rising flue products, blocking the natural draft action of the venting system. This can create a health hazard by spilling flue products into the boiler room.
6. Avoid oversize vent piping or extremely long runs of the pipe which may cause excessive cooling and condensation. Rule of Thumb: The total length of the vent, including the connector and any offset, should not exceed 15 feet for every inch of vent diameter. Longer total lengths shown in venting tables are based on maximum capacity, not condensation factors.
7. When the installation of a draft fan is necessary in the venting system to which a Laars boiler is to be connected, the installation should be engineered by competent personnel following good engineering practices. The draft fan supplier should be consulted for correct size. The installation should be in accordance with the latest edition of ANSI Z223.1 and any local codes having jurisdiction, in Canada follow CAN1-B149 standard. When a draft fan is installed, a suitable draft switch must be used and wired into the boiler control circuit at terminal designated "Field Interlock," to prevent firing of the boiler unless a positive draft has been established (see Figure 5).

2C. Installation of Outdoor Boilers

⚠ Caution

Outdoor installations are not recommended in areas where the danger of snow blockage exists.

1. Locate the boiler to provide the minimum clearances as listed in Section 2A, "Placement of Boiler."
2. Do not locate the boiler in an enclosure or wall recess. Avoid location where wind deflection off structures might cause down draft. When such

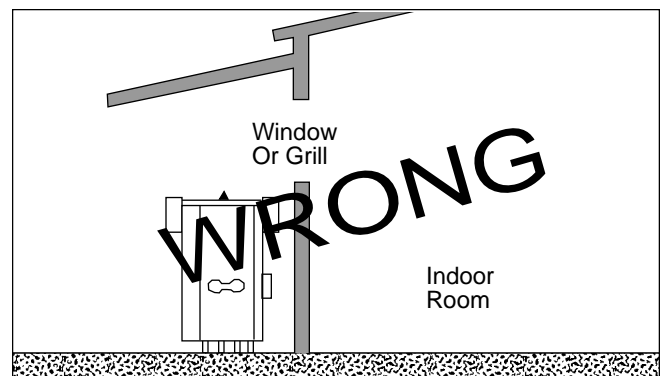

Figure 6. Incorrect Outdoor Installation of Boiler.

- wind conditions are possible, locate the boiler at least three (3) feet from the structures.
- Never install the boiler under any kind of roof overhang. Do not locate the boiler below or adjacent to any doors, windows, louvers, grills, etc. which communicate in any way with an inhabited area of a building. Even though such communication might be through another structure such as a garage or utility room (see Figure 6).

2D. Freeze Protection

Boiler installations are not recommended in areas where the danger of freezing exists unless proper precautions are made for freeze protection. Maintaining a mixture of 50% water and 50% ethylene glycol is the preferred method of freeze protection for hydronic systems. This mixture will protect the boiler to temperatures of about -35°F. To get the desired temperature rise across the boiler when this mixture is used, increase the G.P.M. flow recommended for water by 15%. Increase the head loss requirement by 20%.

2E. Gas Supply and Piping

Review the following instructions before proceeding with the installation.

- Verify that the boiler is fitted for the proper type of gas by checking the rating plate. Laars boilers are normally equipped to operate below a 2000 foot altitude. Boilers equipped to operate at higher altitudes have appropriate stickers or tags attached.
- Use the figures in Table 4 to provide adequate gas piping (check local code for BTU capacity required).
- A trap (drip leg) must be provided ahead of the gas controls (see Figure 7). Where required by code, provide a second manual gas shutoff valve. Do not remove manual valve furnished with the boiler.

- The boiler and its individual shutoff valve must be disconnected from the gas supply piping system during any pressure testing of that system at test pressures in excess of ½ psig. The boiler must be isolated from the gas supply piping system by closing its individual manual gas shutoff valve during any pressure testing of the gas supply piping system at test pressures equal to or less than ½ psig.
- Provide gas supply pressure to the boiler as follows:

	Natural Gas	LPG
Min. (inches water column)	7	11
Max.(inches water column)	9	14

Note: The boiler and all other gas appliances sharing the boiler gas supply line must be firing at maximum capacity to properly measure the inlet supply pressure. Low gas pressure could be an indication of an undersize gas meter and/or obstructed gas supply line.

- The correct burner manifold gas pressure is stamped on the rating plate. The regulator is pre-set at the factory, and normally requires no further adjustment.
- The gas manifold and control assembly was tested and conform to the safe lighting and other performance criteria specified in the latest editions of ANSI Z21.13 and CGA 3.3 Low Pressure Boiler Standard.

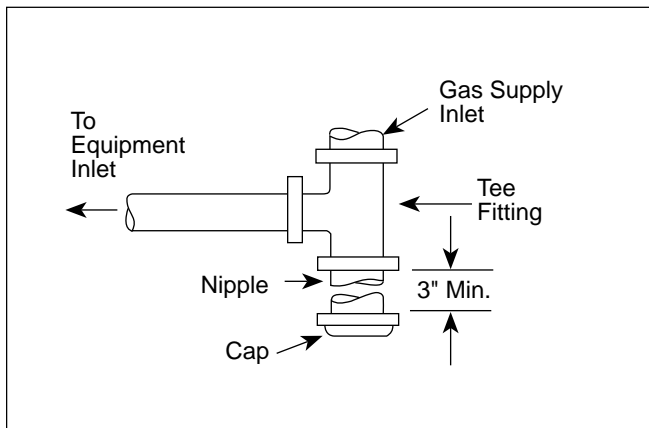

Figure 7. Method of Installing a Tee Sediment Trap.

		Distance from Gas Meter or Last Stage Regulator					
Indoor Size	Outdoor Size	0-100'		100-200'		200-300'	
		Nat.	Pro.	Nat.	Pro.	Nat.	Pro.
2000	-----	2½	2	3	2½	3	3
2450	2200	3	2½	3	2½	3½	3
3050	2800	3	2½	3½	3	3½	3
3500	3200	3	2½	3½	3	4	3½
4050	3600	3½	3	4	3½	4	3½
4500	4000	3½	3	4	3½	5	4
5000	4500	4	3½	4	3½	5	4

NOTES:
 These figures are based on 1/2" water column pressure drop.
 Check supply pressure and local code requirements before proceeding with work.
 Pipe fittings must be considered when determining gas pipe sizing.

8. Before operating the boiler, the complete gas supply system and all connections must be tested for leaks using a soap solution. **Do not use raw flame.**

⚠ Caution

Since some leak test solutions, including soap and water, may cause corrosion or stress cracking, the piping must be rinsed with water after testing, unless it has been determined that the leak test solution is noncorrosive.

Arrangement of gas train components for on-off, 2-stage and 4-stage firing are shown schematically in the Gas Piping Diagram (see Figure 8).

2F. Electrical Wiring

(electrical diagrams are included with the packet provided with each unit)

⚠ WARNING

The boiler must be electrically grounded in accordance with the most recent edition of the National Electrical Code, ANSI/NFPA 70 and, in Canada, follow Canadian Electrical Code CSA C22.1. Do not rely on the gas or water piping to ground the metal parts of the boiler. Many times, plastic pipe or dielectric unions isolate the boiler electrically. Service and maintenance personnel who work on or around the boiler may be standing on wet floors and could be electrocuted by a poorly grounded boiler.

1. Check boiler wiring and pump for correct voltage, frequency and phase. If the pump circuit is other than 115V, check to see that the boiler is provided with an appropriate transformer.
2. Wire the boiler and pump exactly as shown in the wiring diagram supplied with the boiler.
3. The pump and boiler must be electrically interlocked so the boiler cannot come on unless the pump is running.
4. All field installed electrical safety devices and all field installed devices (draft switches, relays, timers, outdoor temperature reset devices, etc.) can be connected to the boiler wiring at points shown in the wiring diagram designated "Field Interlock."

2G. Piping of System to Boiler

1. Be sure to provide gate valves at the inlet and outlet to the boiler so it can be readily isolated for service.
2. The pressure relief valve must be installed in the tapped opening provided in the boiler header with its outlet piped to a drain or floor sink. Special attention must be given to relief valve settings in installations where the boiler is located on the ground floor of a tall building, or where the operating temperature of the boiler is above 210°F. In both instances, the static pressure of the system is elevated, and could cause the relief valve to leak and bring considerable raw water into the system. Where no special setting of the relief valve is ordered, the factory will furnish a 125 psi setting. Never reduce the relief valve opening. If necessary, install the relief valve in a Tee immediately past the boiler outlet.
3. A boiler installed above radiation level must be provided with a low water cutoff device either as part of the boiler or at the time of boiler installation (see Figure 9).
4. Install manual and/or automatic bleeding devices at high points in the system to eliminate air. Install a correctly sized expansion or compression tank with suitable air charger and tank drainer, as appropriate.
5. The weight of all water and gas piping should be supported by suitable hangers or floor stands.
6. Check piping diagrams with local applicable plumbing, heating and building safety codes.

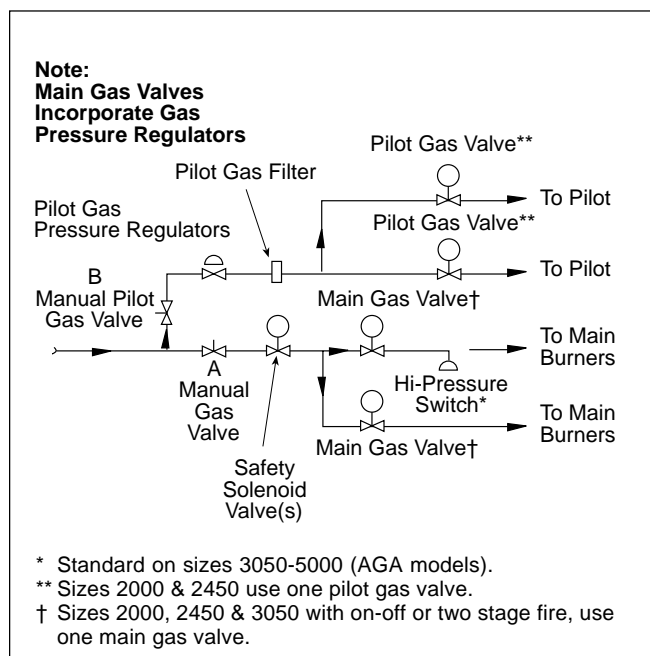

2H. Filling Fully-Connected System

1. Close all bleeding devices and open make-up water valve. Allow system to fill slowly.
2. If make-up water pump is employed, adjust pressure switch on pumping system to provide a minimum of 12 psi at the highest point in the heating loop.
3. If a water pressure regulator is provided on the make-up water line, adjust the pressure regulator to provide at least 12 psi at the highest point in the heating loop.
4. Open bleeding devices on all radiation units at the high points in the piping throughout the system, unless automatic air bleeders are provided at such points.
5. Run system circulating pump for a minimum of 30 minutes with the boiler shut off.
6. Open all strainers in the circulating system and check for debris.
7. Recheck all air bleeders as described in Step 4.
8. Check liquid level in expansion tank. With the system full of water and under normal operating pressure, the level of water in the expansion tank should not exceed $\frac{1}{4}$ of the total, with the balance filled with air.
9. Start up boiler according to procedure described in Section 3A. Operate the entire system, including the pump, boiler, and radiation units for one (1) hour.
10. Recheck the water level in the expansion tank. If the water level exceeds $\frac{1}{4}$ of the volume of the expansion tank, open the tank drainer and drain to that level.
11. Shut down the entire system and vent all radiation units and high points in the system piping as described in Step 4.
12. Close make-up water valve and check strainer in pressure reducing valve for sediment or debris from the make-up water line. Reopen make-up water valve.
13. Check gauge for correct water pressure and also check water level in the system. If the height indicated above the boiler insures that water is at the highest point in the circulating loop, then the system is ready for operation.
14. Within three (3) days of start-up, recheck all air bleeders and expansion tank as described in Steps 4 and 8.

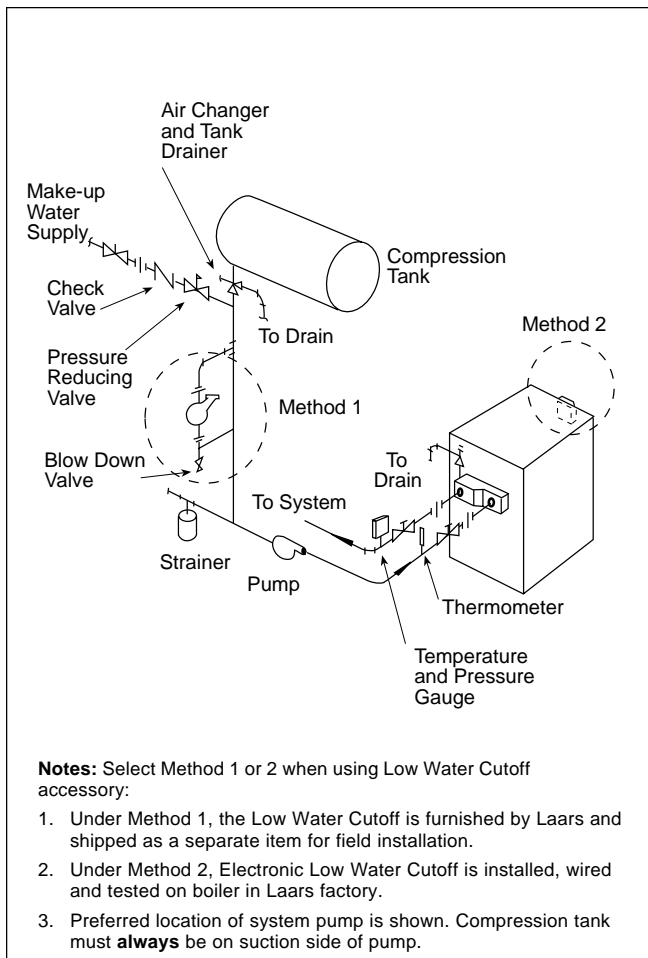

Figure 9. Boiler Piping.

SECTION 3. Operation

3A. Initial Start Up

Lighting: Safe lighting and other performance criteria were met with the gas manifold and control assembly provided on the boiler when it underwent tests specified in the ANSI Z21.13 standard.

Before placing the boiler in operation, the automatic safety shutoff devices must be checked. Once the boiler is connected to the gas piping and after all of the requirements in Section 2 have been met, follow this procedure:

1. Before beginning the tests, make sure the main manual gas valve, and any other boiler firing valves, are in the OFF position.
2. Make sure the power switch on the boiler is in the "ON" position. After placing the manual pilot valves in the open position, and resetting all safety devices (high limit, pressure switch, low water cutoff, etc.), pilots can be lit following the procedure located on the boiler rating plate.

3. Once the pilots are lit and have been established for five minutes, the flame failure response time should be checked as follows:

System 16: (Electronically supervised standing pilot system standard on propane gas) Extinguish the pilot flame by placing the manual pilot valve in the closed position, and, at the same time, begin recording the time it takes for the output signal from the electronic ignition control to be interrupted. Refer to the electrical drawing supplied with the boiler for wiring details. The signal interruption can be detected either with a test light or a voltmeter. Because the ignition controls are in series, the control just upstream of the gas valves should be tested first. Under no circumstances should the response time exceed 5 seconds.

System 18: (Intermittent ignition supplied only for natural gas) With this system, pilots are automatically lit when the thermostat calls for heat. The pilots are permitted a trial period for ignition, then the system is locked out if it fails to light. To retry ignition, power to the boiler must be momentarily interrupted. After the pilot is initially lit, the trial for ignition time should be checked by turning off pilot gas, and, at the same time, monitoring the time it takes for the audible sparking at the pilot burner to stop. Under no circumstances should the trial for ignition exceed 15 seconds. Because the electronic ignition controls are in series, the control just upstream of the gas valves should be tested first (refer to the electrical drawing supplied with the boiler).

Once the trial for ignition period has been checked, the controls should be reset and the flame failure response time checked by following the procedure given for system 16.

4. With the pilots lit, initial activation of the main burners can be achieved by slowly opening the main manual valve. The result should be a smooth lighting of the main burners.

Hi-Limit Checkout

After running the boiler for a long enough period to bring the water temperature within the range of the hi-limit, slowly back off the high limit setting until the boiler shuts off. The main burners should reignite when the hi-limit is turned back up to its original setting.

The high limit should now be reset and the boiler run until it shuts off automatically on high limit.

Now that all tests of the safety shutoff devices have been completed, refer to Section 3B for the proper settings of temperature controls.

3B. To Start Up System

(See Section 3A for Initial Startup)

1. Start up boiler:

- a. Be certain system pump is running.
- b. Lighting instructions are provided on the boiler rating plate and in the User's Manual and are as follows:

1. Turn off main electrical switch.
2. Turn off all manual gas valves and wait five minutes.
3. Set aquastat or thermostat to lowest setting.
4. Slowly turn manual gas valve to ON.
5. Reset all safety valves (pressure switch and manual reset high limit).
6. Open manual pilot valve. Turn on main electrical switch.
7. Set temperature controller to desired temperature. Pilot will light automatically to ignite main burners whenever the thermostat calls for heat.
8. The low firing rate setting must be equal to or greater than the specified minimum input rating as shown on the appliance rating plate. For example, size 2450 has a specified minimum input of 735,000 BTUs/hr. The unit's input rate must not be below this value (refer to rating plate). Laars boilers use gas valves which are factory set to provide an input on low fire that meet or exceed the specified minimum.

2. Set temperature controls:

Boilers on constant flow will have the temperature controller bulb located in the boiler inlet and the high limit sensing bulb in the boiler outlet.

Boilers on variable flow will have both the temperature control sensing bulb and the high limit sensing bulb located in the boiler outlet.

When boiler is installed on a constant water flow system, set temperature controller at the designed system supply temperature less the temperature drop in the system. Set the high limit switch 30°F above the supply temperature to the system.

When boiler is equipped with staged or modulated

fire and installed on a variable flow system, set temperature controller at the designated system temperature. Set the high limit switch 30°F above the supply temperature to the system.

3C. To Turn Off Boiler

1. Turn off main electrical switch.
2. Close all manual gas valves.

3D. To Shut Down System

To shut down boiler, turn off all manual gas valves and electrical disconnect switch. Whenever danger of freezing exists, shut off water supply and remove drain plug in bottom of front header cover and drain every part of system subject to freezing temperatures.

SECTION 4. Maintenance

1. If a strainer is employed in a pressure reducing valve or in the piping, clean it every six (6) months.
2. At start-up and every six (6) months thereafter, the pilot and main burner flame should be observed for proper performance (see Figure 9 and 10; see attached lighting and shutdown instructions for proper pilot flame pattern). If flame has the appearance of "sooting" tips, check for debris near orifices. Call service technician.
3. Inspect the venting system for obstruction, leakage, and corrosion at least once a year.
4. Keep boiler area clear and free from combustible material, gasoline and other flammable liquids and vapors. Boiler surfaces are hot and could ignite combustible material.

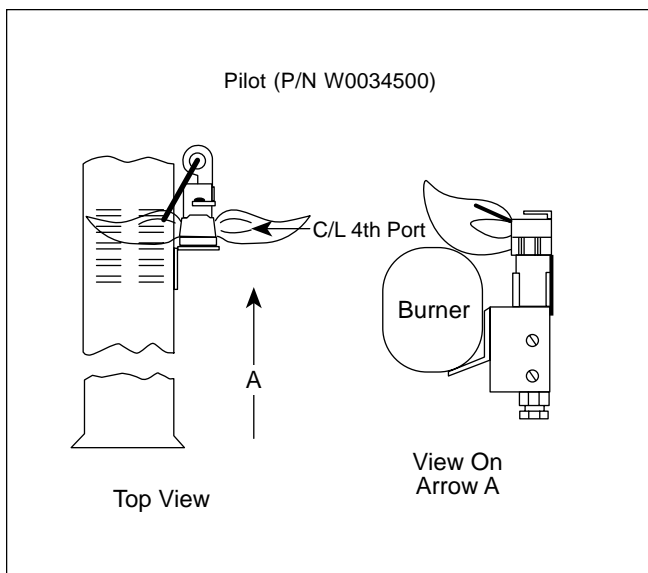

Figure 10. Pilot Location.

5. Be certain all combustion air and ventilation openings are unobstructed.
6. Check for fouling on the external surfaces of the heat exchanger every six months.

NOTE: After installation and first start-up, check the heat exchanger for fouling after the following periods of operation: 24 hours, 7 days, 30 days, 90 days, and once every six months thereafter.

Fouling on the external surfaces of the heat exchanger is caused by incomplete combustion, and is a sign of combustion air and/or venting problems. As soon as any fouling is observed, the cause of the fouling should be corrected (see Section 5 Troubleshooting). The heat exchanger can be checked with a flashlight by locating a mirror under the burners. An alternate method is to remove the venting and top panel as necessary to inspect from above. Also, check the vent system for defects at the same time.

- a. If cleaning is required, shut off all electrical and gas supply to the boiler.
- b. To expose the heat exchanger:

Remove top panel covers located at the base of the front and rear flue collector panels. Remove all but the top screws on each side of the front and rear flue collector panels. The panels can be swung outward and propped up to reveal the heat exchanger. Remove all heat exchanger baffles.

- c. Remove all burners:

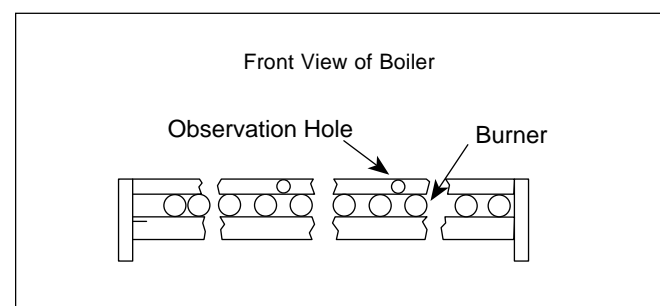
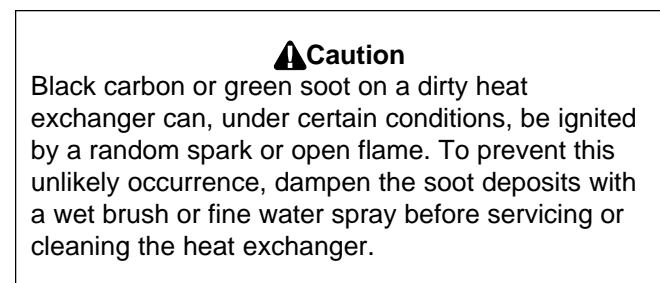

Figure 11. Periodic Flame Observation.

With a wire brush, remove soot and loose scale from the heat exchanger. Do not use water or compressed air for cleaning. Clean fallen debris from the bottom of the boiler. Check that burner ports are clear and pilot assembly is free of debris.

- d. Reassemble in reverse order:
Be sure to replace the heat exchanger baffles.
7. The gas and electric controls installed on the boilers are designed for both dependable operation and long life. But the safety of this equipment depends completely on their proper functioning. It is strongly recommended that the basic items be checked by a competent service technician every year, and replaced when necessary. The basic controls are:
 - a. Water temperature controls.
 - b. Pilot safety system.
 - c. Automatic electric gas valve(s).
 - d. Flow sensing safety device (when used).
 8. Low water cutoffs should be inspected every six (6) months, including flushing or float types.

NOTE: Warranty does not cover any damage caused by lack of required maintenance or improper operating practices.

9. Both modulating and staged valves are adjusted at the factory for minimum permissible rates, and should not be readjusted.

SECTION 5. Troubleshooting and Analysis of Service Problems

1. For proper service and problem diagnosis of the boiler and boiler system, the following tools are required:
 - a. Gas pressure test kit with range from zero to 14" W.C. Either a slack tub manometer or an accurate gas pressure gauge is acceptable with proper adaptors which will connect to the available fittings in the line and on the gas valve.

- b. Electric meter(s) with the following ranges:
0 to 500 volts A.C.
0 to 1000 ohms continuity.
 - c. Millivolt meter with the following ranges:
0 to 50 millivolts.
0 to 500 millivolts.
0 to 1000 millivolts.
 - d. Tube cleaning kit consisting of reamer, stainless steel brush, speed handle and handle extensions.
 - e. Boiler thermometer (with 1/2" NPT well) 100-240°F.
2. In addition, the boiler should be equipped with a system pressure gauge and a thermometer with proper ranges for boiler operation.

3. Boiler will not fire.

Possible Cause	What To Do
A. Electric power is off.	A. Check to see that main power switch is "ON." Use testing device to trace power to heater junction box.
B. Operating or safety control has opened circuit to electric gas valve.	B. Turn off power. Use continuity across terminals of each operating and safety control switch up to the electric gas valve. Replace defective control.
C. Pilot flame is out.	C. Relight pilot per instruction.
D. Manual reset device has tripped.	D. Follow instructions for start-up. Reset pilot safety and all manual reset safety switches and reset manual safety gas valve.
E. No gas pressure to burners.	E. Trace gas line to service shutoff cock. If service cock is open, trace gas line to meter. If no pressure is present at meter, call for public utility service. If gas is present in boiler inlet, check pressures in following sequence: (1) downstream from pressure regulator. (2) downstream from electric gas valve. Replace or adjust as necessary.
F. Electric gas valve operator is burned out or shortened.	F. Disconnect wiring harness at gas valve terminals. Check continuity to actuator coil. If open circuit or short is indicated, replace coil or operator.

4. Boiler is pounding, Knocking or emitting steam from relief valves.

Possible Cause	What To Do
A. Low or no water flow.	A. This condition is usually caused by lack of adequate water flow through boiler. Check the following: 1. Is the heater wired into the pump circuit so that the boiler cannot fire unless the pump is running? 2. Check to see that all valves in system are open to be sure that water can circulate through the boiler and the system. 3. If the system has automatic water valves (2-way or 3-way) that can cut off the water flow through the boiler check to see that they are equipped with end-switches which shut the boiler down when the water flow through the boiler is reduced by 70% from full flow. Also be sure that manual bypasses are provided around two-way zone valves where necessary in order to assure 15% of full flow through the boiler at all times. 4. Examine pump for clogged impeller 5. Water flow through the system may be impeded by air locks at high points. Residual oil in system tends to collect at high points and clog automatic air vents. Be sure that all high points are adequately vented.
B. Low or no system pressure	B. Check for inoperative water makeup valve or pump. Also clean strainer in pressure reducing valve which furnishes makeup water. Look for closed valve in makeup water line or a leak in the system.
C. Clogged "Y" strainer.	C. Remove strainer element and clean screen.
D. Debris from system piping is blocking tubes.	D. Remove header covers. Examine all tubes and waterways. Use new gaskets when reassembling. Clean out tubes.
E. Scale has formed in tubes.	E. This is always caused by the inflow of raw water into the system. Check for leak in system, especially at pump packing. Check for water-logged expansion tank. This condition will cause water to discharge through the relief valve every time the boiler fires and permits raw water to enter the system every time it cools down. Drain expansion tank.

5. Pressure relief valves leaking intermittently or steadily.

Possible Cause	What To Do
A. Static pressure in system exceeds setting of relief valve.	A. Calculate height of water in system above boiler. Install new valve with psi setting 25% above required static system working pressure. Do not exceed 160 psi.
B. Expansion tank is waterlogged.	B. Drain expansion tank, then reopen it to the system. Look for leaks in expansion tank or fittings. Calculate required volume of expansion tank in relation to system to determine that tank is adequate.
C. Valve between system and expansion tank is closed.	C. Open valve so that pressure in system will be open to tank.

6. Soot in flueways or in tubes, or noxious fumes indicative of bad combustion.

Possible Cause	What To Do
A. Combustion air supply to heater room is inadequate.	A. Check air supply opening. Look for debris in screen or louvre which covers combustion air opening, or for material blocking the opening.
B. Stack or vent is blocked or restrictive.	B. Look for blocked stack and excessive number of elbows in stack or excessive length of horizontal runs.
C. Severe down draft is causing spillage of flue products into room.	C. Check for (1) proper vent cap on stack; (2) adequate height of stack above roof; (3) equipment exhausting air from inside of building; and (4) setting on the barometric damper if applicable and (5) proper installation of draft diverter.
D. Gas pressure to burners is excessive.	D. Check gas pressure with manometer, and adjust with heater firing at full rate.
E. Boiler not fitted for the fuel being supplied	E. See nameplate for correct fuel.
F. Boiler installed at high altitude without proper derating.	F. Installations at altitudes in excess of 2000 ft. above sea level are subject to jurisdiction of the local inspection authorities.
G. Water entering boiler is 105°F	G. Add balancing valves if needed to raise entering temperature.

7. Water dripping in firebox.

Possible Cause	What To Do
A. If boiler is used with an air conditioning system, chilled water may be flowing either by gravity or pressure through boiler and creating condensation on boiler tubes.	A. Install flow-check valve or programmed bypass valve in the system for change-over from heating to cooling.
B. Tube in heat exchanger has overheated and ruptured.	B. A tube failure always caused by (a) scale formation in the tube or (b) inadequate water flow through the boiler.

Outdoor Kit Parts List (see Figure 13)

Key No.	Part No.
5	20017100
6	20016900
7	20015101
.....	20015102
8	20016700
9	20017200
10	20017300
11	20017700
12	20016500
13	20016600
14	20016300
15	20014301
.....	20014302
16	20015200
17A Left Front Baffle (Single Inlet Manifold)	20022200
17B Right Front Baffle (Single Inlet Manifold)	20022300
17C Left Front Baffle (Split Inlet Manifold)	20022000
17D Right Front Baffle (Split Inlet Manifold)	20022100
18	20014601
.....	20014602
19	20016100
20	20018000
21	20016200
22	20017200
23	20017600
24	20018200
25	20018300
26	20018600
27	20015001
.....	20015002
28	20016800

SECTION 6.
Conversion of Series HH Boilers
from Indoor to Outdoor Model

Please read the following instructions with Figure 12.

Figure 13 shows the conversion completed.

Please follow the instructions in their numerical order, failure to do this will cause problems on assembly.

1. Remove top panel, (1) (see Figure 12).
2. Remove front and rear upper panels, (2) (see Figure 12).
3. Remove front and rear wings LH & RH, (3) (see Figure 12).
4. Remove diverter assembly, (4) (see Figure 12).
5. Remove outer screw from upper end panel at junction with lower end panel.

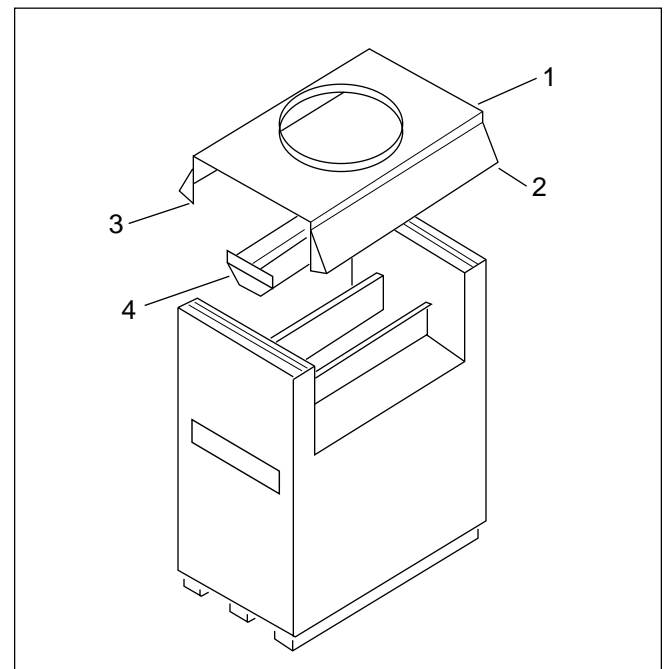

Figure 12. Removal of Indoor Parts.

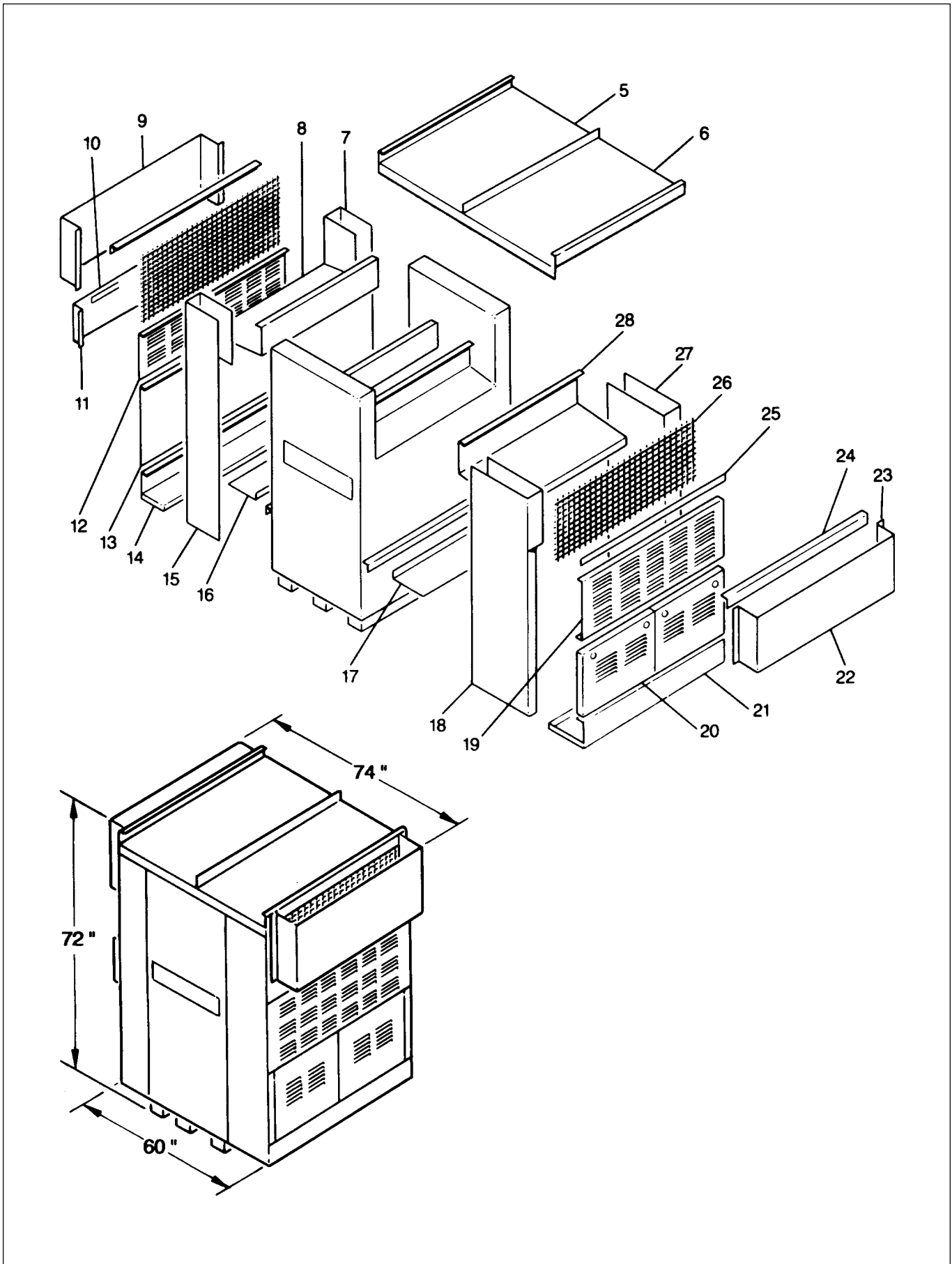

Figure 13. Outdoor Parts Identification.

5. Remove outer screw from upper end panel at junction with lower end panel.
6. Remove and disconnect all probes and wires going to castings and gas train.
7. Remove control box assembly - front of boiler (not shown).

Section 2 (See Figure 13)

1. Install front LH & RH extension panels (flush with top of upper end panel), (18).
2. Install rear LH & RH extension panels (flush with top of upper end panel). (15) (pick up holes provided into LB upper and lower end panels)
3. Install front bottom panel. (21)
4. Install rear bottom panel. (14)
5. Install front inner baffles [2] 4" from ends. (17)
6. Install rear inner baffle [1] 2" from ends. (16)
7. Install front LH & RH upper spacers. (27)
8. Install rear LH & RH upper spacers. (7)
9. Install front flue collector extension (screw onto flange of lower flue collector only). (28)
10. Install rear flue collector extension (screw onto flange of lower flue collector only). (8)
11. Install rear upper panel and remaining screws from flue collector extension. (12)

12. Install middle rear panel. (13)
13. Install front panel making sure opening for removable panel is square. (19)
14. Install front stiffener size 2450 and up.
15. Install remaining screws from flue collector extension.
16. Install rear top half. (5)
17. Install front top half. (6)
18. Install front wire (26) mesh using angle (24) at top and strap (25) at bottom (mesh to be inserted under angles of wind baffle stand offs).
19. Install rear mesh same as Step 18.
20. Install front LH & RH wind baffle stand off. (23)
21. Install rear LH & RH wind baffle stand off. (23)
22. Install front and rear wind baffles. (22)
23. Install middle rear baffle stand off. (11)
24. Install middle rear baffle. (10)
25. Install wires control box parts onto control panel (not shown).
26. Install control panel assembly using holes and bushings provided in RH extension panel for probes and wires (not shown).
27. Install door panels. (20)

SECTION 7.

Parts Description and Order Numbers

Key No.	Description	Size 2000 I	Size 2450 I 2200 E	Size 3050 I 2800 E	Size 3500 I 3200 E	Size 4050 I 3600 E	Size 4500 I 4000 E	Size 5000 I 4500 E
1.	Base Weldment Assembly	20067201	20067202	20067203	20067204	20067205	20067206	20067207
2.	Base Assembly	20011001	20011002	20011003	20011004	20011005	20011006	20011007
3.	Center Heat Shield Assembly	20005701	20005702	20005703	20005704	20005705	20005706 (2)	20005707 (2)
3a.	Center Heat Shield Panel	20005601	20005602	20005603	20005604	20005605	20005606 (2)	20005607 (2)
4.	End Tile Rail Support Assembly (left)	20011101	20011101	20011101	20011101	20011101	20011101	20011101
4a.	End Tile Rail Support Assembly (right)	20011102	20011102	20011102	20011102	20011102	20011102	20011102
5.	Manifold Assy. Single Manifold Assy. Split	20064301 20064302	20064201 20064202	20064401 20064402	20064501 20064502	20064600 20064600	20064700 20064700	20064800 20064800
6a.	Main Burner Assembly Pilot Burner Bracket	20012600	20012600	20012600 (2)	20012600 (2)	20012600 (2)	20012600 (2)	20012600 (2)
6b.	Main Burner (without pilot bracket)	L2005800 (22)	L2005800 (27)	L2005800 (32)	L2005800 (37)	L2005800 (44)	L2005800 (48)	L2005800 (54)
7.	Inner Shield	20002300 (2)	20002300 (2)	20002300 (2)	20002300 (2)	20002300 (2)	20002300 (2)	20002300 (2)
8.	End Tile Channel	20002600 (2)	20002600 (2)	20002600 (2)	20002600 (2)	20002600 (2)	20002600 (2)	20002600 (2)
9.	Front Lower Closure	20004301	20004302	20004303	20004304	20004305	20004306	20004307
10.	Rear Tile Rail Assembly	20011401	20011402	20011403	20011404	20011405	20011406	20011407
11.	Front Tile Rail Assembly	20011301	20011302	20011303	20011304	20011305	20011306	20011307
12.	Rear Closure Assembly	20012401	20012402	20012403	20012404	20012405	20012406	20012407
13.	Heat Shield Support Bracket	20003201 (2)	20003202 (2)	20003203 (2)	20003204 (2)	20003205 (2)	20003206 (2)	20003207 (2)
14.	Tile Heat Shield Assembly	20012101 (2)	20012102 (2)	20012103 (2)	20012104 (2)	20012105 (2)	20012106 (2)	20012107 (2)
15.	Lower Panel Assembly F & R	20011601 (2)	20011602 (2)	20011603 (2)	20011604 (2)	20011605 (2)	20011606 (2)	20011607 (2)
16.	Tile Cover	20005801 (2)	20005802 (2)	20005803 (2)	20005804 (2)	20005805 (2)	20005806 (2)	20005807 (2)
17.	Saddle Assembly End Tile	10533601 (2)	10533601 (2)	10533601 (2)	10533601 (2)	10533601 (2)	10533601 (2)	10533601 (2)
18-19.	Tile Assembly	See Tile Drawing on Page 20						
20.	Center Support Assembly	20004900	20004900	20004900	20004900	20004900	20004900	20004900
21.	Heat Exchanger Assembly	20001301	20001302	20001303	20001304	20001305	20001306	20001307
21a.	Gasket, Header	S0095300	S0095300	S0095300	S0095300	S0095300	S0095300	S0095300
21b.	Water Barrier	10397500	10397500	10397500	10397500	10397500	10397500	10397500
21c.	Double Pass Header	10416200	10416200	10416200	10416200	10416200	10416200	10416200

I=Indoor, E=Outdoor

Quantity is one unless otherwise indicated.

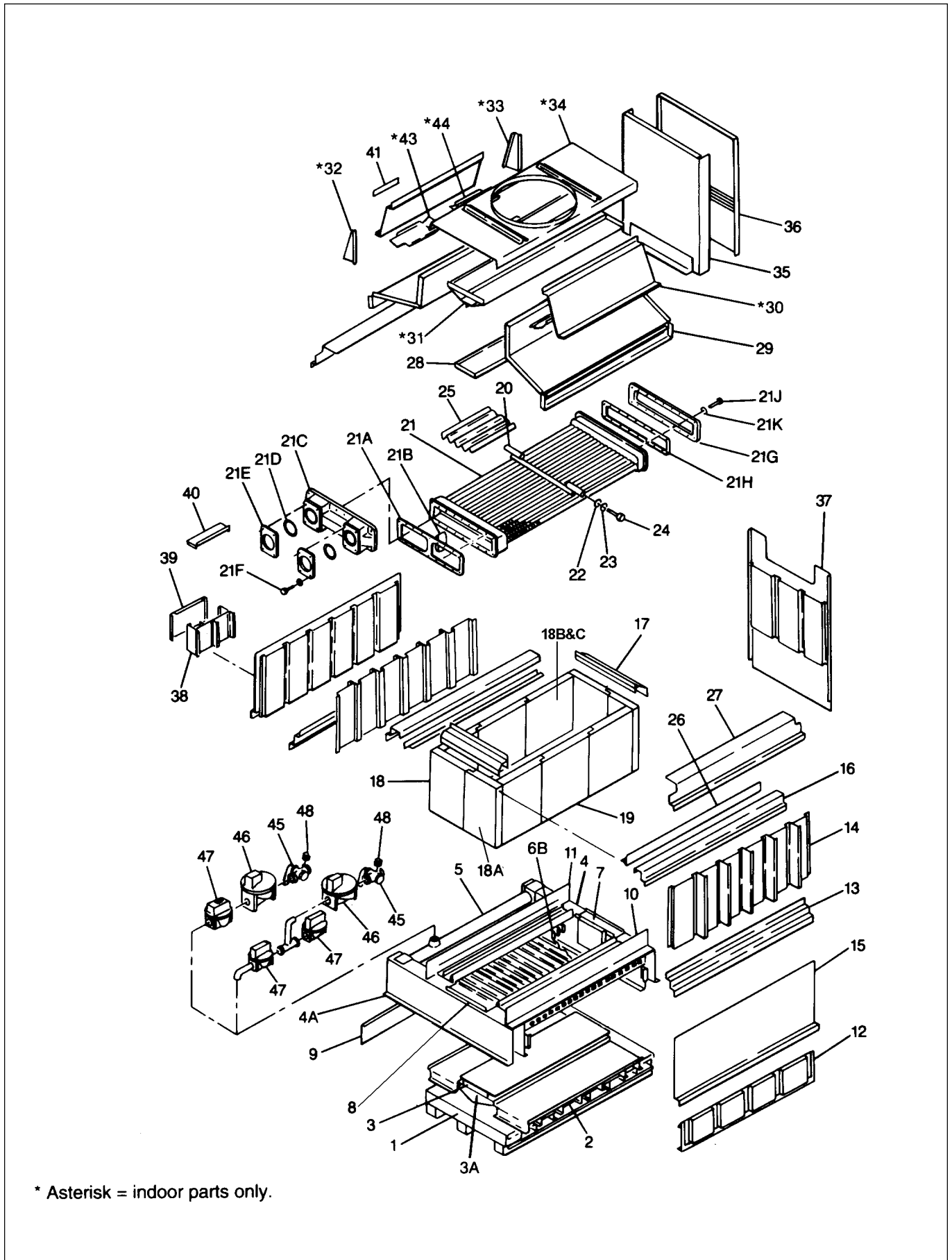

* Asterisk = indoor parts only.

Figure 14. Parts Identification.

Key No.	Description	Size 2000 I	Size 2450 I 2200 E	Size 3050 I 2800 E	Size 3500 I 3200 E	Size 4050 I 3600 E	Size 4500 I 4000 E	Size 5000 I 4500 E
21d.	Gasket, Flange	S0095600 (2)	S0095600 (2)	S0095600 (2)	S0095600 (2)	S0095600 (2)	S0095600 (2)	S0095600 (2)
21e.	Flange	10417400 (2)	10417400 (2)	10417400 (2)	10417400 (2)	10417400 (2)	10417400 (2)	10417400 (2)
21f.	Cap Screw-Hex. Hd. 1/2" - 13UNC x 2"	F0024500 (8)	F0024500 (8)	F0024500 (8)	F0024500 (8)	F0024500 (8)	F0024500 (8)	F0024500 (8)
21g.	Return Header	10416100	10416100	10416100	10416100	10416100	10416100	10416100
21h.	Gasket, Header	S0095300	S0095300	S0095300	S0095300	S0095300	S0095300	S0095300
21j.	Cap Screw-Hex. Hd. 1/2" - 13UNC x 1 1/2"	F0013300 (36)	F0013300 (36)	F0013300 (36)	F0013300 (36)	F0013300 (36)	F0013300 (36)	F0013300 (36)
21k.	Washer - 1/2"	F0010300 (36)	F0010300 (36)	F0010300 (36)	F0010300 (36)	F0010300 (36)	F0010300 (36)	F0010300 (36)
22.	Lock Washer - 3/8"	F0010800 (2)	F0010800 (2)	F0010800 (2)	F0010800 (2)	F0010800 (2)	F0010800 (2)	F0010800 (2)
23.	Washer - 3/8"	F0011100 (2)	F0011100 (2)	F0011100 (2)	F0011100 (2)	F0011100 (2)	F0011100 (2)	F0011100 (2)
24.	Cap Screw 3/8" - 16UNC x 3/4"	F0015900 (2)	F0015900 (2)	F0015900 (2)	F0015900 (2)	F0015900 (2)	F0015900 (2)	F0015900 (2)
25.	Heat Exchanger Baffle Assembly	20010900 (68)	20010900 (68)	20010900 (68)	20010900 (102)	20010900 (102)	20010900 (102)	20010900 (102)
26.	Heat Exchanger Baffle F & R	10534310 (2)	10534311 (2)	10534312 (2)	10534313 (2)	10534314 (2)	10534315 (2)	10534316 (2)
27.	Front & Rear Closure	20006401 (2)	20006402 (2)	20006403 (2)	20006404 (2)	20006405 (2)	20006406 (2)	20006407 (2)
28.	Inside Baffle Assembly Indoor Outdoor	20012501 N/A	20012502 20012509	20012503 20012510	20012504 20012511	20012505 20012512	20012506 20012513	20012507 20012514
29.	Flue Panel Assembly F & R	20011501 (2)	20011502 (2)	20011503 (2)	20011504 (2)	20011505 (2)	20011506 (2)	20011507 (2)
30.	Upper Panel F & R (indoor only)	20011701 (2)	20011702 (2)	20011703 (2)	20011704 (2)	20011705 (2)	20011706 (2)	20011707 (2)
31.	Flue Diverter Assembly (indoor only)	20012201	20012202	20012203	20012204	20012205	20012206	20012207
32.	Upper Wing F & R, Left (indoor only)	20006301 (2)	20006301 (2)	20006301 (2)	20006301 (2)	20006301 (2)	20006301 (2)	20006301 (2)
33.	Upper Wing F & R, Right (indoor only)	20006302 (2)	20006302 (2)	20006302 (2)	20006302 (2)	20006302 (2)	20006302 (2)	20006302 (2)
34.	Top Panel Assembly (indoor only)	20012301	20012302	20012303	20012304	20012305	20012306	20012307
35.	Flue End Assembly	20012000 (2)	20012000 (2)	20012000 (2)	20012000 (2)	20012000 (2)	20012000 (2)	20012000 (2)
36.	Upper End Assembly	20011900 (2)	20011900 (2)	20011900 (2)	20011900 (2)	20011900 (2)	20011900 (2)	20011900 (2)
37.	Lower End Panel Assembly	20011800 (2)	20011800 (2)	20011800 (2)	20011800 (2)	20011800 (2)	20011800 (2)	20011800 (2)
38.	Control Mounting Panel	20013700	20013700	20013700	20013700	20013700	20013700	20013700
39.	Control Cover - Front	20018700	20018700	20018700	20018700	20018700	20018700	20018700
40.	Control Box Cover Top	20011200	20011200	20011200	20011200	20011200	20011200	20011200

I=Indoor, E=Outdoor

Quantity is one unless otherwise indicated.

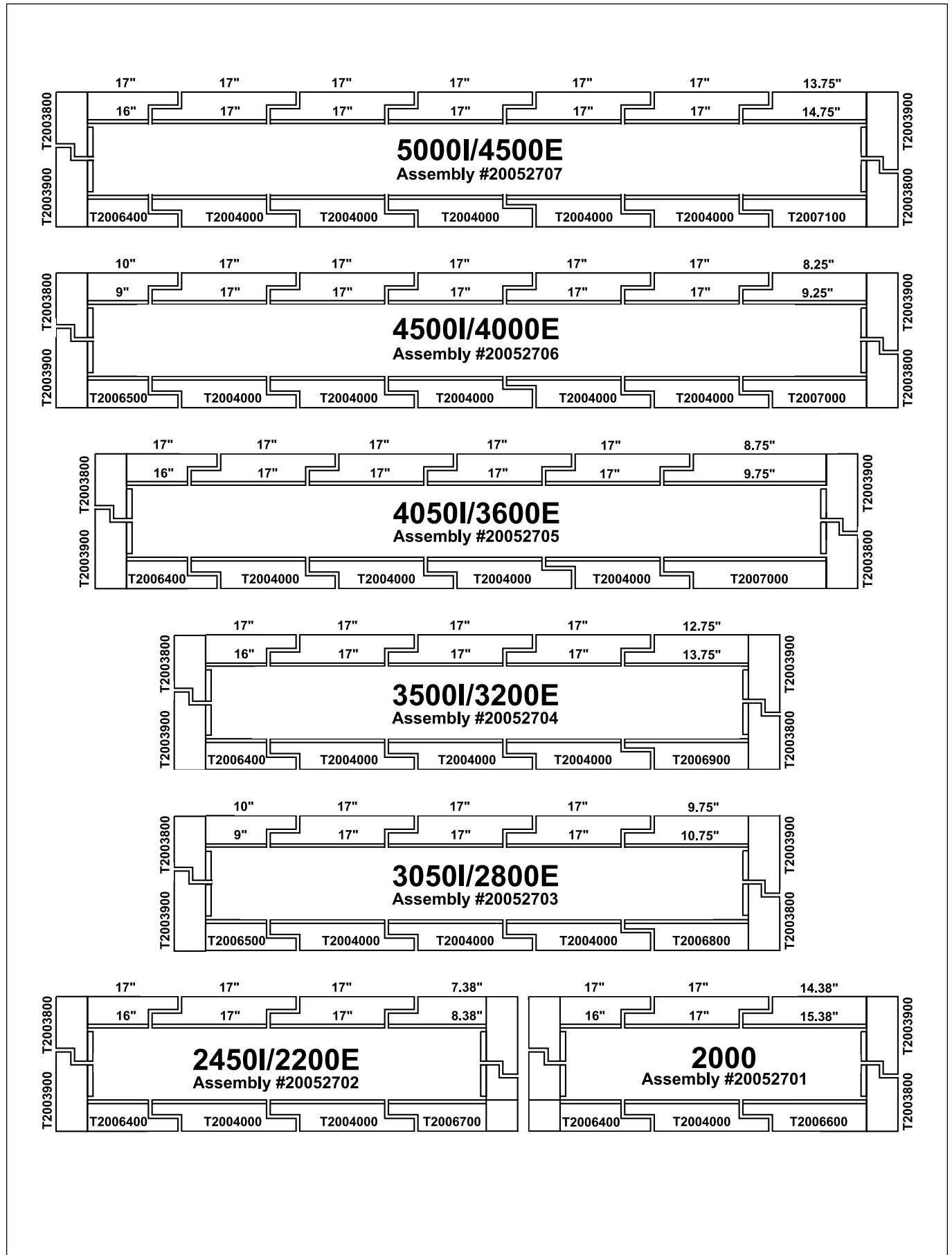

Figure 15. Tile Assembly.

Key No.	Description	Size 2000 I	Size 2450 I 2200 E	Size 3050 I 2800 E	Size 3500 I 3200 E	Size 4050 I 3600 E	Size 4500 I 4000 E	Size 5000 I 4500 E
41.	Pilot Lead Assembly (Johnson) Standing Pilot, Nat/Propane	20035403	20035403	20035403 (2)	20035403 (2)	20035403 (2)	20035403 (2)	20035403 (2)
	Pilot Lead Assembly (Honeywell) Standing Pilot, Nat/Propane	20035404	20035404	20035404 (2)	20035404 (2)	20035404 (2)	20035404 (2)	20035404 (2)
	Pilot Lead Assembly (Johnson) IID Pilot, Nat	20035401	20035401	20035401 (2)	20035401 (2)	20035401 (2)	20035401 (2)	20035401 (2)
	Pilot Lead Assembly (Honeywell) IID Pilot, Nat	20035402	20035402	20035402 (2)	20035402 (2)	20035402 (2)	20035402 (2)	20035402 (2)
42.	Pilot Shield	20016400	20016400	20016400 (2)	20016400 (2)	20016400 (2)	20016400 (2)	20016400 (2)
43.	Draft Hood Relief Baffle - Right (indoor only)	20013801 (2)	20013801 (2)	20013801 (2)	20013801 (2)	20013802 (2)	20013803 (2)	20013804 (2)
44.	Draft Hood Relief Baffle - Right (indoor only)	20013805 (2)	20013805 (2)	20013805 (2)	20013805 (2)	20013806 (2)	20013807 (2)	20013808 (2)
45.	Manual Valve	V0001800	V0001800	V2013800	V2013800	V2013800	V2013900	V2013900
46.	Safety Valve	V0046800	V0046800	V0046900	V0046900	V0046900	V2000500	V2000500
47.	Operating Valve	V0051400	V0051400	V2001000	V0051400 (2)	V0051400 (2)	V0051400 (2)	V0051400 (2)
48.	Manual Pilot Valve	W0002100	W0002100	W0002100 (2)	W0002100 (2)	W0002100 (2)	W0002100 (2)	W0002100 (2)
49(a).	Pilot Valve (I.I.D.) (not shown)	W0019300	W0019300	W0019300 (2)	W0019300 (2)	W0019300 (2)	W0019300 (2)	W0019300 (2)
49(b).	Pilot Relay (Standing Pilot)	W003000	W003000	W003000 (2)	W003000 (2)	W003000 (2)	W003000 (2)	W003000 (2)
50.	Pilot Burner (Johnson) Standing Pilot, Nat	W0034700	W0034700	W0034700 (2)	W0034700 (2)	W0034700 (2)	W0034700 (2)	W0034700 (2)
	Pilot Burner (Honeywell) Standing Pilot, Nat	W0034800	W0034800	W0034800 (2)	W0034800 (2)	W0034800 (2)	W0034800 (2)	W0034800 (2)
51.	Pilot Burner (Johnson) Standing Pilot, Propane	W0034600	W0034600	W0034600 (2)	W0034600 (2)	W0034600 (2)	W0034600 (2)	W0034600 (2)
	Pilot Burner (Honeywell) Standing Pilot, Propane	W0034400	W0034400	W0034400 (2)	W0034400 (2)	W0034400 (2)	W0034400 (2)	W0034400 (2)
52.	Pilot Burner (Johnson) IID Pilot, Nat	W0034500	W0034500	W0034500 (2)	W0034500 (2)	W0034500 (2)	W0034500 (2)	W0034500 (2)
	Pilot Burner (Honeywell) IID Pilot, Nat	W0034300	W0034300	W0034300 (2)	W0034300 (2)	W0034300 (2)	W0034300 (2)	W0034300 (2)



H0147600D

LAARS[®]
Heating Systems Company
A subsidiary of **BRADFORD WHITE**[®] Corporation

800.900.9276 • Fax 800.559.1583 (*Customer Service, Service Advisors*)
20 Industrial Way, Rochester, NH 03867 • 603.335.6300 • Fax 603.335.3355
1869 Sismet Road, Mississauga, Ontario, Canada L4W 1W8 • 905.238.0100 • Fax 905.366.0130
www.Laars.com

Litho in U.S.A. © Laars Heating Systems 0805 Document 1065D