

INSTALLATION, OPERATION AND MAINTENANCE INSTRUCTIONS, for the User and the Installer

HR s 320 - 600 - 800 - 1000
Jumbo 800 - 1000



GENERAL RECOMMENDATIONS	4
PRODUCT INFORMATION	5
Energy labelling	5
Rating Plate	6
USER'S GUIDE	7
Thermostat	7
APPLIANCE DESCRIPTION	8
Models - Types HR s 320 – 600 -800 - 1000 / Jumbo 800 - 1000	8
TECHNICAL CHARACTERISTICS	10
Dimensions	10
Electrical Characteristics (Option for HR s 320 - 600 - 800 - 1000)	13
Hydraulic Characteristics	13
Performance	14
INSTALLATION	15
Packing Contents	15
Tools	15
Safety Instructions	16
Preparation of the Tank (HR s type with soft casing)	18
Preparation of the Tank (Jumbo type with metal casing)	20
Connection	24
Parallel Tank Assembly (Typical - 3 tanks)	25
Connection Kits (option)	25

STARTING UP26

Filling28

MAINTENANCE.....29

Periodic Checks by the User29

Annual Maintenance.....29

Draining.....30

Bringing back into Service after Maintenance30

NOTES

This manual contains important information with respect to the installation, the starting up and the maintenance of the appliance.

This manual must be provided to the user, who will read it carefully and keep it in a safe place.

We accept no liability should any damage result from the failure to comply with the instructions contained in this technical manual.



Essential recommendations for safety

- It is strictly prohibited to carry out any modifications to the appliance without the manufacturer's prior and written agreement.
- The product must be installed by a qualified engineer, in accordance with applicable local standards and regulations.
- The installation must comply with the instructions contained in this manual and with the standards and regulations applicable to domestic hot water tanks.
- Failure to comply with the instructions in this manual could result in personal injury or a risk of environmental pollution.
- The manufacturer declines all liability for any damage caused as a result of incorrect installation or in the event of the use of appliances or accessories that are not specified by the manufacturer.



Essential recommendations for the correct operation of the appliance

- In order to ensure that the appliance operates correctly, it is essential to have it serviced by a certified installer or maintenance contractor every year.
- In case of anomaly, please call your installer for advice.
- Faulty parts may only be replaced by genuine parts.
- Our water heaters are designed and manufactured for the exclusive purpose of heating and storing domestic hot water.
- The domestic hot water heaters must only be heated using hot water in a closed circuit.



General remarks

- The availability of certain models as well as their accessories may vary according to markets.
- The manufacturer reserves the right to change the technical characteristics and features of its products without prior notice.
- The part number (P/N) and serial number (S/N) of the appliance are indicated on its rating plate and must be provided to ACV in case of warranty claim. Failure to do so will make the claim void.
- In spite of the strict quality standards that ACV applies to its appliances during production, inspection and transport, faults may occur. Please immediately notify your approved installer of any faults.

ENERGY LABELLING

PRODUCT FICHE

ACV International
 Oude Vijverweg 6
 B-1653 Dworp
 Belgium



Product Models HR s 320
 HR s 600
 HR s 800
 HR s 1000
 Jumbo 800
 Jumbo 1000



General purpose hot water storage tank



	HR s				Jumbo	
	320	600	800	1000	800	1000
Energy efficiency class	D	-	-	-	-	-
Standing Loss *	122W	153W	167W	181W	142W	154W
Storage volume	318L	606L	800L	1000L	800L	1000L

* According to EN12897:2006

RATING PLATE

	Oude Vijverweg 6, 1653 Dworp BELGIUM www.acv.com	Type : HR s 320	
		P/N : A1002047	Year : 2015
		S/N : A001500	

Standard: EN 12897:2006			
Sanitary Operating Pressure	8,6 bar		
Primary Operating Pressure	4 bar		
Maximum Design Pressure	10 bar		
Primary Heating Power Input	76 kW		
Primary Flow Rate	1,81 L/s		
Actual Capacity	318 L		
Standing Heat Loss	2,93 kWh/24h		
Maximum Temperature	90 °C		
Rated Voltage	230V 50 Hz		
			
(21) 00000 (91) 00000000 (92) 9999			

THERMOSTAT

The thermostat is optional for the HR s type tanks equipped with a soft casing, but is standard for the Jumbo type tanks with a metal casing.

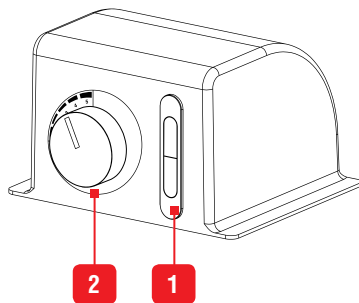

Legend :

1. **Thermometer** : indicates the domestic hot water (DHW) temperature in the tank.
2. **Adjusting knob** : allows to define the DHW preset temperature. It rotates 1/4 turn clockwise to set the temperature between 60°C and 90°C.

Wiring Diagram (Jumbo 800 - 1000)

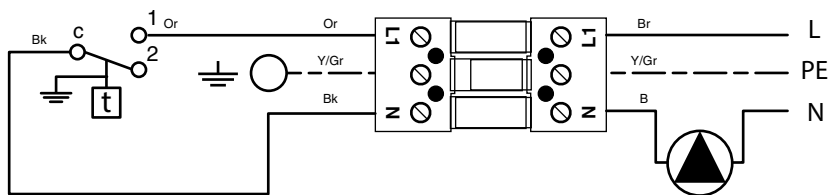

- B. Blue
- Br. Brown
- Bk. Black
- Or. Orange
- Y/Gr. Yellow / Green

MODELS - Types HR s 320 – 600 -800 - 1000 / Jumbo 800 - 1000

Indirectly heated storage water tanks, to be installed on the floor, equipped with a large surface heat exchanger and intended for medium and high power installations. Through the use of a specific kit, these tanks can be set in parallel, allowing the construction of high flow rate assemblies for any type of commercial, residential or industrial facilities.

HR s 320 - 600**Legend**

1. DHW outlet
2. Manual air bleed valve
3. Cold water inlet
4. Black rigid polypropylene cover
5. Stainless steel dry-well
6. 70 mm soft insulation (open-cell polyurethane foam)
7. Outer vinyl casing with zip fastener
8. Auxiliary DHW loop
9. Primary circuit inlet
10. Inner stainless steel tank
11. Outer steel (primary) tank
12. Primary circuit outlet

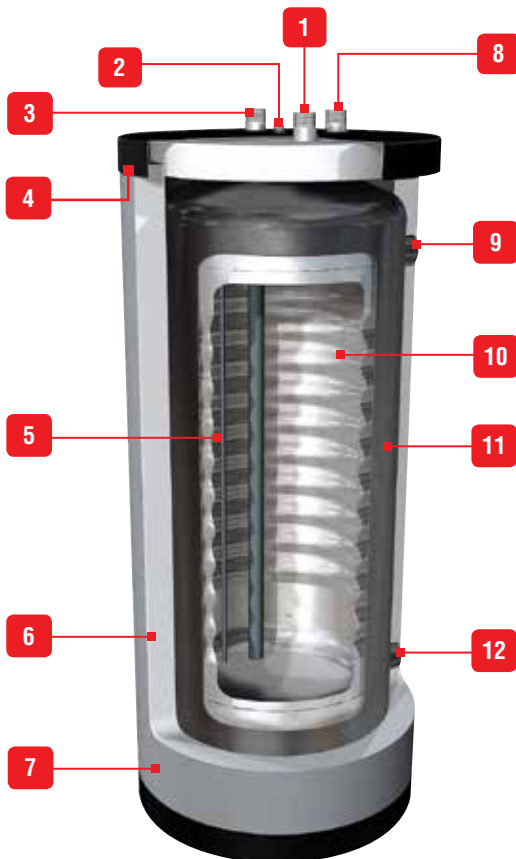

HR s/Jumbo 800 - 1000

Legend

1. DHW outlet
2. Auxiliary DHW loop
3. Cold water inlet
4. Primary circuit inlet
5. Inner stainless steel tank
6. Primary circuit outlet
7. Hand hole
8. Stainless steel dry-well
9. Manual bleed valve
10. Outer (primary) steel tank

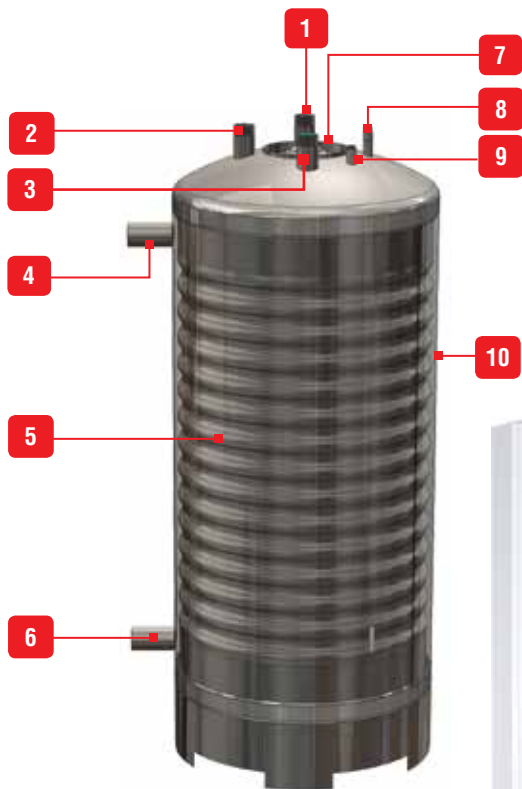

Tank shown without insulation

Jumbo 800 - 1000 with metal casing

11. Thermometer
12. Adjusting knob
13. 120 mm rock wool insulation (not shown)
14. Metal casing



DIMENSIONS

Tank dimensions (soft casing)

		HR s			
		320	600	800	1000
A = Height	mm	1600	1895	1955	2355
B = \emptyset	mm	558	703	780	780
C	mm	255	255	335	335
D	mm	1285	1585	1585	1985
E = \emptyset	mm	270	270	360	360
F = \emptyset	mm	700	845	920	920
Empty weight	Kg	106	201	261	308

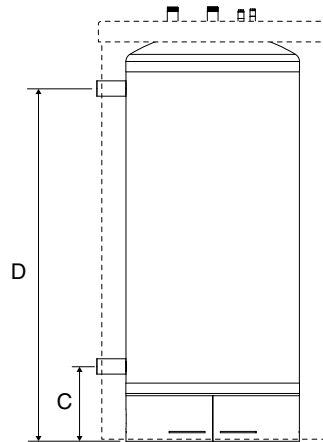
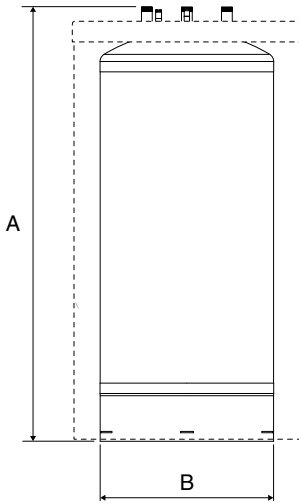

HR s 320 - 600

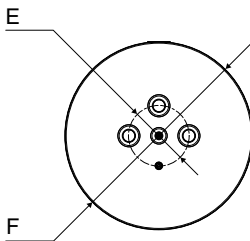

HR s 800 - 1000

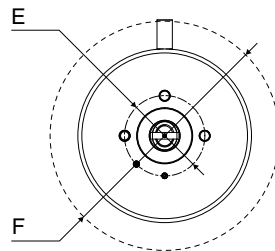

Tank clearance		HR s			
		320	600	800	1000
D1 (mm)	Recommended (1 tank)	1000	1000	1000	1000
	Minimum (parallel assy.)	425	425	550	550
D2 (mm)	Recommended	1000	1000	1000	1000
	Minimum	800	800	800	800
Height (mm)	Recommended	250	250	300	300
	Minimum	150	180	210	180

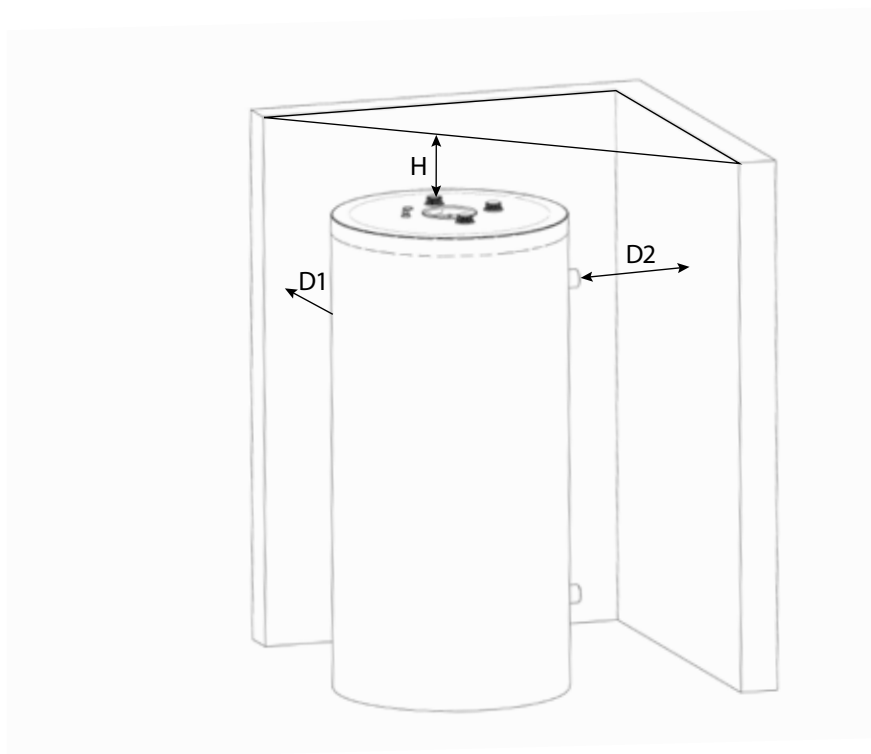

Tank dimensions

Jumbo

		800	1000
A = Height	mm	1955	2355
B = \emptyset	mm	780	780
C	mm	335	335
D	mm	1585	1985
E = \emptyset	mm	360	360
F	mm	1030	1030
Empty weight	Kg	360	380

Tank clearance

D1 (mm)	Recommended (1 tank)	1000	1000
	Minimum (parallel assy)	550	550
D2 (mm)	Recommended	1000	1000
	Minimum	800	800
H (mm)	Recommended	300	300
	Minimum	210	180

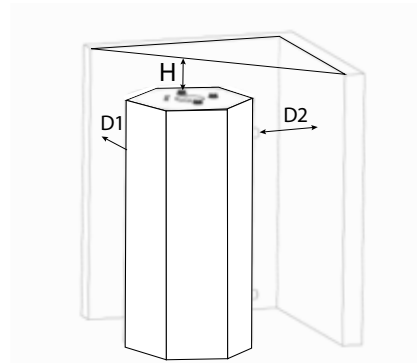
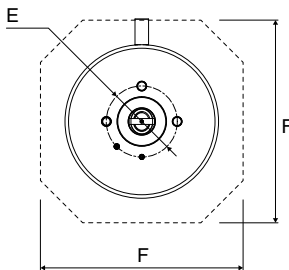
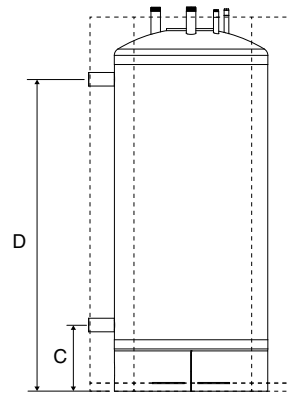
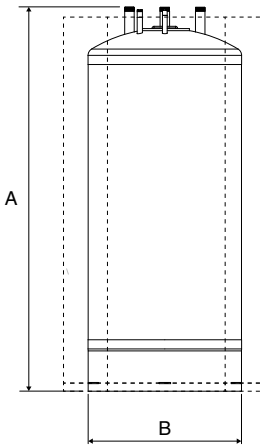

ELECTRICAL CHARACTERISTICS (Option for HR s 320 - 600 - 800 - 1000)

Main characteristics		HR s		HR s / Jumbo	
		320	600	800	1000
Rated voltage	V~	230/240	230/240	230/240	230/240
Rated frequency	Hz	50	50	50	50
Max. power	kW	1.3	1.3	1.3	1.3
Max. amp. rating (fuse)	A	6	6	6	6

HYDRAULIC CHARACTERISTICS

Main characteristics		HR s				Jumbo	
		320	600	800	1000	800	1000
Total capacity	L	318	606	800	1000	800	1000
Primary circuit capacity	L	55	161	125	160	125	160
DHW capacity	L	263	445	675	840	675	840
Primary circuit connection [F]	"	2	2	2	2	2	2
DHW connection [M]	"	1 1/2	1 1/2	1 1/2	1 1/2	1 1/2	1 1/2
Auxiliary DHW loop connection [M]	"	1 1/2	1 1/2	1 1/2	1 1/2	1 1/2	1 1/2
Primary pressure drop*	mbar	—	—	—	—	—	—
Heating surface area*	m ²	2.65	3.58	4.56	5.50	4.56	5.50
Max Design Pressure*	bar	10	10	10	10	10	10
Reheat Performance - Primary Heating Power Input*	kW	60	71	82	97	82	97
Primary flow rate (to achieve Reheat Performance)*	L/s	1.81	2.08	2.08	2.08	2.08	2.08
Standing Heat Loss*	kWh/24h	2.93	3.67	4.01	4.34	3.41	3.70
	W	122	153	167	181	142	154

* According to EN12897:2006

PERFORMANCE

DHW performance		HR s		HR s/Jumbo	
		320	600	800	1000
Operating conditions at 80°C					
Peak flow at 40 °C	L/10'	922	1345	1881	2265
Peak flow at 45 °C	L/10'	790	1153	1612	1941
Peak flow at 60 °C	L/10'	504	706	961	1145
Peak flow at 40 °C	L/60'	2732	3437	4270	4940
Peak flow at 45 °C	L/60'	2342	2946	3660	4234
Peak flow at 60 °C	L/60'	1402	1733	2124	2438
Constant flow at 40 °C	L/h	2172	2511	2868	3210
Constant flow at 45 °C	L/h	1862	2152	2458	2751
Constant flow at 60 °C	L/h	1077	1232	1395	1562
Coefficient	NL	18	34	67	87

Maximum Operating Conditions		HR s		HR s/Jumbo	
		320	600	800	1000
Max. operating pressure - primary	bar	4	4	4	4
Max. operating pressure - DHW	bar	8.6	8.6	8.6	8.6
Supply pressure (DHW circuit)	bar	6	6	6	6
Maximum temperature - heating side	°C	90	90	90	90
Maximum temperature - DHW side	°C	80	80	80	80

- Water quality
- Chlorides < 150 mg/L
 - 6 ≤ pH ≤ 8
 - If hardness > 20°FH, water softener recommended.



HR s tanks built with Duplex material provide identical DHW performance but have a better resistance to chlorides (2000 mg/L) than those built with 304 Stainless steel (150 mg/L).

PACKING CONTENTS

All appliances are delivered, tested and packed separately.

HRS tanks

Box 1: tank + multilingual Installation, Operation and Maintenance Instruction manual + rating plate.

Box 2: Soft insulation

Box 3: Insulation accessories (caps, cover, etc.)

Jumbo tanks

Box 1: tank + multilingual Installation, Operation and Maintenance Instructions.

Box 2: Metal casing and base to be assembled + hardware + thermometer and thermostat to be installed.

Box 3: Rolls of 60mm rock wool insulation.

For the installation of the casing, refer to "Preparation of the Tank", pages 18 and 20



If a rating plate is provided, make sure to place it on the outer casing of the tank, so that it is easily accessible and legible.

TOOLS

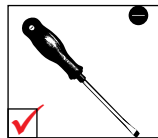
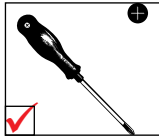
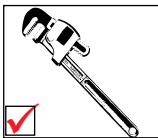
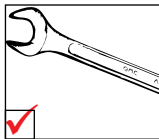
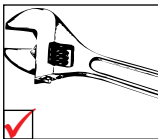

SAFETY INSTRUCTIONS



General remarks

- Connections (electrical, hydraulic) must be carried out in accordance with applicable standards and regulations.
- If the water drawing off point is far from the tank, installing an auxiliary DHW loop can allow to get hot water more quickly at all times.



Essential instructions for the correct operation of the system

- The tank must be installed in a dry and protected area.
- Install the appliance to ensure easy access at all times.
- To avoid any risk of corrosion, connect the stainless steel tank directly to the earth.
- Make sure to install a pressure reducing valve set at 4.5 bar in the DHW circuit if the supply pressure is higher than 6 bar.
- On the DHW circuit, install an approved safety group, comprised of a safety valve set at 7 bar, a check valve and a stop valve.
- Make sure that the outlet of the safety unit goes directly to the sewer to avoid any potential damage.
- Do not install the safety group above the tank to avoid water discharge on to the tank.



Essential instructions for the safety of persons and the environment

- **Hot water can burn!**
In the event of small amounts of hot water repeatedly being drawn off, a stratification effect can develop in the tank. The upper hot water layer may then reach very high temperatures.
- ACV recommends using a pre-set thermostatic mixing valve in order to provide hot water at a maximum of 60°C.
- Water heated to wash clothes, dishes and for other uses can cause serious burns.
- In order to avoid exposure to extremely hot water that can cause serious burns, never leave children, old people, disabled or handicapped people in the bath or shower alone.
- Never allow young children to turn on the hot water or fill their own bath.
- Adjust the water temperature in accordance with usage and plumbing regulations.
- The risk of developing bacteria exists, including “Legionella pneumophila”, if a minimum temperature of 60°C is not maintained in both the DHW tank and the hot water distribution network.



Essential instructions for the electrical safety

- Only an approved installer is authorized to carry out the electrical connections.
- Install a 2-way switch and a fuse or circuit breaker of the recommended rating outside the appliance, so as to be able to shut power down when servicing the appliance or before performing any operation on it.
- Shut down external electrical supply of the appliance before performing any operation on the electrical circuit.
- This appliance is not intended for use by persons (including children) with reduced physical, sensory or mental capabilities, or lack of experience and knowledge, unless supervised or unless they have been given instruction concerning the use of the appliance by a person responsible for their safety.

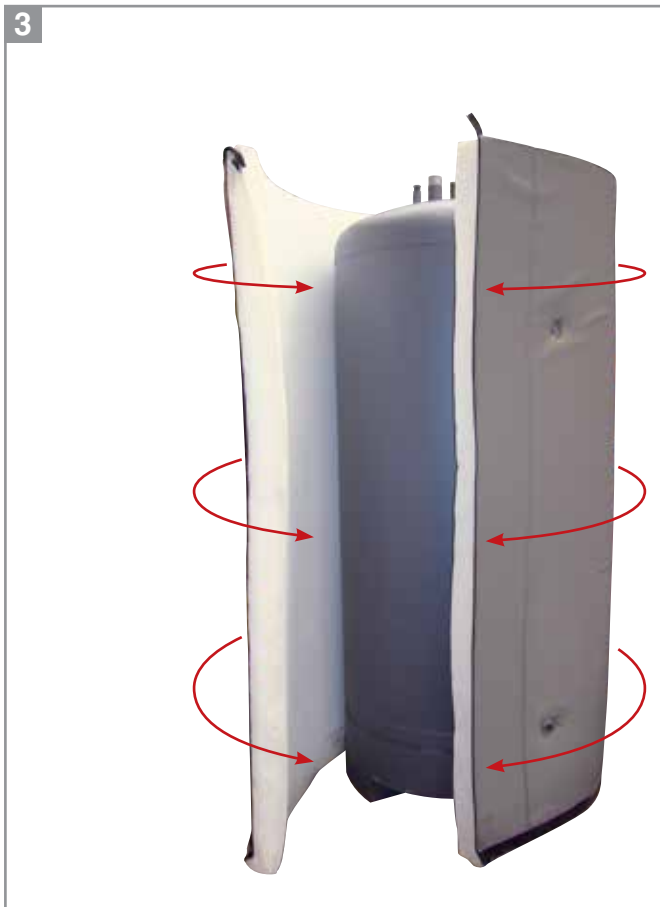
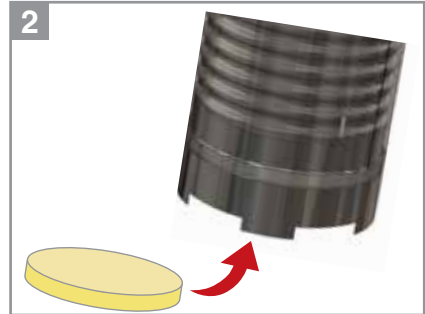
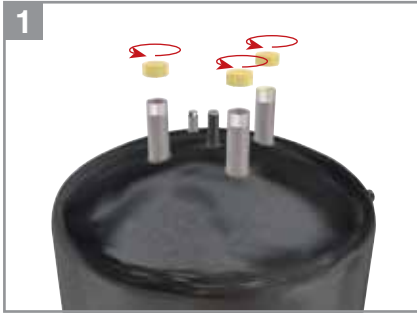
PREPARATION OF THE TANK (HR s type with soft casing)

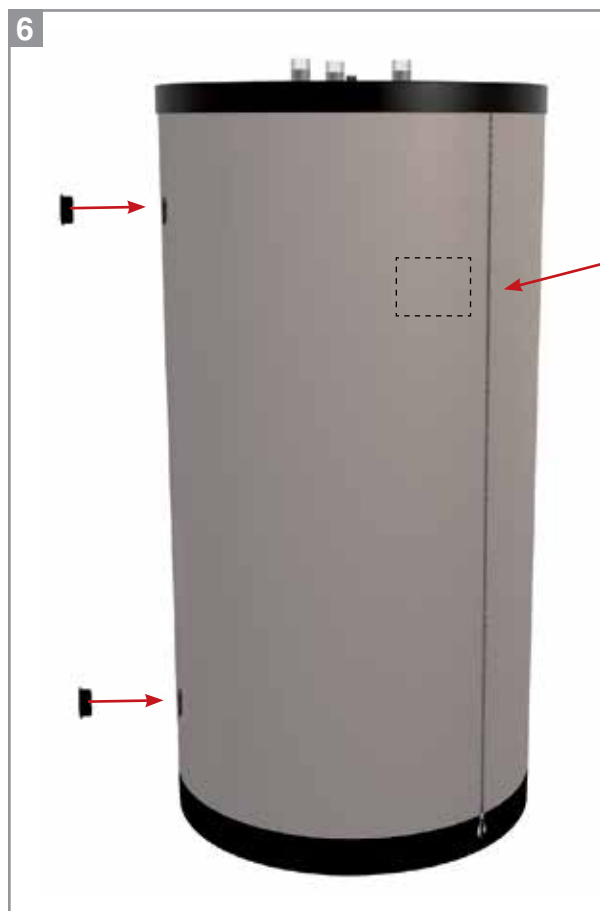

Install the rating
plate sticker here.

PREPARATION OF THE TANK (Jumbo type with metal casing)

Consumable products :



Hardware :



Steps :

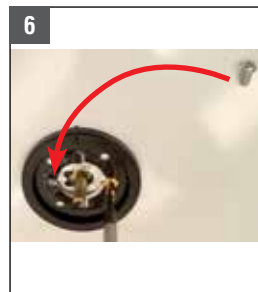
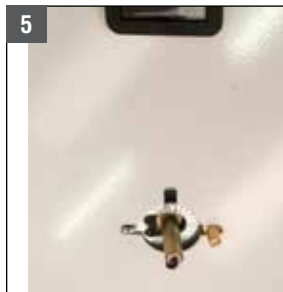
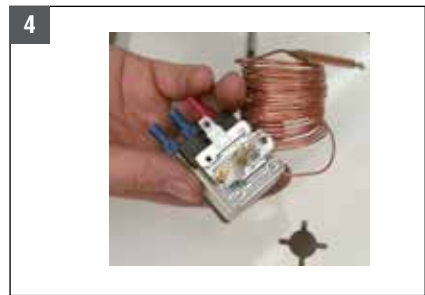
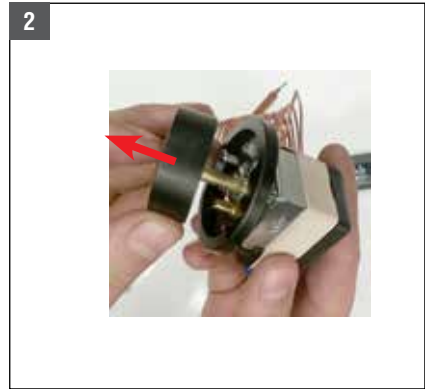

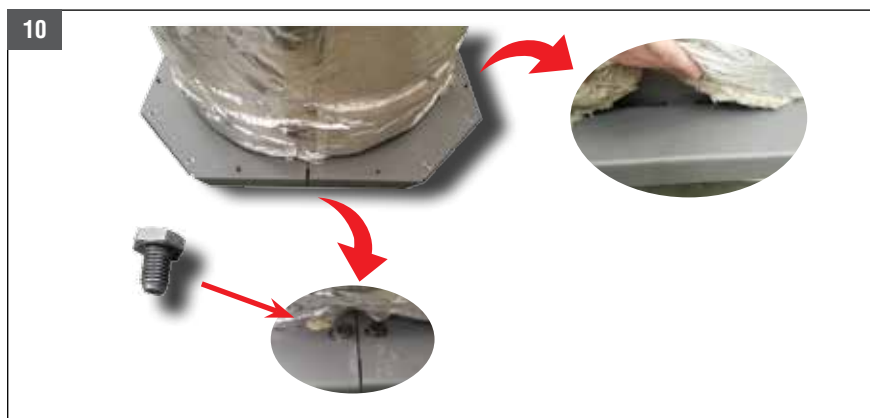
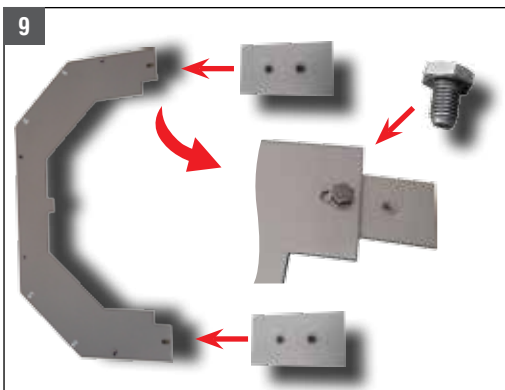
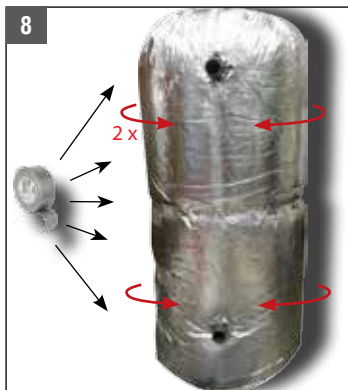

12

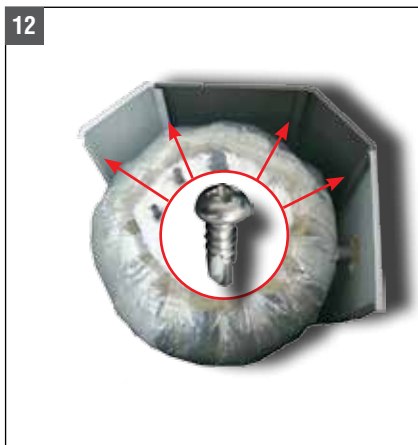

13



14



15

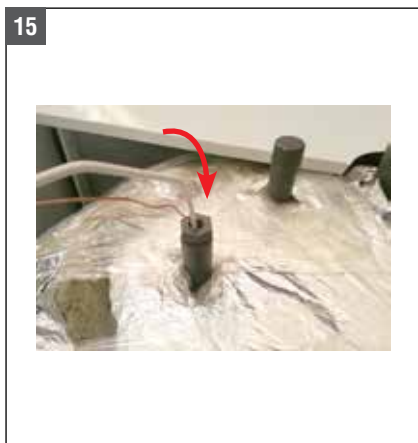

16



CONNECTION



Essential instructions for the safety of persons and the environment

- Refer to the safety instructions for the installation. Failure to comply with these instructions can result in damages to the system, severe injuries or death.
- Hot water can burn! ACV recommends using a pre-set thermostatic mixing valve in order to provide hot water at a maximum of 60°C.



Essential instructions for the correct operation of the system

- The filling circuit of the DHW tank must be equipped with a safety group, comprised at least of a stop valve, a check valve, a safety valve set at 7 bar, and possibly, an expansion vessel of the appropriate size. Make sure that the circuit between the tank and the safety valve is always open.
- The third DHW tank connection, if any, can be used for the auxiliary DHW loop. If the connection is not used, replace the protective plug by a brass plug of the appropriate size.



General remarks

- In certain countries the domestic kits must be approved.
- The circuit illustrations are basic principle diagrams only.

CONNECTION TO THE DHW CIRCUIT (Typical floor installation)

Key

1. Filling valve
2. Pressure reducing valve (set at 4.5 bar)
3. Check valve
4. Expansion vessel
5. Safety valve (set at 7 bar)
6. Drain valve
7. Hot water outlet
8. Pressure gauge
9. Grounding
10. Stop valve
11. Thermostatic mixing valve

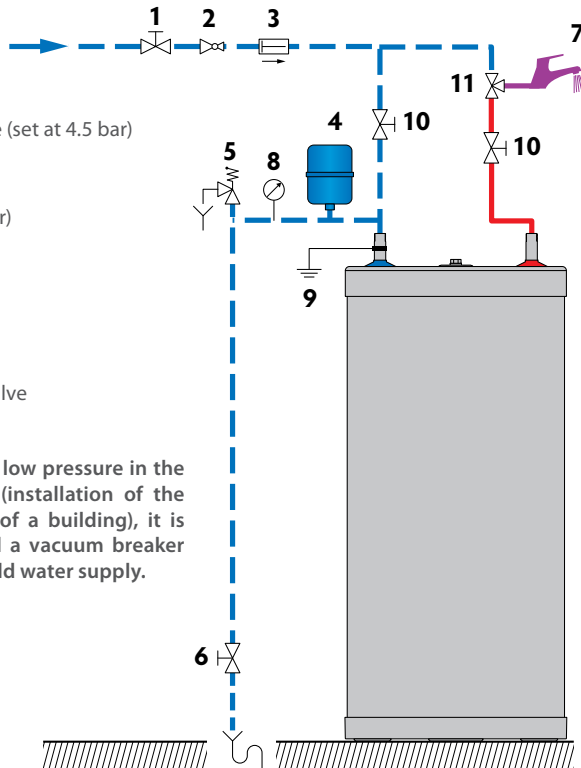

If there is a risk of low pressure in the hot water circuit (installation of the tank on the roof of a building), it is essential to install a vacuum breaker device onto the cold water supply.

--- Cold water
 --- Hot water

CONNECTION TO THE PRIMARY CIRCUIT (Typical floor installation)

Key

1. Primary circuit filling valve
2. Charging pump
3. Check valve
4. Primary circuit stop valve
5. Expansion vessel
6. Pressure gauge
7. Safety valve
8. Drain valve
9. Stop valve

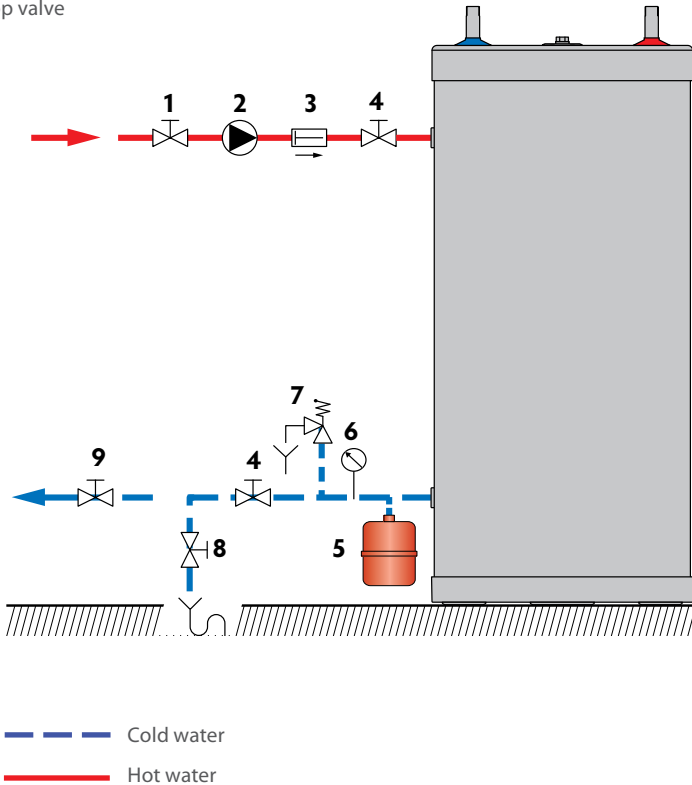

PARALLEL TANK ASSEMBLY (Typical - 3 tanks)

Recommended assembly for any waste heat recovery system and for district heating applications.



This type of connection reduces the water heating performance of the system. Make sure to oversize the assembly. A specific connection kit is required to build this type of assembly.

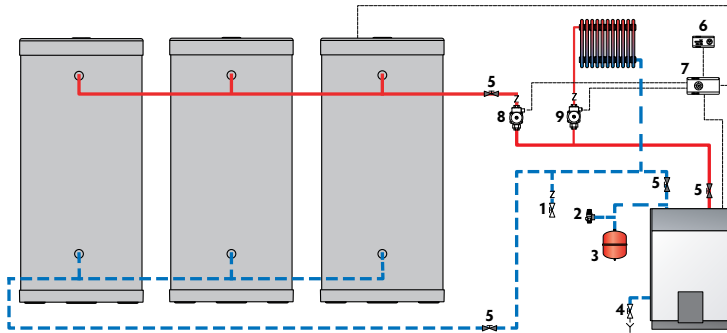

Legend

- | | |
|----------------------------------|----------------------------|
| 1. Primary circuit filling valve | 6. Room thermostat |
| 2. Safety valve | 7. Boiler control (option) |
| 3. Expansion vessel | 8. Charging pump |
| 4. Drain valve | 9. Primary circuit pump |
| 5. Primary circuit stop valve | |

CONNECTION KITS (OPTION)

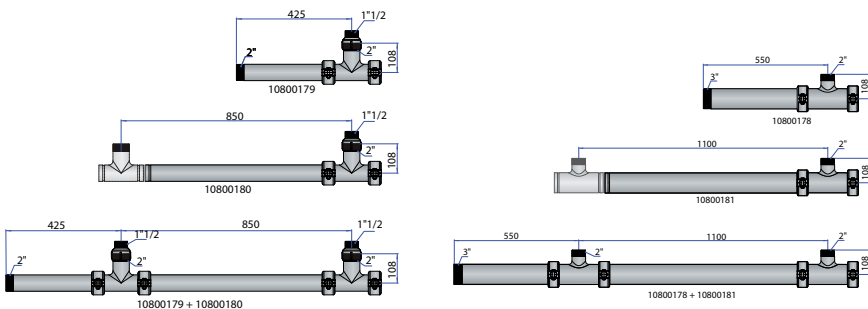

HR s type : 10800179 - 10800180

HR s / Jumbo type : 10800178 - 10800181

SAFETY INSTRUCTIONS TO FILL THE TANK



Essential instructions for the safety of persons and the environment

- The DHW tank must always be filled and pressurised before filling and pressurising the primary circuit.
- Do not use vehicle antifreeze. This can cause serious injury or death, or damage facilities.
- If antifreeze is needed in the primary circuit, it must comply with Public Hygiene Regulations and must be non-toxic. A food-grade Propylene Glycol is recommended. It must be diluted according to the ratio recommended in the local regulations.
- Consult the manufacturer to determine the compatibility of the antifreeze with the tank's construction materials.



Essential instructions for the correct operation of the system

- Before bringing the tank into service, check the connections to avoid any risk of leaks during filling.
- Only use drinking water to check that the DHW tank is watertight. The on-site test pressure must not exceed a pressure surge of 8,6 bar.
- Using antifreeze in the primary circuit will lead to a reduction in the heating performance. The higher the concentration of antifreeze in the circuit, the lower the performance.

FILLING

 Essential instruction for the correct operation of the system

- The DHW tank must always be filled and pressurised before filling and pressurising the primary circuit.

FILLING THE DHW TANK (Figure 1)

 General remark

- Connect the safety valve outlet to the sewer.
1. To fill the tank, open a hot water tap (2) located at the highest point of the system. It enables to bleed the air from the system.
 2. Open the filling valve (1) and the stop valves (3) to fill the DHW tank.
 3. Close the hot water tap (2), after the water flow has stabilised and the air has been completely evacuated.
 4. Check all the connections of the system for leaks.

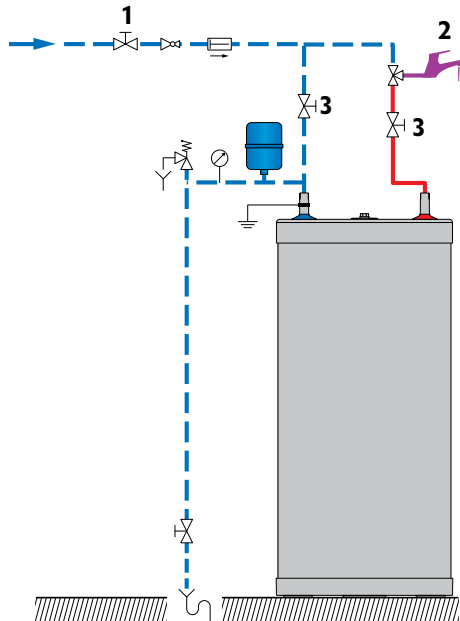

Figure 1

FILLING THE PRIMARY CIRCUIT (Figure 2)



General remark

- If the tank is used within a heating system, refer to the heating boiler manual.
1. Check that the drain valve (3) of your primary circuit is tightly closed.
 2. Open the stop valves (1) and (2) of the primary circuit connected to the heating boiler.
 3. Open the air bleed valve (4) located on the top of the hot water tank.
 4. When the air is eliminated, close the air bleed valve (4). Make sure the air bleed valve is tight.

— Cold water
— Hot water

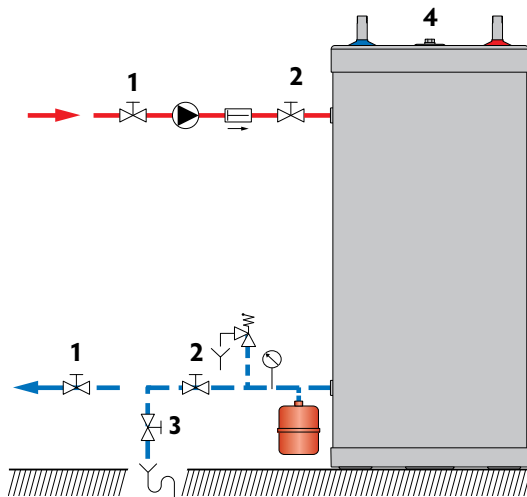

Figure 2

CHECKS BEFORE STARTING UP

- Check that the safety valves (DHW and primary) are correctly installed and that the outlets are connected to the sewer.
- Check that the DHW tank and the primary circuit are filled with water.
- Check that the air has been correctly bled from both circuits.
- Check that the tank's upper air bleed valve is tight.
- Check that the water side and heat source side pipes are correctly connected and not leaking.

STARTING UP



To put the installation into service, refer to the heating boiler manual.

PERIODIC CHECKS BY THE USER

- Check the pressure of the primary circuit pressure gauge: it should be between 0.5 and 1.5 bar.
- Visually inspect, on a regular basis, the valves, connections and accessories in order to detect any leaks or malfunction.
- Periodically check the air bleed valve located on the tank top to ensure that it is not leaking.
- Check that the DHW water circuit safety valves are in good operating condition.
- In the event of a problem, please contact an engineer or your installer.

ANNUAL MAINTENANCE



Essential instructions for the correct operation of the appliance

- The discharge pipe of the safety unit must be open to the outside. If the safety unit drips periodically, it may be due to an expansion problem or clogging of the valve.
- For internal inspections, the hand hole can be used. If there is none, use one of the water connections to insert the appropriate inspection equipment. If necessary, drain the tank before inspection.

The annual maintenance service, performed by an engineer, must include:

- A check of the air bleed valve: the bleeding of air can lead to the need for adding water to the system.
- A check of the primary and DHW circuit pressure gauges.
- The manual activation of the storage water circuit safety valve once a year. This operation will lead to a discharge of hot water.
- A check of the correct operation of valves, taps, control units and accessories that are possibly installed [refer to the manufacturer's instructions if necessary].

DRAINING



Essential instruction for the safety of persons and the environment

- The water coming out of the drain valve is very hot and can cause very severe burns. Make sure the area around the hot water flow is clear of people.



Essential instruction for the electrical safety

- Shut down the external electrical supply of the appliance before draining.



Essential instructions for the correct operation of the system

- Drain the tank if it is not used in winter and is at risk from exposure to ice. If the primary circuit water contains antifreeze, only the DHW tank must be drained. If the heating circuit does not contain antifreeze, the heating circuit and domestic water must be drained.
- Before draining the DHW, isolate the tank and lower the pressure of the heating circuit to 1 bar, in order to prevent the DHW tank from being crushed.

DRAINING THE PRIMARY CIRCUIT (Figure 3)

To drain the primary circuit of the hot water heater:

1. Stop the charging pump.
2. Isolate the primary circuit by closing the stop valves (1).
3. Connect the drain valve (2) to the sewer using a flexible hose.
4. Open the drain valve (2) and drain the water from the primary circuit to the drain.
5. Open the tank's air bleed valve (3) to accelerate drainage.
6. Close the drain valve (2) and air bleed valve (3) after draining the tank.

DRAINING THE DHW TANK (Figure 4)

To drain the hot water heater's DHW tank:

1. Open fully the hot water tap (3) for at least 60 minutes to make sure the DHW tank has cooled down sufficiently.
2. Close the filling valve (1) and the stop valve (4).
3. Connect the drain valve (2) to the sewer using a flexible hose.
4. Open the drain valve (2) and drain the water from the DHW tank to the sewer.
5. To accelerate the tank's drainage, open a hot water tap located higher than the tank connection in the DHW circuit.
6. Close the drain valve (2) and the hot water tap (3) after having drained the DHW tank.

BRINGING BACK INTO SERVICE AFTER MAINTENANCE

Refer to chapter "Starting up".

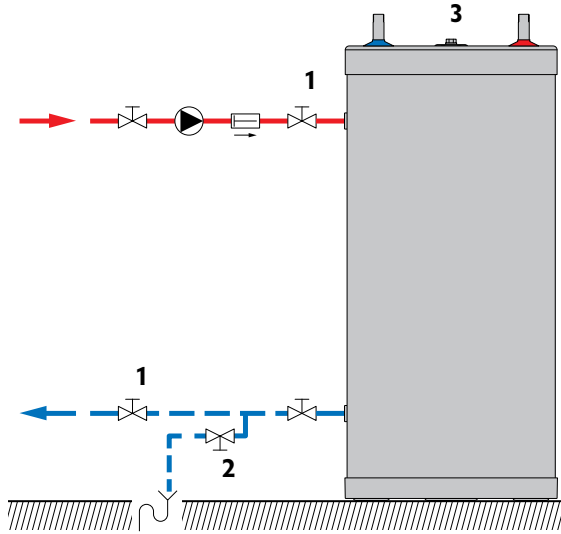

Figure 3

— Cold water
— Hot water

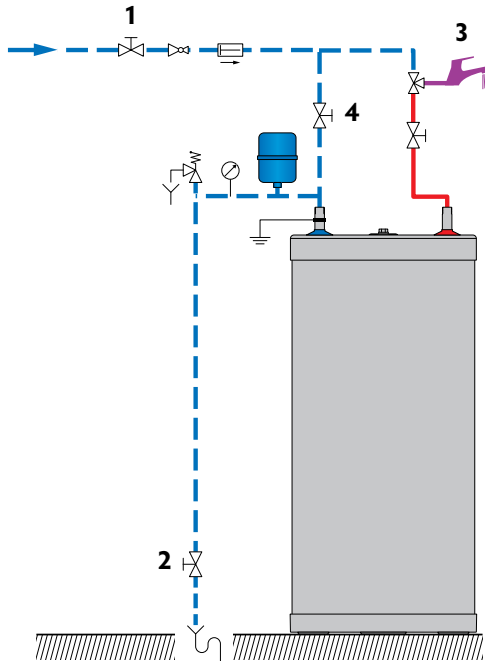

Figure 4



A series of horizontal dotted lines for writing, starting from the top right of the notepad illustration and extending across the width of the page.