



Alpha Climatic Programmable Modulating Boiler Energy Manager

*Part No 3.022144 (Hard Wired)
Part No 3.022143 (Radio Frequency)*

Installation and User Instructions

1. Description

The Alpha Climatic energy manager is a programmable modulating room thermostat capable of controlling time and temperature for heating varying the primary flow temperature depending on the room temperature.

The controller also allows remote control of the hot water function and other boiler features.

Connection to the boiler is via a two core cable to the low voltage bus connection for hard wired version or via an integrated RF receiver for the RF version.

2. Mounting of the Controller

The controller must be mounted in a position where it can not be influenced by direct sunlight, any device which might emit heat, near a door, window or be obstructed by curtains. It must be installed approximately 1.5m from the floor and any radiators within the same room must not have thermostatic radiator valves or any other thermostatic control fitted to them.

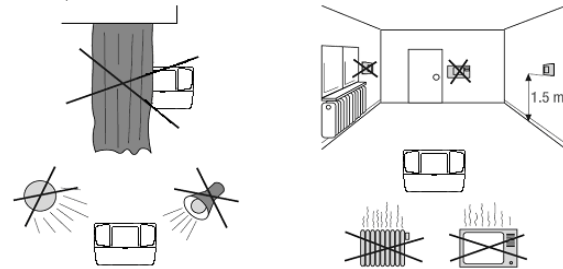

Fig 1

3. Fixing the Programmer to the Wall

Using a small screwdriver press down on the tab at the top of the controller (4) and separate the front control panel from the rear case.

Hold the rear casing in its chosen position level against the wall and mark the fixing holes.

Drill two 5mm holes in the wall, insert the wall plugs provided and fix the rear case to the wall using the 30mm screws.

Connect the boiler data wire to the + and – terminals in the rear casing (hard wired only).

Re-fit the front control panel, lower the control cover (1) and secure the control panel using the two 10mm screws provided (3).

Note; If an RF controller is being used then the data wire is not required but two AA batteries must be fitted.

Installing the batteries (RF controller only)

Using a small screw driver un-clip the bottom of the battery cover (2) and remove. Insert two Size AA batteries in the position shown in the back of the battery compartment and refit the battery cover

Note; The RF Climatic must not be programmed until the receiver unit is connected to the boiler and RF communication is established.

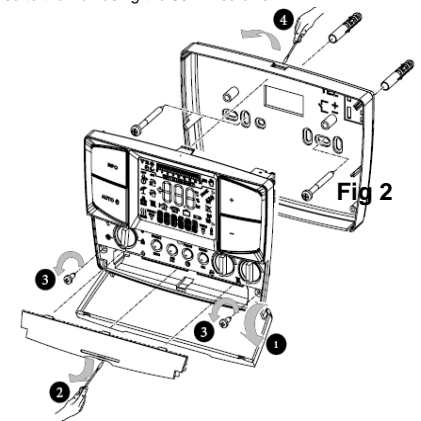

Fig 2

4. Connecting the Climatic Controller (Hard Wired)

Gain access to the boiler terminal block as described in the boiler installation and service instructions section 4.10. Pass the wire from the Climatic controller through the rubber grommet in the terminal block cover and connect it to terminals 12 and 13 (BUS). Secure the wire under the cable clamp and re-assemble in reverse order.

Installing the receiver (RF models only)

Gain access to the boiler terminal block as described in the boiler installation and service instructions section 4.10. Remove the screws from the fixing posts in the back of the control panel, position the receiver and re-fit the screws to secure it in place. Connect the wires from the receiver terminal to the BUS connection on the boiler terminal block. See fig 3. Tuck the wire behind the tabs on the PCB cover and re-assemble in reverse order.

Note: Remove the link between terminals 1 and 2 when connecting either Climatic heating controller.

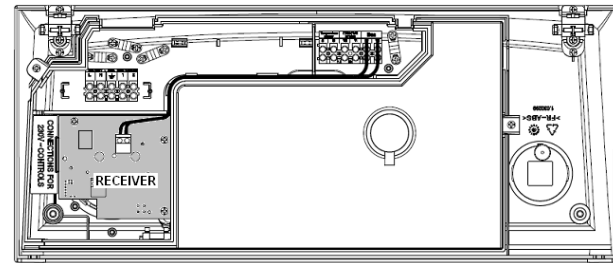

Fig 3

5. Control button functions.

1. Mode selection switch
2. Reset, previous display
3. Heating/Cooling on-off temperatures
4. Reset remote settings
5. Programming menu selection
6. Menu selection
7. DHW temperature set
8. CH temperature set
9. Information e.g. flow temperature
10. Auto/Manual override
11. Scroll/temperature adjust
12. Scroll/temperature adjust

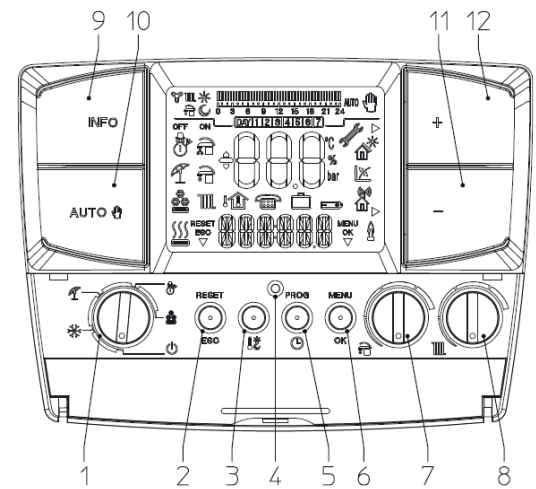





















Fig 4

6. Display Symbol Descriptions

Symbol	Description	Symbol	Description
	DHW and heating on		Outside temp. display
	DHW only		Inside temp. display
	Cooling and DHW modes enabled		Remote phone activation
	Request for heating or cooling		Holiday mode
	Cylinder heating in progress (if present)		Indicates it is possible to adjust a parameter using buttons 11 and 12
	Request for DHW	000:000	Describes current status
	Request for Heating		Anomaly or Fault
	Reset/escape to previous screen		Solar active
	Displays room temp. and numerical date		External probe connected
	Functioning in wireless mode (RF models only)		Battery condition low (RF models only)

7. Climatic RF Boiler Communication

The communication between the remote and the boiler mounted receiver is identified with the symbol. 

There are three possible conditions shown via this symbol:

1. Symbol not present - No compatible connection between devices.
2. Symbol flashing - Connection with communication error
3. Symbol permanent - Communication OK

8. Programming

a. Set Time

Turn the mode selection switch to CH/DHW on .

Press the **PROG**  button to enter the time setting mode, then press **OK** and the hour will flash.

Using the +/- buttons adjust the time to the correct hour then press **OK**, the minutes will now flash, using the +/- buttons adjust the minutes then press **OK**. The day of the week will flash, using the +/- buttons set to the correct day of the week and press **OK** then **ESC** to get back to main menu.

b. Set Heating Programme

Press the **PROG**  button and **TIME** will appear, press + and **CH PRG** will flash, press **OK** and **MONDAY** will appear.

Using the + button you can programme individual days or blocks of days then press **OK**.

On 1 will be displayed and the time will flash, using the +/- buttons you can select the time you wish the heating to turn on followed by **OK**, then using the +/- buttons you can set the time you wish the heating to turn off. Press **OK** and the next on period will appear, repeat the previous procedure for the next on-off periods for the rest of the day to a maximum of four on periods. After one minute the display will return to main menu or keep pressing **ESC**.

NOTE: if four on / off periods are not required then set the unused periods on off times the same.

E.g. on 23:00 off 23:00.

c. Set Hot Water Programme



Note; The hot water programmes only need to be set when a hot water storage cylinder is present.



Press the **PROG**  button and TIME will appear, press + twice and HW PRG will flash, press **OK** and MONDAY will appear. Using the + button you can programme individual days or blocks of days then press **OK**. On 1 will flash on the display with a time below it, using the +/- buttons you can select the time you wish the hot water to turn on followed by **OK**, then using the +/- buttons you can set the time you wish the hot water to turn off. Press **OK** and the next on period will appear, repeat the previous procedure for the next on-off periods for the rest of the day to a maximum of four on periods. After one minute the display will return to main menu or keep pressing **ESC**.

NOTE: if four on off periods are not required then set the unused periods on off times the same.
E.g. On 23:00 off 23:00.

d. Setting the Temperature





Note; There are two temperature settings, comfort which is the heating on setting and economy which is the heating off setting. The comfort temperature is the room temperature required during the heating on period. The economy temperature is the minimum allowable room temperature, e.g. if the economy temperature is set to 10°C and the temperature drops below this during a heating off period the boiler will switch on to maintain the 10°C setting.

Press the  button and the word COMFOR will appear with the temperature flashing above and a  symbol. Using the +/- buttons set the temperature as required then press **OK** to store.

Press the  button twice and the word ECONOM will appear with the temperature flashing above and a  symbol. Using the +/- buttons set the temperature as required then press **OK** to store.

9. a. Mode Selection

The mode selection switch (1) has five settings.

- a.  In this mode the control is switched off but the boiler frost protection is still active.
- b.  In this mode the control is switched off but provides frost protection for its immediate location.
- c.  This mode provides hot water only (summer setting).
- d.  This mode provides hot water and timed and temperature controlled heating (winter setting).
- e.  This mode is used in conjunction with an air conditioning unit to provide summer cooling control.(Hot Water is also active)

b. Central Heating Temperature setting (8)

The central heating temperature setting adjusts the primary heating water temperature to the user's requirement. When the dial is turned the temperature setting is displayed on the screen.

The primary flow temperature might not reach the temperature set by the user when in operation because the programmer will control the boiler output to give optimum performance to reach the required room temperature setting.



c. Domestic Hot Water Temperature Setting (7)

The domestic hot water temperature setting adjusts the temperature of the water delivered to the hot tap to the user's requirement. When the dial is turned the temperature setting is displayed on the screen.

d. Continuous Override

The override function is used to manually control the boiler, press the **AUTO**  button and use the +/- buttons to set the desired room temperature. To turn off the manual override press the **AUTO**  button.

e. Temporary Override

To access Temporary override press the +/- buttons to set the desired temperature and the  symbol will flash in the top right hand corner of the display. The room temperature will be maintained until the next timed on or off period or press the **AUTO**  button to come out of temporary override.

f. Room Frost Protection

If the temperature in the room where the programmer is installed drops to 5°C the boiler will operate at minimum heating output until the room temperature has been raised to 5.6°C.

g. External Probe (optional)

If an external temperature probe is fitted it is possible to set a flow temperature correction curve according to the outside temperature. By turning the CH temperature dial you can scroll from 0 to 9, each number corresponds to a line on the graph. Each number corresponds to a line on the graph in fig 5. e.g. line 6 will give a flow temperature of 60°C when the external temperature is 10°C.

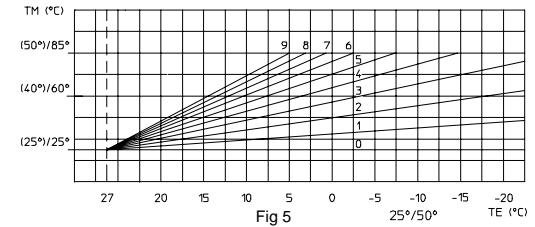



Fig 5
TE = External Temperature
TM = Heating Flow Temperature (values in brackets are for Low Temp Circuits)

h. Cooling Mode

In this mode the programmer can be used to control an air-conditioning unit, turn the selector to  to enable.

NOTE; to use this function some boilers will need to have a relay PCB kit added. For more information please contact Alpha Heating Innovation.
If fitted; the cooling programming for time and temperature is the same as for heating with the selector 1 (fig 4) in the cooling position.

i. Information

Pressing the **INFO** button allows the user to scroll through a menu showing various temperatures and the functioning state of the programmer.

With each press of the **INFO** button a value will be displayed e.g. DHW T 50°C, if a value is not present a "- -" will be displayed. The display of the **INFO** is subject to the boiler model and the method of connection of the programmer.
To get return to the main menu press **ESC** button or wait for 60 seconds.

The displayed parameters are as follows;

EXT T: External temperature (if external probe is fitted).

HF TMP: Primary flow temperature.

HR TMP: Primary return temperature.

DWIN T: DHW input temperature.

DHW T: DHW output temperature.

PAN T: Solar collector temperature.

CH PRS: Primary system pressure.

SERVIC: Days remaining before a boiler service is required.

VER "X": "X" identifies the type of communication protocol with the boiler in use:

VER PI = IMG-Bus.

The display shows the software version of the programmer remote control.

ZONE: Not used on the model.

j. Faults Diagnostics and Errors

The Climatic remote control continually controls the functioning of the boiler and signals any anomalies, stating the corresponding error code on the display.
The error codes are listed in the boiler installation manual.

If a fault occurs it will be displayed as "ERR-XX" where the "XX" represents a number that identifies the code as well as a flashing  symbol.

The climatic also checks its own functioning state, indicating any malfunction.

Code	Description
ERR>CM (Climatic Display)	Communication error between the Alpha Climatic remote controller or receiver and the boiler.
ERR>TP (Climatic Display)	Error in reading the room temperature or value measured off scale (below 0°C or over 50°C)
E51 (Boiler display)	Communication error between the Alpha Climatic remote controller and receiver. (Climatic RF only)

k. Reset Errors

In the event of a resettable boiler lock out **RESET** will flash on the display. By pressing and holding the reset button (ref 2 fig 4) for 5 seconds, it is possible to reset the boiler.
It is possible to reset the boiler up to 5 times then one hour must elapse until one more attempts can be made.

l. Reset Climatic Remote Control

By pressing the reset button (ref 4 fig 4) the climatic remote control hardware can be reset without losing the user setting, such as time, date and timed programmes.

m. Special Functions

By pressing the **MENU** button, a list of options can be accessed, by pressing the +/- buttons you can scroll through the various options and to select press **OK**.

n. Language

Allows the user to choose between Italian and English.

o. Regult (management of regulation parameters)

This allows you to customise the functioning parameters.

CH MIN allows adjustment of the minimum central heating flow temperature. This value is used to calculate the curves used for the external probe. Values that are too high can cause flow temperatures that are too high on average for room central heating.

OFFSET (regulation constant), constant that can be regulated from -15°C to +15°C and which in the presence of the optional external probe modifies the set flow temperature (see fig 5) set as standard at 0°C.

NOTE; if the self leaning function is enabled the offset value could be modified automatically.

BUILD (dimension and build inertia), adjustable from 1 to 20, default setting is 10. It establishes the reaction speed of the system depending on the type of system present.

Example:

Value	System Type
5	System with little heat inertia e.g. Fan Assisted Radiators
10	System with normal inertia e.g. Standard Radiator system
15	System with high heat inertia e.g. Under-floor Heating

AUTO A (self learning), defines the activation of self learning, as per standard set at OFF. This function allows the Climatic remote control to vary the offset, adapting it to the room in which it is installed.

p. Holiday Mode

During winter mode function it is possible to deactivate both the hot water and central heating for a defined number of days (1 to 99). When the set number of days has past normal function will resume.

When the holiday mode is set a flashing  will be displayed and the number of days it is enabled for.

To set the holiday mode press **OK** then the + button until HOLIDAY appears then **OK** to accept. **Off** will be displayed and by pressing the + button the number of days can be set, press **OK** then **ESC** once to get to main menu and the  symbol and set number of days will flash at the bottom of the screen.

This function can be deactivated by pressing the **AUTO**  button.

In the event of remote telephone activation the Climatic controller will revert back to normal operation omitting the holiday program.

NOTE; the frost protection function is still active during holiday mode.

q. Legion (anti-Legionella function)

The anti-Legionella function raises the temperature of the hot water storage cylinder to the maximum boiler set temperature for 20 minutes to kill Legionella bacteria.

It is possible to set this function once a day at 2am (ON 24H), every Monday at 2am (ON 7 DAYS) or deactivate it (OFF standard function).

NOTE; this function must only be activated when a cylinder is present and a thermostatically controlled blending valve should be fitted to the cylinder hot water outlet.

10. Technical Characteristics:

a. Alpha Climatic HW

- Dimensions (LxHxD):..... 142 x 103 x 31
- Power Supply:.....18V nominal via twin-wire communication Bus
- IMG_BUS protocol maximum power supply voltage:18 Vdc.
- IMG_BUS protocol maximum input:.....23 mA - 250 mW.
- Functioning room temperature:..... 0 - +40°C
- Warehouse temperature:.....-10 - +50°C
- Protection rating according to EN 60730:..... II
- Protection rating according to EN 60529:.....IP 20
- Connection technique:..... 2 polarised wires
- Load reserve time:.....8 hours for hourly count (with at least 2 hours of charge)
- Connection cable max. length:..... 50 m (with cable of 2x0.75mm²) (0.5 -mm² min - 1.5 mm² max)
- Precision indication room temp.:.....+/- 0.5°C a 25°C*
- NTC room temp. sensor:......50 k at 25°C
- Clock indication diversion..... +/- 15 minutes/year

* = the indication of the room temperature can be affected by the point of installation of the remote control (e.g. hot wall, cold wall, height from the ground, etc.)

b. Alpha Climatic RF

Receiver Data:

- Base Power Supply:.....18V nominal via Twin-wire communication bus
- RF communication:..... backbone 868,4 MHz, GFSK modulation, cover 30-100 m (depending on the environment)
- IMG_BUS protocol maximum power supply voltage:.....18 Vdc.
- IMG_BUS protocol maximum input:..... 23 mA - 250 mW.
- Power and duty cycle:.....Power Tx < 10 dBm, duty cycle < 0.1%in one hour (in normal functioning mode)
- Connection technique:.....2 non-polarised wires
- Connection cable (supplied):.....280 mm (with cable of 2x0.35mm2)

Controller Data:

- Dimensions (LxHxD):..... 142 x 103 x 31
- Power Supply:.....2 x 1.5 V, AA batteries
- Functioning room temperature:..... 0 - +40°C
- Warehouse temperature:.....-10 - +50°C
- Protection rating according to EN 60730:..... II
- Protection rating according to EN 60529:.....IP 20
- Precision indication room temp.:.....+/- 0.5°C a 25°C*
- NTC room temp. sensor:.....50 k at 25°C
- Clock indication diversion..... +/- 15 minutes/year

* = the indication of the room temperature can be affected by the point of installation of the Alpha Climatic remote control (e.g. hot wall, cold wall, height from the ground, etc.)

c. Factory Settings

- Central Heating Comfort Temperature 20.0 °C
- Central Heating Economy Temperature16.0 °C
- Cooling Comfort Temperature25 °C
- Cooling Economy Temperature 40 °C
- Room Temperature in Manual20 °C
- Anti Freeze5.0 °C
- Holiday Program..... HOLIDY = OFF
- OffsetOFFSET = 0 °C
- Building InertiaBUILD = 10
- Self LearningAUTO A = OFF
- Room Probe..... AMB = ON
- Reading Correction..... AMB CR = 0.0 °C
- ReductionREDUCT = OFF
- ModulationMODUL = ON
- Telephone ControlREMOTE = ON
- Anti-Legionella..... LEGION = OFF

Alpha
HEATING INNOVATION

Alpha Therm Limited.
Nepicar House, London Road, Wrotham Heath,
Sevenoaks, Kent TN15 7RS
Tel: 0844 871 8764
Email: info@alpha-innovation.co.uk
Website: www.alpha-innovation.co.uk

These instructions have been carefully prepared but we reserve the right to alter the specification at any time in the interest of product improvement.
© Alpha Therm Limited 2011.

Doc No 1.031200 Rev 15.035774/001