

---

# *Excalibur 80*

# *Excalibur 100*

Users Guide

Installation and Servicing Instructions

G.C. Number **47-116-30**

G.C. Number **47-116-31**

Manufactured by **Merloni TermoSanitari spa** - Italy



2000022299983185500020400000000

Country of destination: GB - IE

---

---

# **TABLE OF CONTENTS**

---

---

## **USERS GUIDE**

---

- 1. GENERAL INFORMATION**
- 2. OPERATING INSTRUCTIONS**
- 3. BOILER SHUTDOWN SITUATIONS**
- 4. TIME CLOCK**

## **INSTALLATION AND SERVICING INSTRUCTIONS**

---

### **5. GENERAL INFORMATION**

- 5.1 General Instructions
- 5.2 Overall View

### **6. INSTALLATION**

- 6.1 Reference Standards
- 6.2 Siting the Appliance
- 6.3 Overall Dimensions
- 6.4 Clearances
- 6.5 Mounting the Appliance
- 6.6 Electrical Connection
- 6.7 Gas Connection
- 6.8 Water Connections
- 6.9 Flue Connection
- 6.10 Control Panel
- 6.11 Removing the Front Panel
- 6.12 Fitting the Time Clock
- 6.12 Room Thermostat Connection
- 6.12 Electrical/System Diagrams
- 6.13 Water Circuit Diagram

### **7. COMMISSIONING**

- 7.1 Initial Preparation
- 7.2 Initial Start up
- 7.3 Operational Adjustments
- 7.4 Combustion Analysis
- 7.5 Fume Discharge Monitoring
- 7.6 Boiler Safety Systems
- 7.7 Draining the System
- 7.8 Completion
- 7.9 Operational checks
- 7.10 Instructing the End User

### **8. GAS ADJUSTMENTS**

- 8.1 Changing the Type of Gas
- 8.2 Adjusting the gas pressure

### **9. MAINTENANCE**

#### **10. SERVICING INSTRUCTIONS**

- 10.1 Replacement of Parts
- 10.2 To Gain General Access
  - 10.2.1 Removing the Front Panel
  - 10.2.2 Removing the Sealed Chamber Front Panel
  - 10.2.3 Removing the Side Panels
- 10.3 Access to the Combustion Chamber
  - 10.3.1 Removing the Combustion Chamber
  - 10.3.2 Removing the Burner and Jets
  - 10.3.3 Removing the Electrodes
  - 10.3.4 Removing the Main Heat Exchanger
  - 10.3.5 Removing the Air Pressure Switch
  - 10.3.6 Removing the Fan
- 10.4 Access to the Gas Valve
  - 10.4.1 Removing the Spark Generator
  - 10.4.2 Removing the Gas Valve
- 10.5 Access to the Water Circuit
  - 10.5.1 Removing the Pump Pressure Switch
  - 10.5.2 Removing the Safety Valve
  - 10.5.3 Removing the Automatic Air Vent
  - 10.5.4 Removing the Pump
  - 10.5.5 Removing the Pressure Gauge
  - 10.5.6 Removing the Expansion Vessel
  - 10.5.7 Removing the Overheat Thermostat
  - 10.5.8 Removing the Central Heating Temperature Sensor (N.T.C.)
  - 10.5.9 Removing the D.H.W. Temperature Sensor (N.T.C.)
  - 10.5.10 Removing the D.H.W. Flow Switch
- 10.6 Access to the Control System
  - 10.6.1 Checking the Fuses
  - 10.6.2 Removing the Time Clock
  - 10.6.3 Removing the P.C.B.

#### **11. FAULT FINDING**

- 11.1 Fault Finding Guide (Flow-chart)

#### **12. SHORT SPARE PARTS LIST**

#### **13. TECHNICAL INFORMATION**

# USERS GUIDE

## 1. General Information

This is a combined appliance for the production of central heating (C.H.) and domestic hot water (D.H.W.). This appliance **must be used only** for the purpose for which it is designed. The manufacturer declines all liability for damage caused by improper or negligent use.

**Do not allow** children or inexperienced persons to use the appliance without supervision.

If you smell gas in the room, **do not turn on** light switches, use the telephone or any other object which might cause sparks.

Open doors and windows immediately to ventilate the room.

Shut the gas mains tap (on the gas meter) or the valve of the gas cylinder and call your Gas Supplier immediately.

If you are going away for a long period of time, remember to shut the mains gas tap or the gas cylinder valve.

**Before any intervention within the boiler it is first necessary to cut off the electrical power supply by turning the external switch to "OFF".**

### Control Panel

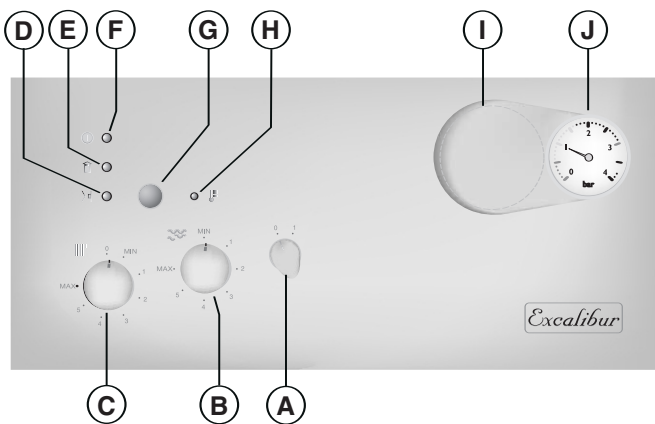

- A - On/Off knob
- B - Domestic Hot Water temperature adjustment knob
- C - Central Heating selection (winter) and temperature adjustment knob
- D - Ignition failure (lockout) L.E.D. (red)
- E - Fume sensor L.E.D. (yellow)
- F - On/Off L.E.D. (green)
- G - Ignition failure (lockout) and/or overheat reset button / *Flue Analysis Modes\**
- H - Overheat L.E.D. (red)
- I - Time clock
- J - Central Heating system pressure gauge

\* **Warning!** the flue analysis mode must only be selected by a qualified service engineer.

## 2. Operating Instructions

**Installation, start-up, adjustments and maintenance must be performed by a competent person only, in accordance with the current Gas Safety (Installation & Use) Regulations and the instructions provided. Improper installation may cause damage or injury to individuals, animals and personal property, for which the manufacturer will not be held liable.**

**To ensure efficient and safe operation it is recommended that the boiler is serviced annually by a competent person.**

**If it is known or suspected that a fault exists on the appliance, it must not be used until the fault has been corrected by a competent person.**

To get the most out of your boiler, we have provided you with some useful advice on proper use and maintenance:

- Periodically check the system pressure using the pressure gauge "J", make sure that the pressure is at 1.5 bar when the system is off and cool. If the pressure is below the minimum recommended value. Consult your installer for checking and refilling the system.
- The outer panels of the units case must only be cleaned with a damp cloth. Do not use abrasive cleaners. The control panel can be wiped with either a damp or dry cloth. Spray polishes must not be used on the control panel surface or knobs. Care must be taken in preventing any liquid entering the appliance.
- If the water is very hard, it is recommended that a water softener be added to the system so as to reduce the formation of limescale in the heat exchanger. This will ensure that the efficiency of the unit remains the same over time, reducing gas consumption and maintenance costs.
- If the boiler should be out of use for a prolonged period, it is recommended that the electrical power supply be disconnected and that the external gas cock be closed. If low temperatures are expected, the boiler and system pipe work should be drained in order to prevent frost damage.
- To improve comfort and take full advantage of the heat produced by the boiler, it is recommended that an external (room) thermostat be installed.
- It is good practice to clean and service the appliance and central heating system every year. Call an Authorised Service Centre.

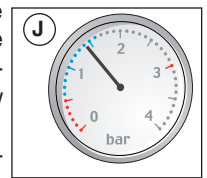

### Ignition Procedure

Turn the selector knob "A" to the "I" position. The green L.E.D. "F" will illuminate indicating that the boiler is ready to operate. The centralised electronic control unit will ignite the burner, without any manual intervention but in response to the request for domestic hot water or heating. If, after approximately 10 seconds, the burner has not ignited, the boiler safety devices will shut off the gas and the red L.E.D. "D" illuminates. To reset the ignition system, the reset "G" must be pressed and released. Should the boiler fail to ignite a second time, check that the external gas cock is open. If the problem persists, contact an Authorised Service Centre.

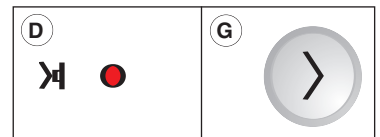
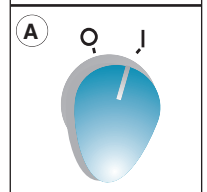
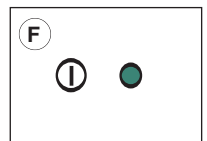

## 3. Boiler Shutdown Situations

### Winter and Summer Operating Modes

In the 'winter' operating mode, the boiler will produce both Central Heating and Domestic Hot Water. In the 'summer' operating mode, the boiler will produce only Domestic Hot Water.

Using the knobs on the control panel, the user can select 'winter' or 'summer' operating mode. Keeping the knob "C" at the "0" position selects the 'summer' operating mode. 'Winter' operating mode may be selected by positioning the knob "C" between the min. and max. settings.

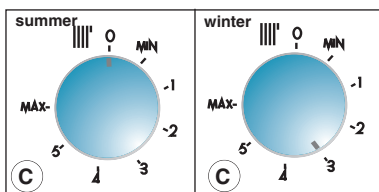

### Adjusting the Heating

It is possible to set the temperature of the heating system by adjusting the knob "C".

By positioning the indicator somewhere between 1 and 9, a temperature may be obtained which varies from approximately 40°C to about 80°C.

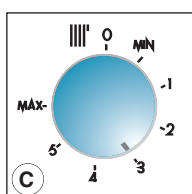

### External (Room) Thermostat Control

If an external (room) thermostat is installed, it is recommended that the temperature of the heating system be set by means of the "C" knob, leaving it at MAX position in order to obtain the best performance from the boiler and to allow the regulation of the external temperature to function efficiently.

### Setting the Hot Water for Domestic Use

Both in the winter and summer mode, the temperature of the domestic hot water may be adjusted by using the "B" knob. A delivery temperature for the water may be chosen in a range from 36°C to about 56°C, depending on the flow rate of the water and the position of the knob between 1 and 9 settings.

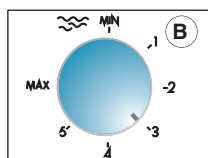

### Turning Off the Central Heating

To turn off the Central Heating, rotate the "C" knob to the "0" position.

The boiler will stay in 'summer' mode, providing Domestic Hot Water on request.

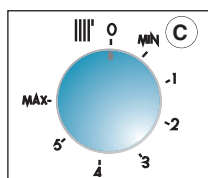

### Turning Off the Boiler

To turn the boiler off, rotate the selector knob "A" to the "0" position (OFF); the respective green L.E.D. "F" will go off. Close the gas cock located under the boiler and turn the electricity supply switch (located outside the boiler) to the OFF position.

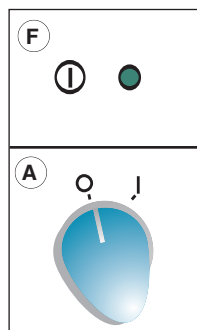

The boiler is equipped with safety devices that intervene in certain situations and shut it off. Most of these situations are communicated by means of the L.E.D.s and at times the user may be able to remedy them.

### Shutdown Due To Ignition Failure

In the event that the automatic ignition of the burner has failed, the red L.E.D. "D" will illuminate. In order to reset the ignition, the button "G" must be pressed and released. Should the boiler fail to ignite a second time, check that the external gas cock is open. If the problem persists, contact an Authorised Service Centre.

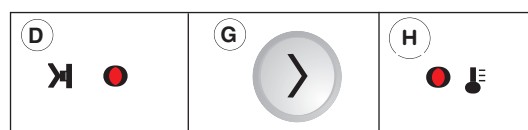

### Shutdown Due To Overheating

In the event that the safety limit is exceeded for the temperature of the water in the boilers exchanger, the thermostat shuts off the boiler and the red L.E.D. "H" illuminates.

To remedy this situation, wait a few minutes to allow the exchanger to cool down, then press and release the reset button "G".

If this situation occurs frequently, contact an Authorised Service Centre.

### Shutdown Due To Insufficient Circulation

If the boiler is off, one possible cause for this state is an insufficient pressure of water in the system.

Check the system pressure on the pressure gauge "J" and if it is less than 0.5 bar, consult your installer for checking and refilling the system.

If the boiler does not start up again, contact an Authorised Service Centre.

If there are frequent drops in pressure within the system, have a plumber check the heating system for possible water leaks.

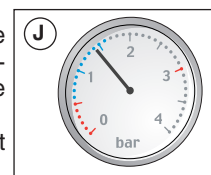

### Temporary Shutdown Due To Defective Discharge of Exhaust Fumes

The boiler is fitted with safety devices, which in the event of a defective discharge of exhaust fumes, automatically interrupts the gas supply, thereby shutting off the boiler.

The shut-off of the boiler is temporary and is indicated by the illumination of the yellow L.E.D. "E" for a period of about 15 minutes.

Once this time period has passed and the discharge state of exhaust fumes has returned to normal, the boiler automatically turns back on.

#### Important!

If this situation occurs frequently, contact an Authorised Service Centre. so that they may check that the exhaust fumes are being expelled correctly and that the area is ventilated properly.

### Anti-frost Device

The boiler is fitted with a device which, in the event that the water temperature falls below 8°C the pump activates and runs until a temperature of 18°C is attained. In the event that the water temperature falls below 3°C, the diverter valve switches to Domestic Hot Water and the burner fires and runs on minimum power until a temperature of 33°C is attained.

This device is only activated when the boiler is operating perfectly and

- the system pressure is sufficient;
- the boiler is powered electrically;
- gas is being distributed.

## 4. Time clock

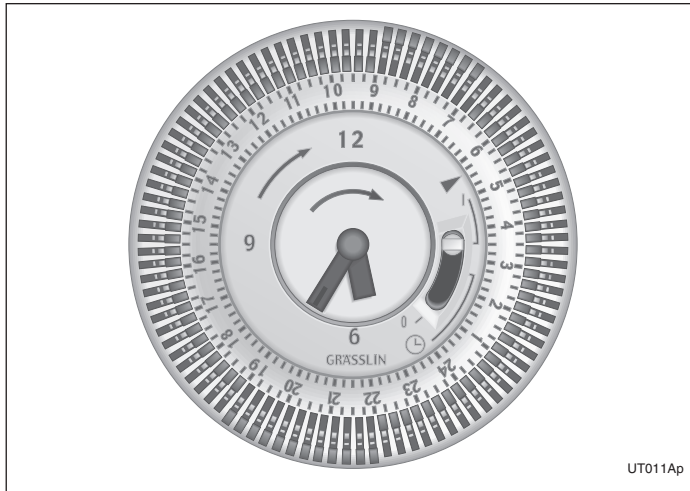

UT011Ap

**Note:** the time clock is for central heating control only.

The time clock is provided with 96 switches, called riders, each of which covers a time interval of 15 minutes (four per hour).

When a rider is switched from the inside (off setting) to the outside of the clock border (on setting), the circuit is closed (switch on) for a period of 15 minutes and then the boiler starts if the room thermostat (if installed) or the heating thermostat require heat (heating function on).

### EXAMPLE

To set the heating of your home in the time interval from 7.00 am to 9.30 am and from 7.00 pm to 10.00 pm every day:

- rotate the outer ring of the clock in a clockwise direction until the correct time of day (24h) lines up with the arrow on the clock (at approx. 2 o'clock position);
- **under no circumstances should the minute hand be moved manually;**
- make sure all the switches, i.e. the riders, are placed on the inside of the clock border;
- pull outward the riders for 7.00 am and 9.30 am, and then all riders between these two;
- repeat this for 7.00 pm and 10.00 pm.

Other heating intervals may be set in the same way.

The timer has approximately 150 hours of battery back up for power failure.

### Technical Data

Ambient temperature:	- 10°C to + 55°C
Running reserve:	150 h (not for 1.5 V DC)
Shortest switching time:	15 minutes
Programmable:	Every 15 minutes

The clock is provided with a selector switch with three positions (see figure):

1. **Position "I" CONSTANT:** in this position, the clock circuit is always closed (switch on), therefore the boiler will constantly be on and will only shut off upon the request of the room thermostat (if installed) or the heating thermostat;

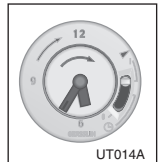

UT014A

2. **Position "O" HEATING OFF:** in this position, the clock circuit is always open (switch off) and the boiler will therefore never ignite for heating;

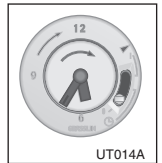

UT014A

3. **"Central" Position PROGRAMMING ACTIVE:** in this position, the programming set by the user is active.

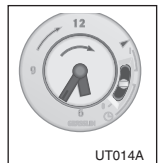

UT014A

---

---

# INSTALLATION AND SERVICING INSTRUCTIONS

---

---

## 5. GENERAL INFORMATION

---

---

### 5.1 General Instructions

This manual is an integral and essential part of the product. It should be kept with the appliance so that it can be consulted by the user and our authorised personnel.

Please carefully read the instructions and notices about the unit contained in this manual, as they provide important information regarding the safe installation, use and maintenance of the product.

For operating instructions please consult the separate Users Manual.

Read the instructions and recommendations in these Installation Instructions carefully to ensure proper installation, use and maintenance of the appliance.

Keep this manual in a safe place. You may need it for your own reference while our Servicing Centre technicians or your installer may need to consult it in the future.

This is a combined appliance for the production of central heating (C.H.) and domestic hot water (D.H.W.).

This appliance **must be used only** for the purpose for which it is designed.

The manufacturer declines all liability for damage caused by improper or negligent use.

No asbestos or other hazardous materials have been used in the fabrication of this product.

**Before connecting** the appliance, check that the information shown on the data plate and the table in section 7 comply with the electric, water and gas mains of the property. You will find the data plate on the reverse of the control panel.

The gas with which this appliance operates is also shown on the label at the bottom of the boiler.

**Do not** install this appliance in a damp environment or close to equipment which spray water or other liquids.

**Do not place** objects on the appliance.

**Do not allow** children or inexperienced persons to use the appliance without supervision.

If you smell gas in the room, **do not turn on** light switches, use the telephone or any other object which might cause sparks.

Open doors and windows immediately to ventilate the room.

Shut the gas mains tap (at or adjacent to the gas meter) or the valve of the gas cylinder and call your Gas Supplier immediately.

If you are going away for a long period of time, remember to shut the mains gas tap or the gas cylinder valve.

**Always disconnect** the appliance either by unplugging it from the mains or turning off the mains switch before cleaning the appliance or carrying out maintenance.

**In the case of faults or failure**, switch off the appliance and turn off the gas tap. Do not tamper with the appliance.

For repairs, call your local Authorised Servicing Centre and request the use of original spare parts. For in-guarantee repairs contact MTS (GB) Limited.

**Check** the following at least once a year:

- 1 - Check the seals for the water connections; replace any faulty seals.
- 2 - Check the gas seals; replace any faulty gas seals.
- 3 - Visual check of the entire unit.
- 4 - Visual check of the combustion process or analysis of combustion by-products (see section 3.6) and cleaning of the burner if needed.
- 5 - If called for by point. 3, dismantling and cleaning of the combustion chamber.
- 6 - If called for by point. 4, dismantling and cleaning of the burner jets.
- 7 - Visual check of the primary heat exchanger:
  - check for overheating in the blade assembly;
  - clean the exhaust fan if needed.
- 8 - Adjustment of the flow rate of the gas: flow rate for lighting, partial load and full load.
- 9 - Check of the heating safety systems:
  - safety device for maximum temperature (overheat thermostat);
  - safety device for maximum pressure (safety valve).
- 10- Check of the gas safety systems:
  - safety device for lack of gas or flame ionisation (detection electrode);
  - safety device for gas cock.
- 11- Check of the electrical connection (make sure it complies with the instructions in the manual).
- 12- Check of domestic hot water production efficiency (flow rate and temperature)
- 13- General check of the combustion by-products of the discharge/ventilation system.
- 14- Check of the general performance of the unit.

## General Information

### 5.2 Overall View

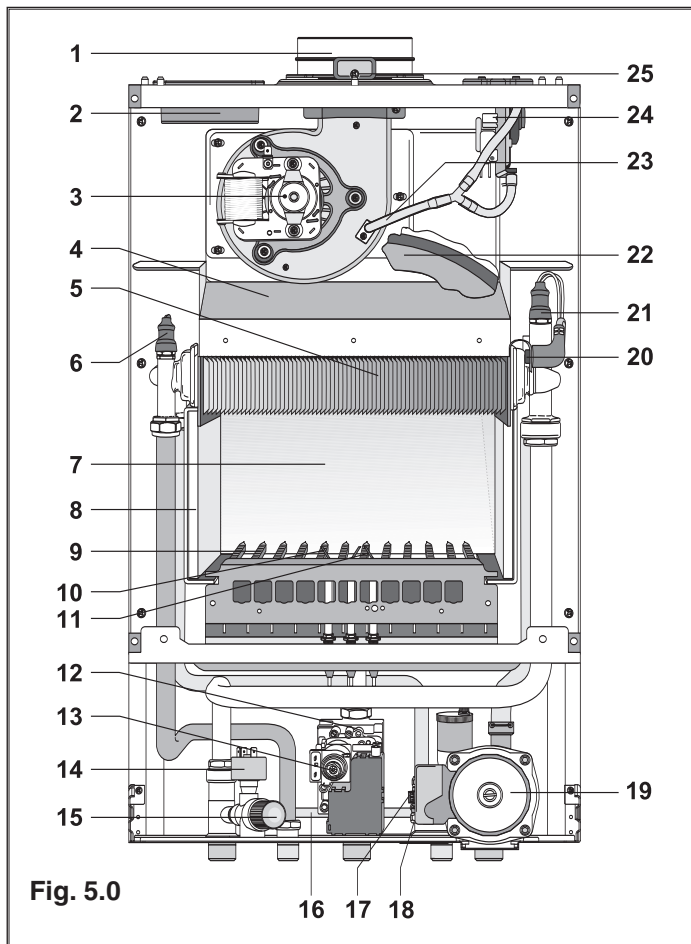

#### Legend:

1. Flue connector
2. Air intake for twin pipe flue systems
3. Fan
4. Combustion chamber hood
5. "Twin-pass" heat exchanger
6. Domestic hot water temperature probe
7. Combustion chamber
8. Combustion chamber insulation panel
9. Burner
10. Detection electrode
11. Ignition electrodes
12. Gas valve
13. Spark generator
14. Low water pressure switch
15. Safety valve (3 bar)
16. Automatic By-pass
17. D.H.W. Flow switch
18. Domestic hot water inlet filter
19. Circulation pump with automatic air release valve
20. Safety thermostat
21. Main circuit temperature probe
22. Expansion vessel
23. Air pressure switch tube
24. Air pressure switch
25. Combustion analysis points

---

## 6. INSTALLATION

---

### 6.1 Reference Standards

The technical information and instructions provided herein below are intended for the installer / Servicing Technician so that the unit may be installed and serviced correctly and safely.

In the United Kingdom the installation and initial start up of the boiler must be by a CORGI Registered Installer in accordance with the installation standards currently in effect, as well as with any and all local health and safety standards i.e. CORGI.

In the Republic of Ireland the installation and initial start up of the appliance must be carried out by a Competent Person in accordance with the current edition of I.S.813 "Domestic Gas Installations", the current Building Regulations, reference should also be made to the current ETCI rules for electrical installation.

**This appliance must be installed by a competent installer in accordance with current Gas Safety (installation & use) Regulations.**

The installation of this appliance must be in accordance with the relevant requirements of the Local Building Regulations, the current I.E.E. Wiring Regulations, the bylaws of the local water authority, in Scotland, in accordance with the Building Standards (Scotland) Regulation and Health and Safety document No. 635 "Electricity at work regulations 1989" and in the Republic of Ireland with the current edition of I.S. 813, the Local Building Regulations (IE).

#### C.O.S.H.H.

Materials used in the manufacture of this appliance are non-hazardous and no special precautions are required when servicing. Installation should also comply with the following British Standard Codes of Practice

<b>BS 7593:1992</b>	<b>Treatment of water in domestic hot water central heating systems</b>
<b>BS 5546:1990</b>	<b>Installation of hot water supplies for domestic purposes</b>
<b>BS 5440-1:2000</b>	<b>Flues</b>
<b>BS 5440-2:2000</b>	<b>Air supply</b>
<b>BS 5449:1990</b>	<b>Forced circulation hot water systems</b>
<b>BS 6798:1987</b>	<b>Installation of gas fired hot water boilers of rated input not exceeding 60kW</b>
<b>BS 6891:1989</b>	<b>Installation of low pressure gas pipe up to 28mm</b>
<b>BS 7671:2001</b>	<b>IEE wiring regulations</b>
<b>BS 4814:1990</b>	<b>Specification for expansion vessels</b>
<b>BS 5482:1994</b>	<b>Installation of L.P.G.</b>

The appliance may be installed in any room or indoor area,

### 6.2 Siting the Appliance

although particular attention is drawn to the requirements of the current I.E.E. Wiring Regulations, and in Scotland, the electrical provisions of the Building Regulations applicable in Scotland, with respect to the installation of the combined appliance in a room containing a bath or shower, the location of the boiler in a room containing a bath or shower should only be considered if there is no alternative.

**Where a room-sealed appliance is installed in a room containing a bath or shower the appliance and any electrical switch or appliance control, utilising mains electricity should be situated so that it cannot be touched by a person using the bath or shower, specifically in accordance with current IEE Wiring Regulations.**

The location must permit adequate space for servicing and air circulation around the appliance as indicated in Section 6.4. The location must permit the provision of an adequate flue and termination.

For unusual locations special procedures may be necessary.

BS 6798-1987 gives detailed guidance on this aspect.

A compartment used to enclose the appliance must be designed specifically for this purpose. No specific ventilation requirements are needed for the installation within a cupboard.

This appliance is not suitable for outdoor installation.

***The type C appliances (in which the combustion circuit, air vent intake and combustion chamber are air-tight with respect to the room in which the appliance is installed) can be installed in any type of room.***

Secondary ventilation is not required with this boiler. The boiler must be installed on a solid, non-combustible, permanent wall to prevent access from the rear.



# Installation

## 6.3 Overall Dimensions

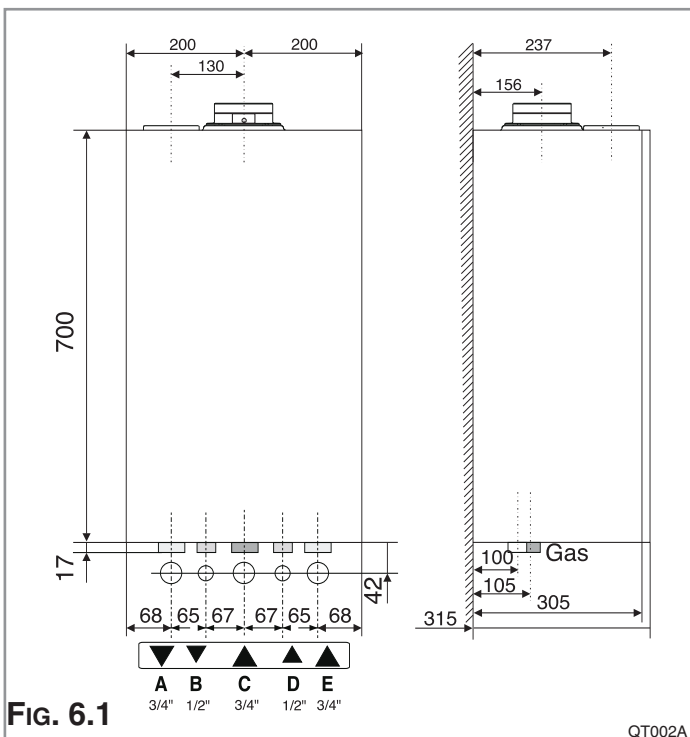

### Legend:

- A = Central Heating Flow (3/4")
- B = Domestic Hot Water Outlet (1/2")
- C = Gas Inlet (3/4")
- D = Domestic Cold Water Inlet (1/2")
- E = Central Heating Return (3/4")

## 6.4 Clearances

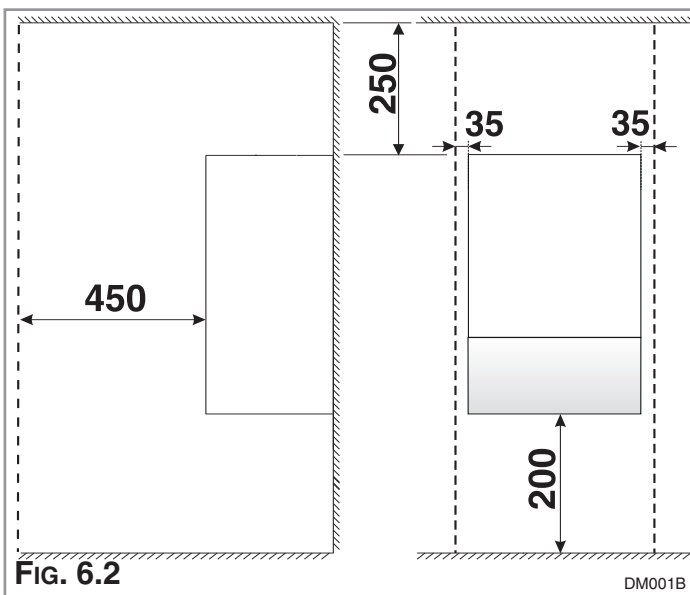

In order to allow access to the interior of the boiler for maintenance purposes, the boiler must be installed in compliance with the minimum clearances indicated in **Fig. 6.2**

## 6.5 MOUNTING THE APPLIANCE

After removing the boiler from its packaging, remove the template from the separate box containing the connection kit.

**Note:** Pay particular attention to any test water that may spill from the appliance.

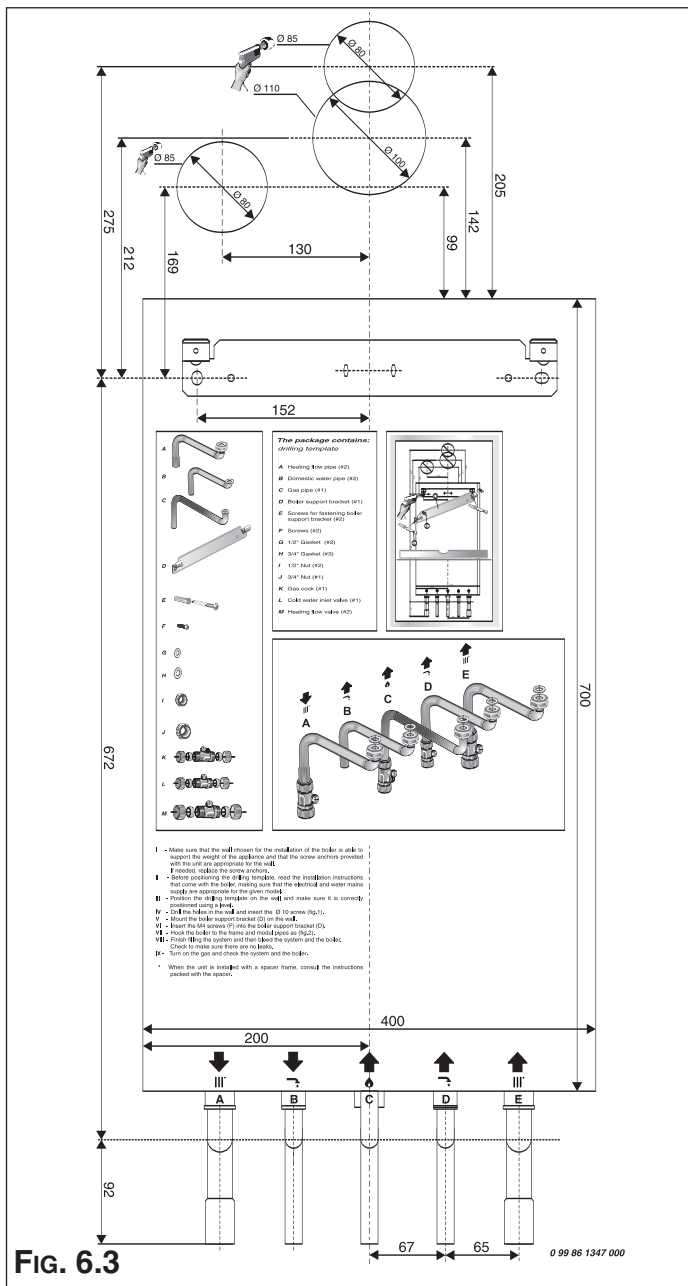

Place the template in the position the appliance is to be mounted and after ensuring it is hanging squarely, use it to drill the holes for the hanging bracket and flue pipe(s) **NB:** For further information relating to the flue installation please refer to Section 6.9 Flue Connection. (If the appliance is to be fitted on a wall of combustible material, the wall **must** be protected by a sheet of fire-proof material).

If the appliance is to be fitted into a timber framed building, guidance should be sought from the IGE document REF: IGE/UP/7.i

# Installation

**2.5.1.** Drill the wall and plug using those supplied with the connections kit, position the bracket and secure with the wall bolts supplied. **Note:** It is highly recommended that a spirit level be used to position the appliance to ensure that it is perfectly level.

**2.5.2.** Position the appliance on the hanging bracket and connect the isolating valves supplied in the connection kit as shown on the wall template (see also Sections 6.7 Gas Connections, 6.8 Water Connections & Fig. 6.3).

## 6.6 Electrical Connection

For safety purposes, have a competent person carefully check the electrical system in the property, as the manufacturer will not be held liable for damage caused by the failure to earth the appliance properly or by anomalies in the supply of power. Make sure that the residential electrical system is adequate for the maximum power absorbed by the unit, which is indicated on the rating plate. In addition, check that the section of cabling is appropriate for the power absorbed by the boiler.

The boiler operates with alternating current, as indicated in the Technical Information table in Section 13, where the maximum absorbed power is also indicated. Make sure that the connections for the neutral and live wires correspond to the indications in the diagram. The appliance electrical connections are situated on the reverse of the control panel.

### **IMPORTANT!**

In the event that the power supply cord must be changed, replace it with one with the same specifications.

**Note:** The diagrams for the electrical system are indicated in section 6.13.

### **Warning, this appliance must be earthed.**

External wiring to the appliance must be carried out by a competent person and be in accordance with the current I.E.E. Regulations and applicable local regulations.

The appliance is supplied with a fly-lead already connected, this must be connected to a 240v supply fused at 3A and must facilitate complete electrical isolation of the appliance, by the use of a fused double pole isolator having a contact separation of at least 3 mm in all poles or alternatively, by means of a 3 A fused three pin plug and unswitched shuttered socket outlet both complying with BS 1363.

The point of connection to the Electricity supply must be readily accessible and adjacent to the appliance unless the appliance is installed in a bathroom when this must be sited outside the bathroom (see section 6.2).

Should external controls be required, the design of the external electrical circuits should be undertaken by a competent person, see section 6.12 for further information.

## 6.7 Gas Connection

The local gas region contractor connects the gas meter to the service pipe.

If the gas supply for the boiler serves other appliances ensure that an adequate supply is available both to the boiler and the other appliances when they are in use at the same time.

Pipe work must be of an adequate size. Pipes of a smaller size than the boiler inlet connection should not be used.

## 6.8 Water Connections

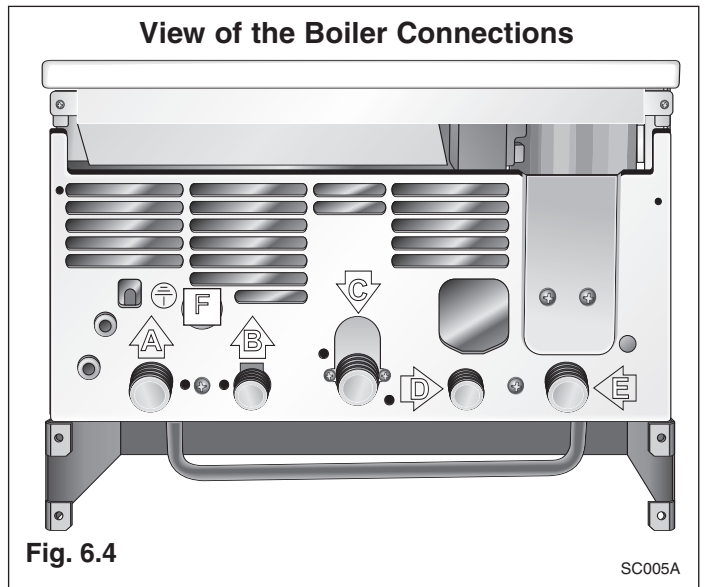

### **Legend:**

- A = Central Heating Flow
- B = Domestic Hot Water Outlet
- C = Gas Inlet
- D = Domestic Cold Water Inlet
- E = Central Heating Return
- F = Safety Valve Outlet

### **Pipe Work:**

Copper tubing to BS EN 1057:1996 is recommended for water pipes. Jointing should be either with capillary soldered or compression fittings.

Where possible pipes should have a gradient to ensure air is carried naturally to air release points and water flows naturally to drain taps.

The appliance has a built-in automatic air release valve, however it should be ensured as far as possible that the appliance heat exchanger is not a natural collecting point for air.

Except where providing useful heat, pipes should be insulated to prevent heat loss and avoid freezing.

Particular attention should be paid to pipes passing through ventilated spaces in roofs and under floors.

### **By-pass:**

The appliance includes an automatic by-pass valve, which protects the main heat exchanger in case of reduced or interrupted water circulation through the heating system, due to the closing of thermostatic valves or radiators.

### **SYSTEM DESIGN:**

This boiler is suitable only for sealed systems.

# Installation

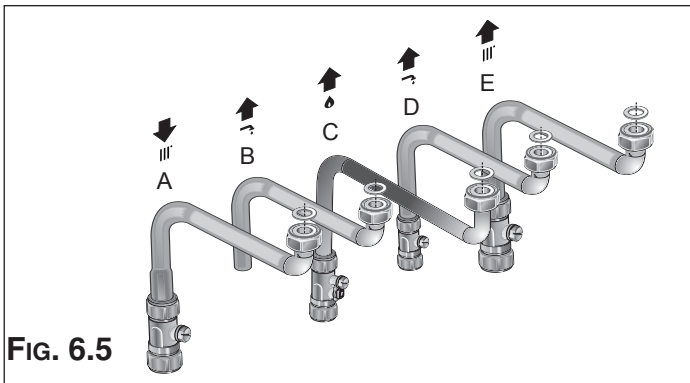

**FIG. 6.5**

**Drain Cocks:**

These must be located in accessible positions to permit the draining of the whole system and should be fitted at all low points. The taps must be at least 15mm nominal size and manufactured in accordance with BS 2870:1980.

**Safety Valve Discharge:**

The discharge should terminate facing downward on the exterior of the building in a position where discharging (possibly boiling water & steam) will not create danger or nuisance, but in an easily visible position, and not cause damage to electrical components and wiring.

The discharge must not be over an entrance or a window or any other type of public access.

**Air Release Points:**

These must be fitted at all high points where air naturally collects and must be sited to facilitate complete filling of the system.

The appliance has an integral sealed expansion vessel to accommodate the increase of water volume when the system is heated. It can accept up to 6 litres (1.3 gal) of expansion water. If the heating circuit has an unusually high water content, calculate the total expansion and add an additional sealed expansion vessel with adequate capacity. This should be located on the return pipe work as close as possible to the pump inlet.

**Mains Water Feed - Central Heating:**

There must be no direct connection to the mains water supply even through a non-return valve, without the approval of the Local Water Authority, therefore a temporary method for initially filling the system and replacing lost water during servicing in accordance with current Water Regulations and bylaws must be provided (Fig. 6.6).

**Note:** The installer should ensure that there are no leaks as fre-

quent filling of the heating system can lead to premature scaling of the main exchanger and failure of hydraulic components.

**Domestic Water:**

The domestic water must be in accordance with the relevant recommendation of BS 5546:1990. Copper tubing to BS EN 1057:1996 is recommended for water carrying pipe work and must be used for pipe work carrying drinking water, a scale reducer should also be used to reduce the risk of scale forming in the domestic side of the heat exchanger.

**CENTRAL HEATING**

Detailed recommendations are given in BS 6798:1987 and BS 5449-1:1990, the following notes are given for general guidance.

## Residual Head of the Boiler

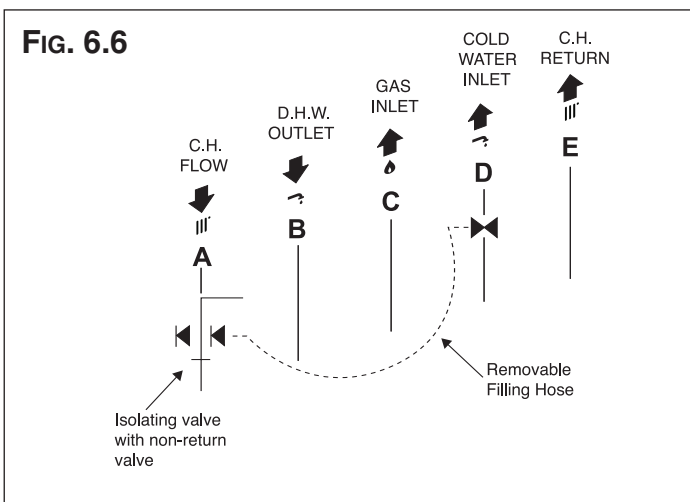
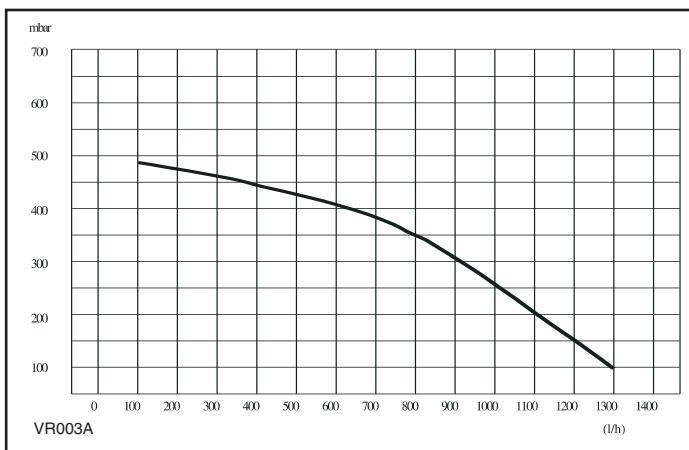

**FIG. 6.6**

# Installation

## 6.9 Flue Connections

### FLUE SYSTEM

The provision for satisfactory flue termination must be made in accordance with BS 5440-1.

The appliance must be installed so that the flue terminal is exposed to outside air.

The terminal must not discharge into another room or space such as an outhouse or lean-to.

It is important that the position of the terminal allows a free passage of air across it at all times.

The terminal should be located with due regard for the damage or discolouration that might occur on buildings in the vicinity and consideration must be given to adjacent boundaries.

In cold or humid weather water vapour may condense on leaving the flue terminal. The effect of such "plumbing" must be considered.

If the terminal is less than 2 metres above a balcony, above ground or above a flat roof to which people have access, then a suitable terminal guard must be fitted. When ordering a terminal guard, quote the appliance model number.

A suitable terminal guard is available from:

### TOWER FLUE COMPONENTS

Morley Road  
Tonbridge  
Kent TN9 1RA

The minimum acceptable spacing from the terminal to obstructions and ventilation openings are specified in **Fig. 6.7**.

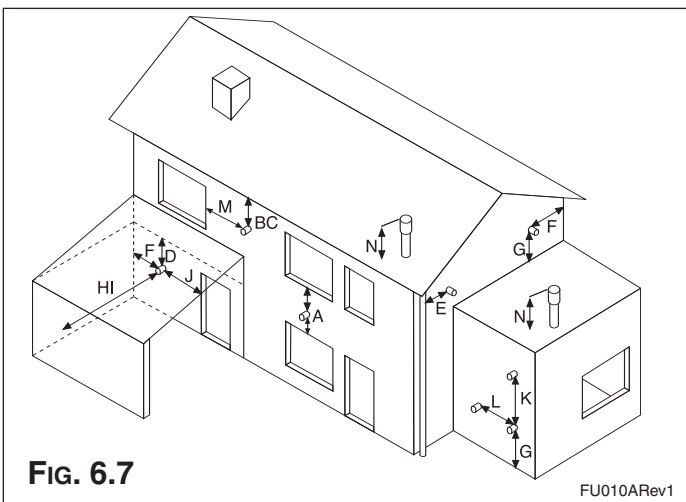

TERMINAL POSITION	mm
A - Directly below an openable window or other opening	300
B - Below gutters, solid pipes or drain pipes	75
C - Below eaves	200
D - Below balconies or car-port roof	200
E - From vertical drain pipes and soil pipes	150
F - From internal or external corners	300
G - Above ground or balcony level	300
H - From a surface facing a terminal	600
I - From a terminal facing a terminal	1200
J - From an opening in the car port (e.g. door, window) into dwelling	1200
K - Vertically from a terminal in the same wall	1500
L - Horizontally from a terminal in the same wall	300
M - Horizontally from an opening window	300
N - Fixed by vertical flue terminal	

**NOTE: THE FLUE MUST NOT TERMINATE IN A PLACE LIKELY TO CAUSE NUISANCE**

### IMPORTANT!

For all flue systems, a restrictor may need to be inserted into the exhaust manifold, the size of the restrictor and details of fitting requirements are shown in Table 6.1 (Page 18).

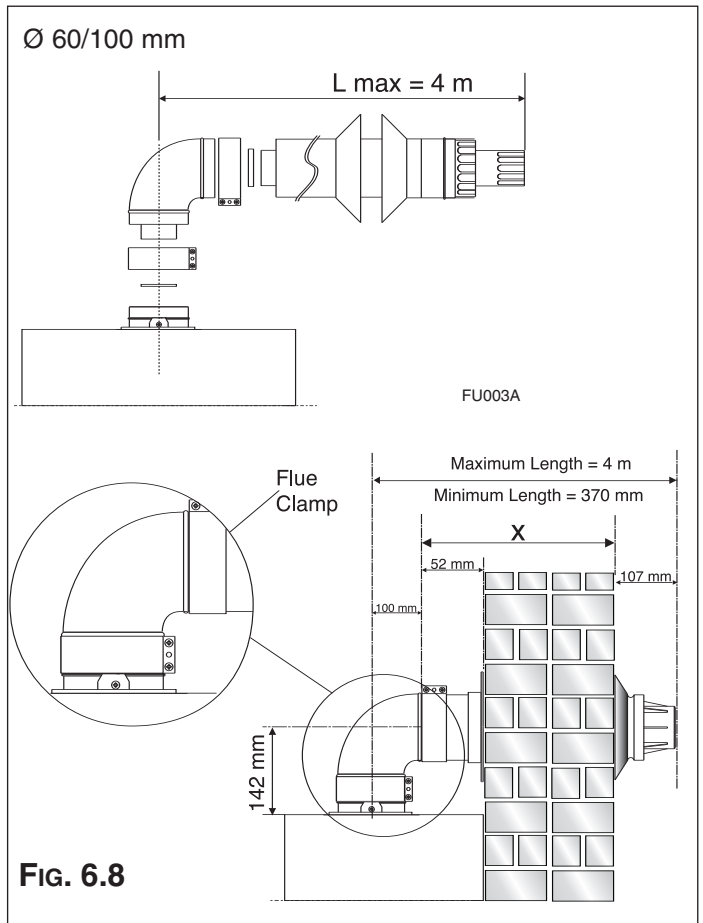

### Fitting the Coaxial Flue (Horizontal)

(For Telescopic Instructions see page 13 and for Vertical Flue and Twin Pipe Instructions see page 14)

#### CONTENTS:

- 1x SILICONE O-RING (60mm)
- 1x ELBOW (90°)
- 2x WALL SEALS (INTERNAL & EXTERNAL)
- 1x ALUMINIUM FLUE PIPE INCLUDING TERMINAL (1 METRE - 60/100)
- 2x FLUE CLAMPS
- 8x SCREWS
- 2x SEALS

Once the boiler has been positioned on the wall, insert the elbow into the socket (**Fig 6.8**) and rotate to the required position. NOTE: It is possible to rotate the elbow 360° on its vertical axis.

Using the flue clamps, seals and screws supplied (**Fig 6.8**) secure the elbow to the boiler.

The 1 metre horizontal flue kit (705958) supplied is suitable for an exact **X dimension** of 823mm, and the 750mm horizontal flue kit (705785) is suitable for an exact **X dimension** of 573mm.

Measure the distance from the face of the external wall to the

# Installation

face of the flue elbow (**X - Fig 6.8**), add 22 mm to this measurement, you now have the total length of flue required (including the terminal), this figure must now be subtracted from 860mm, you now have the total amount to be cut from the plain end of the flue.

Cut the flue to the required length ensuring that the distance between the inner and the outer flue is maintained (**Fig 6.10**).

e.g.  $X = 508\text{mm} + 22\text{mm} = 530\text{mm}$

$860 - 530 = 330\text{mm}$  (Length to be cut from the plain end of the flue).

Once cut to the required length, ensure that the flue is free from burrs and reassemble the flue. If fitting the flue from inside of the building attach the grey outer wall seal to the flue terminal and push through the flue through the hole, once the wall seal has passed through the hole, pull the flue back until the seal is flush with the wall. Alternatively, the flue can be installed from outside of the building, the grey outer seal being fitted last.

## Fitting the Telescopic Flue Kit (Horizontal)

### CONTENTS:

1x SILICONE O-RING (60mm)

1x ELBOW (90°)

2x WALL SEALS (INTERNAL & EXTERNAL)

1x ALUMINIUM FLUE PIPE INCLUDING TERMINAL (TELESCOPIC - 60/100)

2x FLUE CLAMPS

8x SCREWS

2x SEALS

The telescopic flue is suitable for use with an exact minimum **X dimension** of 270mm and an exact maximum **X dimension** 470mm.

### IMPORTANT!!

**Do not extend the telescopic flue to an X dimension of more than 470mm. If longer lengths are required use extension pieces as necessary. Under no circumstances must the flue be cut.**

The wall must then be made good around the flue (ensuring a fall of 1° is maintained away from the boiler to the flue terminal).

Once made good, place the inner (white) wall seal over the flue and push up to the wall, secure the flue to the elbow by using the clamp supplied.

For each additional 90° elbow 1 metre must be removed from the total flue length (maximum 4 metres including the 1st elbow). For each additional 45° elbow 0.5 metre must be subtracted from the total flue length (**Fig 6.13**).

## Fitting the Coaxial Flue (Vertical)

(For Twin Pipe Instructions see page 14)

### CONTENTS:

1x SILICONE O-RING (60mm)

1x ELBOW (90°)

2x WALL SEALS (INTERNAL & EXTERNAL)

1x ALUMINIUM FLUE PIPE INCLUDING TERMINAL (TELESCOPIC - 60/100)

2x FLUE CLAMPS

8x SCREWS

2x SEALS

The vertical flue kit is supplied with a specially designed weather proof terminal fitted, it can be used either with a flat roof or a pitched roof. (see **Figs 6.12, 6.13**).

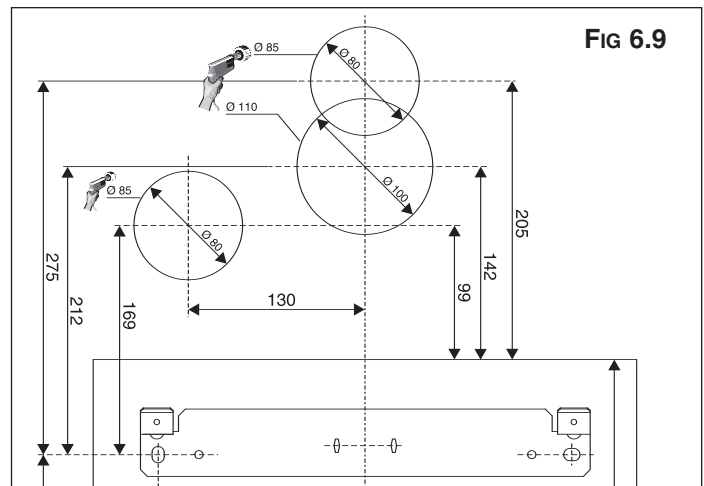

FIG 6.9

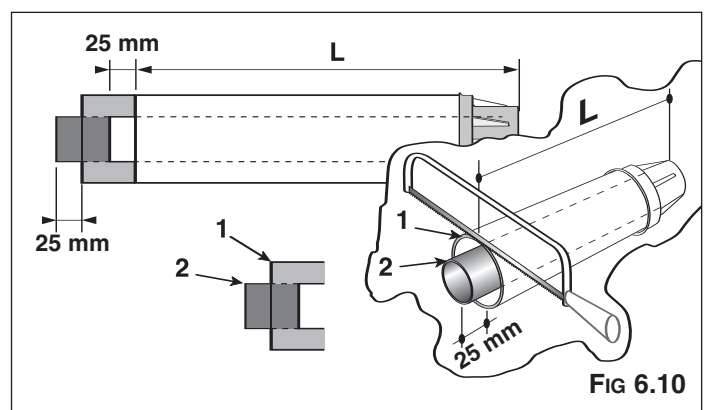

FIG 6.10

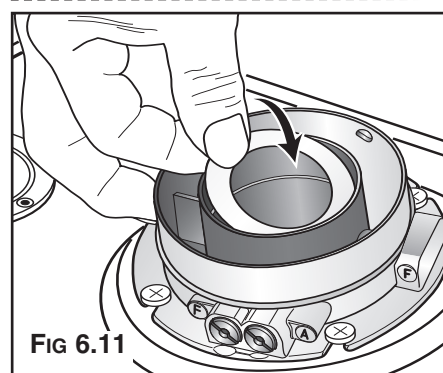

FIG 6.11

### IMPORTANT!

**For all flue systems, a restrictor may need to be inserted into the exhaust manifold, the size of the restrictor and details of fitting requirements are shown in Table 6.1 (Pages 18).**

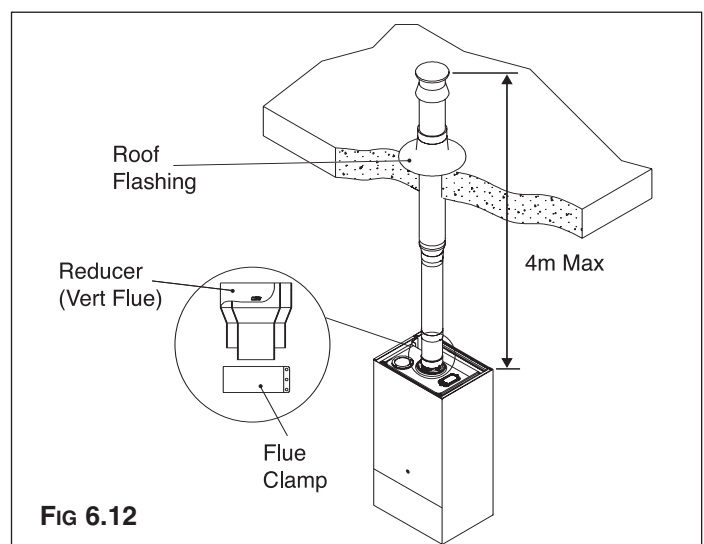

FIG 6.12

# Installation

The Vertical flue kits maximum and minimum useable lengths with both flat and pitched roof flashings are indicated in (Figs. 6.14 & 6.15).

Before proceeding to fit the flue, ensure that the maximum flue length has not been exceeded and that all elbows and bends have been taken into consideration, the maximum flue length is 4 metres, for each additional 90° elbow 1 metre must be subtracted from the total flue length, and for each 45° 0.5 metres must be subtracted from the total flue length (the offset and height of 2 x 45° can be seen in Fig. 6.16).

Mark the position of the flue hole in the ceiling and/or roof (see Fig. 6.14 for distance from wall to the centre of the flue).

Cut a 110mm diameter hole through the ceiling and/or roof and fit the flashing plate to the roof.

Should it be necessary to cut the flue **DO NOT** cut the outer white air inlet tube, cut the aluminium exhaust flue 6mm longer than the outer white air tube when used at minimum length. **DO NOT** cut more than 250mm from the inner aluminium exhaust flue.

To connect the vertical flue kit directly to the boiler, place the adaptor (see Fig 6.12) (supplied with vertical flue kit) onto the exhaust manifold and secure with the clamp, the vertical flue kit must then be inserted through the roof flashing, this will ensure that the correct clearance above the roof is provided as the terminal is a fixed height.

Should extensions be required, they are available in 1 metre (Part No. 705786), 500mm (Part No. 705790) and 160mm lengths (Part No. 705812), they must be connected directly to the boiler and secured with the clamp supplied before connecting the adaptor to allow the vertical flue kit to be fitted. In the event that extension pieces need to be shortened, they **must** only be cut at the male end and it must be ensured that the distance between the inner and outer flue are kept (Fig. 6.10).

When utilising the vertical flue system, action must be taken to ensure that the flue is supported adequately to prevent the weight being transferred to the appliance flue connection.

When the flue passes through a ceiling or wooden floor, there must be an air gap of 25mm between any part of the flue system and any combustible material. The use of a ceiling plate will facilitate this. Also when the flue passes from one room to another a fire stop must be fitted to prevent the passage of smoke or fire, irrespective of the structural material through which the flue passes.

## Fitting the Flue (Twin Pipe)

Where it is not possible to terminate the flue within the distance permitted for coaxial flues, the twin flue pipe can be used by fitting a special adaptor to the flue connector and using the aperture for the air intake located on top of the combustion chamber.

Considerations necessary for twin flue installation;

It is most important to avoid any possible condense formation entering the appliance.

According to Table 6.1 (Page 18) decide if condensation will form within the flue. If yes, there are two options;

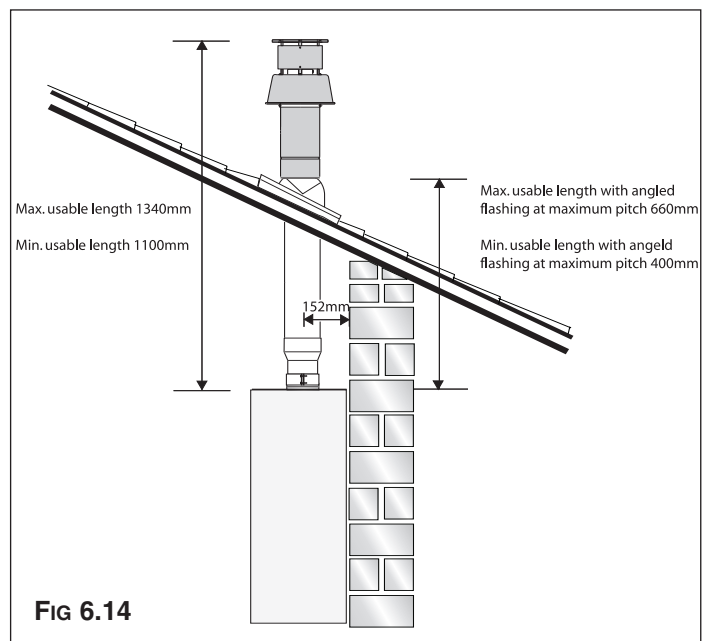
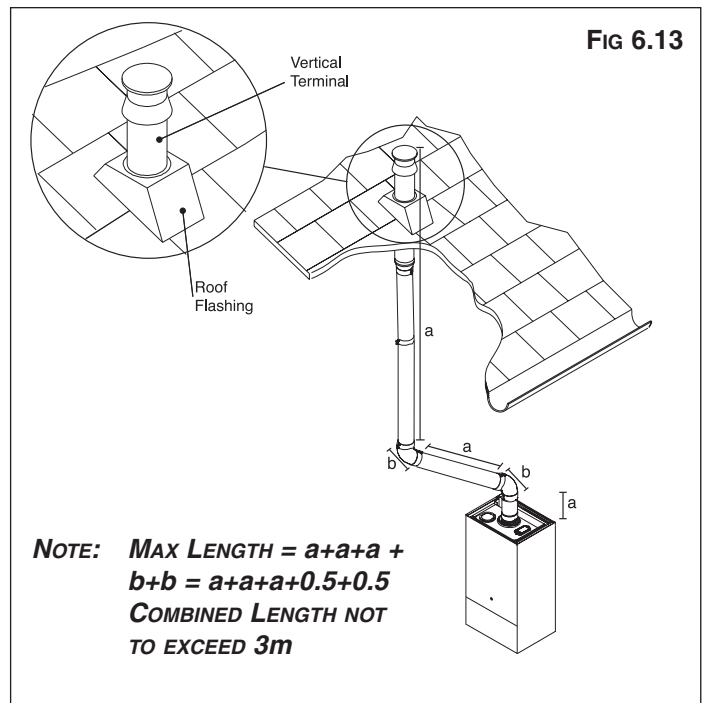

# Installation

- 1) Where condense will form but can be negated with insulated flue, install the insulated flue with a fall of 5mm in every metre away from the boiler.
- 2) The exhaust flue will have a fall of 3° back to the boiler and a suitable trap will be fitted on the exhaust as close to the boiler as possible, condense will then be suitably disposed of.

Where the flue runs through cold spots, i.e. loft areas, condense is likely to be formed, therefore a fall back to the boiler and a trap is required.

Always ensure that the flue is adequately supported, avoiding low points. (MTS supply suitable clamps as Part No. 705778).

To utilise the air intake it is necessary to:

Remove the 'knockout' of the air intake by cutting it with a suitable knife (**FIG. 6.16**).

Insert the elbow/flue pipe into the air intake until it stops.

The twin flue pipes can be fitted with or without additional elbows and need no clamps, simply ensure that the red o-ring is inserted in the female end of the flue pipe and push the extension piece fully into the previous section of flue pipe or elbow, check that the o-ring is not dislodged when assembling the flue.

Twin pipe can also be converted back to Coaxial flue to enable vertical termination with a coaxial kit by using the pipe bridge (Twin - Coaxial Adaptor - Part No. 705767). When running the twin flue pipe vertically, a condense trap must always be used on the exhaust pipe.

It is not recommended that the pipe bridge be used for horizontal termination, however in the unlikely event that this proves to be a necessity it is extremely important that the entire flue has a fall of 3° back to the boiler, is suitably trapped and where the 60mm inner flue of the concentric terminal connects to the pipe bridge, this point must be adequately sealed with silicone sealant to avoid condense leakage at this point.

**Note:** Vertical twin flue installations must have a trap on the exhaust. MTS supply a suitable condense trap with float Part No. 705774 and recommend that this be used in the event that the flue may not form condense.

When siting the twin flue pipe horizontally, the air intake and exhaust terminals **must** be a minimum of 280 mm apart and a maximum of 500mm, the air intake **must** not be sited above the exhaust terminal (**refer to FIG. 6.19**). The air intake pipe can be run horizontally, however, the terminal and the final 1 metre of flue must be installed with a fall away from the boiler to avoid rain ingress.

It is also strongly recommended that the air intake pipe run be constructed of insulated pipe to prevent condense forming on the outside of the tube.

The maximum permissible flue length for twin flue is dependent on the type of run used.

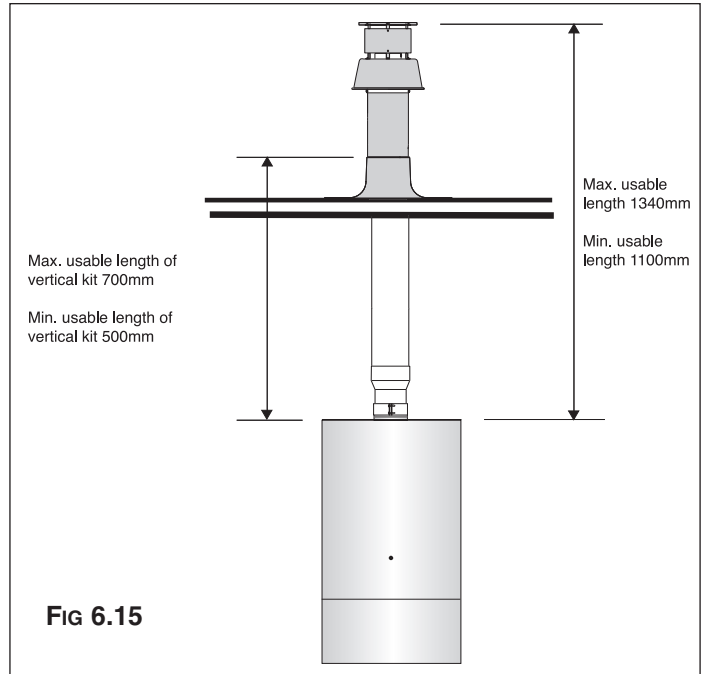

**FIG 6.15**

**IMPORTANT!**

**FOR ALL FLUE SYSTEMS, A RESTRICTOR MAY NEED TO BE INSERTED INTO THE EXHAUST MANIFOLD, THE SIZE OF THE RESTRICTOR AND DETAILS OF FITTING REQUIREMENTS ARE SHOWN IN TABLE 6.1 (PAGES 18).**

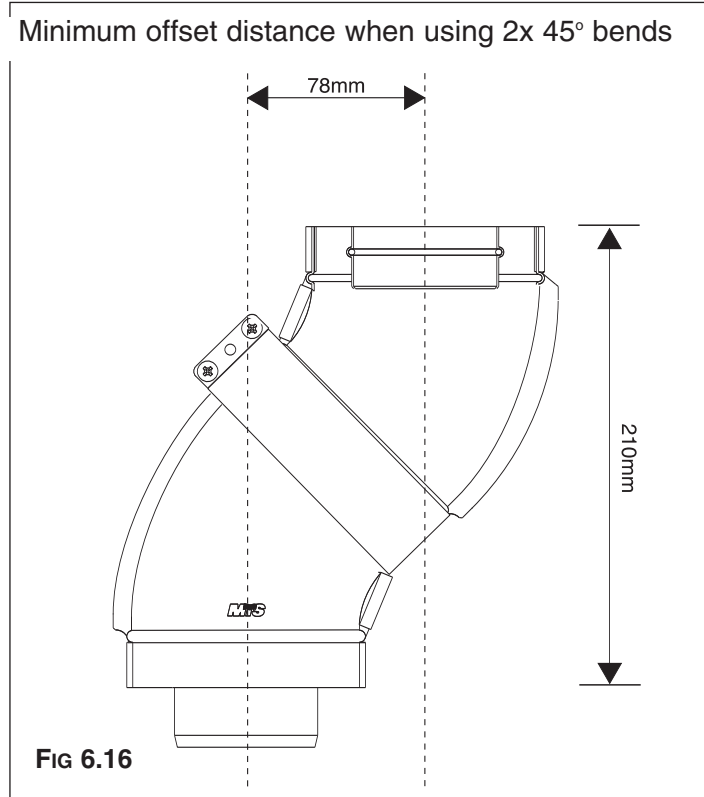

**FIG 6.16**

# Installation

For flue runs with the intake and exhaust pipes under the same atmospheric conditions (Type 4) the maximum length is 43 metres (80) and 28 metres (100), for runs with the terminals under different atmospheric conditions (Type 5) the exhaust terminal **must** extend 0.5 metres above the ridge of the roof (this is not obligatory if the exhaust and air intake pipes are located on the same side of the building). For Type 5 also, the maximum permissible combined length is 40 metres (80) and 51 metres (100).

The maximum length is reached by combining the total lengths of both the air intake and exhaust pipes. Therefore a maximum length of 40 metres for example, will allow a flue run of 20 metres for the air intake and 20 metres for the exhaust pipes, also for each 90° elbow 1.3 metres must be subtracted from the total length and for each 45° elbow 1 metre must be subtracted from the total flue length.

Some of the acceptable flue configurations are detailed on below (Fig. 6.19).

For further information relating to flue runs not illustrated, please contact the Technical Department on 01494 539579.

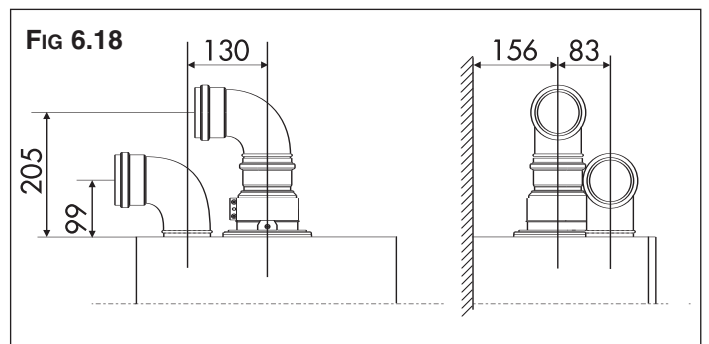
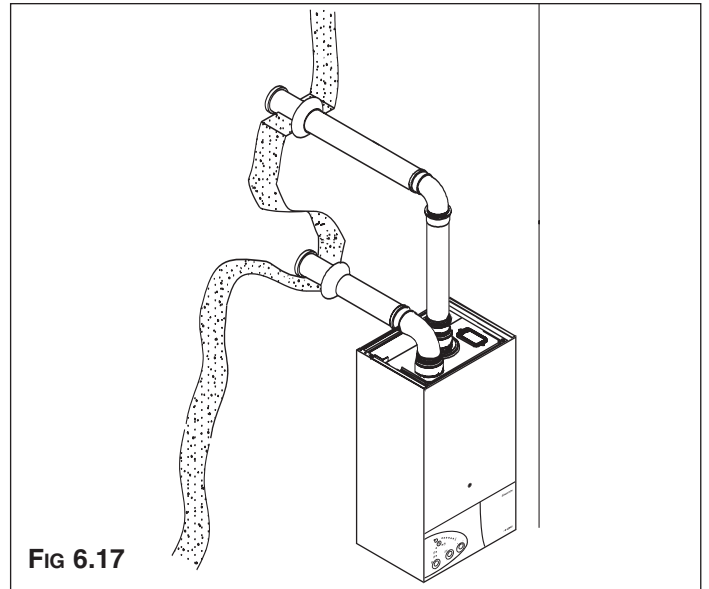
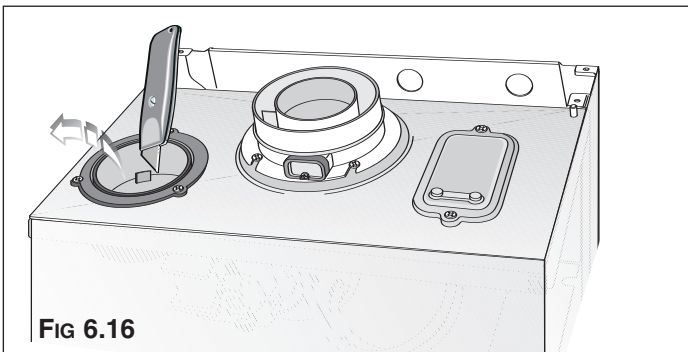



# Installation

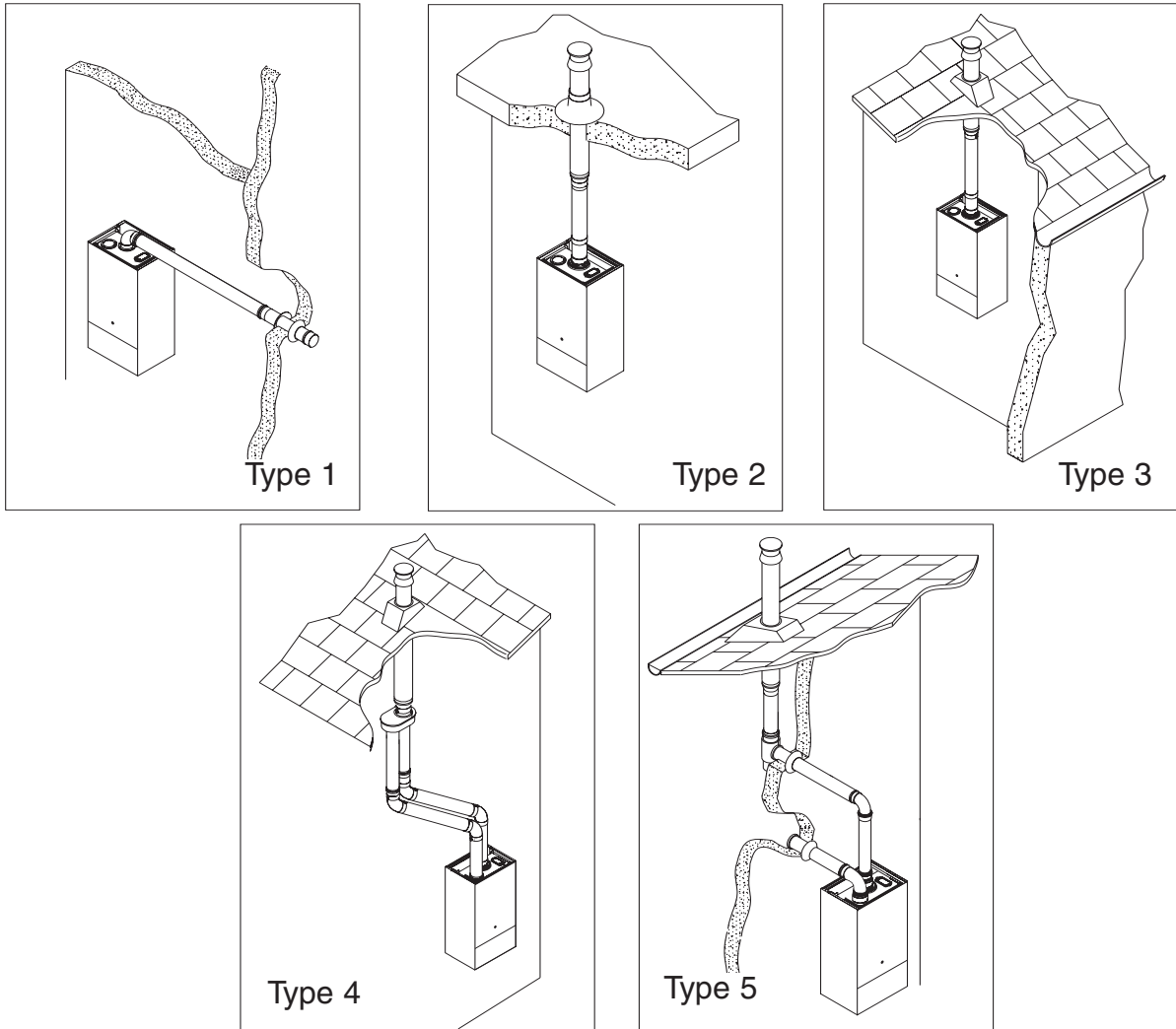

FIG. 6.19

**Note: Drawings are indicative of flueing options only.**

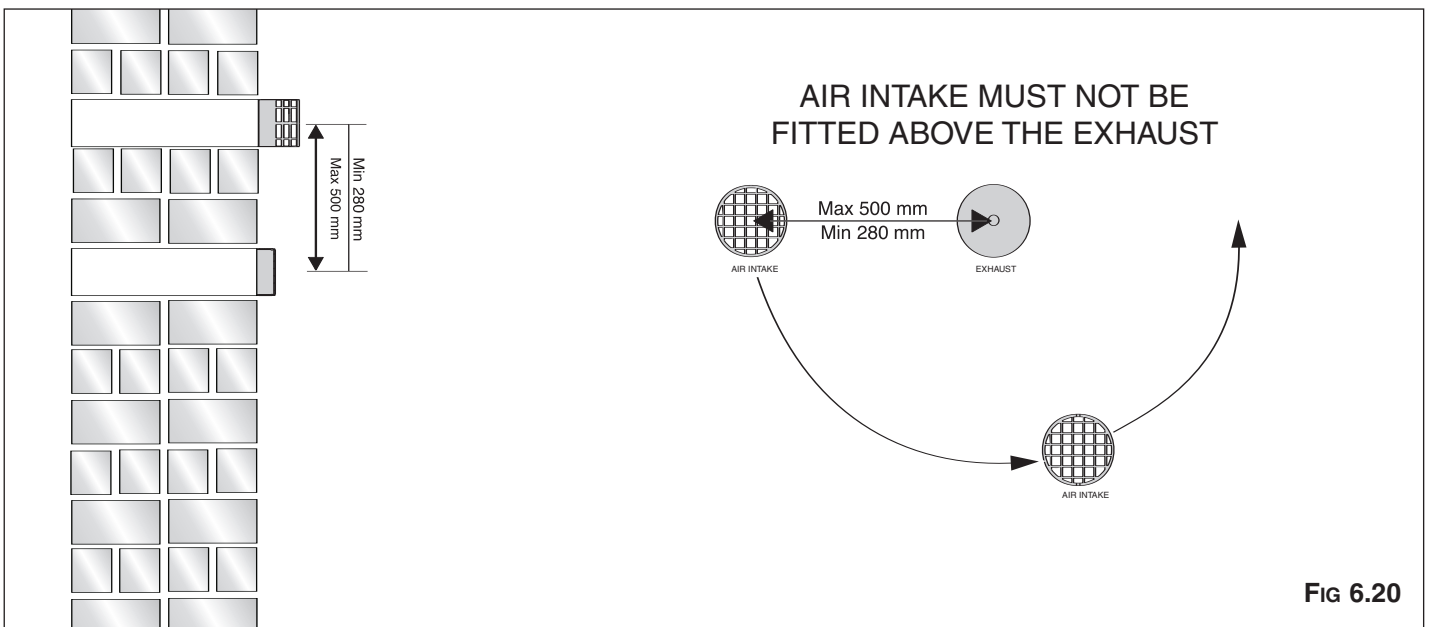

FIG 6.20

# Installation

## Excalibur 80

Table 6.1

	Exhaust Type	Use the ø 43 mm Restrictor	Do not use the Restrictor	Maximum Flue Length	Risk of Condensation Forming			
					Standard Twin Pipe After:		Insulated Twin Pipe After:	
Coaxial Systems ø 60/100	TYPE 1	Between 345 mm - 2 m	Between 2 m - 4 m	4 m	NOT APPLICABLE		NOT APPLICABLE	
	TYPE 2							
	TYPE 3							
Twin Pipe Systems ø 80/80	TYPE 4	Up to 11.5 m	Between 11.5 m - 43 m	43 m	4.3 m with a ø 43 mm restrictor	6.9 m without a ø 43 mm restrictor	N/A*	N/A*
	TYPE 5						Up to 11.4 m	Between 11.4 m - 40 m

## Excalibur 100

	Exhaust Type	Use the ø 45 mm Restrictor	Do not use the Restrictor	Maximum Flue Length	Risk of Condensation Forming			
					Standard Twin Pipe After:		Insulated Twin Pipe After:	
Coaxial Systems ø 60/100	TYPE 1	Between 345 mm - 1 m	Between 1 m - 4 m	4 m	NOT APPLICABLE		NOT APPLICABLE	
	TYPE 2							
	TYPE 3							
Twin Pipe Systems ø 80/80	TYPE 4	Up to 14 m	Between 14 m - 28 m	28 m	7 m with a ø 45 mm restrictor	7 m without a ø 45 mm restrictor	10 m* with a ø 45 mm restrictor	24 m* without a ø 45 mm restrictor
	TYPE 5						Up to 21 m	Between 21 m - 51 m

\* Where there is no risk of condense forming (and, therefore no requirement for a condense collector), ensure a minimum fall of 5mm per metre away from the appliance.

\*\* Maximum Length = combined length of air intake and exhaust pipes (less any equivalent lengths for elbows).

**Note:** Under some circumstances, condense may form at the exhaust terminal, special attention must be paid with regard to possible condense dripping from the terminal.

# Installation

## 6.10 Control Panel

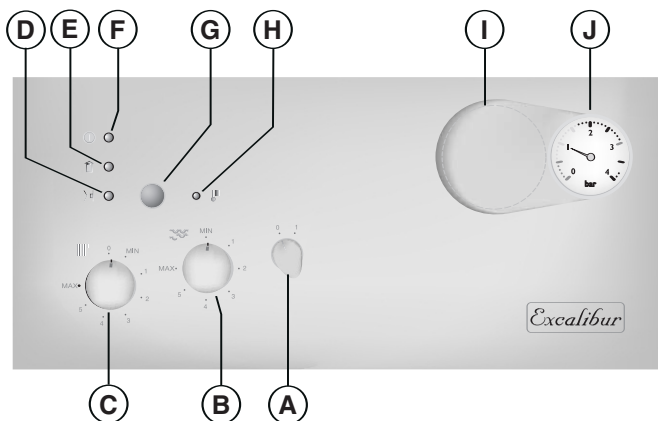

- A - On/Off knob
- B - Domestic Hot Water temperature adjustment knob
- C - Central Heating selection (winter) and temperature adjustment knob
- D - Ignition failure (lockout) L.E.D. (red)
- E - Fume sensor L.E.D. (yellow)
- F - On/Off L.E.D. (green)
- G - Ignition failure (lockout) and/or overheat reset button /*Flue Analysis Modes\**
- H - Overheat L.E.D. (red)
- I - Time clock
- J - Central Heating system pressure gauge

\* **Warning!** the flue analysis mode must only be selected by a qualified service engineer.

## 6.11 Removing the Front Panel

In order to access the inside of the boiler, it is necessary to unscrew the fastening screws "A" of the control panel located on the lower part of the panel itself.

The control panel moves downward and when pulled forward rotates on two lateral hinges.

The panel stays in a semi-horizontal position, which allows access to the inner parts of the boiler.

In order to increase the manoeuvring space, it is possible to raise the control panel and rotate it to a fully horizontal position.

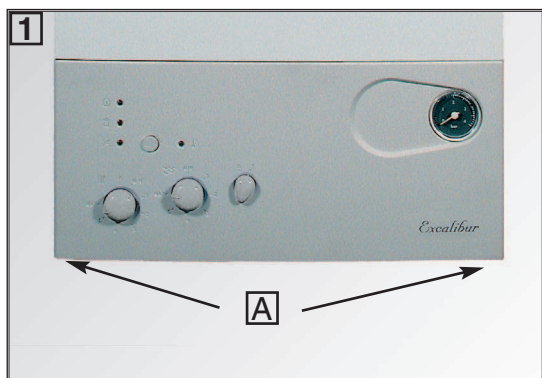

- 1 - Remove the two screws "B";
- 2 - Move the front casing panel up and lift forward.

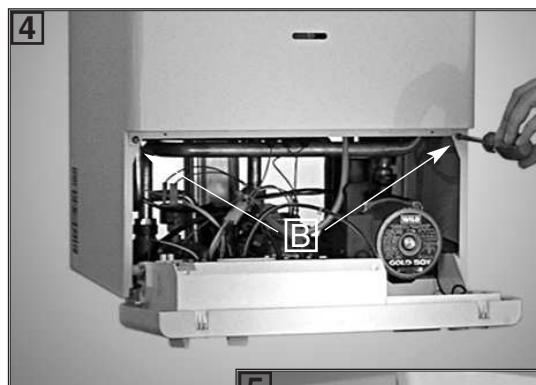

# Installation

## 6.12 Fitting the Time Clock

To fit the mechanical time clock supplied with the boiler, it is necessary to proceed as follows:

- 1) Remove the fastening screws 'A' from beneath the boiler;
- 2) Rotate the control panel forward, if necessary, it is possible to lift the control panel up and rotate it to a fully horizontal position;
- 3) Using a suitable knife, remove the knock out 'B' for the time clock;
- 4) Insert the clock into the control panel;
- 5) Secure the clock in place using the four screw provided;
- 6) Remove the two screws 'C' and remove the cover to allow access to the Printed Circuit Board;
- 7) Plug the clock cable into the connector on the Printed Circuit Board and connect the cables to the clock as indicated in Fig. 6.21

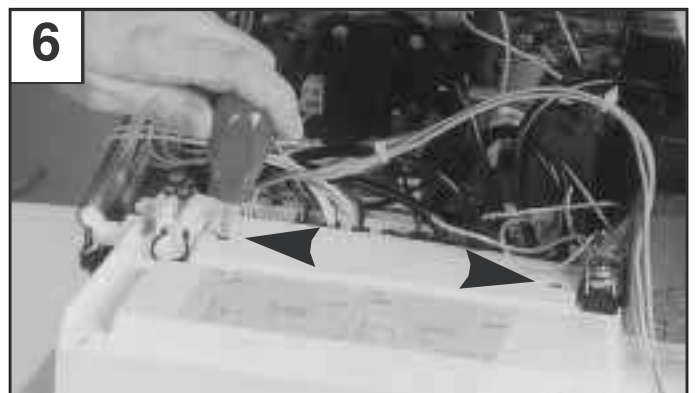
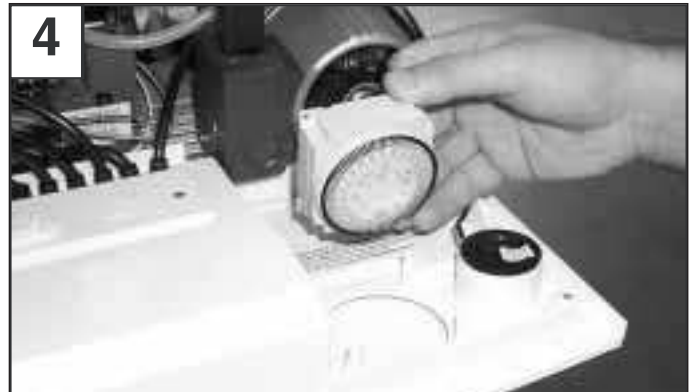
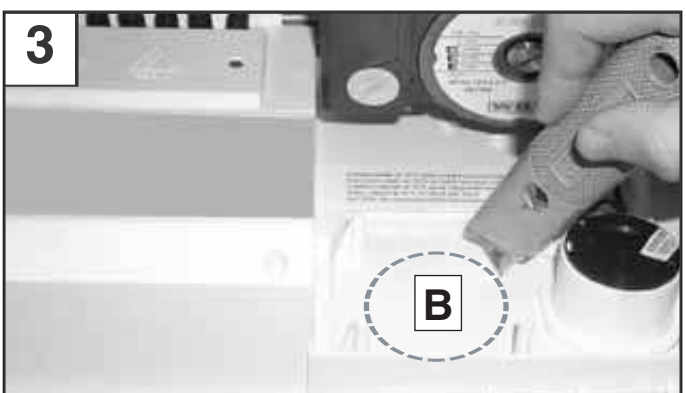
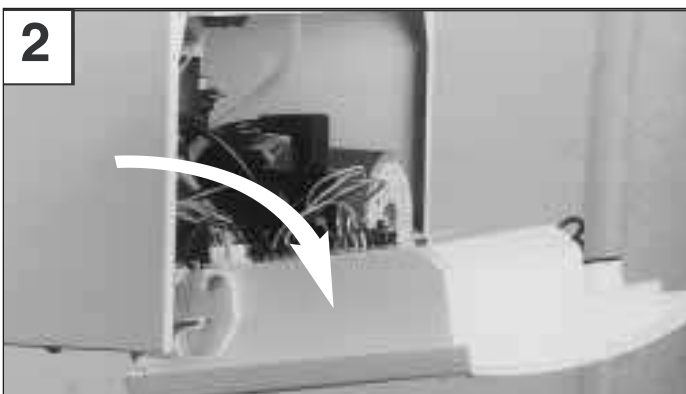
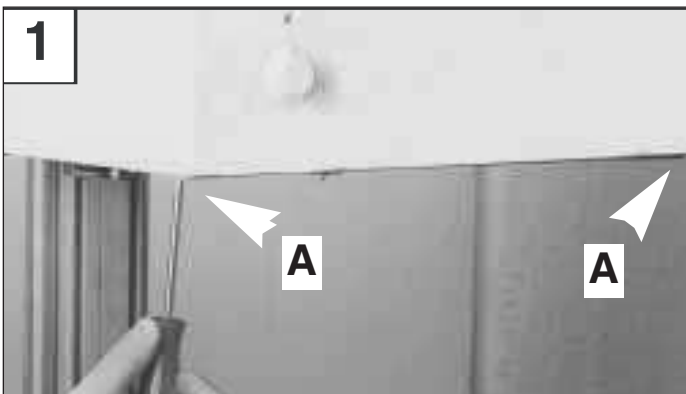

---

# Installation

---

## 6.12 Fitting the Time Clock (continued)

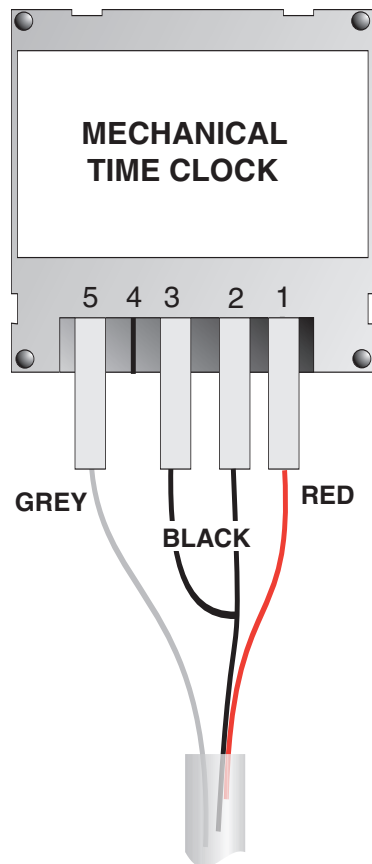
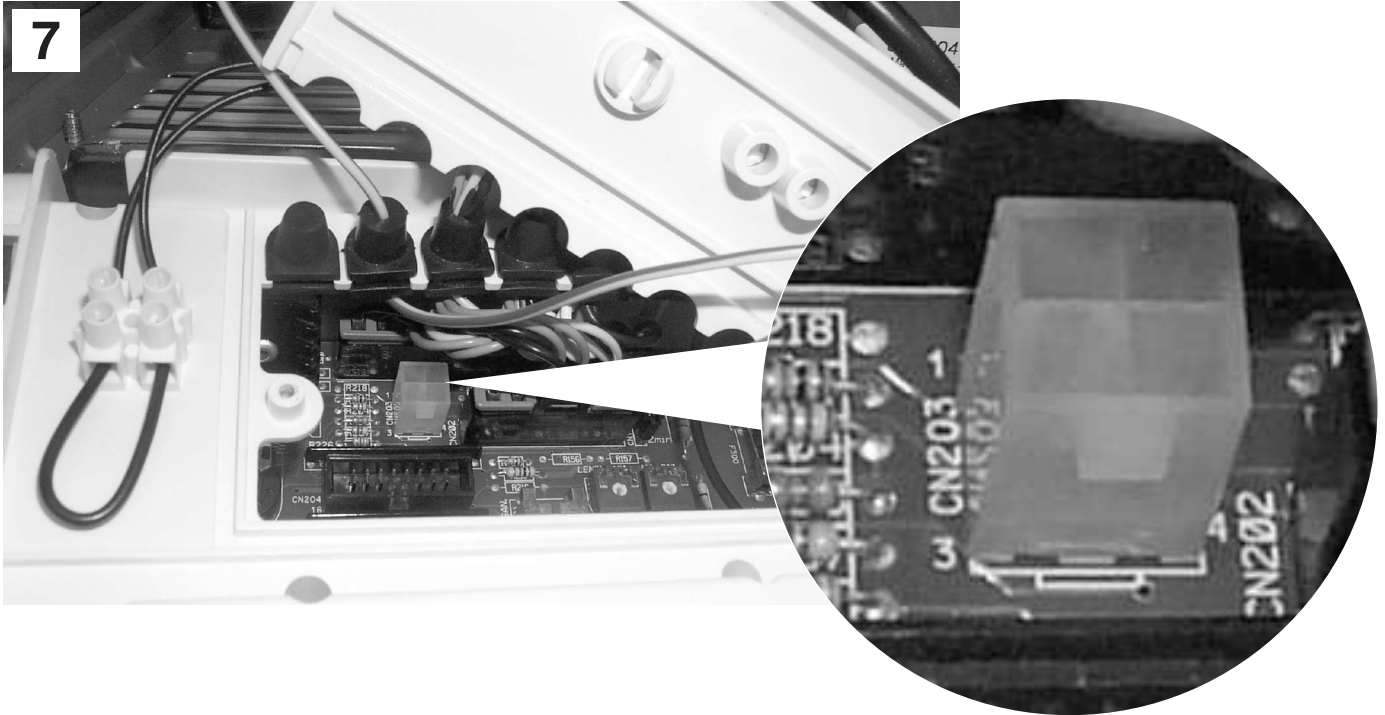

FIG. 6.21

# Installation

## 6.13 Room Thermostat Connection

To connect a room thermostat, it is necessary to:

- 1 - Open the control panel as indicated in SECTION 6.11.
- 2 - Remove the link "A" from the terminal block on the reverse of the control panel.
- 3 - Insert the thermostat cable through the cable grommet and fasten it by means of the cable-clamp provided.
- 4 - Connect the thermostat wires to the terminal block (Diagram A).
- 5 - If a remote time clock is to be fitted, disconnect the integral time clock from the P.C.B.
- 6 - Using a volt-free switching time clock, connect the switching wires from the time clock following points 1-4 above (Diagram B).
- 7 - If using an external time clock and room thermostat, these must be connected in series as points 1-7 above (Diagram C).

**Note: Only a low voltage room thermostat capable of volt free switching must be used. Factory fitted integral wiring must not be disturbed when wiring external controls.**

**Important!!**

**DO NOT** install 240v wires and low voltage switching wires in the same cable/conduit, this may cause unwanted induced voltages in the low voltage switching system.

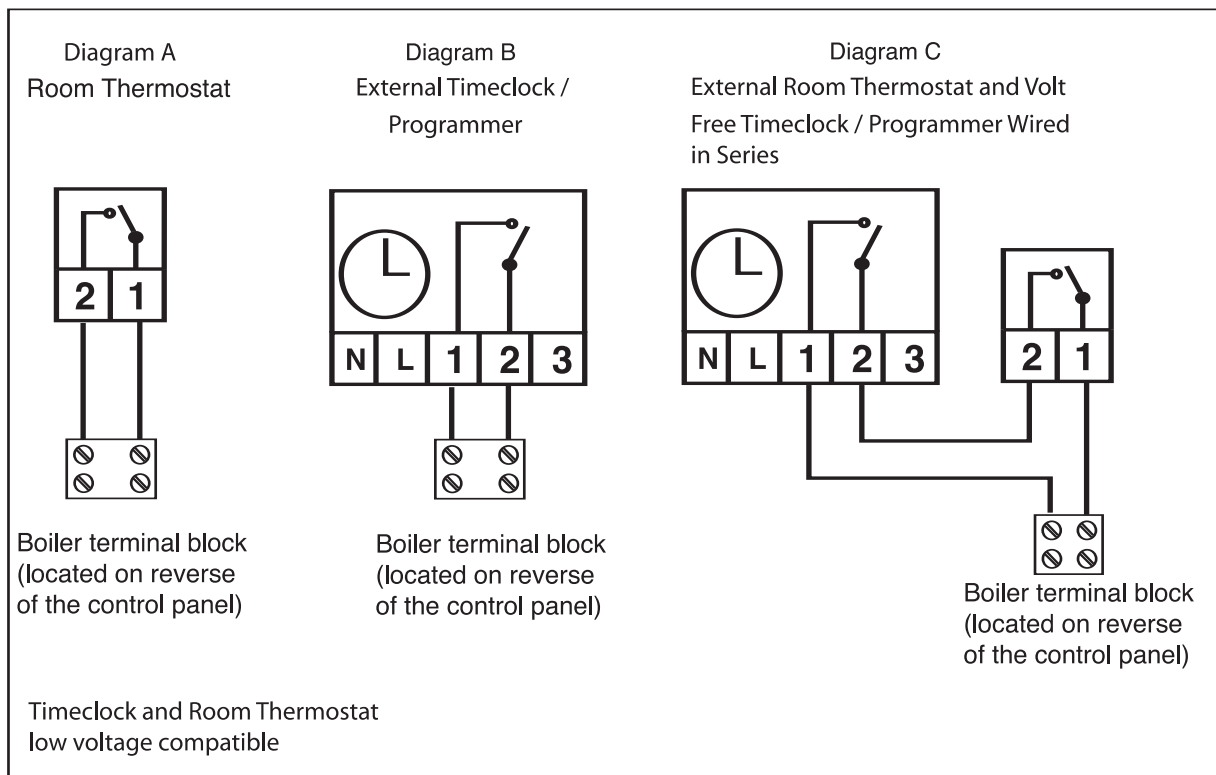
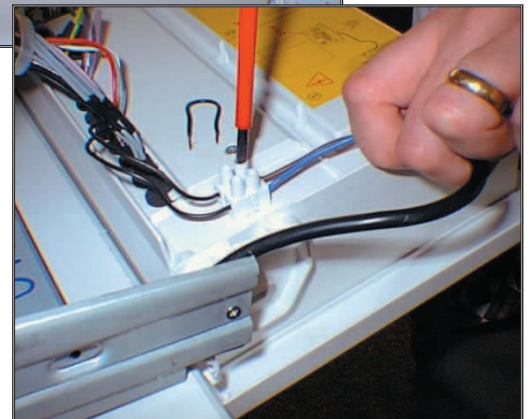
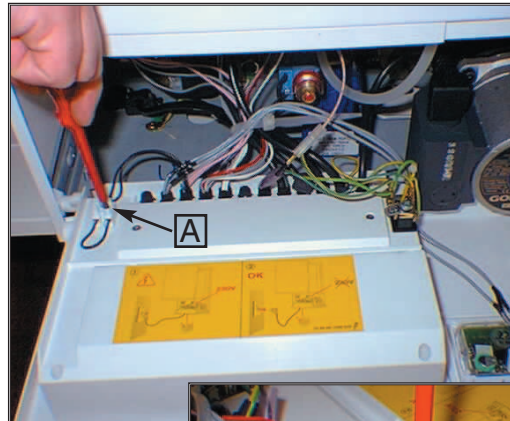
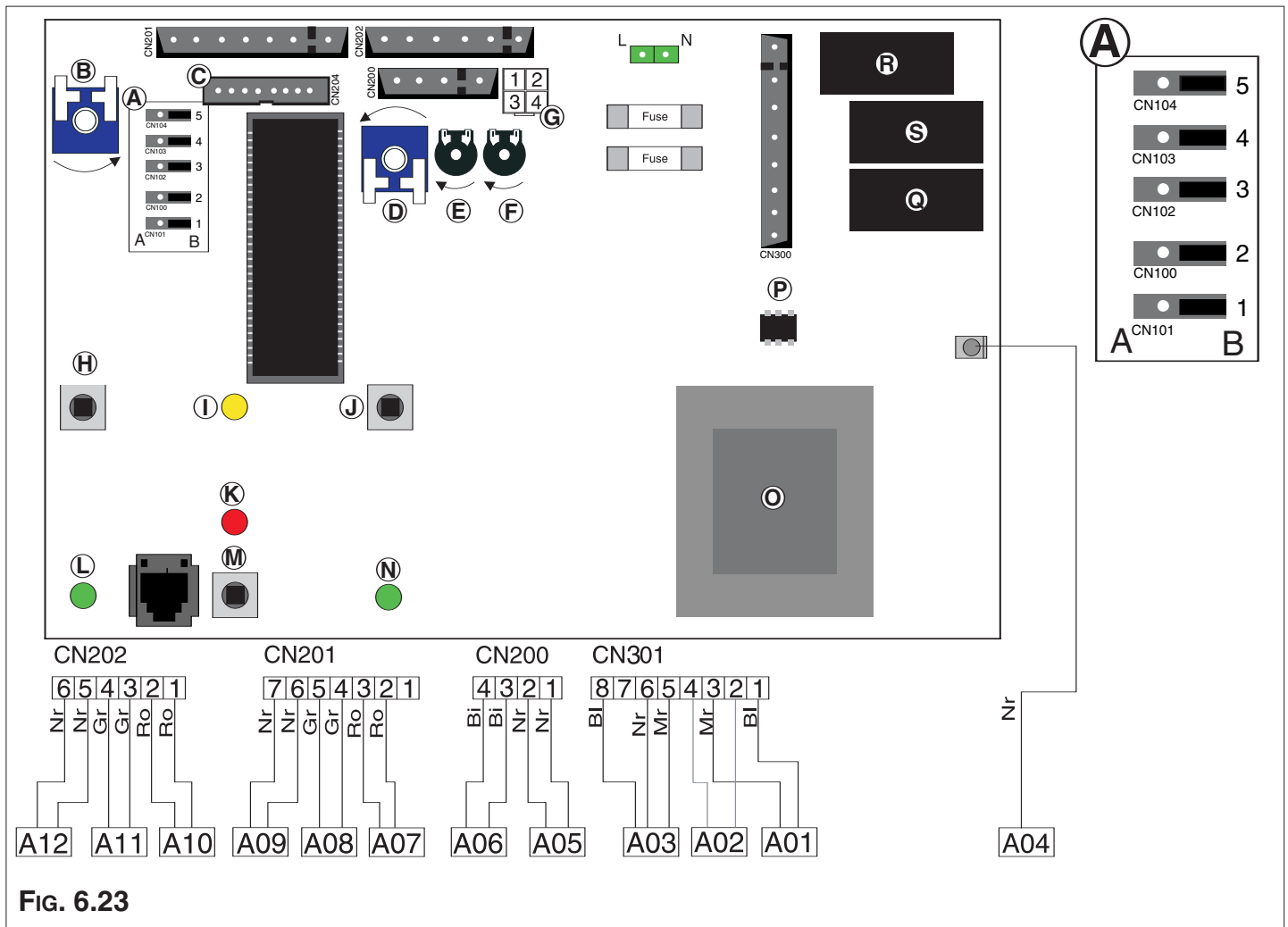

FIG. 6.22

# Installation

## 6.14 ELECTRICAL/SYSTEM DIAGRAMS



**FIG. 6.23**

**A - Jumper:**

- 1 - Don't move (jumper is factory set in position B)
- 2 - Anti-cycling Device Adjustment for Heating  
Position A = 0 mins      Position B = 2 mins
- 3 - Don't move (jumper is factory set in position B)
- 4 - Don't move (jumper is factory set in position B)
- 5 - Fan/Pump over-run selector  
Position A = OFF      Position B = ON

- B - Central Heating Temperature Adjustment
- C - Connector for Remote Control (Climate Manager)
- D - Domestic Hot Water Temperature Adjustment
- E - Soft-light Adjustment
- F - Maximum Heating Adjustment
- G - Time Clock Connector
- H - On/Off Switch
- I - Fume Sensor L.E.D.
- J - Central Heating Selector
- K - Ignition Failure (Lockout) L.E.D.
- L - On/Off L.E.D.
- M - Reset Button
- N - Central Heating L.E.D.
- O - Transformer

**P - Spark Generator I.C.**

- Q - Gas Valve Relay
- R - Circulation Pump Relay
- S - Fan Relay

- A01 - Circulation Pump
- A02 - Fan
- A03 - Spark Generator/Gas Valve Supply
- A04 - Detection Electrode
- A05 - Main Circuit Temperature Probe
- A06 - Domestic Hot Water Temperature Probe
- A07 - D.H.W. Flow switch
- A08 - Pump Pressure Switch
- A09 - Modulator
- A10 - Air Pressure Switch
- A11 - Safety Thermostat
- A12 - External (Room) Thermostat

**COLOURS:**

- Gr - Grey
- Bi - White
- Rs - Red
- Mr - Brown
- Bl - Blue
- Nr - Black
- Ro - Pink

# Installation

## 6.15 Water Circuit Diagram

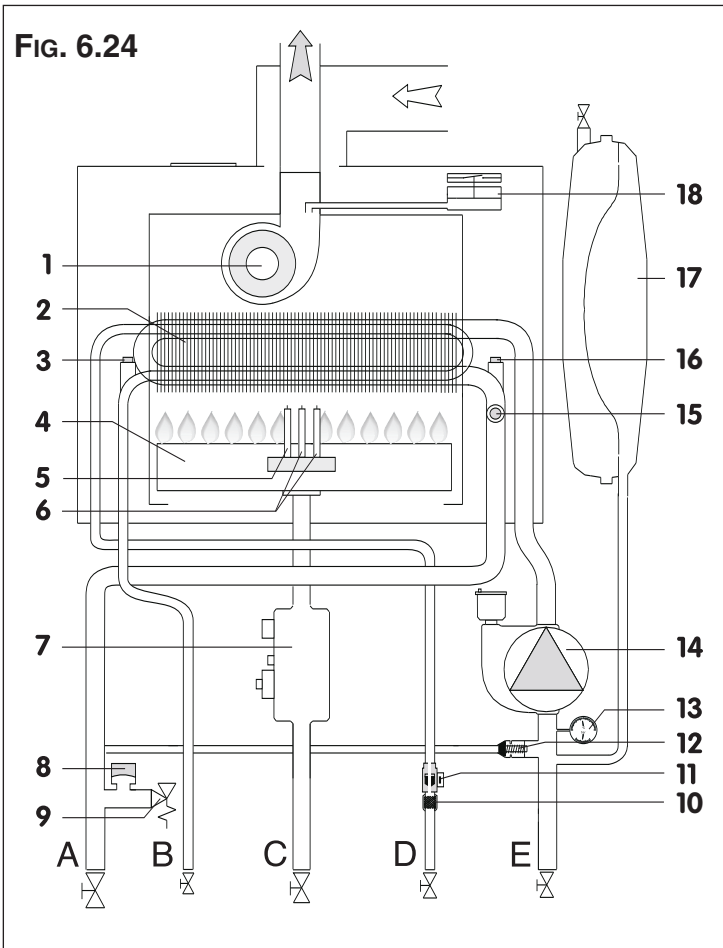

### Legend:

1. Fan
  2. "Twin-pass" Heat Exchanger
  3. Domestic Hot Water Temperature Probe
  4. Burner
  5. Detection Electrode
  6. Ignition Electrodes
  7. Gas Valve
  8. Low Water Pressure Switch
  9. Safety Valve
  10. D.H.W. inlet filter
  11. D.H.W. Flow Switch
  12. Automatic By-pass
  13. Pressure Gauge
  14. Circulation Pump with Automatic Air Release Valve
  15. Overheat Thermostat
  16. Main Circuit Temperature Probe
  17. Expansion Vessel
  18. Air Pressure Switch
- 
- A. Central Heating Flow
  - B. Domestic Hot Water Outlet
  - C. Gas Inlet
  - D. Domestic Cold Water Inlet
  - E. Central Heating Return



---

---

## 7. COMMISSIONING

---

---

### 7.1 Initial Preparation

Preliminary electrical system checks to ensure electrical safety must be carried out by a competent person i.e. polarity, earth continuity, resistance to earth and short circuit.

#### *FILLING THE HEATING SYSTEM:*

Lower the control panel and remove the case panels (see **SECTION 6.11** for further information).

Open the central heating flow and return cocks supplied with the connection kit (there are two isolation points on the return connection).

Unscrew the cap on the automatic air release valve one full turn and leave open permanently.

Close all air release valves on the central heating system.

Gradually open valve(s) at the filling point (filling-loop) connection to the central heating system until water is heard to flow, do not open fully.

Open each air release tap starting with the lowest point and close them only when clear water, free of air, is visible.

**Purge the air from the pump by unscrewing the pump plug anticlockwise, also manually rotate the pump shaft in the direction indicated by the pump label to ensure the pump is free.**

Refit the pump plug.

Continue filling the system until at least 1.5 bar registers on the pressure gauge.

Inspect the system for water soundness and remedy any leaks discovered.

#### *Filling of the D.H.W. System:*

Close all hot water draw-off taps.

Open the cold water inlet cock supplied with the connection kit. Open slowly each draw-off tap and close them only when clear water, free of bubbles, is visible.

#### *Gas Supply:*

Inspect the entire installation including the gas meter, test for tightness and purge the supply as described in BS 6891:1988. Open the gas cock (supplied with the connection kit) to the appliance and check the gas connections on the appliance for leaks.

When the installation and filling are completed, flush the system while cold, refill, turn on the Central Heating system (**Section 7.2**) and run it until the temperature has reached the boiler operating temperature. The system must then be immediately flushed through.

The flushing procedure must be in line with BS 7593:1992 code of practice for treatment of water in domestic hot water central heating systems.

During this operation, we highly recommend the use of a central heating flushing detergent (Ferox Superfloc or equivalent), whose function is to dissolve any foreign matter that may be in the system.

**Substances different from these could create serious problems to the pump or other components.**

The use of an inhibitor in the system such as Ferox MB-1 or equivalent is strongly recommended to prevent corrosion (*sludge*) damaging the boiler and system.

**Failure to carry out this procedure may invalidate the appliance warranty.**

### 7.2 Initial Start-up

#### *THE CHECKS TO BE RUN BEFORE INITIAL START-UP ARE AS FOLLOWS:*

1. Make sure that:
  - the screw on the automatic air valve has been loosened when the system is full;
  - If the water pressure in the system is below 1 bar, bring it up to the appropriate level;
  - Ensure that the gas cock is closed;
  - Make sure that the electrical connection has been made properly and that the earth wire is connected to an efficient earthing system;
  - Supply power to the boiler by pushing the On/Off button "A" the L.E.D. "K" will illuminate. Then push the button "F" in for central heating - the L.E.D. "G" will illuminate. This will start the circulation pump. After 7 seconds, the boiler will signal a shutdown due to ignition failure. Leave the boiler as it is until all of the air has been bled from the system.
  - Loosen the cap on the head of the pump to eliminate any air pockets;
  - Repeat the procedure for bleeding the radiators of air;
  - Open the taps for a brief period;
  - Check the system pressure and, if it has dropped, open the filling loop again to bring the pressure back up to 1 bar.
2. Make sure that all gate valves are open;
3. Turn on the gas cock and check the seals on the connections with an approved soap solution and eliminate any leaks.
4. Press the reset button "J" for the lighting system; the spark will light the main burner. If the burner does not light the first time, wait 1 minute and repeat the procedure.
5. Check the minimum and maximum burner pressure values; adjust if needed using the values indicated in the table in **SECTION 8**.

### 7.3 Operational Adjustments

To access the areas in which adjustments are made, it is necessary to open the control panel, as indicated in **Section 6.11**, then remove the rear inspection cover by unscrewing the two screws. Access is thereby provided to the P.C.B. and to the following components:

1. The power supply cable connector;
2. The fuses;
3. The soft-light potentiometer the setting for which can range from the minimum thermal power to the maximum;
4. The maximum thermal heating power potentiometer adjustable by the minimum to maximum power (already calibrated in the factory to 70% of the maximum thermal power);
5. The jumper for adjusting the ignition delay (anti-cycling) feature, which can be set from 0 to 2 minutes (set in the factory at two minutes);
6. Fan/Pump Over-run (Electrical Diagram). When the jumper is set to position A the Fan and Pump over-run is activated. (The jumper is factory set in position B)
7. The time clock connector.

# Commissioning

## 7.4 Combustion Analysis

The flue connector has two apertures, readings can be taken for the temperature of the combustion by-products and of the combustion air, as well as of the concentrations of O<sub>2</sub> and CO<sub>2</sub>, etc.

To access these intakes it is necessary to unscrew the front screw and remove the metal plate with sealing gasket.

It is possible to activate the flue test mode (maximum output) by pressing and holding the RESET button "G" for 10 seconds, the yellow L.E.D. "E" will light. The boiler will return to normal operation after 5 minutes. The boiler can be returned to normal operation sooner by switching the boiler off and on again.

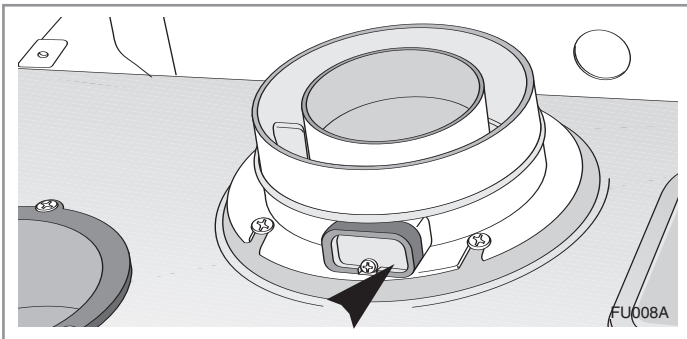

## 7.5 Product of Combustion Discharge Monitoring

In the boiler, it is possible to monitor the correct operation of the flue exhaust/air intake, checking for a loss of general pressure in the system. Through the use of a differential manometer connected to the test points of the combustion chamber, it is possible to detect the P of operation of the air pressure switch.

The value detected should not be less than 0.55 mbar (80) - 0.90 mbar (100) under conditions of maximum thermal power in order for the boiler to function properly and without interruption.

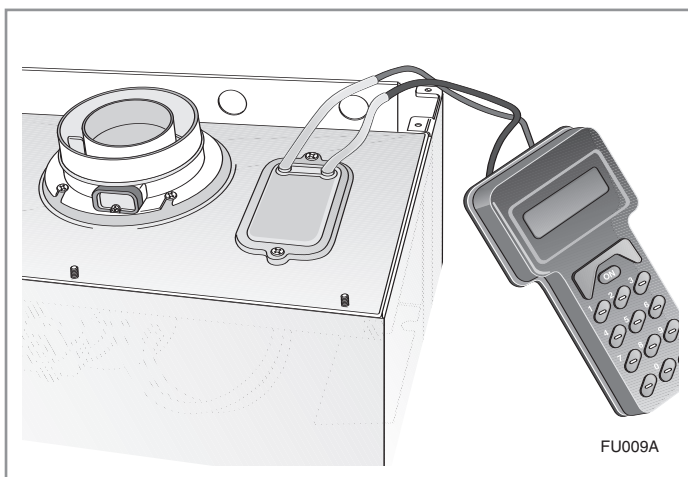

## 7.6 Boiler Safety Systems

The boiler is fitted with the following devices (see SECTION 6.10 for references).

### 1 - Ignition Failure:

This indicates ignition failure when a flame is not detected within 7 seconds of starting an ignition sequence. The L.E.D. "D" will illuminate to signal the shutdown status.

The system can be reset by pressing and releasing the button "G" after checking to make sure that the gas cock is open.

### 2 - Insufficient System Pressure:

In the event of insufficient water pressure in the heating system, a safety device will shutdown the boiler. Check the system pressure on the pressure gauge "J" and if it is less than 0.4 bar refill the system to 1.5 bar. Once the system pressure is at the correct level the boiler will reset automatically.

### 3 - Overheating:

This control shuts off the boiler in the case where the primary circuit reaches a temperature in excess of 105°C.

The red L.E.D. "H" will illuminate to signal this shutdown status.

The system can be reset by waiting a few minutes for the primary exchanger to cool down and then by pressing and releasing the "G" button.

### 4. Anti-frost device:

The boiler is fitted with a device which, in the event that the water temperature falls below 8°C the pump activates and runs until a temperature of 18°C is attained. In the event that the water temperature falls below 3°C, the diverter valve switches to Domestic Hot Water and the burner fires and runs on minimum power until a temperature of 33°C is attained.

This device is only activated when the boiler is operating perfectly and

- the system pressure is sufficient;
- the boiler is powered electrically;
- gas is being distributed.

### 6. Exhaust Discharge Anomaly Shutdown:

The boiler is fitted with safety devices, which in the event of defective discharge of exhaust products, automatically interrupts the gas supply, thereby shutting off the boiler.

The shutdown of the boiler is temporary and is indicated by the illumination of the yellow L.E.D. "E" for a period of about 15 minutes.

Once this time period has passed and the discharge state of exhaust fumes has returned to normal, the boiler automatically turns back on.

### 7. Pump Protection:

To prevent the pump from seizing the boiler will activate the pump for 20 seconds every 21 hours after it's last operation.

---

---

# Commissioning

---

---

## 7.7 Draining the System

### **Draining the Heating System**

The heating system must be drained as follows:

- Turn off the boiler;
- Attach a hose pipe and open the drain valve;
- Drain the system at the lowest points (where present). When the heating system is unused for an extended period of time, it is recommended that you add antifreeze with an ethylene glycol base to the water in the heating pipe work and radiators if the ambient temperature drops below 0°C during the winter.

This makes repeated draining of the entire system unnecessary.

### **Draining the Domestic Hot Water System**

Whenever there is the danger of the temperature dropping below the freezing point, the domestic hot water system must be drained as follows:

- Turn off the general water valve for the household plumbing system;
- Turn on all the hot and cold water taps;
- Empty the remaining water from the lowest points in the system (where present).

## 7.8 Completion

For the Republic of Ireland it is necessary to complete a "Declaration of Conformity" to indicate compliance to I.S. 813. An example of this is given in the current edition of I.S. 813. In addition it is necessary to complete the *(benchmark)* Log Book.

## 7.9 Operational Checks

1. The flue system must be visibly checked for soundness.
2. Run the Central Heating and manipulate the Central Heating temperature control knob to check the gas pressures at high and low fire with a pressure gauge/manometer, and adjust if necessary.
3. Range rate the thermal power for Central Heating, as detailed in **SECTION 8.2**
4. Run the Domestic Hot Water, manipulate the Domestic Hot Water temperature control knob to check the gas pressures at high and low fire with a pressure gauge/ manometer, and adjust if necessary.
5. Balance the Central Heating system until all return temperatures are correct and equal.
6. Turn ON/OFF button OFF, disconnect the pressure Gauge, retighten screw and re-light boiler.
7. Re-examine Central Heating, Domestic Hot Water and Cold Water supplies for soundness.
8. Check the appearance of the gas flame to assess the adequacy of the combustion air supply.
9. If external controls have been disconnected, reconnect and test.
10. Refit boiler casing.

## 7.10 Instructing The End User

1. Hand over the copy of the End User Instructions supplied with the appliance, together with these instructions, and explain how to use the timeclock and room thermostat if fitted.
2. Show the End User how to switch the appliance off quickly, and indicate the position of the electric supply isolator.
3. Inform the End User of the location of all drains, isolating valves and air vents.
4. Explain how to turn the appliance off for both short and long periods and advise on the precautions necessary to prevent damage in the event that the appliance is inoperative when freezing conditions occur.
5. Finally advise the End User that, for continued safe and efficient operation, the appliance must be serviced by a competent person at least once a year.

## 8. GAS ADJUSTMENTS

Model	CATEGORY I12H3+		Methane Gas G20	Liquid Butane Gas G30	Liquid Propane Gas G31
80 100	Lower Wobbe Index (15°C;1013mbar)	MJ/m <sup>3</sup> h	45.67	80.58	80.58
	Nominal Delivery Pressure	mbar	20	29	37
	Minimum Delivery Pressure	mbar	20	28	36
80	Main Burner: n. 12 jets (ø)	mm	1.30	0.77	0.77
	Consumption (15°C; 1013mbar)	m <sup>3</sup> /h	2.78	----	----
	Consumption (15°C; 1013mbar)	Kg/h	----	2.02	2.00
	Gas Burner Pressure max - min	mbar	11.0 - 2.0	27.7 - 6.0	35.5 - 7.3
100	Main Burner: n. 13 jets (ø)	mm	1.3	0.77	0.77
	Consumption (15°C; 1013mbar)	m <sup>3</sup> /h	3.10 - 1.16	---	---
	Consumption (15°C; 1013mbar)	Kg/h	---	2.31 - 0.87	2.27 - 0.85
	Gas Burner Pressure max - min	mbar	12.2 - 1.7	27.8 - 5	35.8 - 5.3

### 8.1 Changing the Type of Gas

The boiler can be converted to use either methane (natural) gas (G20) or L.P.G. (G30 - G31) by an Authorised Service Centre.

The operations that must be performed are the following:

1. Replace the jets on the main burner (see table in section 8);
2. Adjust the maximum and minimum thermal capacity values for the boiler (see table in section 8 and 8.2 Adjusting the Gas Pressures);
3. Adjust the maximum thermal power setting;
4. Adjust the soft-light feature (see table below for recommended pressure);
5. Adjust the ignition delay feature for the heating system by adjusting the jumper 2 as shown in Section. 6.13 (can be set from 0 to 2 mins.).

CATEGORY I12H3+	Model Microcombi	Methane Gas G20	Liquid Butane Gas G30	Liquid Propane Gas G31
Recommended Soft-light Pressure (mbar)	80	8.0	16.0	16.0
	100	6.7	12	12

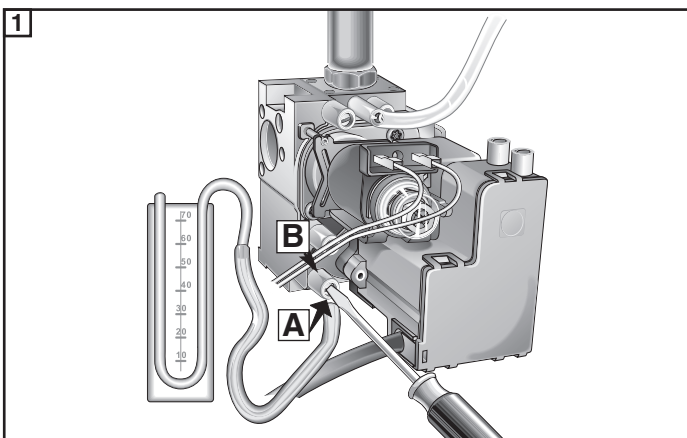

### 8.2 Adjusting the Gas Pressures

#### Setting the minimum and the maximum power of the boiler

1. Check that the supply pressure and dynamic pressure to the gas valve is a minimum of 20 mbar for natural gas.
2. To do this, loosen the screw "A".  
Fit the pipe of the pressure gauge to the inlet pressure connection of the gas valve "B" and check for the correct standing pressure, then operate the appliance and check for the correct working pressure.  
When you have completed this operation, replace the screw "A" securely into its housing to seal off the gas (check for tightness).
3. To check the pressure supplied by the gas valve to the burner, loosen the screw "C". Fit the pipe of the pressure gauge to the pressure outlet test point of the gas valve "D".  
Disconnect the compensation pipe "D1" either from the gas valve or from the sealed chamber.
4. Push the On/Off button to "ON" position -green light- and ensure that the hot water temperature control knob is set to maximum.  
Turn on the boiler by running a hot water tap.  
Adjust the 10mm nut "E" on the modereg to set the maximum gas pressure, turn the nut clockwise to increase and anti clockwise to decrease the pressure until the required pressure is achieved (see TABLE A page 28).

# Gas Adjustments

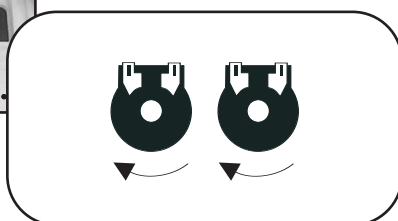
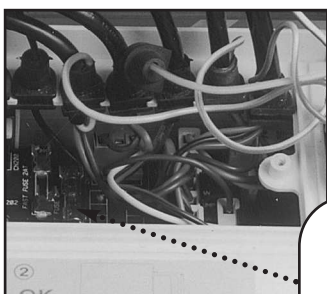
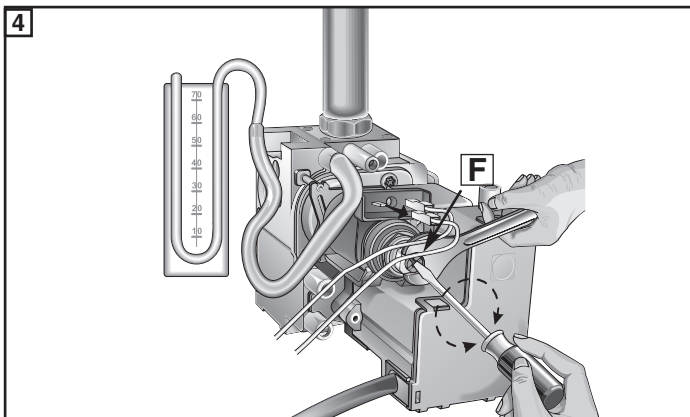
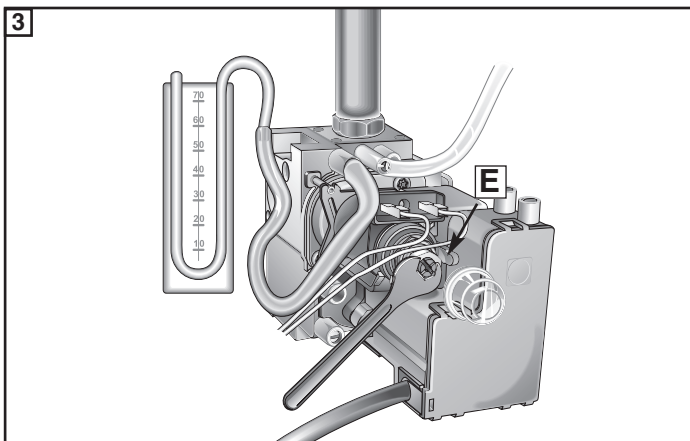
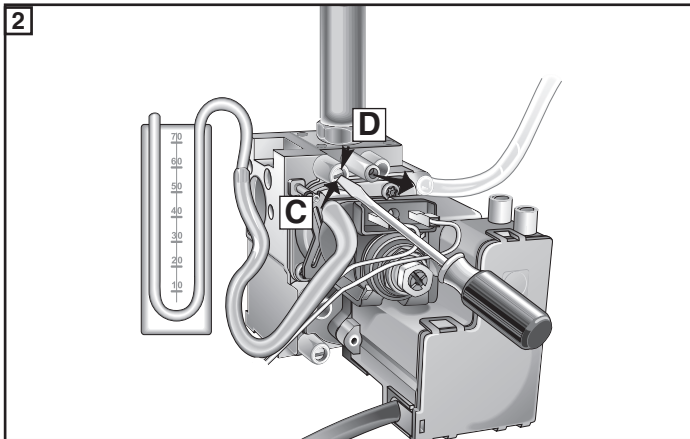

Soft - Light Adjustment    Max Heating Adjustment

5. To set the minimum power, disconnect a supply terminal "F1" from the modureg and adjust screw "F" (ensure that the 10mm nut is held in position). Turn the screw clockwise to increase the pressure and anti-clockwise to decrease the pressure (displayed on the pressure gauge) corresponding to the minimum power (see **TABLE A** page 28).
6. When you have completed the above operations, turn off the hot water tap, reconnect the supply terminal to the modureg on the gas valve, reconnect the compensation pipe and replace the cap on the screw of the modureg.

### Setting the maximum heating circuit power

7. To set the maximum heating circuit power, push the On/Off button to the "ON" position -*green light*- and push the Heating button and set the time clock and any external controls to the "ON" position -*green light*. Turn the knob of the heating thermostat clockwise to maximum.
8. Remove the inspection panel of the P.C.B. and fit a small cross-head screwdriver in to the right hand potentiometer (see below). Turn clockwise to increase the pressure or counter-clockwise to reduce the pressure. Adjust the setting to the required heating pressure value (displayed on the pressure gauge), as indicated in the charts shown on pages 28.
9. Turn off the boiler by placing the main switch to the "OFF" position.

### Setting the pressure for soft-light ignition.

Disconnect the detection electrode connection close to the P.C.B. (Fig. 6.13).

Start the boiler and during the ignition sequence adjust the left hand potentiometer until the gas pressure reads the required gas pressure (**see the table on page 28**).

Once the gas pressure is set turn off the boiler and re-connect the detection electrode to the P.C.B.

NB.: It may be necessary to reset the flame failure reset a number of times during this operation.

10. Remove the pipe from the test point and tighten the screw "C" to the pressure test point in order to seal off the gas.
11. Carefully check the pressure test points for gas leaks (valve inlet and outlet).

### IMPORTANT!

Whenever you disassemble and reassemble the gas connections, always check for leaks using a leak detection fluid.

# Gas Adjustments

TABLE A

<i>Excalibur 80</i>		GAS REQUIREMENTS		NATURAL GAS (G20)	BUTANE GAS (G30)	PROPANE GAS (G31)
		Gas rate	max	2.78 m <sup>3</sup> /h	2.02 Kg/h	2.00 Kg/h
		Gas rate	min	1.16 m <sup>3</sup> /h	0.87 Kg/h	0.85 Kg/h
		Inlet pressure		20 mbar	28 mbar	37 mbar
		Burner pressure	max	11.0 mbar	27.5 mbar	35.5 mbar
		Burner pressure	min	2.0 mbar	6.2 mbar	7.3 mbar
		Burner jets		12 x 1.30	12 x 0.77	12 x 0.77
<i>Excalibur 100</i>		GAS REQUIREMENTS		NATURAL GAS (G20)	BUTANE GAS (G30)	PROPANE GAS (G31)
		Gas rate	max	3.10 m <sup>3</sup> /h	2.31 Kg/h	2.27 Kg/h
		Gas rate	min	1.16 m <sup>3</sup> /h	0.87 Kg/h	0.85 Kg/h
		Inlet pressure		20 mbar	28 mbar	37 mbar
		Burner pressure	max	12.2 mbar	27.8 mbar	35.8 mbar
		Burner pressure	min	1.7 mbar	5 mbar	5.3 mbar
		Burner jets		13 x 1.30	13 x 0.77	13 x 0.77

Regulating the heating power for natural gas (G20)

Regulating the heating power for butane gas (G30)

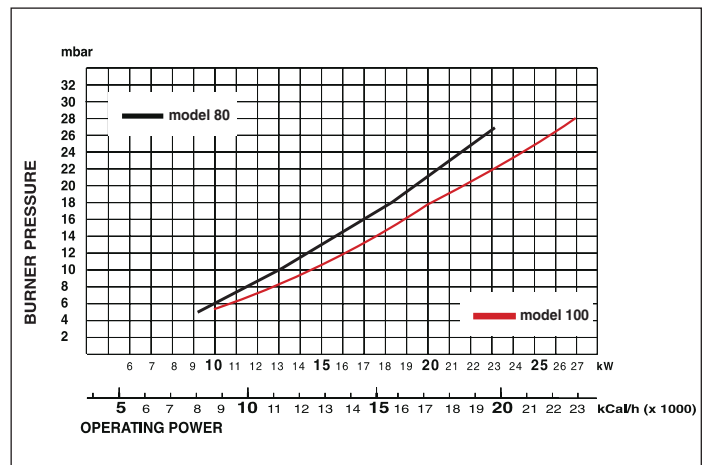
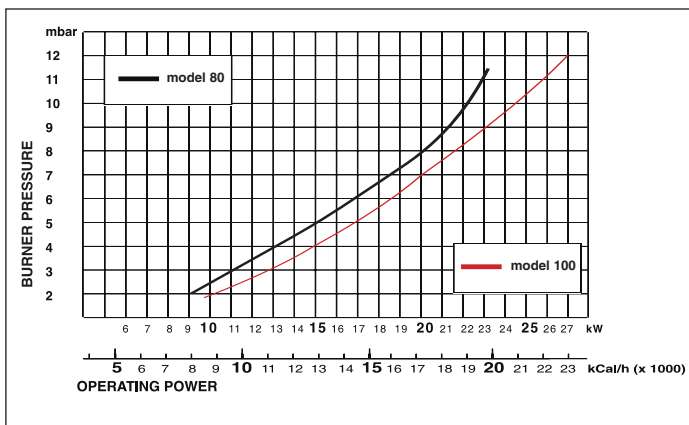

Regulating the heating power for propane gas (G31)

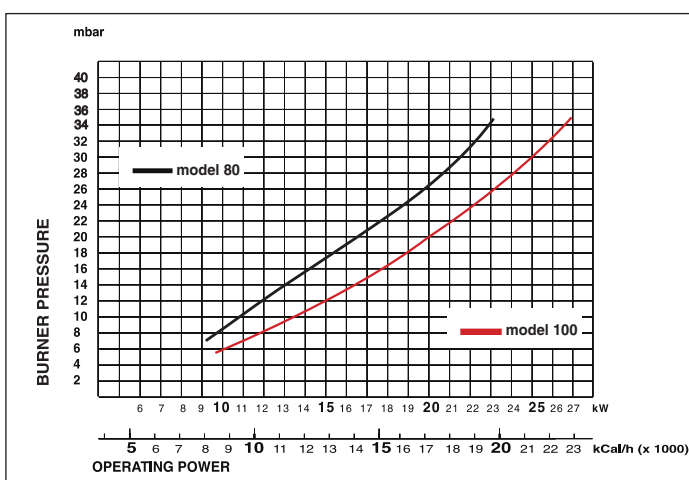

---

---

## 9. MAINTENANCE

---

---

***It is recommended that the following inspections be carried out on the boiler at least once a year:***

- 1 - Check the seals for the water connections; replace any faulty seals.
- 2 - Check the gas seals; replace any faulty gas seals.
- 3 - Visual check of the entire unit.
- 4 - Visual check of the combustion process or analysis of combustion by-products (see section 3.6) and cleaning of the burner if needed.
- 5 - If called for by point. 3, dismantling and cleaning of the combustion chamber.
- 6 - If called for by point. 4, dismantling and cleaning of the burner jets.
- 7 - Visual check of the primary heat exchanger:
  - check for overheating in the blade assembly;
  - clean the exhaust fan if needed.
- 8 - Adjustment of the flow rate of the gas: flow rate for lighting, partial load and full load.
- 9 - Check of the heating safety systems:
  - safety device for maximum temperature (overheat thermostat);
  - safety device for maximum pressure (safety valve).
- 10- Check of the gas safety systems:
  - safety device for lack of gas or flame ionisation (detection electrode);
  - safety device for gas cock.
- 11- Check of the electrical connection (make sure it complies with the instructions in the manual).
- 12- Check of domestic hot water production efficiency (flow rate and temperature)
- 13- General check of the combustion by-products of the discharge/ventilation system.
- 14- Check of the general performance of the unit.

# 10. SERVICING INSTRUCTIONS

To ensure efficient safe operation, it is recommended that the boiler is serviced annually by a competent person.

**Before starting any servicing work, ensure both the gas and electrical supplies to the boiler are isolated and the boiler is cool.**

Before and after servicing, a combustion analysis should be made via the flue sampling point (please refer to SECTION 3.4 for further details).

After servicing, preliminary electrical system checks must be carried out to ensure electrical safety (i.e. polarity, earth continuity, resistance to earth and short circuit).

## 10.1 Replacement of Parts

The life of individual components vary and they will need servicing or replacing as and when faults develop.

The fault finding sequence chart in SECTION 7 will help to locate which component is the cause of any malfunction, and instructions for removal, inspection and replacement of the individual parts are given in the following pages.

## 10.2 To Gain General Access

All testing and maintenance operations on the boiler require the control panel to be lowered. This will also require the removal of the casing.

### 10.2.1 Removing the front panel

1. Loosen the fastening screws "A" of the control panel located on the lower part of the panel itself. (Fig. 10.1);

FIG. 10.1

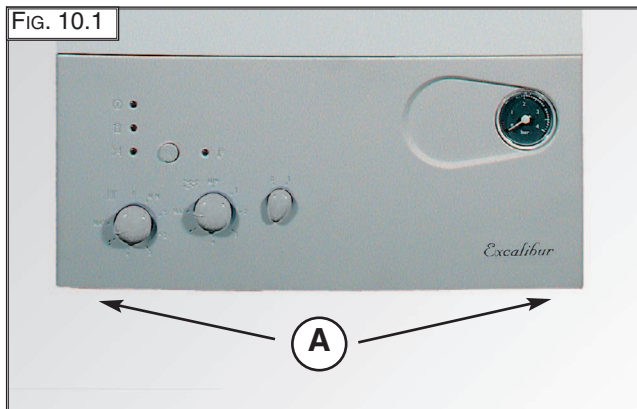

FIG. 10.2



FIG. 10.3



2. The control panel moves downward and when pulled forward, rotates on two lateral hinges; the panel stays in a semi-horizontal position, which allows access to the inner parts of the boiler (Fig. 10.2);
3. In order to increase the manoeuvring space, it is possible to raise the control panel and rotate it to a fully horizontal position (Fig. 10.3);
4. Remove the screws "B" from the front panel bottom lip (Fig. 10.4);
5. Lift the front panel up and forward from the raised screws at the top of the casing (Fig. 10.5).

FIG. 10.4

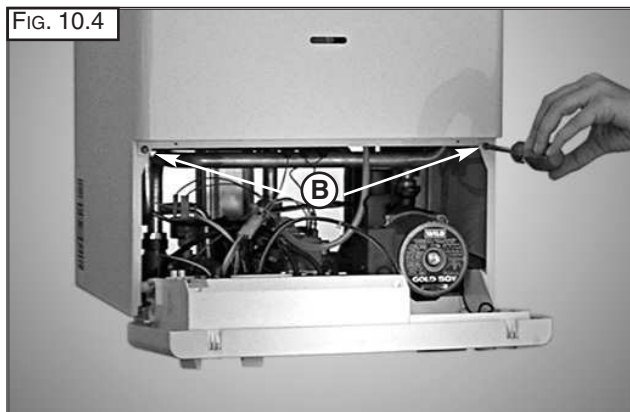

FIG. 10.5



# Servicing Instructions

## 10.2.2 Removing the sealed chamber front cover

1. Remove the screws "C" (FIG. 10.6);
2. Lift the sealed chamber front cover from the locating pins (FIG. 10.7).

FIG. 10.6

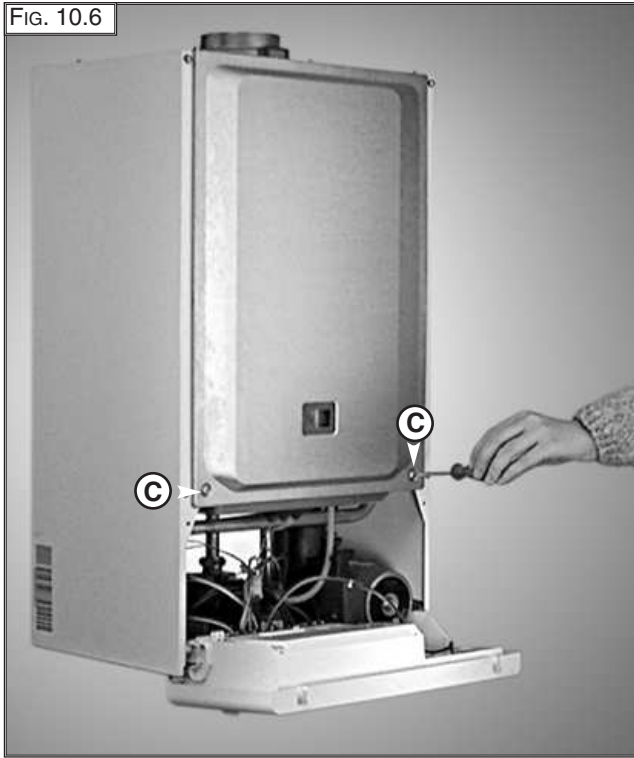
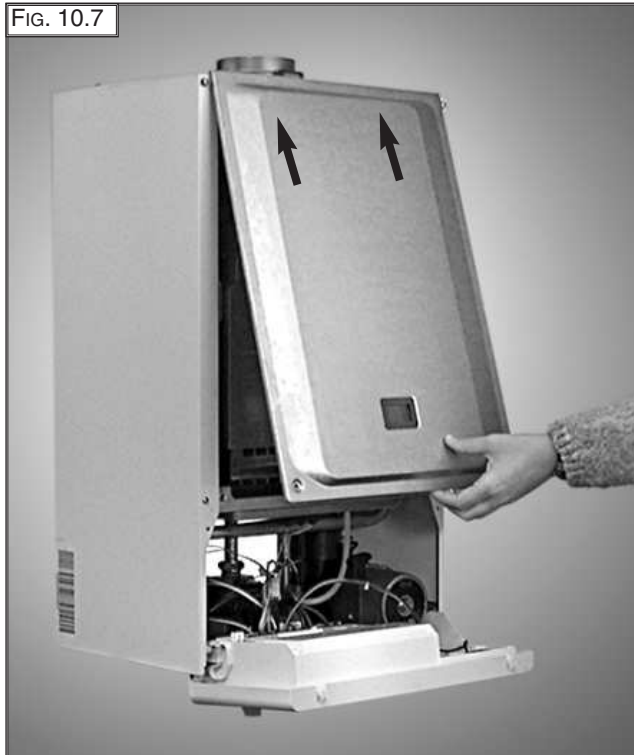

FIG. 10.7



## 10.2.3 Removing the side panels

1. Remove the four screws "D" for each side panel (FIG. 10.8);
2. Pull the panel away from the boiler at the base, then lift the panel up and remove from the boiler (FIG. 10.9).

FIG. 10.8

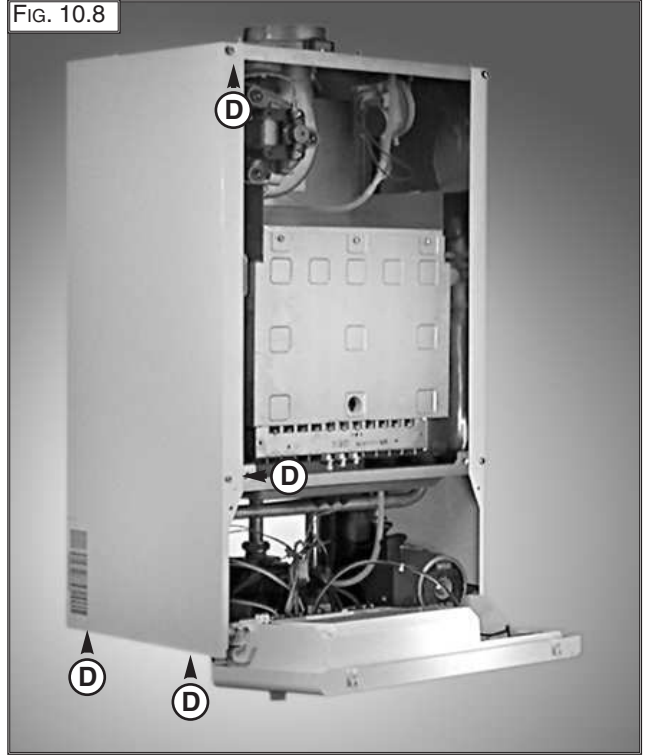
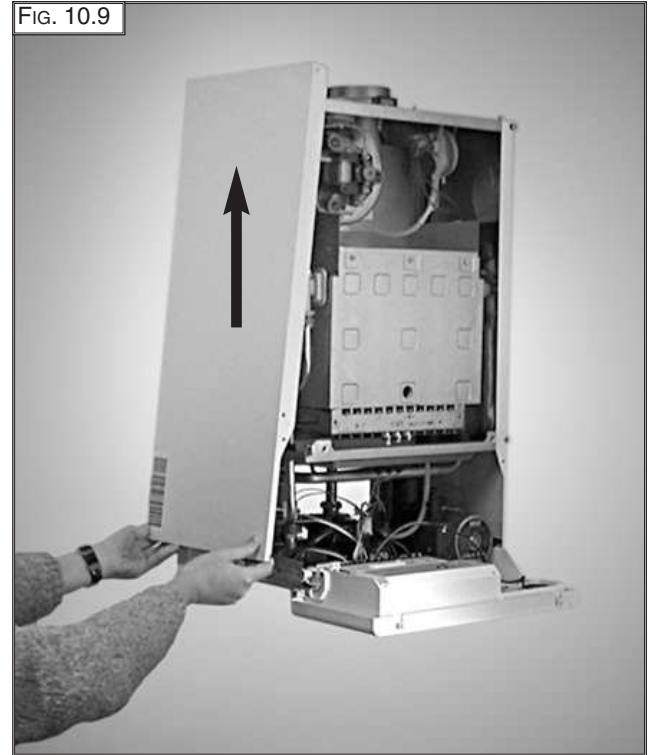

FIG. 10.9



# Servicing Instructions

## 10.3 Access to the Combustion Chamber

### 10.3.1 Removing the combustion cover

1. Remove the screws "E" (Fig. 10.10);
2. Lift off the combustion cover.

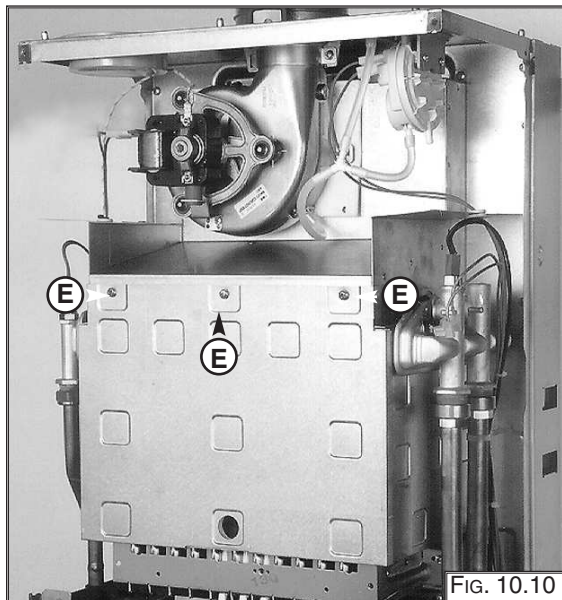

### 10.3.2 Removing the burner and jets

1. Remove the screws "F" from the burner (Fig. 10.11);
2. Remove the burner (Fig. 10.12);
3. Disconnect the electrodes (see SECTION 10.3.3);
4. Remove the jets using a No. 7 socket spanner;
5. Replace in reverse order.

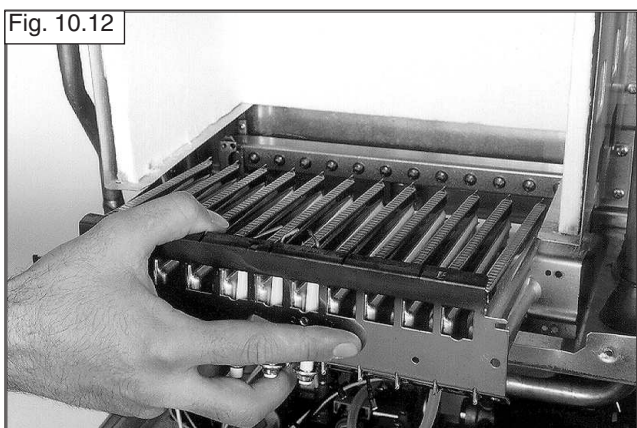
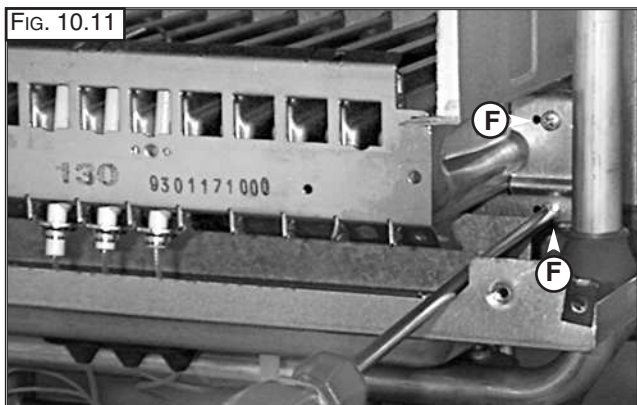

### 10.3.3 Removing the electrodes

Before carrying out this procedure, unscrew and slide the burner forward (see previous section).

1. Remove rubber gasket "G" (Fig. 10.13);
2. To remove the detection electrode disconnect the cable at its connection point close to the P.C.B. (Fig. 10.14);
3. Remove screw "H" (Fig. 10.15);
4. Gently slide the electrode downward (Fig. 10.16).

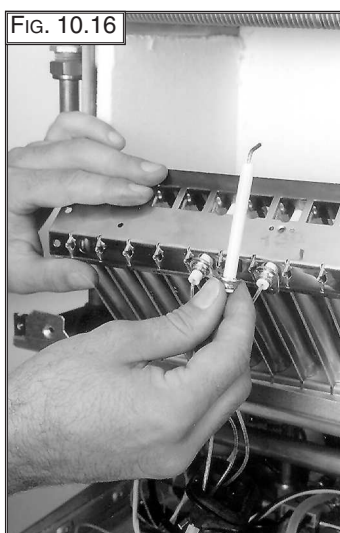
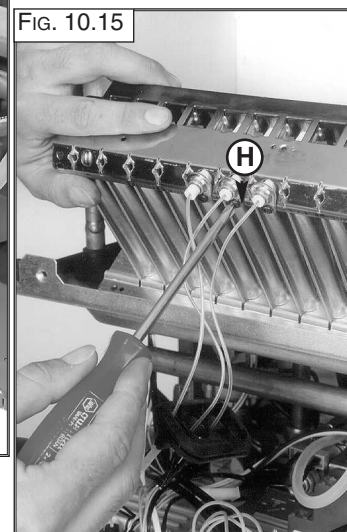
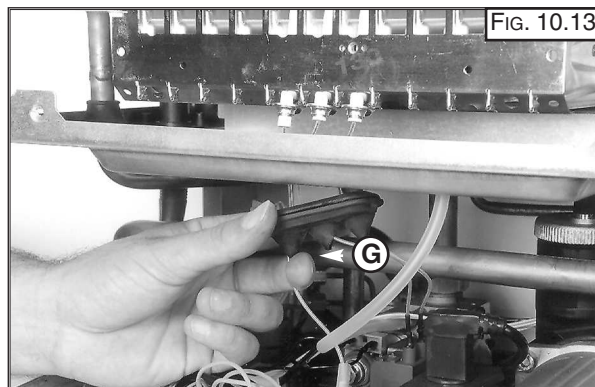

To replace, repeat the steps in reverse order, paying particular attention to the following:

- a - Centre the electrode in the positioning hole carefully, otherwise the electrode may break;
- b - Ensure that the left hand and right hand electrodes are located the correct way round (facing each other), to give the correct spark gap;
- c - Check that the cables have been connected correctly;
- d - Check that the rubber gasket seals the cable/ electrode connection point completely.

# Servicing Instructions

## 10.3.4 Removing the main heat exchanger

1. Drain the boiler of water;
2. Remove the overheat thermostat sensor, D.H.W. sensor and heating sensor "I" (Fig. 10.17);
3. Release the four connection nuts "J" connecting the exchanger to the flow and return pipes (Fig. 10.18);
4. Pull it straight out (Fig. 10.19).

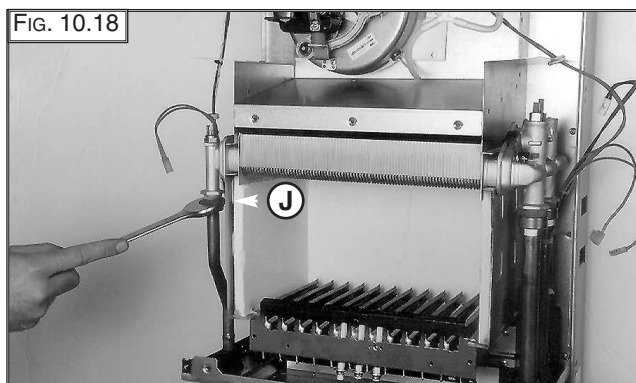
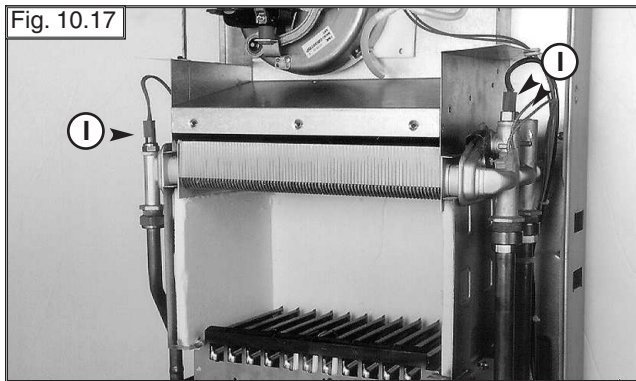

## 10.3.5 Removing the air pressure switch

1. Disconnect the electrical connections "K" and silicone pipes "L" from their connection points (Fig. 10.20);
2. Remove screws "M" on the top of the sealed chamber (Fig. 10.21);
3. Lift out the air pressure switch (Fig. 10.22);
4. Unscrew to remove the switch from the plate.

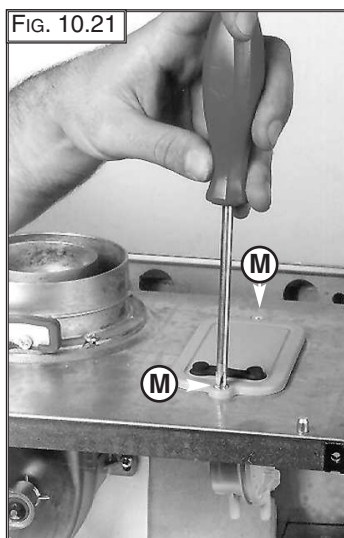
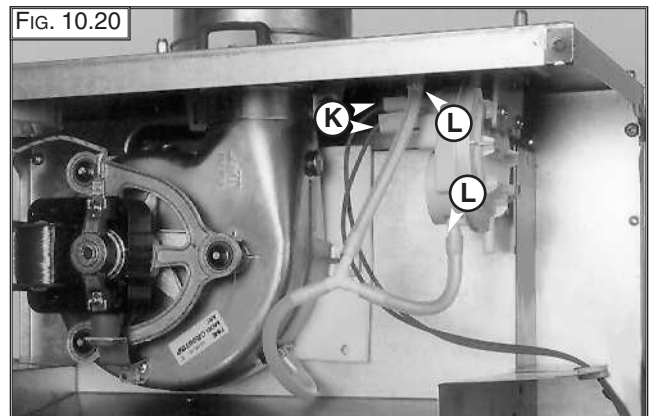

# Servicing Instructions

## 10.3.6 Removing the fan

1. Disconnect electrical connections "N" and silicone pipe "O" (Fig.10.23);
2. Remove screw "P" and remove the fan collar clamp "Q" (Fig. 10.24);
3. Remove screws "R" (Fig. 10.25);
4. Remove fan and mounting plate (Fig. 10.26).

FIG. 10.23

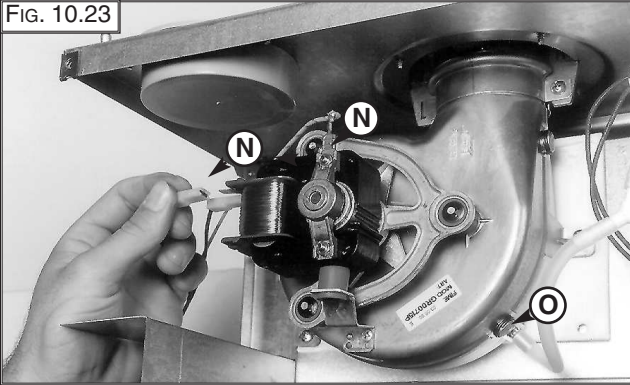

FIG. 10.24

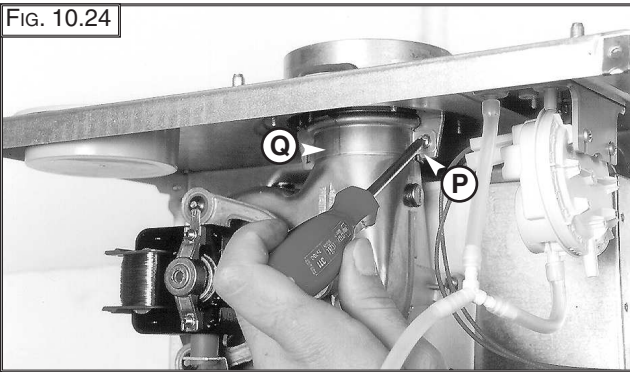

FIG. 10.25

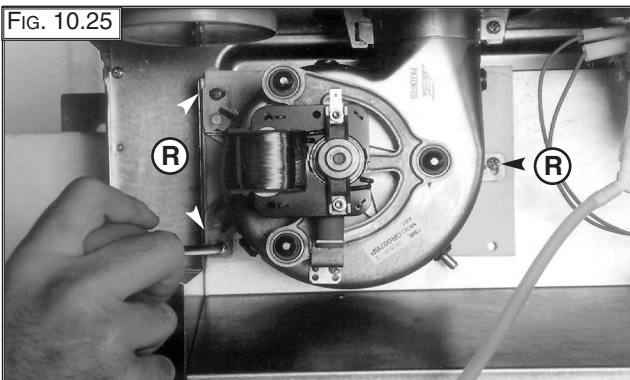
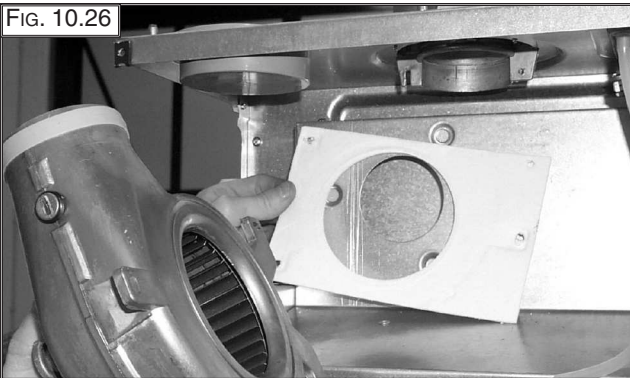

FIG. 10.26



## 10.4 Access to the Gas Valve

### 10.4.1. Removing the spark generator

1. Disconnect ignition leads "S" by pulling upward (Fig. 10.27);
2. Remove the screw "T" (Fig. 10.28);
3. Remove the spark generator by pulling forward from the gas valve (Fig. 10.29).

FIG. 10.27

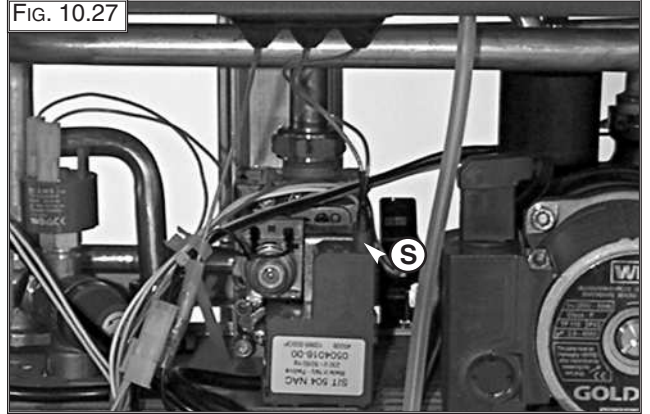

FIG. 10.28

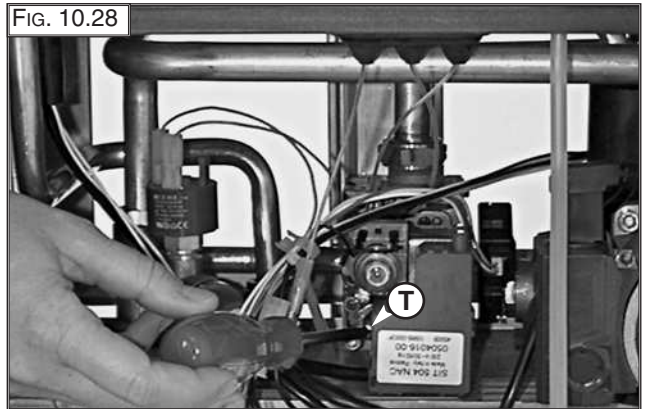
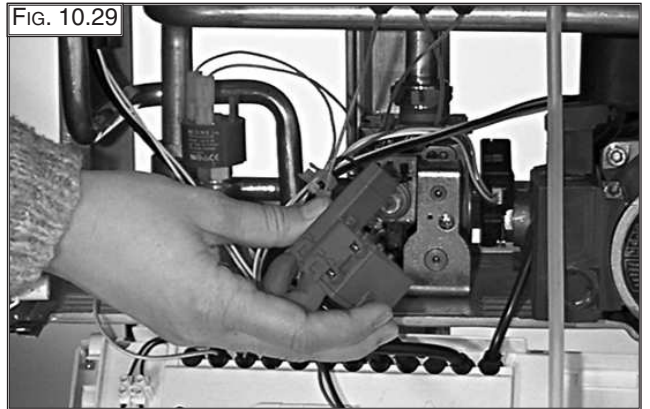

FIG. 10.29



# Servicing Instructions

## 10.4.2 Removing the gas valve

**Important!** Before removing the gas valve, ensure the gas supply is turned off.

1. Disconnect all the cables from the solenoid and modereg;
2. Remove the spark generator (see previous section);
3. Release the nuts "U" (Fig. 10.30);
4. Remove the screws "V" from the bottom of the gas valve (Fig. 10.31);
5. Remove the gas valve (Fig. 10.32).

Fig. 10.30

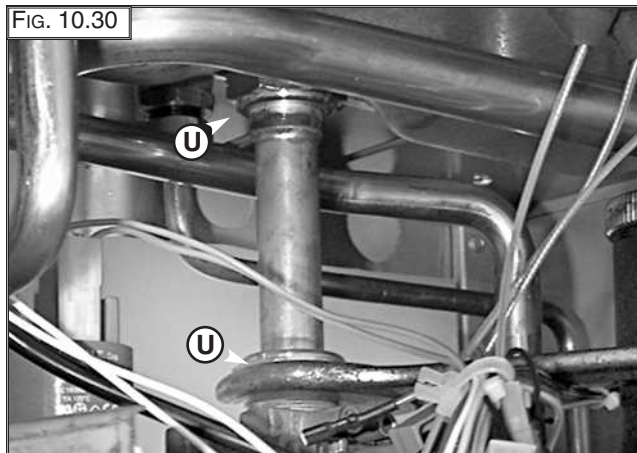

Fig. 10.31

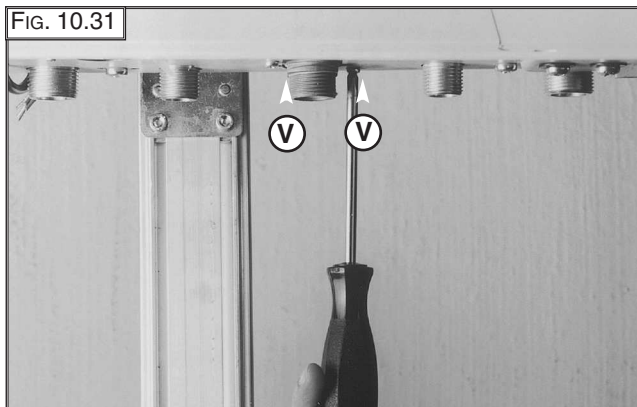
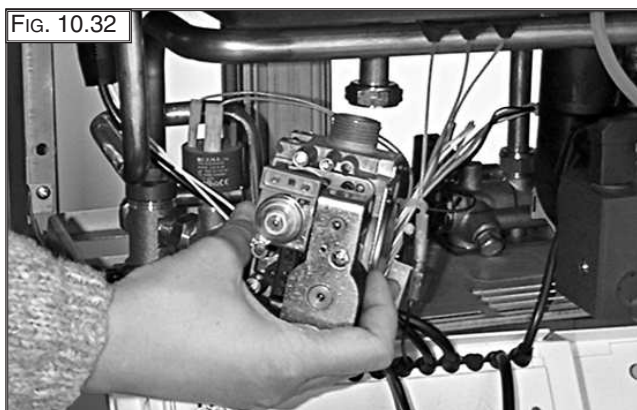

Fig. 10.32



## 10.5 Access to the Water Circuit

**Important!** Before any component is removed, the boiler must be drained of all water.

### 10.5.1 Removing the low water pressure switch

1. Remove the low water pressure switch electrical connections "W" (Fig. 10.33);
2. Unscrew the low water pressure switch by using a spanner on the nut;
3. Remove the low water pressure switch

Fig. 10.33



### 10.5.2 Removing the safety valve

1. Disconnect the discharge pipe work from below the boiler;
2. Unscrew and remove the valve "X" (Fig. 10.34).

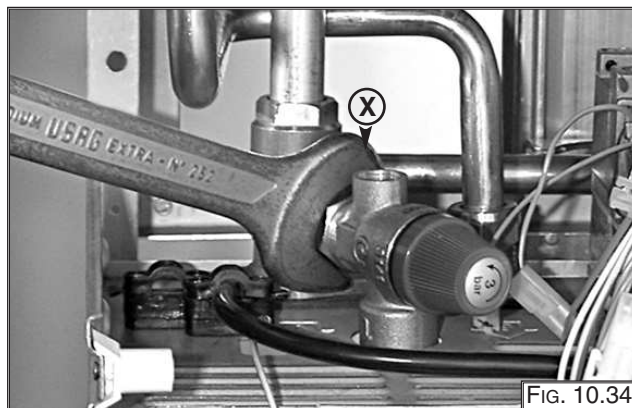
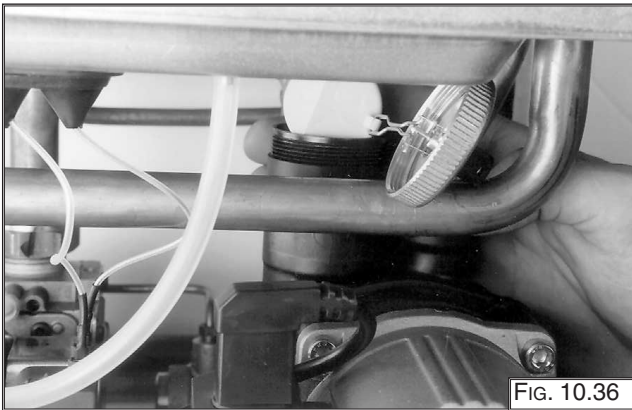
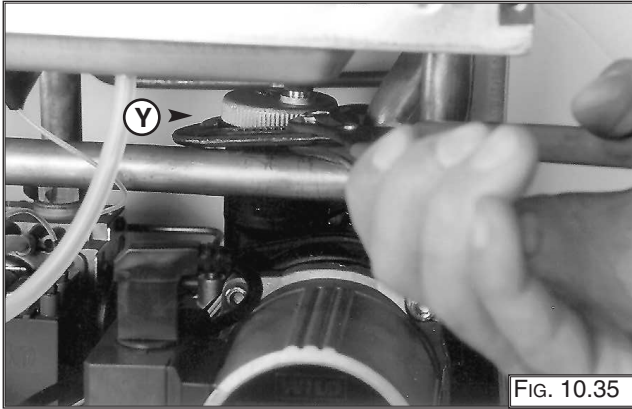

Fig. 10.34

# Servicing Instructions

## 10.5.3 Removing the automatic air vent

1. Unscrew valve top "Y" (FIG. 10.35);
2. Remove valve complete with float (FIG 10.36).



## 10.5.4 Removing the pump

1. Remove the U-clip "Z" (FIG. 10.37);
2. Remove the retaining clip "A1" (FIG. 10.38);
3. Release the nut "C1" (FIG. 10.39);
4. Remove the pipe "D1" (FIG. 10.40);
5. Remove the screws "E1" (FIG. 10.41);
6. Remove the pump.

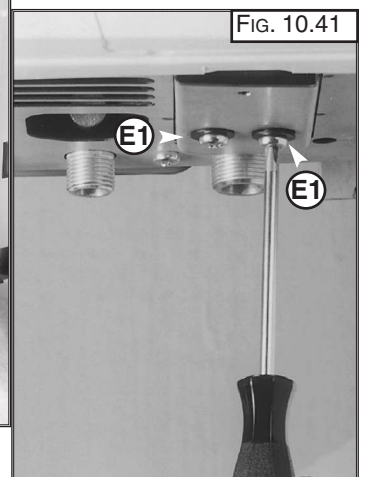
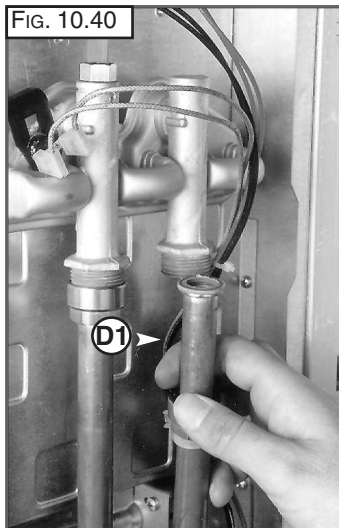
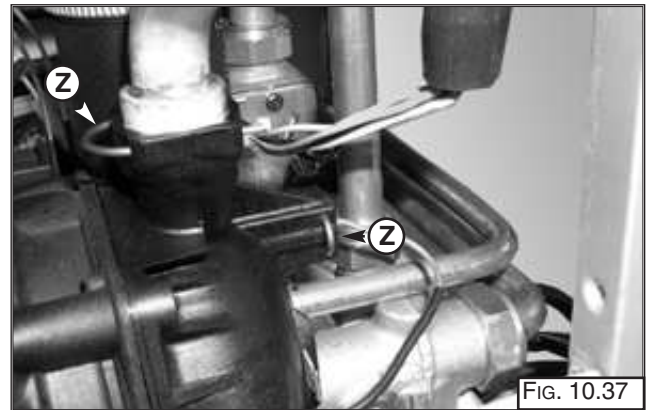

# Servicing Instructions

## 10.5.5 Removing the pressure gauge

1. Remove the U-clip "F1" (FIG. 10.42)
2. Remove the pressure gauge coupling (FIG. 10.42);
3. Push the pressure gauge through the control panel from the rear (FIG. 10.43).

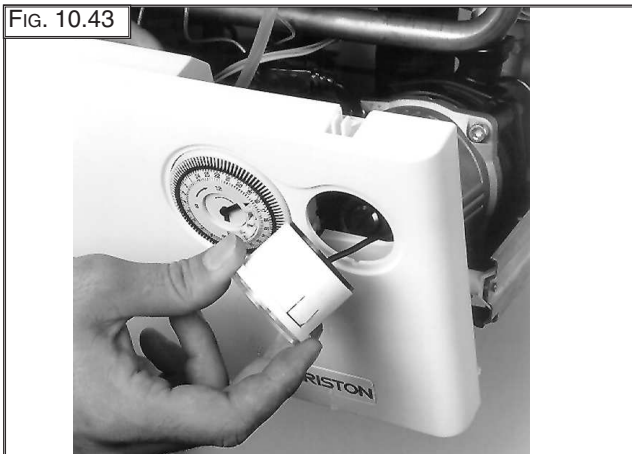
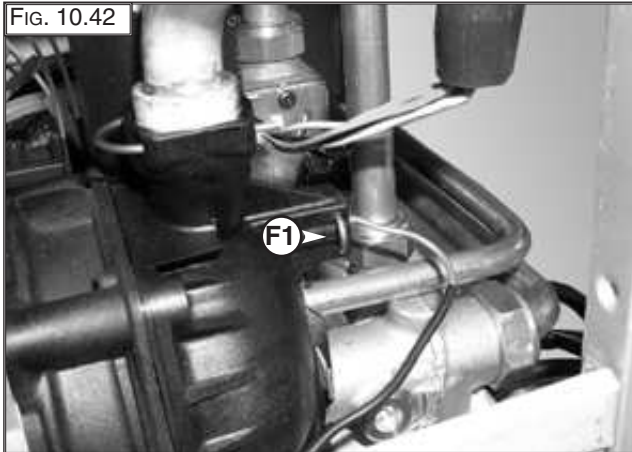

## 10.5.6 Removing the expansion vessel

1. Release nuts "G1" and remove the gas pipe (FIG. 10.44);
2. Release nut "H1" (FIG. 10.45);
3. Remove back-nut "I1" (FIG. 10.46);
4. Remove the expansion vessel (FIG. 10.47).

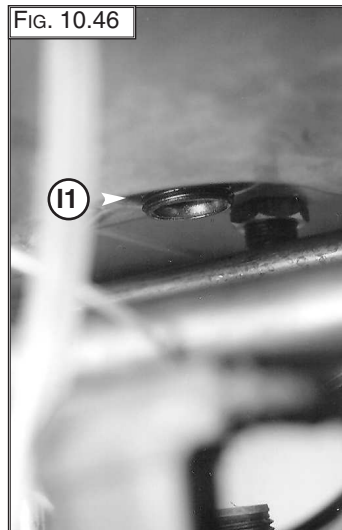
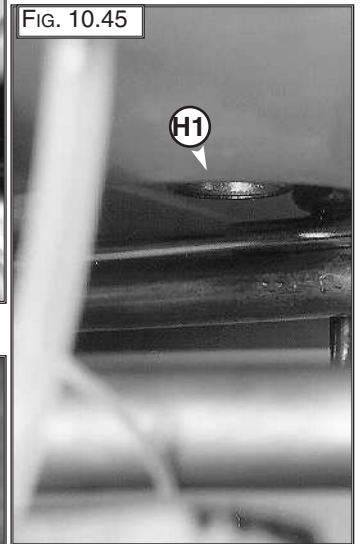
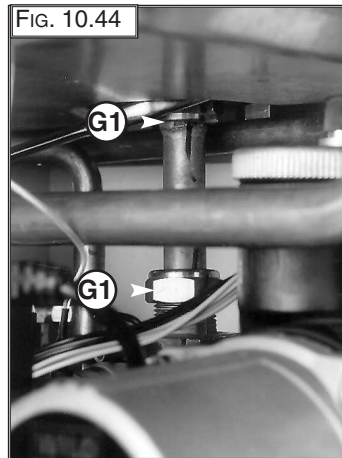

# Servicing Instructions

## 10.5.7 Removing the overheat thermostat

1. Disconnect the overheat thermostat electrical connections "J1" (FIG. 10.48);
2. Then remove the thermostat from its mounting by releasing the securing clip (FIG. 10.49 /10.50).

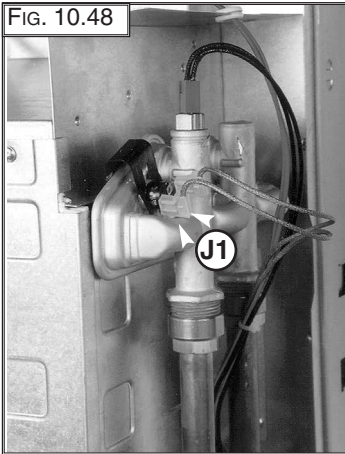

## 10.5.8 Removing the heating temperature sensor (N.T.C.)

1. Pull off the electrical connector and unscrew the sensor probe using a suitable spanner (FIG. 10.51).

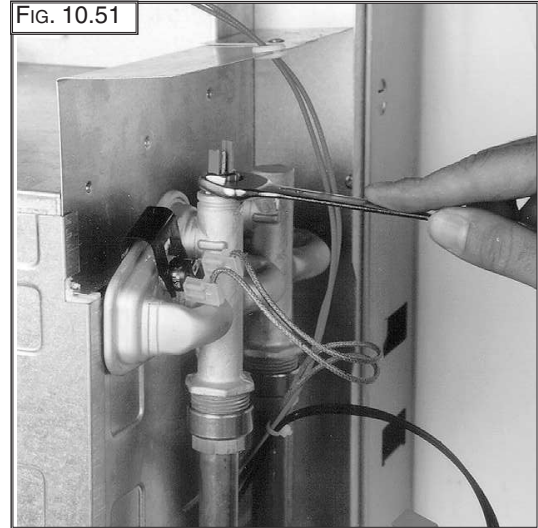

## 10.5.9 Removing the D.H.W. temperature sensor (N.T.C.)

1. Pull off the electrical connector and unscrew the sensor probe using a suitable spanner (FIG. 10.52).

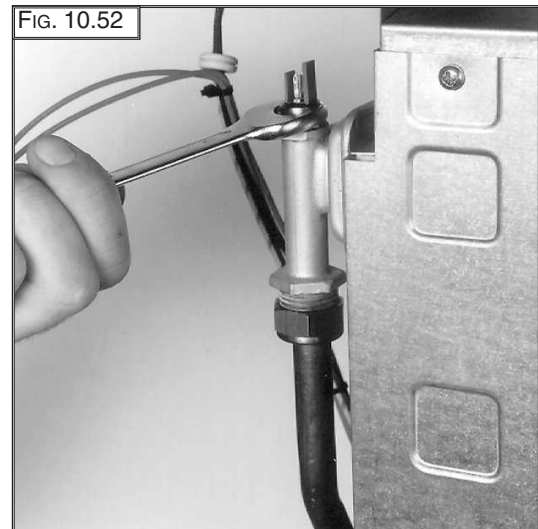



# Servicing Instructions

## 10.5.10 Removing the D.H.W. flow switch

1. Unplug the electrical connector "M1" (FIG. 10.53);
2. Release nut "N1" (FIG. 10.54);
3. Release the nut "O1" (FIG. 10.55) and remove the D.H.W. flow switch.

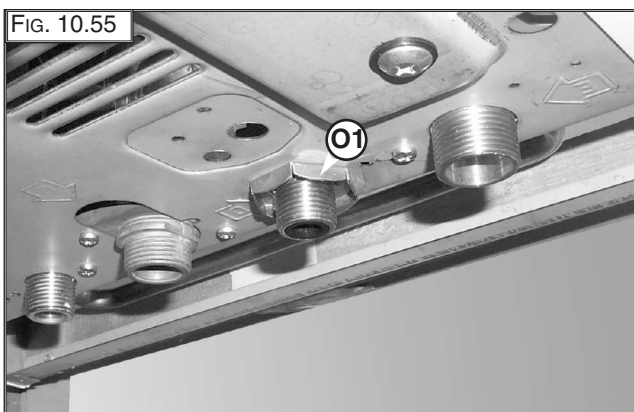
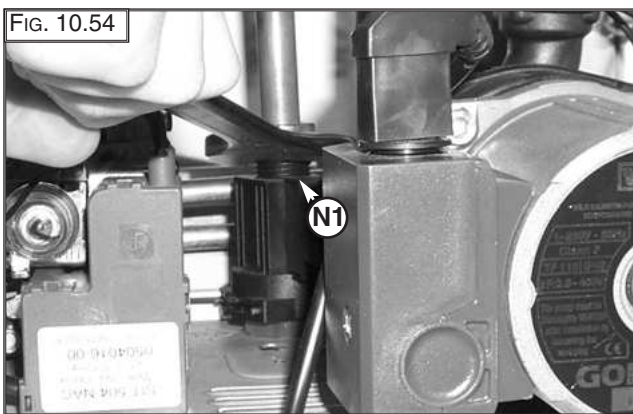
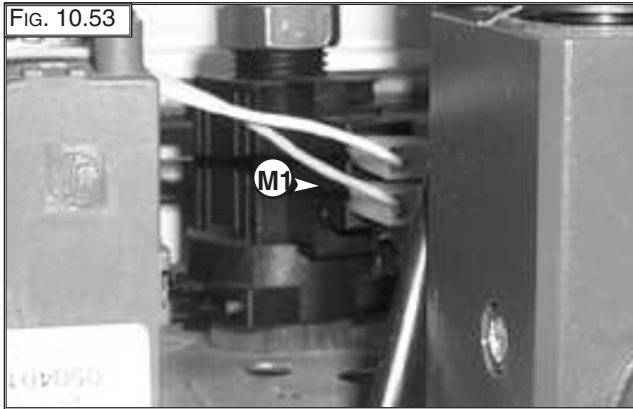

## 10.6 Access to the Control System

**Important!** Isolate the electrical supply to the boiler before accessing the control panel.

### 10.6.1 Checking the fuses

1. Remove the inspection cover on the reverse of the control panel (FIG. 10.56);
2. Remove the fuses (FIG. 10.57).

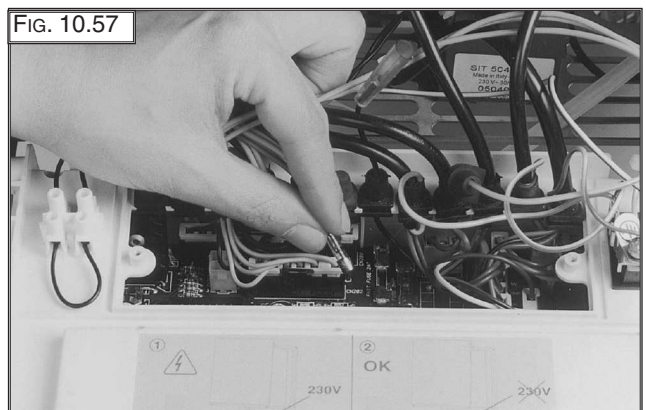
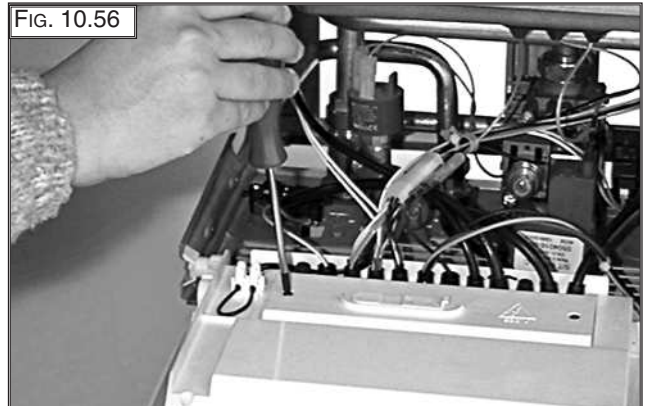

# Servicing Instructions

## 10.6.2 Removing the time clock

1. Disconnect the electrical connections "P1" from the clock (Fig. 10.58);
2. Remove screws "Q1" (Fig. 10.9);
3. Lift out the time clock from the control panel (Fig. 10.60).

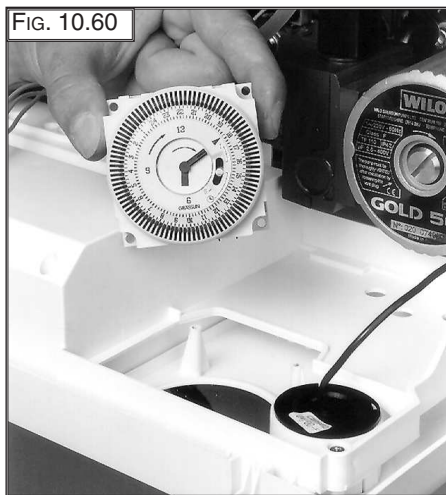
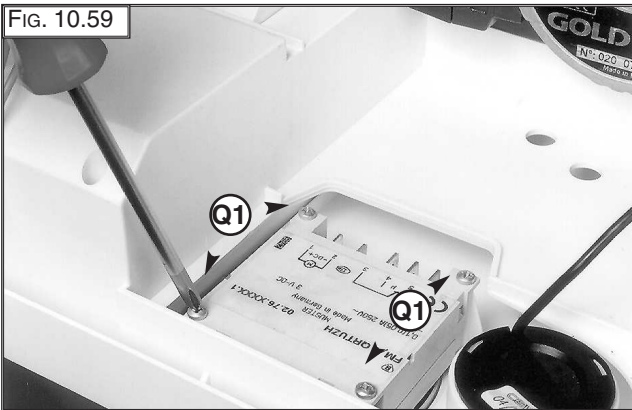
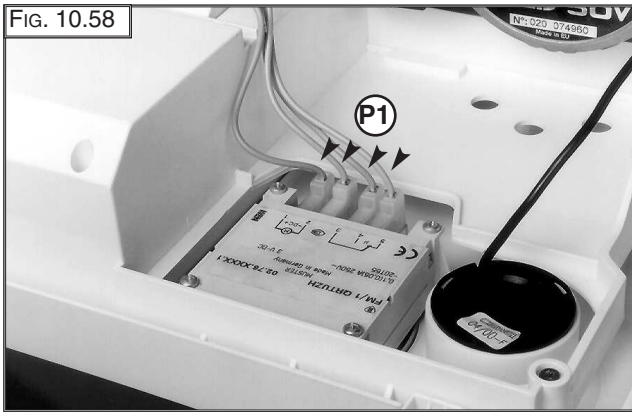

## 10.6.3 Removing the P.C.B.

1. Isolate electricity;
2. Remove the inspection cover from the reverse of the control panel;
3. Unplug all electrical connections from the P.C.B.
4. Remove the screws "R1" (Fig. 10.61);
5. Separate the facia panel from the rear of the control panel ;
7. Remove the screws "S1" and remove the P.C.B. (Fig. 10.62).

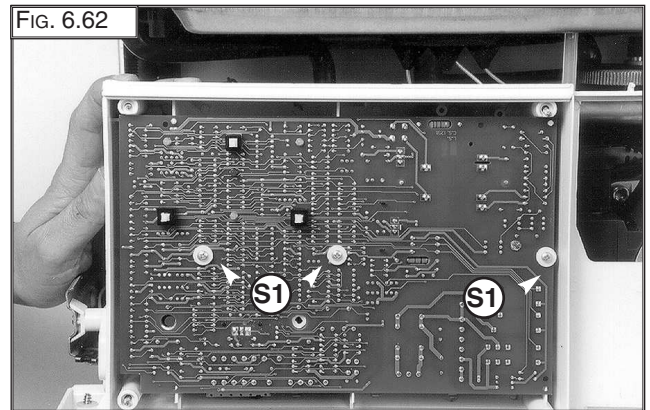
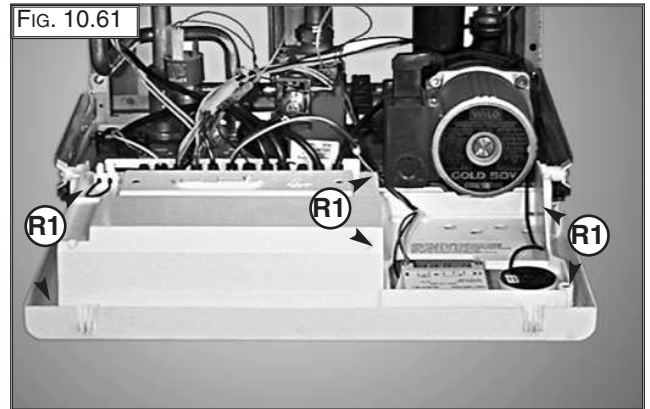

# 11. FAULT FINDING

## 7.1 Fault Finding Guide (Flow-charts)

These fault finding guides are not exhaustive. However, it is possible to detect and correct many defects by using the standard fault finding diagrams described in this chapter, ensure these guides are carried out in the set order.

To ensure that the external controls do not interfere with the fault finding, disconnect the wires from the terminal block on the rear of the control panel and provide a solid link between the terminals.

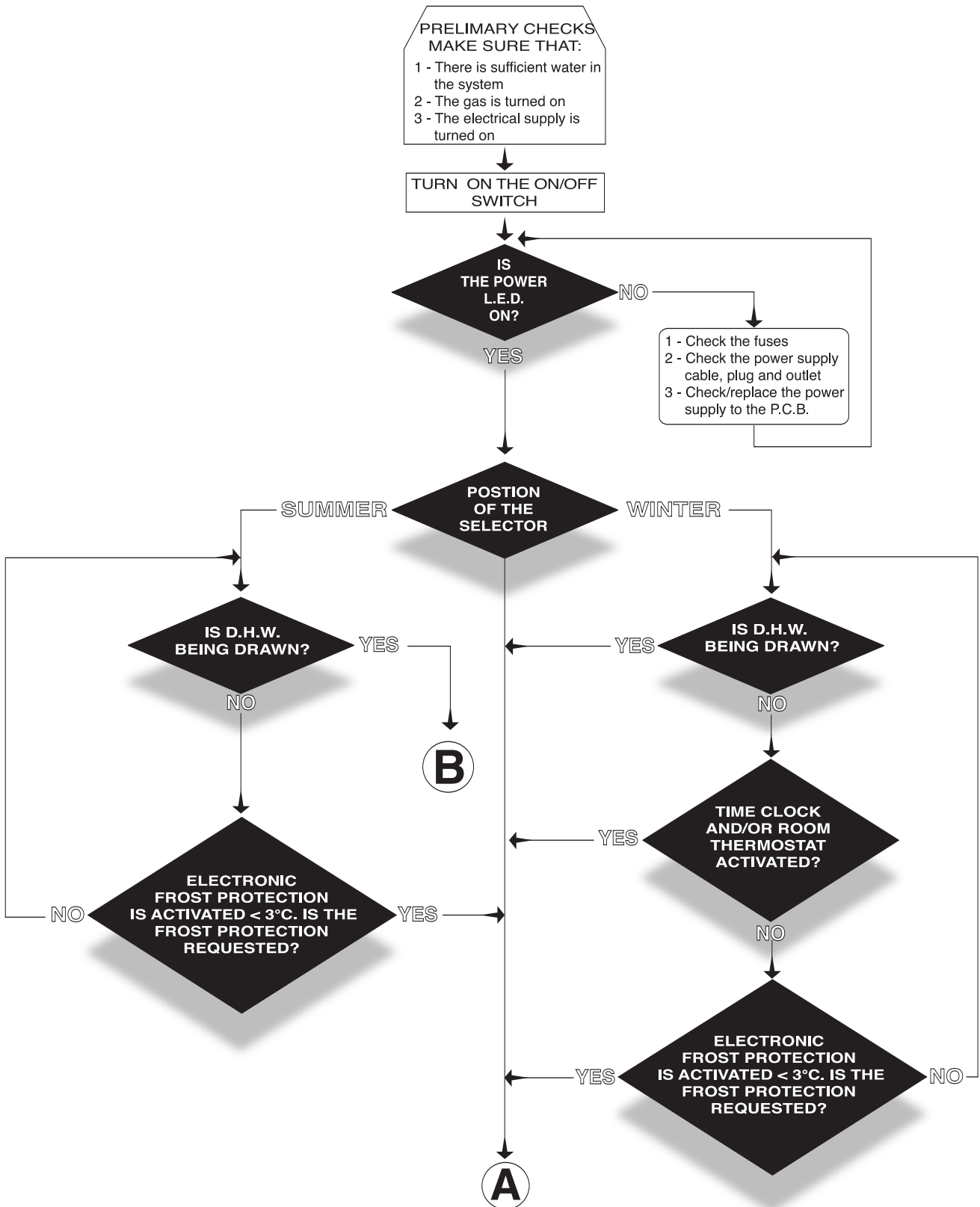

---

---

# Fault Finding

---

---

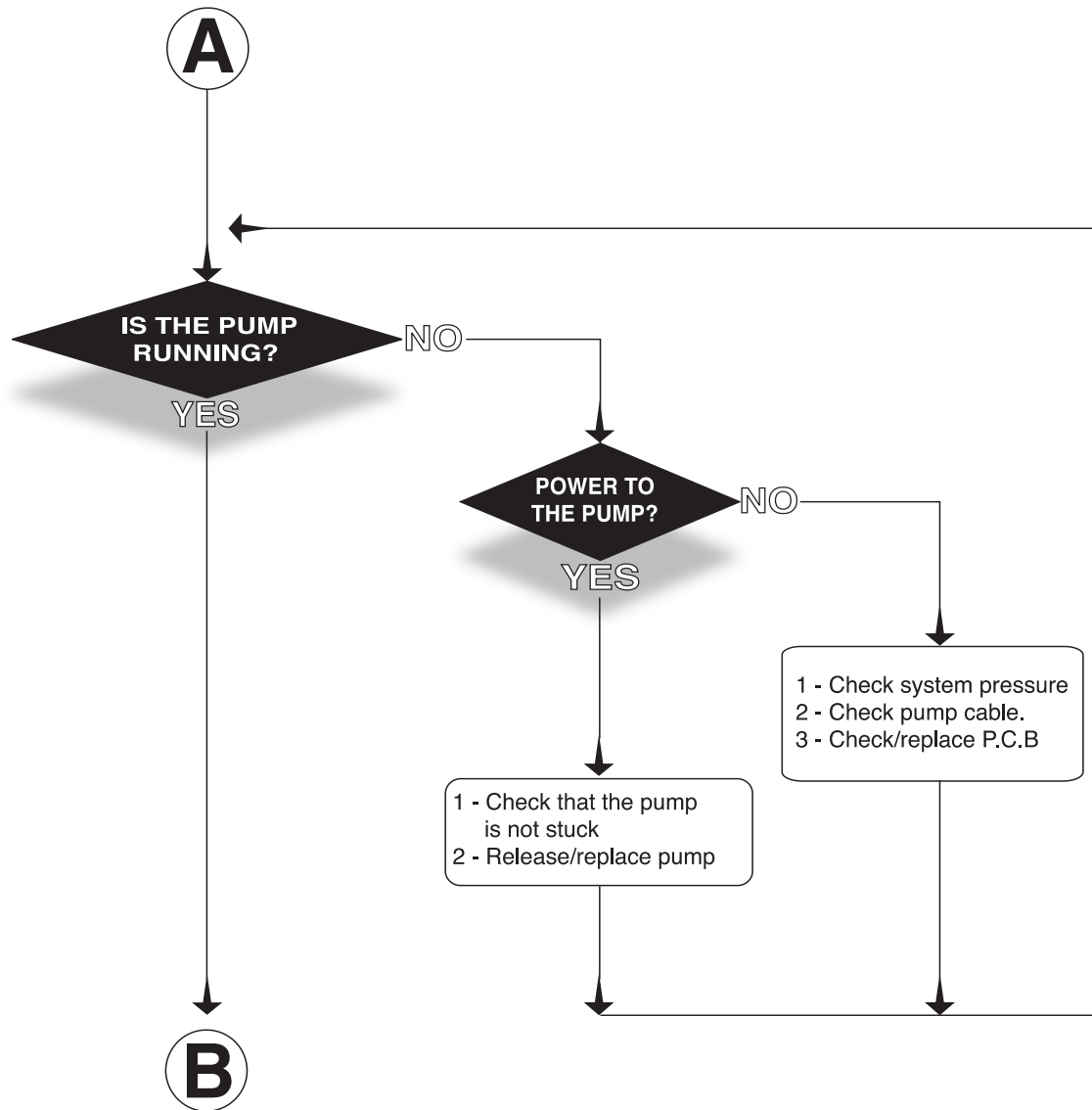

# Fault Finding

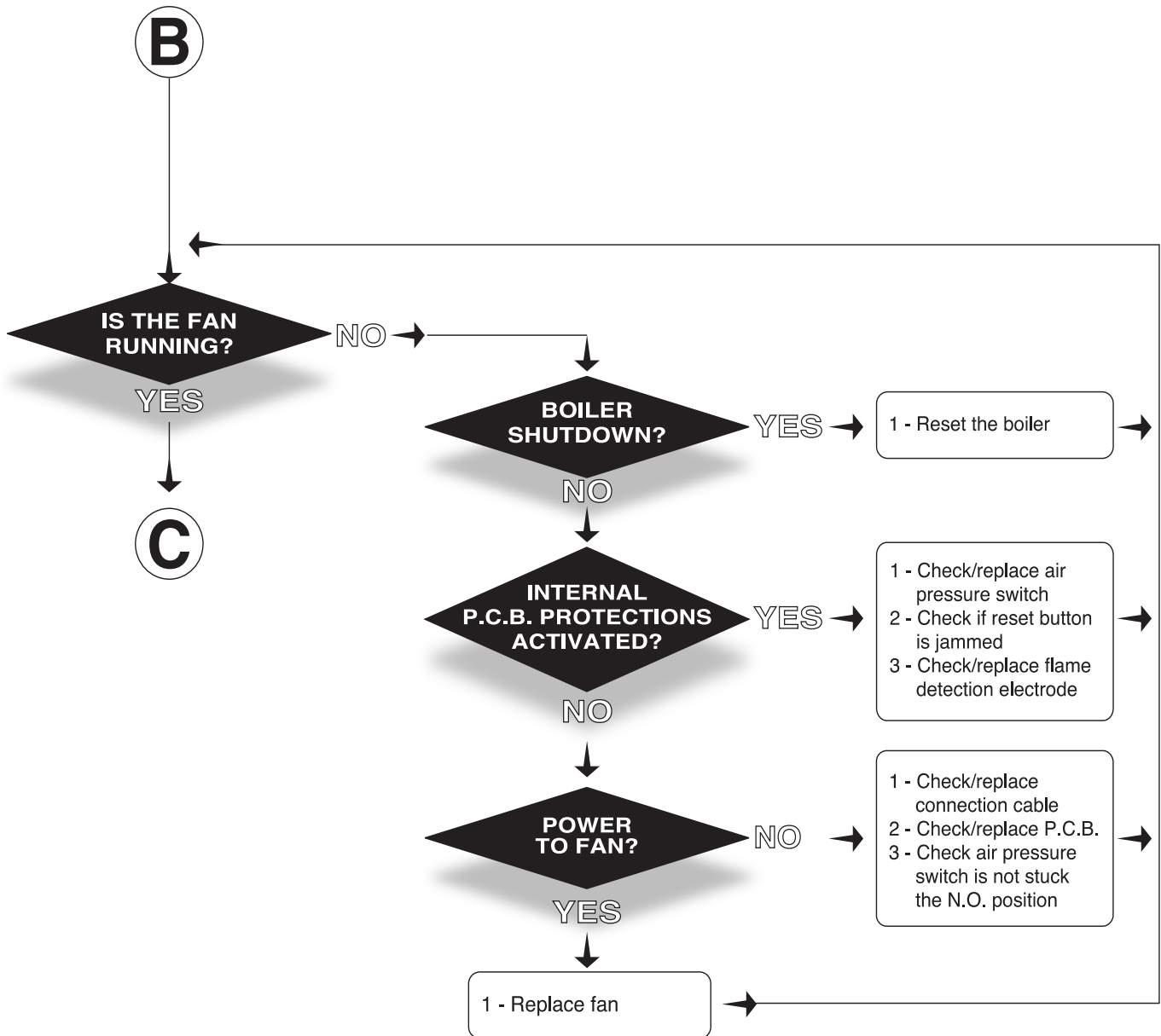

# Fault Finding

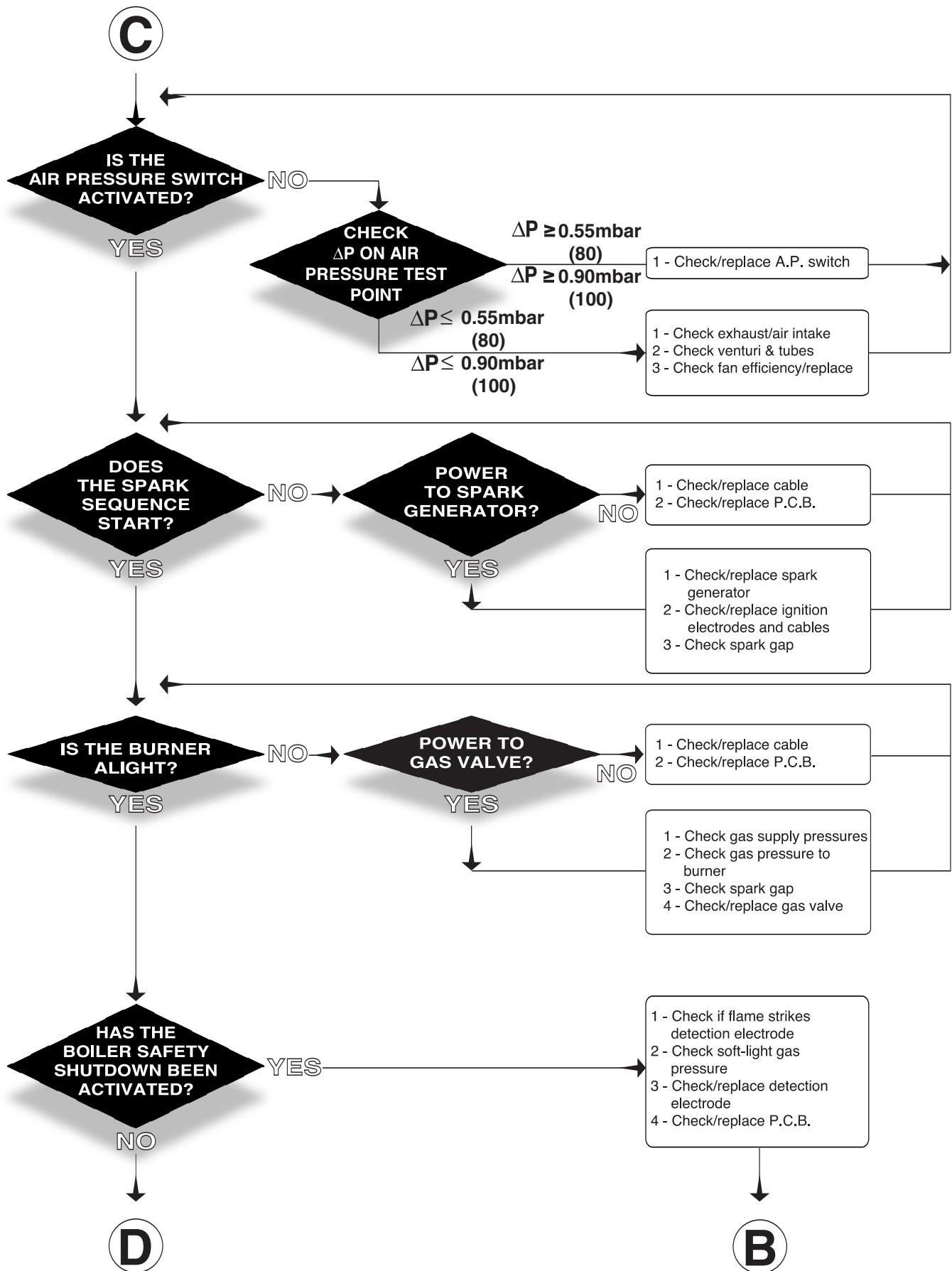

# Fault Finding

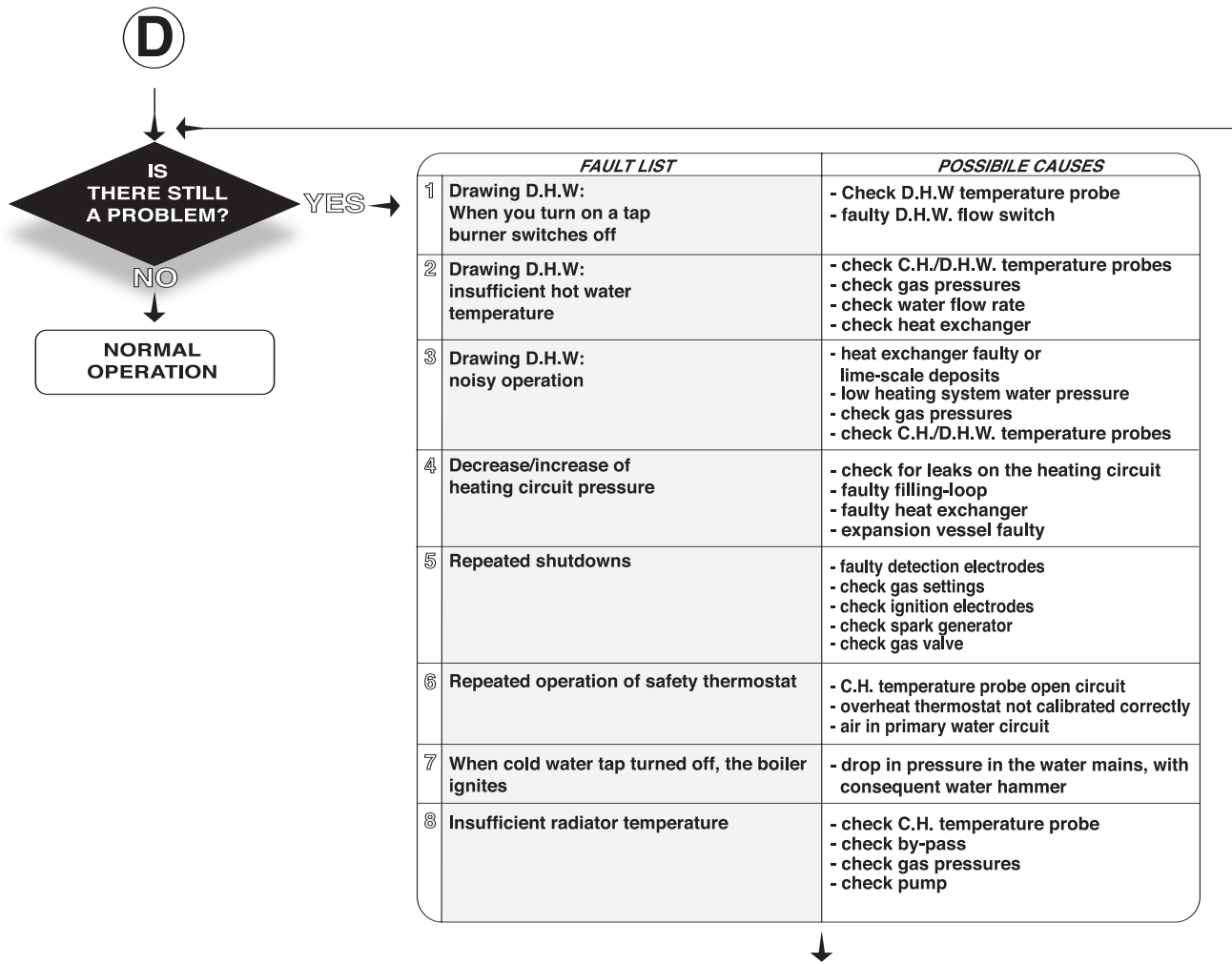

# 12. SHORT SPARE PARTS LIST

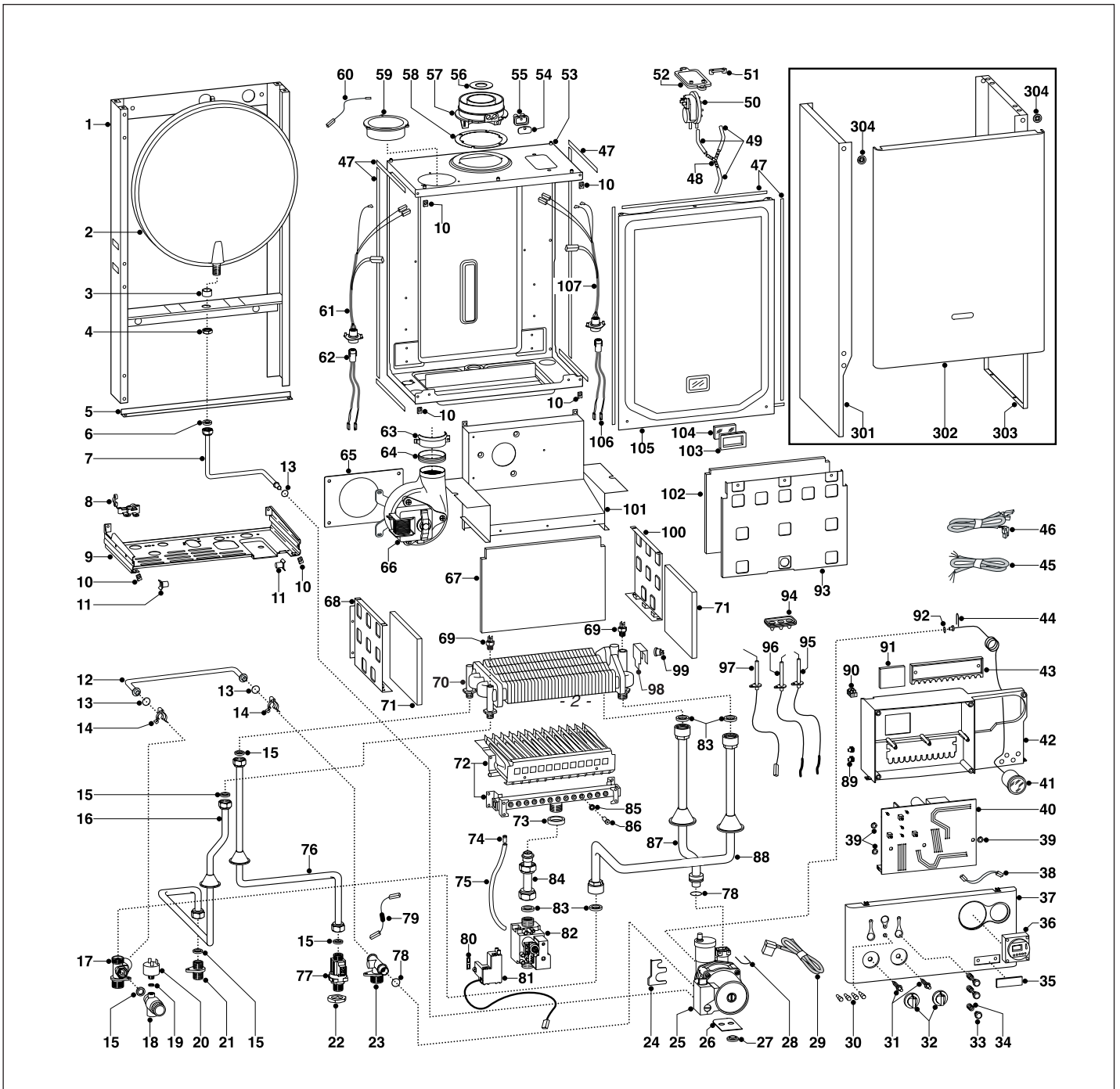



## Short Spares Parts List

Key no.	G.C. part no.	Description	Part No.
2	E61 468	Expansion vessel	998616
6	164 282	Gasket 3/8"	573521
15	164 229	Gasket 1/2"	573528
18		Safety valve (1/4" 3 bar)	998447
19	164 261	Gasket 1/4"	569390
20		Pump pressure switch	995903
23		Return group	996047
25A	E61 490	Pump	998836
25B		Pump	999091
36		Time clock	999599
40A		P.C.B. (T2 MFFI)	999724
40B		P.C.B. (27 MFFI)	65100248
41	E61 520	Pressure gauge	999245
50A		Air pressure switch	998484
50B		Air pressure switch	571651
64		Gasket (Fan)	995349
66A		Fan (23 kW)	999397
66B		Fan (27 kW)	998894
69		Temperature probe	998458
70		Exchanger	998619
72A	E61 547	Burner 12 ramp (natural gas)	996158
72B		Burner 13 ramp (natural gas)	995991
77		D.H.W. Flow Switch	996072
78	E61 483	O-ring	998424
80		Gasket	574279
81A		Spark Generator	999919
81B		Spark Generator	65100249
82A	E61 485	Gas valve (SIT 845 SIGMA)	997089
83	164 225	Gasket 3/4"	573520
86		Burner jet (natural gas 1.30)	998433
92		Gasket	998517
95A	E61 565	Electrode (ignition R.H.)	998623
95B		Electrode (ignition R.H.)	65100251
96A	E61 567	Electrode (ignition L.H.)	998622
96B		Electrode (ignition L.H.)	65100250
97	E61 569	Detection electrode	998624
99	E25 425	Thermostat (overheat)	996065
321	E61 665	Burner jet 1.30 full kit (natural gas)	998716
322	E61 667	Burner jet 0.77 full kit (LPG)	998717

## 13. TECHNICAL INFORMATION

	<i>Excalibur 80</i>	<i>Excalibur 100</i>
CE Certification	63AU4547	0694BM3512
Heat Input max/min kW	25.6/11.0	29.3/11.0
Heat Output max/min kW	23.7/9.6	27/9.3
Efficiency of Nominal Heat Input %	92.5	92
Efficiency at 30% of Nominal Heat Input %	90.5	88.8
Heat Loss to the Casing ( $\Delta T=50^{\circ}\text{C}$ ) %	1.0	1.3
Flue Heat Loss with Burner Operating %	6.5	6.7
Flue Heat Loss with Burner Off %	0.4	0.4
Max Discharge of Products of Combustion (G20) Kg/h	51	57.7
Residual Discharge Head mbar	0.96	1.41
Consumption at Nominal Capacity(G20) m <sup>3</sup> /h	2.72	3.10
Gas Consumption after 10 Minutes* (15°C, 1013 mbar) (G30-G31) m <sup>3</sup>	0.32	0.36
Temp. of exhaust fumes at nominal capacity °C	126	148.5
CO <sub>2</sub> Content %	7.0	7.1
O <sub>2</sub> Content %	8.0	8.0
CO Content ppm	38	53
Minimum Ambient Temperature °C	+5	+5
Head Loss on Water Side (max) ( $\Delta T=20^{\circ}\text{C}$ ) mbar	200	200
Residual Head of System bar	0.25	0.25
Heating Temperature max/min °C	82/42	82/42
Domestic Hot Water Temperature (approx) max/min °C	54/36	56/36
D.H.W. Flow Rate $\Delta T=35^{\circ}\text{C}$ l/min	9.7	11.0
D.H.W. Minimum Flow Rate l/min	2.5	2.5
Pressure of Domestic Hot Water max/min bar	6/0.2	6/0.2
Expansion Vessel Capacity l	6	6
Expansion Vessel Pre-load Pressure bar	1	1
Maximum Water Content of System l	130	130
Maximum Heating Pressure bar	3	3
Nominal Pressure Natural Gas (G20) mbar	20	20
LPG (G30-G31) mbar	30-37	28-37
Electrical Supply V/Hz	230 / 50	230/50
Power Consumption W	135	155
Protection Grade of Electrical System IP	X4D	X4D
Internal Fuse Rating	FAST 2 AT	FAST 2 AT
Weight Kg	39	41
<b>G.C. Number</b>	<b>47-116-30</b>	<b>47-116-31</b>

\*Calculated at 70% maximum output

Manufacturer: **Merloni TermoSanitari S.p.A.**

**Technical Service Hot Line: 0870 241 8180**

**Customer Service Help Desk: 0870 241 8175**