



**MADEIRA SOLAR
KRBS
12 - 24 - 28 - 32**



IST 03 C 870 - 01

INSTALLATION, USE AND MAINTENANCE



CE

fondital
BE INNOVATIVE

EN

Translation of the
original instructions (in
Italian)

Dear Sirs,

thank You for choosing and buying one of our products. Please read these instructions carefully in order to properly install, operate, and maintain the product.



WARNING

- **We inform users that:**
 - **Boilers shall be installed by an authorised company under the requirements set forth by the prevailing rules, in full compliance with the prevailing regulations and standards.**
 - **Anyone entrusting installation to an unqualified installer will be subject to administrative sanctions.**
 - **Boilers must be maintained by qualified personnel only, under the requirements set forth by the prevailing rules.**
-

We hereby inform you that certain models, versions and/or accessories relevant to the products this manual refers to, might not be available in some countries.

Therefore, it is recommended to contact the manufacturer or the importer in order to get the necessary information about the actual availability of such models, versions and/or accessories.

The manufacturer reserves the right to modify the products and/or its components as deemed necessary, in any moment and without prior notice.

This instruction manual is available in two languages, Italian and English, without prejudice to the prevalence of Italian language in case of differences in translation and/or dispute on construction of the text.

General notes for installing and maintenance technicians, and users

This instruction manual is an integral and essential part of the product. It shall be supplied by the installer to the user who shall keep it carefully to consult it whenever necessary.

This document shall be supplied together with the equipment in case the latter is sold or transferred to others.



DANGER

**This equipment has been manufactured to be connected to a room heating system and to a DHW distribution system.
Any other use shall be considered unsuitable and dangerous for people, animals, and/or property.**

The equipment shall be installed in compliance with the prevailing standards and in accordance with the manufacturer's instructions specified in this manual: the manufacturer will not be held responsible for injuries to people and animals and/or damages to property resulting from an incorrect installation.

Damage and/or injury caused by incorrect installation or use and/or damage and/or injury due to non-observance of the manufacturer's instructions shall release the manufacturer from any and all contractual and extra-contractual liability.

Before installing the boiler, check that the technical data correspond to the requirements for its correct use in the system.

Check that the boiler is intact and it has not been damaged during transport and handling. Do not install equipment which is clearly damaged and/or faulty.

Do not obstruct the air intake openings.

Only original accessories or optional kits (including the electric ones) are to be installed.

Properly dispose of the packaging as all the materials can be recycled. The packaging must therefore be sent to specific waste management sites.

After removing the packaging, make sure that its elements (clips, plastic bags, foam polystyrene etc.) are not left within the reach of children as they are potential hazard sources.

In the event of failure and/or faulty functioning, switch off the boiler. Do not attempt to make repairs: contact qualified technicians.

Original parts must be used for all repairs to the boiler.

Non-observance of the above requirements may affect the safety of the boilers and endanger people, animals and/or property.

This appliance is not intended for use by persons (including children) with reduced physical, sensory or mental capabilities, or lack of experience and knowledge, unless they have been given supervision or instruction concerning use of the appliance by a person responsible for their safety.

Children should be supervised to ensure that they do not play with the appliance.



WARNING

**The boiler must be serviced periodically as indicated in the relevant section of this manual.
Appropriate boiler maintenance ensures efficient operation, environment preservation, and safety for people, animals and objects.
Incorrect and irregular maintenance can be a source of danger for people, animals and property.**

The user is strongly advised to have the boiler serviced and repaired by a qualified Service Centre.

In the event of long periods of inactivity of the boiler, disconnect it from the electrical power mains and close the gas cock. **The electronic antifreeze function will not be operative with the device disconnected from the electric power supply and gas cock closed.**

Should there be a risk of freezing, add antifreeze: it is not advisable to drain the system as this may result in damage; use specific anti-freeze products suitable for multi-metal heating systems.



DANGER

With gas fired boilers, take the following measures if you smell gas:

- Do not turn on or off electric switches and do not turn on electric appliances.
- Do not ignite flames and do not smoke.
- Close the main gas cock.
- Open doors and windows.
- Contact a Service Centre, a qualified installer or the gas supply company.

Never use a flame to locate a gas leak.

The boiler is designed for installation in the countries indicated on the technical data plate: installation in any other country may be a source of danger for people, animals and/or property.

The manufacturer will bear no contractual and tortious liability for failure to comply with all the instructions above.

Rapid operating instructions



The following instructions will help you to switch the boiler on quickly and regulate it for immediate use.





WARNING

It is presumed that the boiler has been installed by a qualified installer, it has been commissioned and is ready to operate correctly. If any accessories have been fitted on the boiler, these instructions will not cover them. You will therefore have to refer to the full boiler instructions as well as to the specific instructions for the accessories.

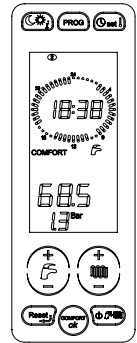

This manual contains full details of how the boiler works, and full operating and safety instructions.

1. Open the gas cock installed ahead of the boiler.
2. Turn the master switch installed ahead of the boiler **ON**; the boiler display turns on.
3. If you do not wish to activate the CH function, press the  button until displaying the symbol : only the DHW function will be enabled.

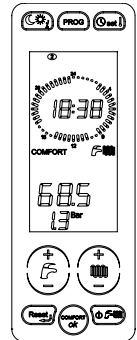

4. If you wish to activate both the heating and DHW functions, press the  button until displaying the symbol .



5. If you do not wish to activate the DHW function, press the  button until displaying the symbol : only the CH function will be enabled.
6. To enable water heater heating press  button, the display shows the writing "COMFORT" (if it was enabled, this operation disables it). Warning: if water heater heating is disabled, the boiler can still heat domestic water through the solar plant, of course only if the atmospheric conditions allow it (see par. *Water heater freeze protection function* on page 24).
7. To set the domestic hot water temperature, press **DHW +/-** buttons.
8. To set the heating water temperature, press **CH +/-** buttons.
9. Set the desired temperature on the (optional) ambient thermostat in the building. The boiler is now ready to operate.

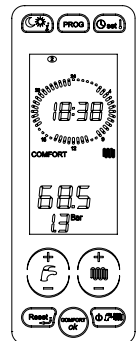

If the boiler shuts down, press  button.

If boiler does not resume its operation after three attempts, contact a qualified Service Centre.

1.	<i>Instructions for the user</i>	10
1.1	<i>Control panel</i>	10
1.2	<i>Interpreting boiler status from display indications</i>	13
1.3	<i>Selecting the operating mode</i>	15
1.4	<i>Adjusting heating and DHW temperature</i>	16
1.5	<i>Comfort function enable/disable</i>	16
1.6	<i>Time setting</i>	17
1.7	<i>"Day temperature" and "night temperature" setting</i>	18
1.8	<i>"Manual" programme setting</i>	19
1.9	<i>"Automatic" programme setting</i>	19
1.10	<i>Heating and water heater programme mode</i>	20
1.11	<i>Parameter display</i>	21
1.12	<i>Failures that cannot be reset</i>	21
1.13	<i>Resume boiler function</i>	21
1.14	<i>Boiler operation</i>	22
1.15	<i>Boiler shut-down</i>	26
1.16	<i>Maintenance</i>	29
1.17	<i>Notes for the user</i>	29
2.	<i>Technical features and dimensions</i>	30
2.1	<i>Technical features</i>	30
2.2	<i>Dimensions</i>	32
2.3	<i>Boiler layouts</i>	33
2.4	<i>Key components</i>	35
2.5	<i>Boiler layouts</i>	36
2.6	<i>Operating data</i>	37
2.7	<i>General characteristics</i>	38
2.8	<i>ERP and Labelling data</i>	40
3.	<i>Instructions for the installer</i>	44
3.1	<i>Installation standards</i>	44
3.2	<i>Choosing where to install the boiler</i>	44
3.3	<i>Installing the boiler</i>	45
3.4	<i>Boiler room ventilation</i>	45
3.5	<i>Air intake and flue gas venting system</i>	46
3.6	<i>Checking combustion efficiency</i>	52
3.7	<i>Connection to gas mains</i>	53
3.8	<i>Hydraulic connections</i>	53
3.9	<i>Solar collector probe installation</i>	55
3.10	<i>Connection to electrical mains</i>	55
3.11	<i>Connection to ambient thermostat (optional)</i>	55
3.12	<i>Installation and operation with Open Therm Remote Control (optional)</i>	56
3.13	<i>TSP parameters</i>	59
3.14	<i>Filling the system</i>	64
3.15	<i>Starting up the boiler</i>	65
3.16	<i>Available head</i>	66
3.17	<i>Wiring diagrams</i>	69
3.18	<i>Adaptation to other gas types and burner adjustment</i>	81
4.	<i>Testing the boiler</i>	86
4.1	<i>Preliminary checks</i>	86
4.2	<i>Switching on and switching off</i>	86
5.	<i>Maintenance</i>	87
5.1	<i>Maintenance schedule</i>	87

5.2	Combustion analysis	88
6.	Decommissioning, disassembly and disposal	89
7.	Malfunctions, possible causes and solutions	90
7.1	Troubleshooting	90

Fig. 1 Control panel.....	10
Fig. 2 Mixing valve position (rear view)	23
Fig. 3 Filler cock.....	27
Fig. 4 Dimensions.....	32
Fig. 5 Hydraulic diagram	33
Fig. 6 Hydraulic diagram	33
Fig. 7 Hydraulic diagram	34
Fig. 8 Key components.....	35
Fig. 9 Boiler operation diagram.....	36
Fig. 10 Installation examples	46
Fig. 11 Coaxial ducts C33.....	49
Fig. 12 Coaxial ducts C33 distance specs.....	49
Fig. 13 Coaxial ducts C43 - C53 - C83	51
Fig. 14 Coaxial ducts C43 - C53 - C83 distance specs.....	51
Fig. 15 Plugs position	52
Fig. 16 Hole position.....	52
Fig. 17 Connection to gas mains.....	53
Fig. 18 Condensate drain.....	54
Fig. 19 Thermoregulation curves	58
Fig. 20 Filling the solar plant	65
Fig. 21 Available head KRBS 12 - KRBS 24	66
Fig. 22 Available head KRBS 28	67
Fig. 23 Available head KRBS 32	67
Fig. 24 Available head KRBS-V-MV-Z-MZ high temperature zone.....	67
Fig. 25 Available head KRBS-V-MV-Z-MZ low temperature zone 1	68
Fig. 26 Available head KRBS-Z-MZ low temperature zone 2	68
Fig. 27 Available head solar circulation pump.....	68
Fig. 28 Wiring diagram KRBS	69
Fig. 29 Wiring diagram KRBS-M.....	71
Fig. 30 Wiring diagram KRBS-V	73
Fig. 31 Wiring diagram KRBS-MV	75
Fig. 32 Wiring diagram KRBS-Z	77
Fig. 33 Wiring diagram KRBS-MZ	79
Fig. 34 Intake pipe.....	83
Fig. 35 Mixer.....	83
Fig. 36 Mixer plastic body	83
Fig. 37 Assembling direction	83
Fig. 38 Adjusting CO2 value.....	85

Tab. 1 Displayable parameters with info button21
Tab. 2 Adjustment specifications 12 kW37
Tab. 3 Adjustment specifications 24 kW37
Tab. 4 Adjustment specifications 28 kW37
Tab. 5 Adjustment specifications 32 kW37
Tab. 6 General specifications38
Tab. 7 Combustion specifications 12 kW39
Tab. 8 Combustion specifications 24 kW39
Tab. 9 Combustion specifications 28 kW39
Tab. 10 Combustion specifications 32 kW39
Tab. 11 ERP and Labelling data - 12 kW40
Tab. 12 ERP and Labelling data - 24 kW41
Tab. 13 ERP and Labelling data - 28 kW42
Tab. 14 ERP and Labelling data - 32 kW43
Tab. 15 Boiler re-ignition temperature55
Tab. 16 Limits to be set for TSP parameters and default values in relation to boiler type (TSP0)57
Tab. 17 List of parameters - I59
Tab. 18 List of parameters - II60
Tab. 19 List of parameters - III61
Tab. 20 Solar parameter (with P17=2 or with supplementary board)62
Tab. 21 System check62
Tab. 22 Display only63
Tab. 23 Relationship between "Temperature and Nominal resistance" for temperature probes81
Tab. 24 Table84
Tab. 25 Flue CO2 content85
Tab. 26 Diameter of nozzles - diaphragms (mm)85

1. Instructions for the user

1.1 Control panel

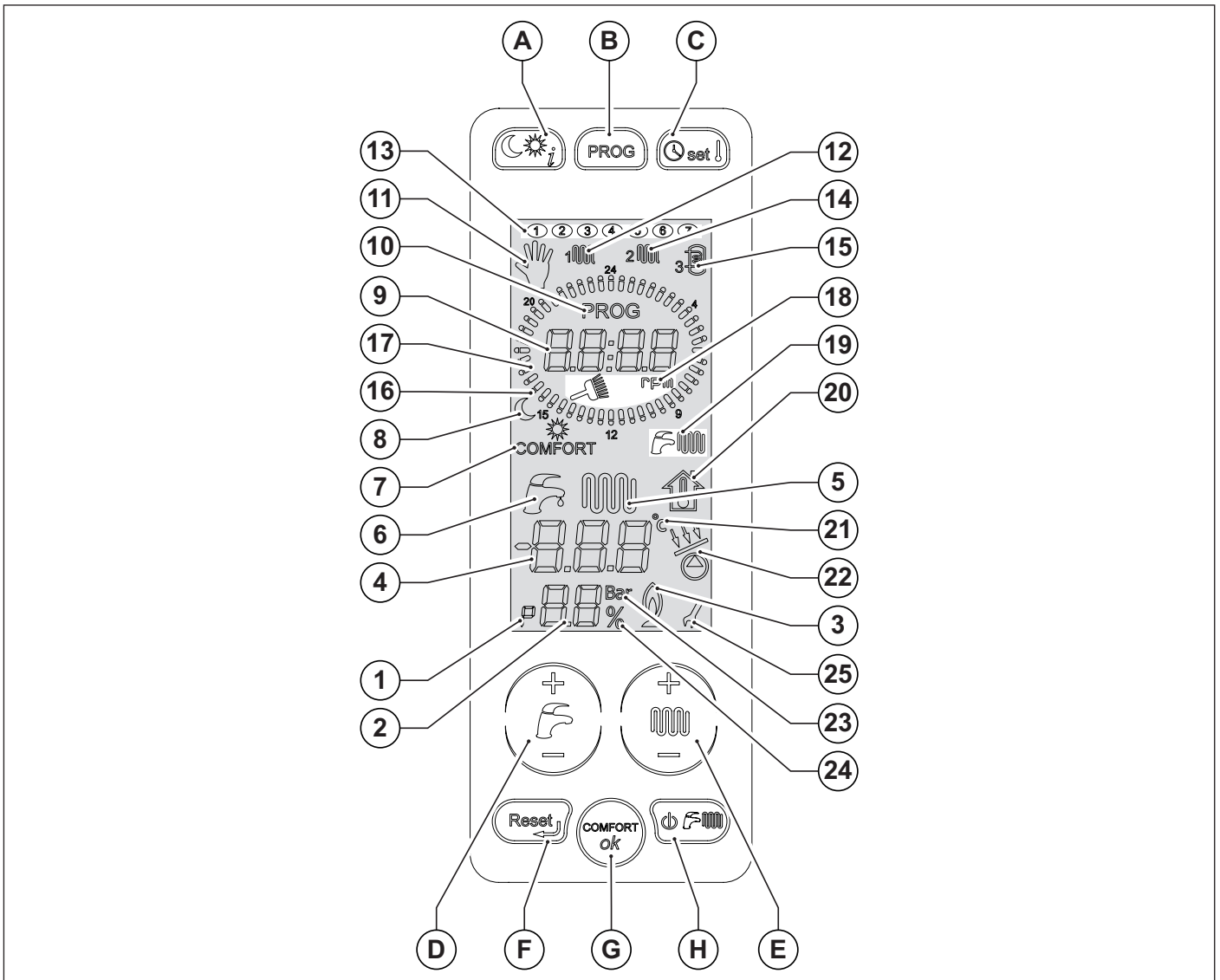



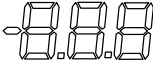



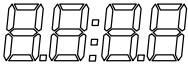















Fig. 1 Control panel

- A. Temperature selection (day/night) and information recall.
- B. Weekly programme for temperature zones and manual programme selection.
- C. Time and ambient temperature setting.
- D. Set the domestic hot water (DHW +/-).
- E. Set the heating water and the (CH +/-) settings.
- F. Alarm reset and back to the starting page during parameter selection.
- G. Water heater heating 24 hours a day enabling and confirmation button.
- H. Operating status selection.

To gain access to the interface, touch the display area. Once active, the interface enables all the keys. 15 seconds after the last key has been touched, the interface disables all the keys.

Ref.	Symbol	Steady on	Flashing
1		Indication of "parameter" inside the parameter menu	Not used
2		Displaying of the number of parameters, or of the system pressure, or of the burner power percentage	Not used
3		Lit flame indication	Not used
4		Indication of the temperatures and values of fault and shutdown parameters	Not used
5		A heating request is present	Displaying of the heating temperature set-point
6		A DHW request is present	Displaying of the DHW temperature set-point
7	COMFORT	Displaying of DHW "comfort" status wording ON = comfort enabled wording OFF = comfort disabled.	Not used
8		Current temperature (sun = day; moon = night)	Setting of the two temperatures associated with the sun and the moon
9		Display of current time/fan revolutions	Not used
10	PROG	Indicates if the unit is in time slot programming mode	Not used
11		Manual mode operation	Manual mode setting
12		Display of zone 1 heating programme	Edit zone 1 heating programme
13		Current day of the week	Edit day of the week
14		Display of zone 2 heating programme	Edit zone 2 heating programme
15		Display of water heater programme	Edit water heater programme
16		Night time temperature indication	Not used
17		Daytime temperature indication	All lights flashing: automatic mode setting
18	 rpm	Displaying of the flue cleaning function and of the "rpm" wording to show the number of revolutions per minute of the fan.	Indicates that you are accessing the flue cleaning function.
19		Symbols for instantaneous DHW, heating. Symbol: ON = function enabled OFF = function disabled.	Not used

Ref.	Symbol	Steady on	Flashing
20		Not used	Displaying of the fictitious ambient temperature set-point
21		Indication of the centigrade degrees	Not used
22		Solar pump or solar valve active	Not used
23	Bar	Indication of system pressure measurement unit	Not used
24		Percentage indication	Not used
25		During parameter editing, the wrench symbol stays on until the set datum is confirmed.	Not used

1.2 Interpreting boiler status from display indications

1.2.1 Normal operation

Boiler switch in OFF mode.

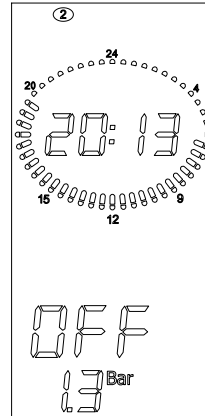

Boiler switch in SUMMER or WINTER mode or CH ONLY.

No active function.

The flow temperature and the heating system pressure are displayed.

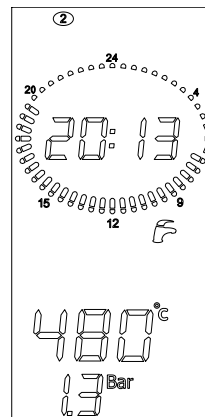

SUMMER

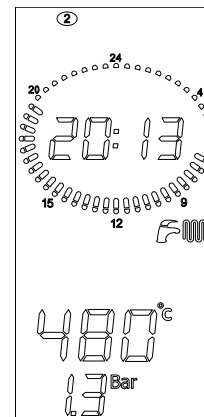

WINTER

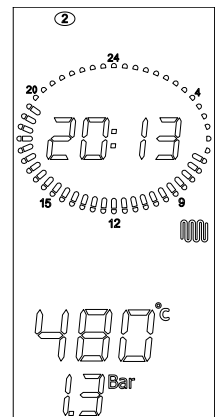

CENTRAL HEATING ONLY

Boiler switch in SUMMER or WINTER mode.

The boiler is heating the top part of the water heater.

DHW temperature displayed (water heater top part).

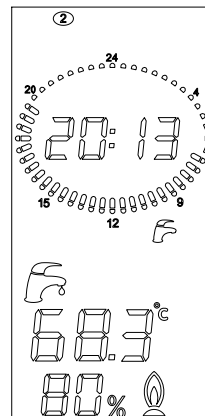

SUMMER

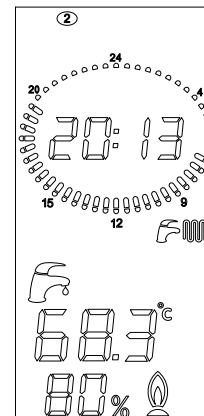

WINTER

Boiler switch in WINTER mode or CH ONLY.

CH function active.

The flow water temperature is displayed.

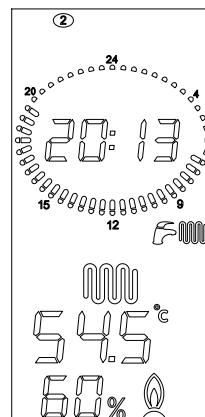

WINTER

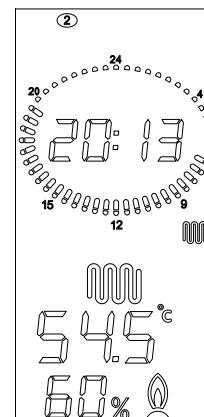

CENTRAL HEATING ONLY

Boiler switch in SUMMER or WINTER mode.

Water heater temperature maintenance function enabled (COMFORT enabled).

The flow temperature and the heating system pressure are displayed.

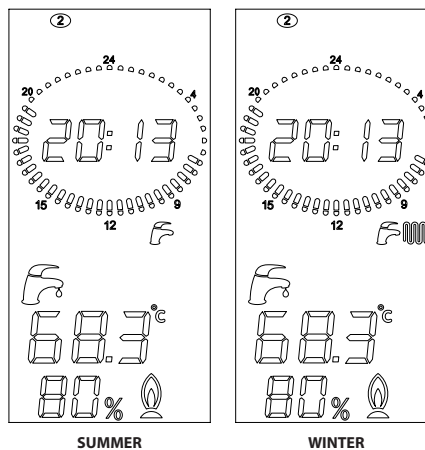

Boiler switch in SUMMER or WINTER mode or CH ONLY.

Solar pump active or solar valve (M version) active.

The flow temperature and the heating system pressure are displayed.

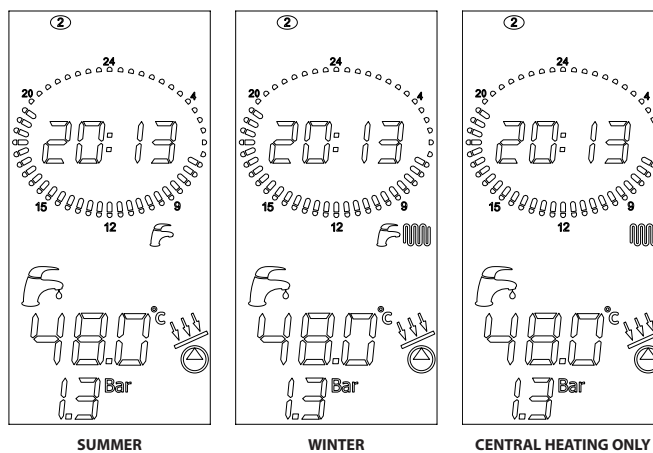

1.2.2 Malfunction

To identify any malfunctions, refer to paragraph *Troubleshooting* on page 90.

1.3 Selecting the operating mode

Whenever  key is pressed, the "SUMMER", "WINTER", "CH ONLY", "OFF" modes are enabled in sequence. At this stage, all buttons are enabled.

1. "OFF" operating status

When the "OFF" mode is enabled, no function is active.

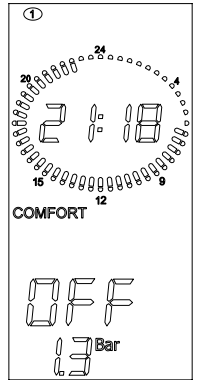

2. "SUMMER" operating status

When the "SUMMER" mode is enabled, only the DHW production function is active.

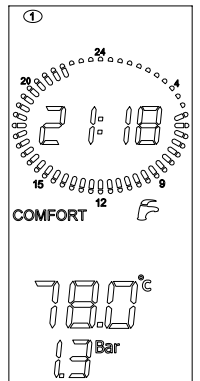

3. "WINTER" operating status

When the "WINTER" mode is enabled, both DHW and CH functions are active.

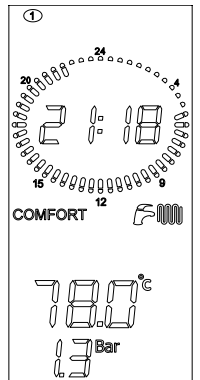

4. "CH ONLY" operating status

When the "CH ONLY" mode is enabled, only the heating water production function is active.

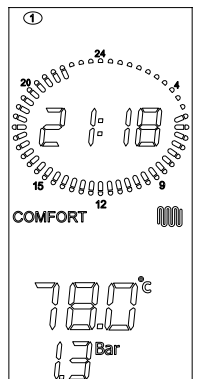

1.4 Adjusting heating and DHW temperature

Press **DHW +/-** button to select the desired domestic hot water temperature (water heater maintenance temperature).

During selection,  icon will flash.

In the phase in which the icon is flashing, only the buttons to adjust the temperature are enabled.

As soon as button is released, icon will continue flashing for approx. 3 seconds, and temperature value will flash as well.

After this time, value is stored and display standard operation will be restored.

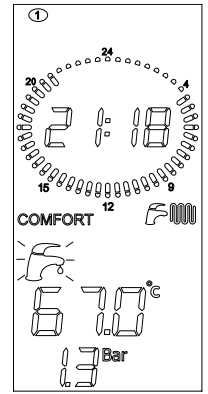

Press **CH +/-** button to select the desired flow water temperature.

During selection,  icon will flash.

In the phase in which the icon is flashing, only the buttons to adjust the temperature are enabled.

As soon as button is released, icon will continue flashing for approx. 3 seconds, and temperature value will flash as well.

After this time, value is stored and display standard operation will be restored.

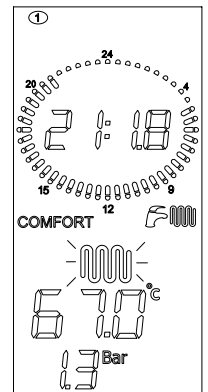

1.5 Comfort function enable/disable

This function keeps the water heater hot (top part) ignoring the existing water heater heating programming, if any (see par. *Heating and water heater programme mode* on page 20). When the "COMFORT" icon is on, the function is enabled. When it is off the function is disabled and the boiler follows the set water heater hour programming. If the "comfort" function is disabled and no programming is set, the boiler can still heat the domestic water naturally through the solar plant, if the atmospheric conditions allow it.

If "COMFORT" function is enabled ("COMFORT" icon ON), press "OK" button to disable it.

If "COMFORT" function is disabled ("COMFORT" icon OFF), press "OK" button to enable it.

Water heater heating, through the comfort function or programming, is carried out only if the boiler is in SUMMER or WINTER mode.

If the boiler is in CH ONLY or OFF operating mode the water heater is not heated.

1. "Comfort" function enabled
2. Press **OK**

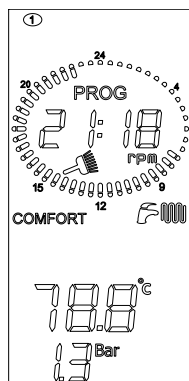

3. "Comfort" function disabled

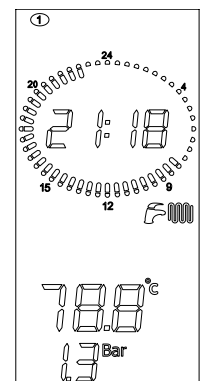

1.6 Time setting

1. To set time, minutes and day of the week, press .

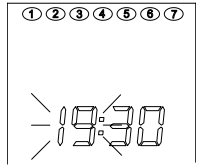

2. Flashing values can be edited by pressing **CH +/-** buttons. The first value to be modified is "HOURS".



3. Press **OK** to confirm the edited values and shift to next parameter. The second value to be modified is "MINUTES".
Flashing values can be edited by pressing **CH +/-** buttons.

4. Press  to access the day and night setting function described in the following paragraph.

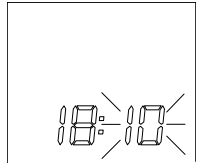

5. Press **OK** to confirm the edited values and shift to next parameter. The third value to be modified is "DAYS". Day of the week can be selected by pressing **CH +/-** buttons.

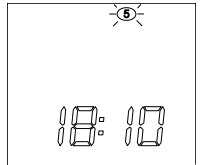

6. Press **OK** to confirm the edited values. Press  to quit the function and go back to starting page.

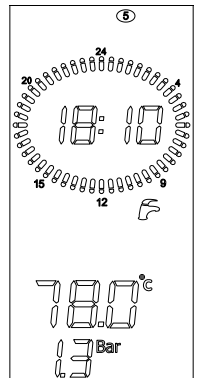

1.7 "Day temperature" and "night temperature" setting

When one or more ambient probes are connected to boiler electronic board, two levels of desired ambient temperatures can be set. Boiler will manage the heating request based on the set temperatures, as follows.

If no ambient probe is connected to the boiler, temperatures cannot be set.

"Day" temperature is identified by the symbol ☀, while "night" temperature by the symbol ☾.

The "day temperature" is active when bars are on, while "night" temperature is active when bars are off.

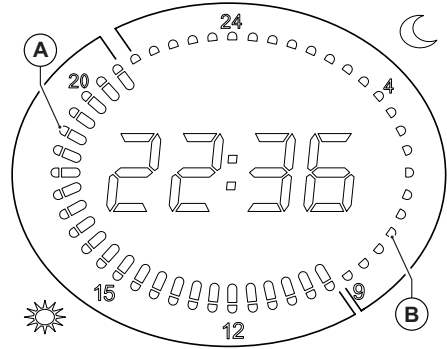

A bars on
B bars off

1. Press  twice to access the "day temperature" setting mode.

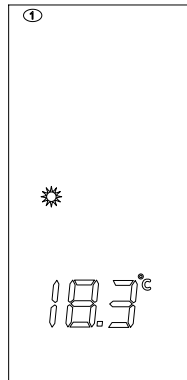

4. Press **CH +/-** buttons to edit "day temperature" values.

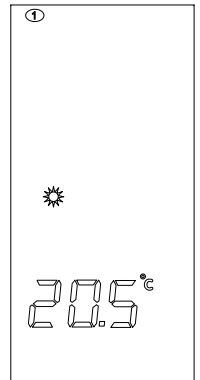

2. Press **OK** to confirm the edited values and enter the "night temperature" setting mode.

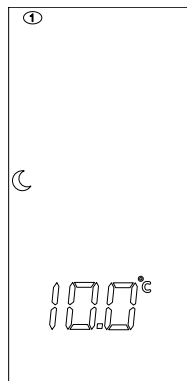

5. Press **CH +/-** buttons to edit "night temperature" values.

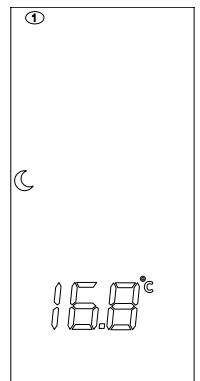

3. Press **OK** to confirm the edited values and quit the setting mode.

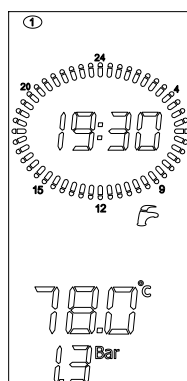

1.8 "Manual" programme setting

The "manual" mode selection indicated with symbol  , allows activating the heating function, 24 hours a day, in both zones at the "day temperature", disabling at the same time zone 1 and zone 2 programming. The water heater is heated according to the specific programme.

1. Press  to access the manual programme setting mode.

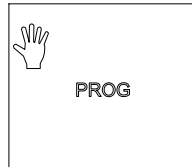

2. Press **OK** to confirm.

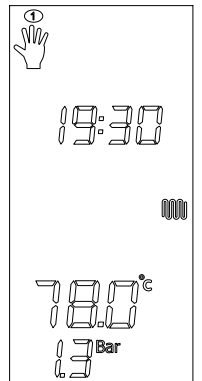

3. Press  to go back to the starting page, namely to quit the function.

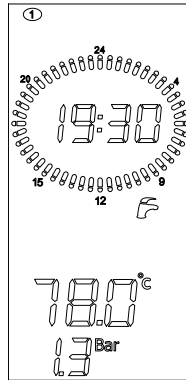

1.9 "Automatic" programme setting

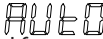
The selection of "automatic" mode, identified by symbol  , allows boiler to enable heating of both zones in "day temperature" or "night temperature", based on the programming envisaged for zone 1 and zone 2.

1. Press **PROG** twice to access the automatic programme setting mode.

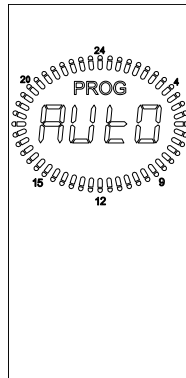

2. Press **OK** to confirm.
3. Press  to go back to the starting page, namely to quit the function.

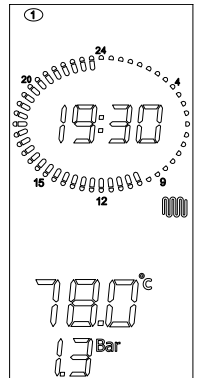

1.10 Heating and water heater programme mode

To access zone 1 heating programme displaying or editing, press  button twice.

1. The display shows zone 1 symbol flashing, sun or moon symbols, bars on or off, respectively, at 00:00. Clock lights display the programming connected to day 1 (Monday) and 00:00 bar is flashing.

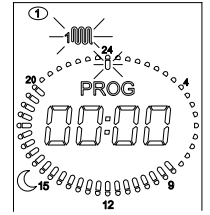

2. Press **OK** to access zone programming function. "PROG" wording starts flashing together with number 1 (Monday).

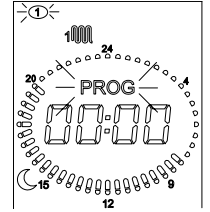



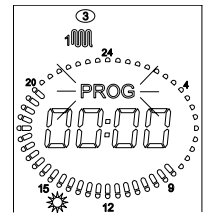

3. The required day can be selected by pressing **CH +/-** buttons.

4. Press **OK** to select the desired day.

5. Now you can associate the day/night level to the desired time of the day.





6. Whenever  /  button is pressed, the sun and moon symbols are alternatively activated (sun = day level; moon = night level).

7. At the same time, close to the current time (flashing bar) clock bar comes on if the  icon is on, and turns off the  icon is off.

8. Current time is indicated by both the clock and the flashing bar.

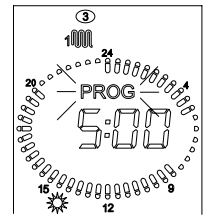
9. Press **CH +/-** buttons to move inside the different times of the day.



10. To program other days of the week or to program zone 2 and water heater, press .

11. You will go back to the starting page.

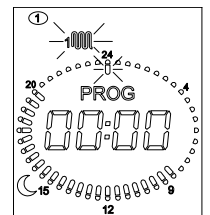



Whatever part of the programme can be quit by pressing the  button twice.

The procedure to program zone 2 and water heater, is very similar to the one followed to program zone 1.

Press the "prog" button to access, in sequence, to the following 4 programmes: manual; zone 1; zone 2; water heater.



If ambient probes are connected, the "day temperature" and the "night temperature" levels will acquire the temperature value, and heating will be active until the temperature measured by the ambient probe reaches the preset value for the different time slots.

When no ambient probe is connected, the two day/night levels will acquire the on and off values.

Heating is ON in the selected periods with the  icon, while it is OFF in the selected periods with the  icon.

In case of connection with "Open Therm" Remote Control, that zone shall not be managed by boiler boards, as it will be directly managed by the remote control and, as a consequence, zone programming will be inhibited.

1.11 Parameter display

Press  to scroll the different parameter values.
 You can quit this function at any time by simply pressing the  button.
 To find the meaning of all parameters, see *TSP parameters* on page 59.

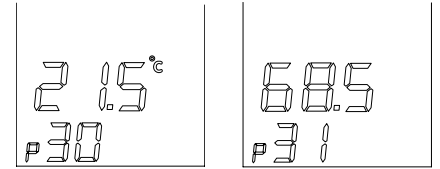



Par.	DESCRIPTION
P30 - TSP30	External temperature displaying (if an external probe is present).
P31	Flow temperature displaying.
P32	Calculated nominal flow temperature displaying. If no external probe is installed, the flow temperature manually set on boiler will be displayed. If an external probe is installed, the flow temperature boiler calculated through the thermoregulation curves will be displayed.
P33	Displaying of flow temperature set for zone 2 (V or Z versions).
P34	Displaying of flow temperature currently detected for zone 2 (V or Z versions)
P36	Displaying of flow temperature set for zone 3 (Z versions)
P37	Displaying of flow temperature currently detected for zone 3 (Z versions)
P43	Return temperature displaying.
P44	Displaying of water heater temperature, top part.
P45	Flue gas temperature displaying.
P46	Solar collector temperature display (if the SCS solar collector probe is installed).
P47	Displaying of solar water heater probe, low part.
P48	Displaying of solar valve temperature (if the solar valve probe is installed, standard in M, MV and MZ versions).
P49	Displaying of ambient probe 1 temperature (if ambient probe is connected).
P50	Displaying of ambient probe 2 temperature (if ambient probe is connected).

Tab. 1 Displayable parameters with info button

1.12 Failures that cannot be reset

The display shows the failure based on the corresponding error code (see *Troubleshooting* on page 90).
 Some failures can be reset through the  key, while some others are self-resettable (refer to the following paragraph).
 If failures cannot be reset but are of the self-resettable type, no key will be enabled and only the LCD backlighting will be on.
 As soon as the error cause is eliminated, the failure signal will disappear from the interface.
 The interface is enabled and after 15 seconds is disabled, unless a button is pressed.

1.13 Resume boiler function

The display shows the failure based on the corresponding error code (see *Troubleshooting* on page 90).
 Some failures can be reset through the  key, while some others are self-resettable.
 If shut-downs can be reset (E01, E02, E03, E40, E80, E86, E87), the reset key and the LCD backlighting will always be on.
 The only active key you can press is the  key.
 When the reset key is pressed and boiler is under the correct conditions, the error is reset. The failure signal will disappear from the interface.
 The interface is enabled and after 15 seconds is disabled, unless a button is pressed.

1.14 Boiler operation

1.14.1 Switching on



DANGER

It is presumed that the boiler has been installed by a qualified installer, it has been commissioned and is ready to operate correctly.

- Open the gas shut-off cock.
- Turn the master switch installed ahead of the boiler to ON.
- The display turns on and indicates the function currently active (see *Interpreting boiler status from display indications* on page 13).
- Select boiler operating mode by pressing  button on the touch-screen: OFF, SUMMER, WINTER, CH ONLY (see *Selecting the operating mode* on page 15).
- Set desired CH temperature (see *CH function* on page 22).
- Set desired DHW temperature (see *DHW function* on page 23).
- If one or more ambient probes or a thermostat are present, set the desired ambient temperature value and the weekly programming.



WARNING

Should the boiler be left inactive for a long time, particularly when boiler is propane-fired, ignition might be difficult.

Before starting the boiler switch on another gas powered device (e.g. kitchen range).

Beware that even by following this procedure, the boiler might still experience some starting difficulties and shut down once or twice. Press the RESET button to restore boiler operation.

1.14.2 CH function

Set desired heating water temperature via **CH +/-** buttons.



Heating temperature adjustment range depends on the selected operating range.:

- standard range: from 20°C to 78°C (pressing **CH +/-**);
- reduced range: from 20°C to 45°C (pressing **CH +/-**).

Operation range selection is to be implemented by a installer or an authorized Service Centre (see par. *Selecting the operating range in heating mode* on page 55).

During temperature setting, the CH  symbol on the screen flashes and the CH setting is displayed.

For models with double or triple outlet for high-temperature and low-temperature zones (V, MV, Z and MZ versions) the boiler operating range in CH mode must be set to standard range. The mixing valve on the low-temperature zone flow will adjust the flow to the correct temperature, based on the signal coming from the relevant zone.

When the central heating system requests heat from the boiler, the LCD displays the CH symbol fixed on  and the current heating flow water temperature. The burner symbol  only shows while the burner is operating. The waiting time between one boiler ignition and the following one, used to prevent boiler frequent turning on and off, ranges between 0 and 10 minutes (default value: 4 min.), and can be edited with the **P11** parameter.

Should water temperature in the system fall below set minimum value, between 20°C and 78°C (default value for standard range: 40°C, default value for reduced range: 20°C) to be edited with the **P27** parameter, the waiting time is reset and the boiler re-ignites (see par. *Selecting the operating range in heating mode* on page 55).

1.14.3 DHW function

The boiler is equipped with a 300-litre water heater with double coil, preset for connection to a solar system for the integration of domestic hot water production. This means that the production of domestic hot water can be guaranteed at the same time by the boiler burner and by the connection to a system of solar collectors (not supplied with the boiler).

1.14.3.1 DHW production through boiler burner

DHW production function through boiler burner may be enabled by the user in two ways:

- water heater programming (see *Heating and water heater programme mode*);
- "COMFORT" function enabling (see *Comfort function enable/disable*).



WARNING

Setting a water heater hour programming on the boiler (par. *Heating and water heater programme mode* on page 20), with "COMFORT" function on the boiler operates disregarding the set programming; if that is not so, the boiler operates according to the set programming.

Water heater heating, through the "COMFORT" function or programming, is carried out only if the boiler is in SUMMER or WINTER mode. If the boiler is in CH ONLY or OFF operating mode the water heater is not heated.

1.14.3.2 DHW production through solar plant

The domestic hot water production through solar plant is always enabled. The solar plant heats the water inside the water heater, according to the settings made on the touch-screen through the dedicated parameters (see par. *TSP parameters* on page 59). Parameter selection is to be carried out by an installer or an Authorised Service Centre.

The user can set the DHW temperature by using the manually-adjustable thermostatic mixing valve (A) located in the rear part of the boiler (see Fig. 2 Mixing valve position (rear view)).

The thermostatic mixing valve ensures a constant domestic hot water temperature, even if the water inside the water heater has reached very high temperatures.

Turning the knob anti-clockwise (+ position) increases the domestic hot water temperature, turning it clockwise (- position) decreases it.

To obtain an output temperature of approximately 50°C, completely close the valve (A) by turning the knob clockwise, then reopen it by turning it anti-clockwise by three and a half turns.



WARNING

Setting the manual mixing valve (A) to the clockwise or anticlockwise limit stop position is not recommended.

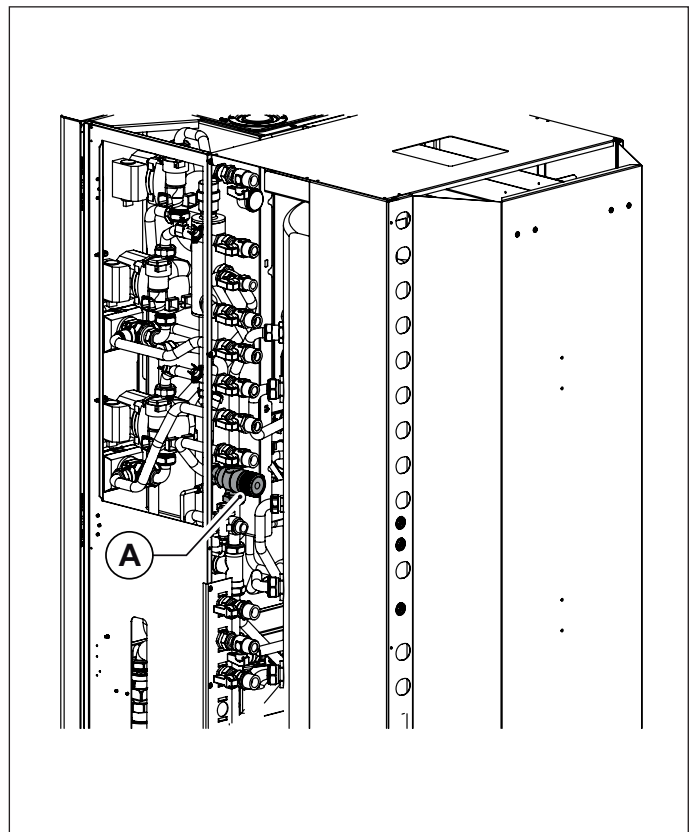

Fig. 2 Mixing valve position (rear view)

1.14.4 Freeze protection function

This boiler is fitted with a freeze protection system, which works when the following functions are activated: OFF/SUMMER/WINTER/CH ONLY.



DANGER

The freeze protection function only protects the boiler, not the whole heating system.

Ambient probes or a room thermostat must be used to provide freeze protection for the central heating system. Bear in mind, however, that they are disabled when the boiler is in OFF operating mode.

To protect the system, as well as the boiler, set the boiler to WINTER operating mode.

The central heating system can be effectively protected against icing by using specific anti-freeze products that are suitable for multi-metal systems.



WARNING

Do not use anti-freeze products for car engines, and check the effectiveness of the product used over time.

In case burner cannot be ignited due to the lack of gas, the freeze protection functions are anyway enabled through the circulation pumps.

1.14.4.1 Ambient probe freeze protection function

If the ambient probes detect a temperature below 5°C, a heating request to heat the probe-controlled room is launched.

The heating function ends when the probe ambient temperature reading reaches +6°C.

1.14.4.2 Flow freeze protection function

When the heating water temperature sensor detects a water temperature of +5 °C, the boiler switches on and stays on at its minimum heat output until the temperature reaches +30 °C or 15 minutes have elapsed.

The pump continues to operate even if the boiler shuts down.

1.14.4.3 Water heater freeze protection function

When water heater temperature sensor detects a water temperature of +5 °C, the boiler switches on and stays on at its minimum heating output until the temperature of the water in the heater reaches +10 °C or 15 minutes have elapsed.

The pump continues to operate even if the boiler shuts down.

During the water heater anti-freeze operation the temperature detected by the flow probe is constantly checked, and in case it reaches +60°C the burner is switched off.

The burner is switched on again if the operation request in anti-freeze mode is still present and the flow temperature is below +60°C.

1.14.4.4 Solar collector freeze protection function

Solar collector freeze protection function is enabled by setting parameter **P24** = 1.

With this function, solar pump is activated as soon as solar collector probe detects a temperature of 4° C.

1.14.5 Anti-seize function

If the boiler remains inactive and connected to the power mains, the circulation pump and the deviating valve will be shortly enabled every 24 hours so as to avoid any shut-down.

The same applies to the relay which can be freely programmed whenever this latter is used to power a recirculation pump or a deviating valve, to the solar plant circulation pump and to the deviating valve for thermal discharge (M version).

On models with high- and low-temperature outlet (V, MV, Z, MZ versions) the high- and low-temperature zone pumps and the mixing valves are equipped with an anti-shutdown function.

1.14.6 Water heater anti-legionella function

Every 15 days the anti-legionella function is enabled. It gets the water heater temperature to 65 °C for 30 minutes, regardless of any other setting, in order to prevent or remove possible proliferation of bacteria inside the water heater

1.14.7 Collector heat transfer function

This function prevents that solar collectors in stagnation state are exposed to high thermal stresses.

With the boiler in SUMMER, WINTER or CH ONLY mode, if the temperature read by solar collector probe is between 110°C and 115°C (editable with parameter **P22**) and the temperature measured by the solar water heater probe is below 93 °C, solar pump is enabled to fill water heater. Solar pump operation is disabled as soon as solar collector temperature goes below 108 °C or solar water heater probe detects a temperature above 95°C.

1.14.8 Thermal discharge function (M versions only)

With boiler in SUMMER, WINTER or CH ONLY mode and parameter **P76**=1, if the temperature measured by the solar collector probe is over 110 °C and at the same time the temperature measured by the boiler water heater probe is over 95 °C, the deviating valve for thermal discharge is switched to the thermal discharge position, and the solar pump is activated. The function stops when the collector temperature drops below 108 °C. If the boiler water heater temperature probe is faulty, the function is not activated. Moreover, thermal discharge is disabled when the collector temperature is over 120 °C.

1.14.9 Water heater cooling function

This function consists in cooling water heater down to the set-point value set by the user (parameter **P19**) by transferring excess heat from the water heater to the solar collector.

With the boiler in SUMMER, WINTER or CH ONLY mode, if water heater temperature is 2°C higher than set-point temperature (parameter **P19**) and collector probe temperature is 6°C lower than solar water heater probe temperature (editable with parameter **P20**), solar pump is enabled to cool water heater. Function is interrupted as soon as water heater temperature reaches the set-point value set by the user, or when solar collector probe temperature is 3°C lower than solar water heater probe temperature (editable with parameter **P21**). Function can be disabled with parameter **P26** (**P26** = 1 enabled; **P26** = 0 disabled).

1.14.10 Solar mode operation and failure signal

When solar pump is active, symbol  appears on the display. If solar collector probe or solar water heater probe are faulty, error codes **E24** and **E28** will be displayed, respectively. Solar pump will be turned off.

1.14.11 Operation with external probe (optional)

Boiler can be connected to a probe measuring the external temperature (optional - not compulsory, supplied by the manufacturer).

Once the external temperature value is known, the boiler will automatically adjust the heating water temperature: increasing it as the external temperature decreases and decreasing it as the external temperature increases. This will both improve room comfort and reduce fuel consumption. The maximum temperature is respected all the same.

This boiler operating mode is called "sliding temperature operation".

Heating water temperature varies based on a programme written inside boiler electronic microprocessor.

When working with an external probe, the **CH +/-** buttons are no longer used to set heating water temperature, but to edit fictitious ambient temperature, namely the desired theoretical temperature.

During temperature setting, the fictitious ambient temperature  symbol flashes on the display and the value being set is shown.

For optimal curve adjustment, a position close to +20 °C is recommended.

For further details on "cruising temperature operation", refer to paragraph *Installation of the (optional) external probe and sliding temperature operation* on page 57.



WARNING

Only original external temperature probes supplied by the manufacturer must be used.

The use of non-original external probes, not supplied by the manufacturer, may affect the operation of the external probe itself and of the boiler.

1.14.12 Operation with (optional) remote control

The boiler can also be connected to a Remote Control (optional - not compulsory, supplied by the manufacturer) so as to manage several boiler parameters, such as:

- boiler status selection.
- ambient temperature selection.
- CH system water temperature selection.
- DHW temperature selection.
- CH system or heater activation times programming.
- boiler diagnostics display.
- boiler reset and other parameters.

To connect the Remote Control, see *Installation and operation with Open Therm Remote Control (optional)* on page 56.



WARNING

Only use original Remote Control Units supplied by the manufacturer.

The use of non-original remote controls, not supplied by the manufacturer, may affect Remote Control and boiler operation.

1.15 Boiler shut-down

The boiler shuts down automatically if a malfunction occurs (see *Interpreting boiler status from display indications* on page 13).

To determine the possible causes of malfunction, see *Troubleshooting* on page 90.

Below is a list of shut-down types and the procedure to follow in each case.

1.15.1 Burner shut-down

Fault code **E01** is displayed flashing on the display in the event of burner shut-down due to missing flame.

If this happens, proceed as follows:

- check that the gas cock is open and light a kitchen gas ring for example to check the gas supply;
- once having checked if the fuel is available, press the  button to restore burner operation: if, after two starting attempts, the boiler still fails to start and enters the shut-down mode again, contact a service centre or qualified personnel for maintenance.



WARNING

If the burner shuts down frequently, there is a recurring malfunction, so contact a service centre or a qualified service engineer.

1.15.2 Shut-down due to incorrect air/flue gas system draught

The boiler is equipped with a safety device for flue gas exhaustion check.

Should an air/flue gas system malfunction occur, the control device will shut-down the boiler by interrupting the gas supply to the boiler and the LCD will display the **E03** code.

In this case, contact a Service Centre or a qualified service engineer to carry out the maintenance.

1.15.3 Shut-down due to low water pressure

If "shutdown due to insufficient pressure in system" error **E04** starts flashing (indicating safety water pressure switch triggering), fill the system by opening the filler cock as shown in Fig. 3 Filler cock. **E04** error is displayed when system pressure drops below 0.4 bar and error will be automatically reset as soon as system pressure reaches 1.0 bar. Water pressure must be 1-1.3 bars while the boiler is cold.

In order to restore water pressure, proceed as follows:

- turn the filler cock Fig. 3 Filler cock anticlockwise to allow water to enter the boiler;
- keep the cock open until the control panel shows a value of 1÷1.3 bar;
- turn cock clockwise to close it.

If the boiler still fails to operate, contact a service centre or a qualified service engineer.



DANGER

Make sure you close the cock carefully after filling. If you do not, when the pressure increases, error E09 may be displayed and the heating system safety valve may activate and discharge water.

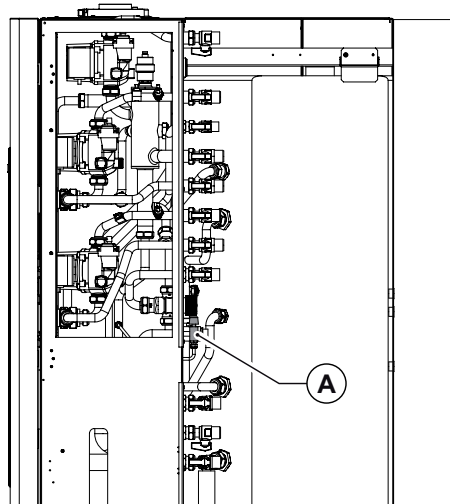

Fig. 3 Filler cock

1.15.4 Shut-down for fan malfunction

The fan operation is constantly monitored and in case of malfunction the burner goes off; the code **E40** flashes on the display. This mode is maintained until the fan recovers normal working parameters.
If the boiler does not start and remains in this mode, contact a service centre or a qualified service engineer.

1.15.5 Alarm due to temperature probe malfunction

The following fault codes are shown on the display in the event of burner shut-down due to a temperature probe fault:

- **E05** for the CH flow probe. In this case the boiler ignition is disabled.
- **E12** for boiler water heater probe top part. In this case the boiler does not carry out the DHW function.
- **E15** for the return probe. In this case the boiler does not work.
- **E24** for the solar collector probe. In this case, the water heater CANNOT be heated by the solar collectors. The CH and DHW production functions operate normally.
- **E27** for the solar valve probe (M, MV and MZ versions). In this case the heat transfer function is disabled.
- **E28** for the solar water heater probe, low part. In this case, the water heater CANNOT be heated by the solar collectors.
- **E36** for CH flow probe in one of the installed zones (V, Z, MV and MZ versions). In this case boiler ignition is disabled only for the zone affected by the fault. All other zones operate correctly.



WARNING

In any case, contact a service centre or qualified personnel for maintenance.

1.15.6 Alarm due to (optional) Remote Control connection malfunction

The boiler recognises whether or not there is a Remote Control (optional, not compulsory).

If the boiler does not receive information from the Remote Control after the Remote Control itself is connected, the boiler attempts to re-establish communication for 60 seconds, after which the fault code **E31** is shown on the remote control display.

The boiler will continue to operate according to the settings on the touch screen and ignore the Remote Control settings.



WARNING

Contact a service centre or a qualified service engineer to carry out the maintenance.

The remote control can indicate faults or shutdown conditions and can also restore boiler operation after shutdown up to a maximum of 3 times in a 24 hour period.

If the maximum number of attempts is reached, fault code **E99** is shown on the boiler display.

To reset error **E99**, disconnect and re-connect again boiler from/to power mains.

1.16 Maintenance



WARNING

The boiler must be serviced periodically as indicated in the relevant section of this manual. Appropriate boiler maintenance ensures efficient operation, environment preservation, and safety for people, animals and objects. Boilers must be maintained by qualified personnel only, under the requirements set forth by the prevailing rules.



WARNING

The user may only clean the external casing of the boiler, employing common household products. Do not use water!

1.17 Notes for the user



WARNING

The user may only access parts of the boiler that can be reached without using special equipment or tools. The user is not authorised to remove the boiler casing or to operate on any internal parts. No one, including qualified personnel, is authorised to modify the boiler. The manufacturer shall not be held responsible in case of damage to people, animals, or property due to failure to follow the above mentioned instructions. If the boiler remains inactive and the power supply is switched off for a long time, it may be necessary to reset the pump. This involves removing the casing and accessing internal parts, so it must only be carried out by suitably qualified personnel. Pump failure can be avoided by adding to the water filming additives suitable for multi-metal systems.

2. Technical features and dimensions

2.1 Technical features

This boiler is equipped with a built-in fully pre-mixed gas burner, a condensing heat exchanger, a twin-coil 300L water heater and hydraulic and electronic systems for connection to a solar plant.

The following models are available:

- **KRBS** Condensing boiler with sealed chamber and forced draught, supplying CH water and domestic hot water.
- **KRBS M** Condensing boiler with sealed chamber and forced draught, supplying CH water and domestic hot water. Version with solar three-way valve for thermal discharge.
- **KRBS V** Condensing boiler with sealed chamber and forced draught, supplying CH water and domestic hot water. Version preset for connection to a high-temperature and a low-temperature zone.
- **KRBS MV** Condensing boiler with sealed chamber and forced draught, supplying CH water and domestic hot water. Version with solar three-way valve for thermal discharge, preset for connection to a high-temperature zone and a low-temperature zone.
- **KRBS Z** Condensing boiler with sealed chamber and forced draught, supplying CH water and domestic hot water. Version preset for connection to a high-temperature zone and two low-temperature zones.
- **KRBS MZ** Condensing boiler with sealed chamber and forced draught, supplying CH water and domestic hot water. Version with solar three-way valve for thermal discharge, preset for connection to a high-temperature zone and two low-temperature zones.

The following power rates are available:

- **12** with heat output of 12.0 kW
- **24** with heat output of 23.7 kW
- **28** with heat output of 26.4 kW
- **32** with heat output of 30.4 kW

The boilers meet local applicable Directives enforced in the country of destination, which are stated on their rating plate. Installation in any other country may be a source of danger for people, animals and property.

The key technical features of the boilers are listed below.

2.1.1 Manufacturing characteristics

- IPX5D electrically protected control panel.
- Integrated, modulating electronic safety board.
- Solar plant electronic control board.
- Electronic start-up with igniter and ionisation flame detection.
- Stainless steel, fully pre-mixed burner.
- Mono-thermal, high efficiency, composite and stainless steel heat exchanger with air purging device.
- Twin shutter modulating gas valve with constant air/gas ratio.
- Modulating, electronically managed combustion fan.
- Modulating CH circulation pump with built-in air purging device.
- Heating circuit pressure sensor.
- Hydraulic separator, mixing valves and circulation pumps for high- and low-temperature outlets (V, MV, Z and MZ versions).
- Circulation pump for solar plant.
- Solar plant hydraulic control unit.
- Heating flow water temperature probe (double).
- Temperature probe for water heater (bottom and top parts).
- Temperature probe for solar collector.
- Temperature probe for solar valve (M, MV and MZ versions).
- Safety limit thermostat on low-temperature flow zones.
- Double safety probe on CH flow.
- Flue gas thermostat on discharge tower
- Flue gas probe on primary heat exchanger.
- Integrated, automatic by-pass.
- Heating expansion vessel - 10 litres.
- Domestic hot water expansion vessel - 12 litres.
- Solar expansion vessel - 18 litres.
- Central heating system loading and draining cocks.
- Water heater discharge cock.
- 3-bar safety valve for CH circuit.
- 6-bar safety valve for DHW circuit.
- 6-bar safety valve for solar circuit.
- Motorised deviating valve for water heater heating.
- Motorised deviating valve for thermal discharge (M, MV and MZ versions).

2.1.2 User interface

- Touch interface with built-in LCD to display and control boiler operating condition: OFF, WINTER, SUMMER and CH ONLY;
- System water temperature regulator: 20/78 °C (standard range) – 20/45 °C (reduced range);
- DHW temperature regulator on the control panel: 35/65 °C;
- Manual mixing valve for domestic hot water temperature setting.

2.1.3 Operating features

- CH electronic flame modulation with timer-controlled rising ramp (60 seconds, adjustable).
- Electronic flame modulation in water heater DHW mode.
- DHW function priority.
- Flow freeze protection function: ON 5°C; OFF 30°C or after 15 minutes of operation if CH temperature > 5 °C.
- Water heater freeze protection function: ON 5°C; OFF 10 °C or after 15 minutes of operation if DHW temperature > 5 °C.
- Anti-legionella function (every 15 days the boiler temperature is brought to 65 °C for 30').
- Timer-controlled flue cleaning function: 15 minutes.
- Ignition flame propagation function.
- Possibility to select the heating range: standard or reduced.
- CH Maximum heat input parameter adjustment.
- Ignition heat input adjustment parameter.
- CH thermostat timer: 240 seconds (adjustable).
- Heating pump post-circulation function in CH, freeze protection and flue cleaning modes: 30 seconds (adjustable).
- Water heater DHW post-circulation function: 30 seconds.
- Post-circulation function for heating temperature > 78 °C: 30 seconds.
- Post-ventilation function: at the end of each operation request, the fan continues to operate for 10 seconds.
- Safety post-ventilation function: with flow temperature > 95 °C, the fan is activated until the flow temperature drops below 90 °C;
- Heating pump and deviating valve anti-shutdown function: 30 seconds of operation every 24 hours with boiler not in use.
- Solar plant pump anti-shutdown function (10 seconds of operation every 24 hours not in use).
- Solar valve anti-shutdown function (M, MV and MZ versions; 10 seconds of operation every 24 hours not in use).
- Mixing valves and zone pumps anti-shutdown function (V, Z, MV and MZ versions; 10 seconds of operation every 24 hours not in use).
- Anti-water hammer function: can be set from 0 to 10 seconds through parameter P15.
- High- and low-temperature zone heating system supply (V, MV, Z and MZ versions).
- Solar plant thermal discharge function (M, MV and MZ functions).
- Solar collector heat transfer function.
- Water heater cooling function.
- Ready for chronothermostat function on the boiler, in combination with two ambient probes (optional, supplied by manufacturer).
- Ready for operation with an OpenTherm remote control (optional, supplied by the manufacturer).
- Ready for operation with external temperature probe (standard on V, Z, MV and MZ versions, optional on all other versions).
- Presetting for connection to a domestic hot water recirculation system, with suitable kit (optional, supplied by the manufacturer).

2.2 Dimensions

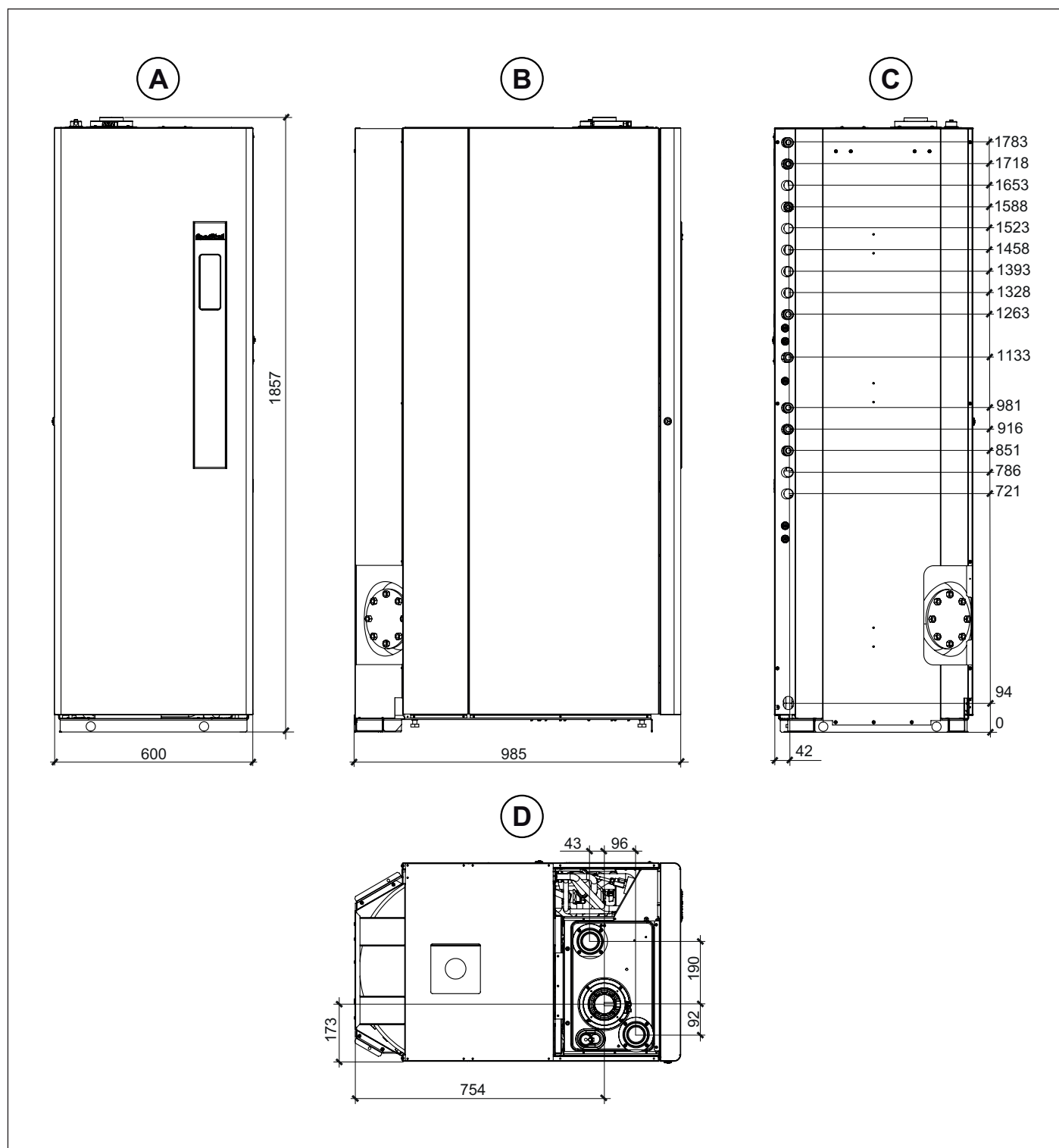

Fig. 4 Dimensions

- A Front view
- B LH view
- C Rear view
- D View from top

2.3 Boiler layouts

MADEIRA SOLAR KRBS and MADEIRA SOLAR KRBS M

1. CH system flow 3/4"
2. CH return 3/4"
3. Gas 1/2"
4. DHW outlet (3/4")
5. Cold water inlet 1/2"
6. Solar return 3/4"
7. Recirculation (optional) 3/4"
8. Solar flow 3/4"
9. Thermal discharge flow 3/4" M versions
10. Thermal discharge return 3/4" - M versions
11. Condensate drain

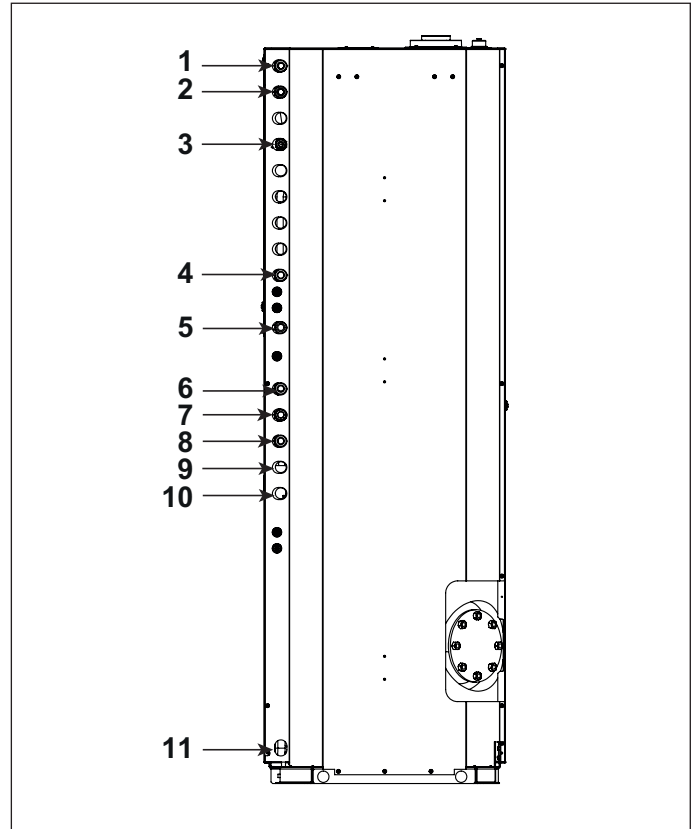

Fig. 5 Hydraulic diagram

MADEIRA SOLAR KRBS V and MADEIRA SOLAR KRBS MV

1. High-temperature CH flow 3/4"
2. Low-temperature CH flow 3/4"
3. Gas 1/2"
4. High-temperature CH return 3/4"
5. Low-temperature CH return 3/4"
6. DHW outlet (3/4")
7. Cold water inlet 1/2"
8. Solar return 3/4"
9. Recirculation (optional) 3/4"
10. Solar flow 3/4"
11. Thermal discharge flow 3/4" MV versions
12. Thermal discharge return 3/4" - MV versions
13. Condensate drain

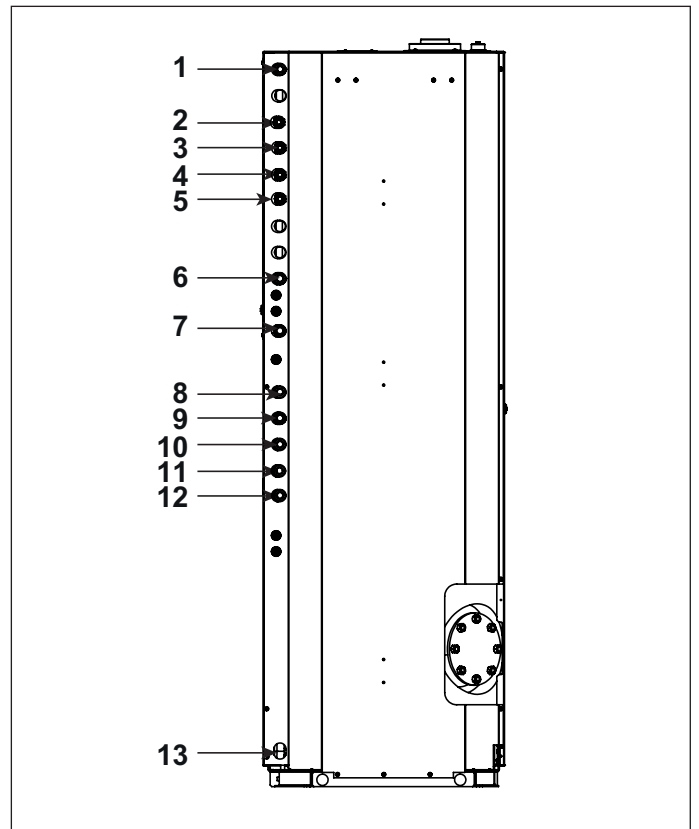

Fig. 6 Hydraulic diagram

MADEIRA SOLAR KRBS Z and MADEIRA SOLAR KRBS MZ

1. High-temperature CH flow zone 1 - 3/4"
2. Low-temperature CH flow zone 2 - 3/4"
3. Gas 1/2"
4. High-temperature CH return zone 1 - 3/4"
5. Low-temperature CH return zone 2 - 3/4"
6. Low-temperature CH flow zone 3 - 3/4"
7. Low-temperature CH return zone 3 - 3/4"
8. DHW outlet (3/4")
9. Cold water inlet 1/2"
10. Solar return 3/4"
11. Recirculation (optional) 3/4"
12. Solar flow 3/4"
13. Thermal discharge flow 3/4" MZ versions
14. Thermal discharge return 3/4" - MZ versions
15. Condensate drain

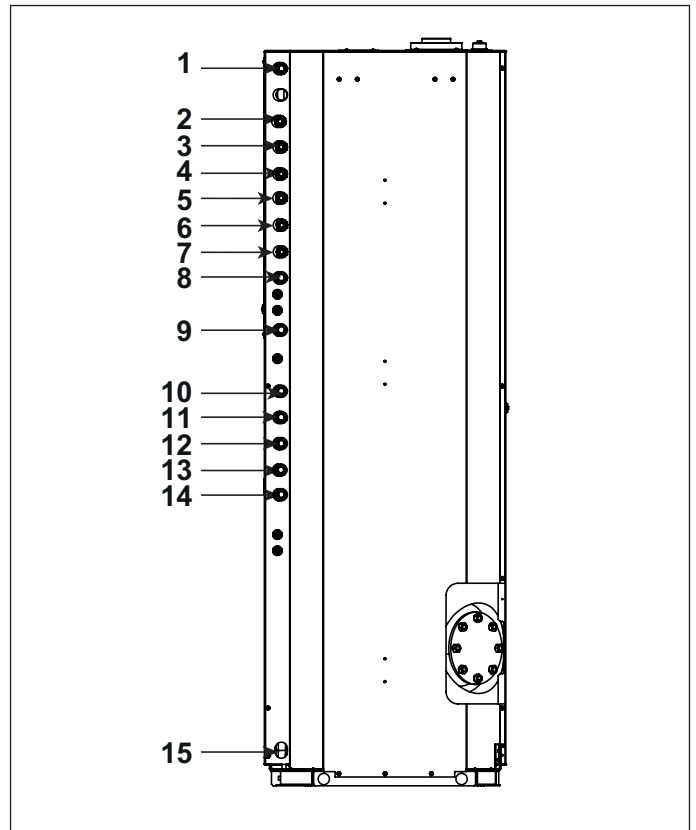

Fig. 7 Hydraulic diagram

2.4 Key components

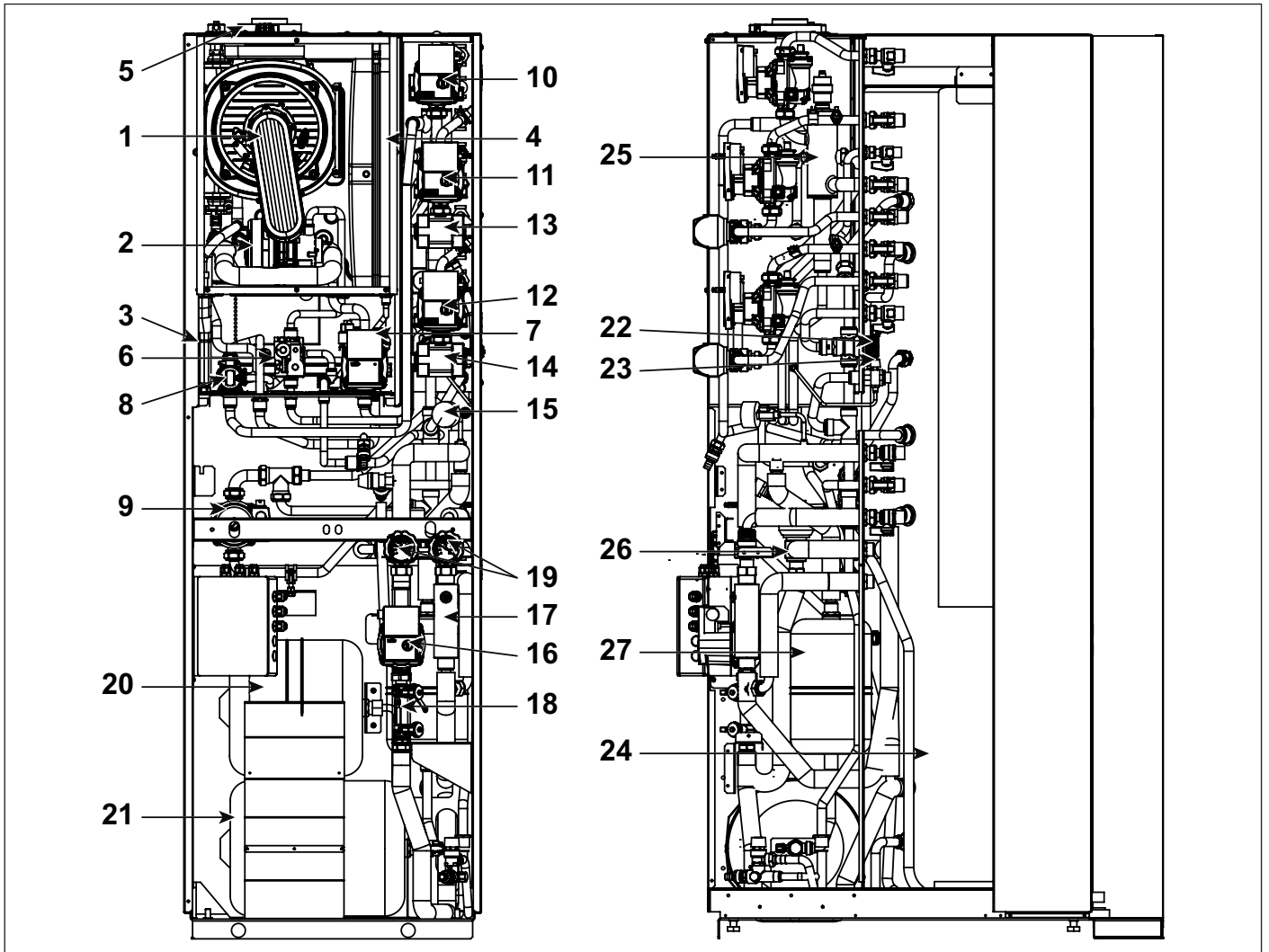

Fig. 8 Key components

- | | |
|---|---|
| 1. Pre-mixed burner | 16. Solar system pump |
| 2. Modulating fan | 17. Solar system air purging device |
| 3. Gas valve | 18. Solar plant flowmeter with filler cock and discharge cock |
| 4. CH expansion vessel | 19. Ball valves with thermometers on solar plant flow and return |
| 5. Flue gas discharge tower | 20. DHW expansion vessel |
| 6. Condensate trap | 21. Solar expansion vessel |
| 7. Modulating heating pump | 22. DHW temperature mixing valve |
| 8. Three-way valve | 23. Heating system filler cock |
| 9. DHW recirculation pump (optional) | 24. 300-litre solar water heater |
| 10. Zone 1 high-temperature pump (V, MV, Z, MZ versions) | 25. Hydraulic separator |
| 11. Zone 2 low-temperature pump (V, MV, Z, MZ versions) | 26. Deviating valve for thermal discharge (M, MV and MZ versions) |
| 12. Zone 3 low-temperature pump (Z, MZ versions) | 27. Additional solar vessel |
| 13. Zone 2 low-temperature mixing valve (V, MV, Z, MZ versions) | |
| 14. Zone 3 low-temperature mixing valve (Z, MZ versions) | |
| 15. Solar system pressure gauge | |

2.5 Boiler layouts

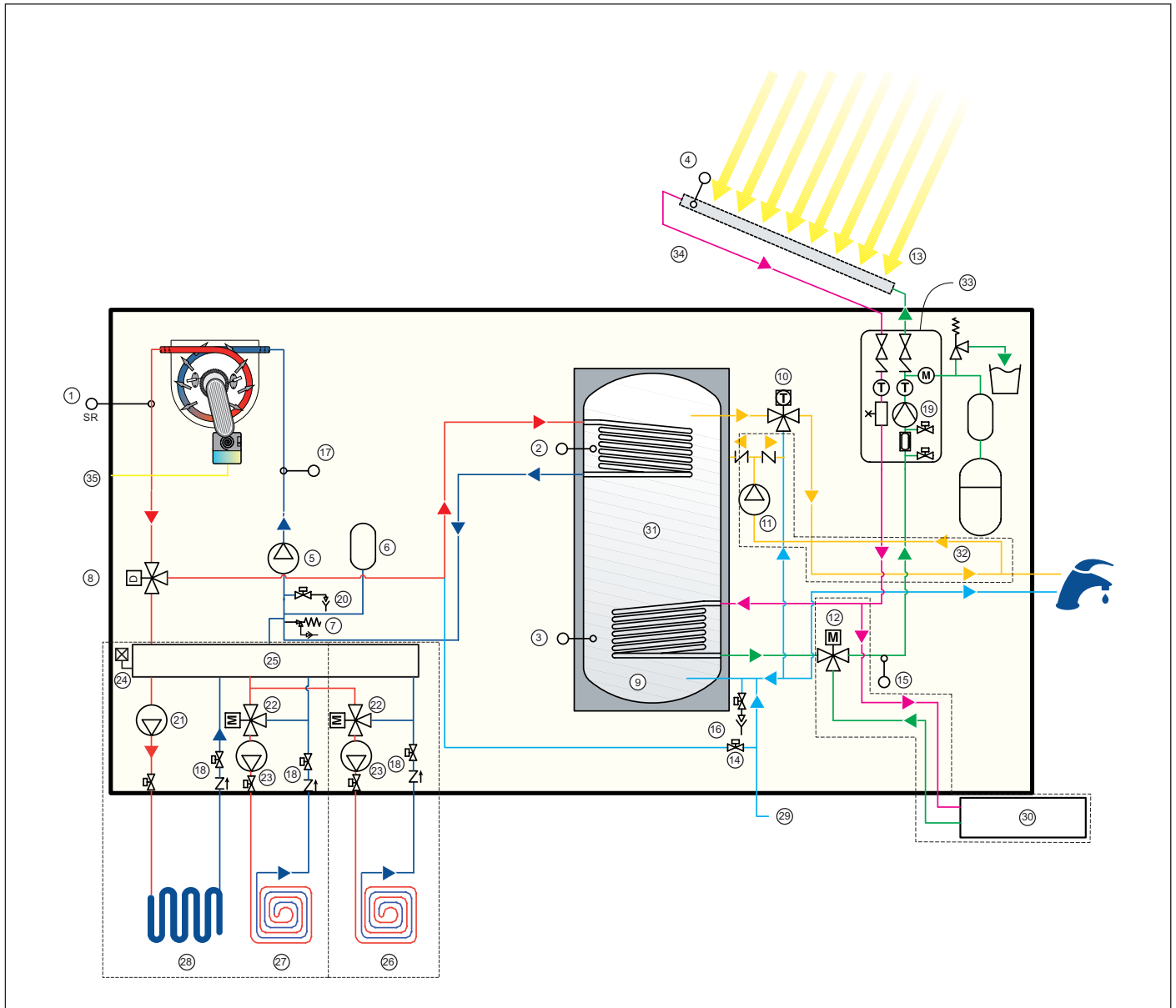

Fig. 9 Boiler operation diagram

Key elements

- | | |
|--|--|
| 1. CH flow probe | 18. Cock with non-return valve |
| 2. Boiler water heater probe (top part) | 19. Solar circulation pump |
| 3. Solar water heater probe (low part) | 20. Heating circuit discharge cock |
| 4. Solar collector probe | 21. High-temperature zone circulation pump (V, MV, Z, MZ versions) |
| 5. Modulating CH pump | 22. Motorised 3-way mixing valve |
| 6. CH expansion vessel 10 l. | 23. Low-temperature zone circulation pump (V, MV, Z, MZ versions) |
| 7. 3-bar safety valve | 24. Automatic gas purging device |
| 8. Motorised 3-way deviating heating valve | 25. Separator |
| 9. 300 litre water heater | 26. Low temperature 3 (Z versions) |
| 10. 3-way thermostatic manual mixing valve | 27. Low temperature 2 (V versions) |
| 11. Recirculation pump (optional) | 28. High temperature 1 (V versions) |
| 12. Motorised 3-way deviating valve for thermal discharge (M versions) | 29. Domestic water system |
| 13. Solar panel (optional) | 30. Secondary user (M versions) |
| 14. Heating circuit filler cock | 31. Water heater |
| 15. Solar valve probe (M versions) | 32. Recirculation (optional) |
| 16. Water heater drain cock | 33. Solar unit |
| 17. CH return probe | 34. Solar panel |
| | 35. Gas |

2.6 Operating data

Burner pressures reported in the following page must be verified after the boiler has been operating for 3 minutes.

Gas category: II2H3P

Fuel	Gas mains pressure [mbar]	Nozzle [mm]	Diaphragm diameter [mm]	Flue CO2 value [%]
Natural gas G20	20	3.05	-	9.0 ÷ 9.3
Propane Gas G31	37	2.50	-	10.0 ÷ 10.3

Tab. 2 Adjustment specifications 12 kW

Fuel	Gas mains pressure [mbar]	Nozzle [mm]	Diaphragm diameter [mm]	Flue CO2 value [%]
Natural gas G20	20	3.70	-	9.0 ÷ 9.3
Propane Gas G31	37	3.00	-	10.0 ÷ 10.0

Tab. 3 Adjustment specifications 24 kW

Fuel	Gas mains pressure [mbar]	Nozzle [mm]	Diaphragm diameter [mm]	Flue CO2 value [%]
Natural gas G20	20	4.00	-	9.0 ÷ 9.3
Propane Gas G31	37	3.30	-	10.0 ÷ 10.3

Tab. 4 Adjustment specifications 28 kW

Fuel	Gas mains pressure [mbar]	Nozzle [mm]	Diaphragm diameter [mm]	Flue CO2 value [%]
Natural gas G20	20	4.45	-	9.0 ÷ 9.3
Propane Gas G31	37	3.55	7.2	10.0 ÷ 10.0

Tab. 5 Adjustment specifications 32 kW

2.7 General characteristics

Description	um	KRBS 12	KRBS 24	KRBS 28	KRBS 32	
CH nominal heat input	kW	12.0	23.7	26.4	30.4	
Minimum heat input	kW	2.0	3.0	3.3	4.2	
Maximum heat output (80-60°C) - CH	kW	11.6	22.9	25.4	29.4	
Minimum heat output (80-60°C) - CH	kW	1.8	2.7	3.0	3.9	
Maximum heat output (50-30°C) - CH	kW	12.6	24.9	27.9	32.3	
Minimum heat output (50-30°C) - CH	kW	2.1	3.22	3.58	4.4	
Minimum CH system pressure	bar	0.5	0.5	0.5	0.5	
Maximum CH system pressure	bar	3.0	3.0	3.0	3.0	
DHW maximum heat input	kW	18.0	27.3	30.4	34.5	
DHW minimum heat input	kW	2.0	3.0	3.3	4.2	
DHW circuit min. pressure	bar	0.5	0.5	0.5	0.5	
DHW circuit max. pressure	bar	6.0	6.0	6.0	6.0	
DHW specific flow rate ($\Delta T=25K$)	l/min	28.3	28.3	30.4	31.6	
DHW specific flow rate ($\Delta T=30K$)	l/min	23.6	23.6	25.3	26.3	
Qualification of domestic hot water - EN 13203-1	-	★★★	★★★	★★★	★★★	
Draw capacity for 10 min. - EN 13203-1	l/min	17.6	22.0	22.4	22.4	
Electric power supply – voltage / frequency	V - Hz	230 -50	230 -50	230 -50	230 -50	
Power mains supply fuse	A	3.15	3.15	3.15	3.15	
Maximum power consumption	KRBS	W	95	103	106	114
	KRBS V	W	181	189	191	199
	KRBS Z	W	230	238	240	199
Pump absorption	KRBS	W	46	46	46	46
	KRBS V	W	125	125	125	125
	KRBS Z	W	170	170	170	170
Electric protection rating	IP	X5D	X5D	X5D	X5D	
Natural gas consumption at maximum CH output (Value referred to 15 °C - 1013 mbar)	cu. m/h	1.27	2.51	2.79	3.22	
Propane gas consumption at maximum CH output	kg/h	0.93	1.84	2.05	2.36	
Maximum CH working temperature	°C	83	83	83	83	
Maximum DHW working temperature	°C	65	65	65	65	
Heating expansion vessel total capacity	l	10	10	10	10	
DHW expansion vessel total capacity	l	12	12	12	12	
Solar total expansion vessel capacity (+ additional vessel)	l	18+5	18+5	18+5	18+5	
Maximum recommended system capacity (Maximum water temperature 83°C, expansion vessel pressure 1 bar)	l	200	200	200	200	

Tab. 6 General specifications

For M versions (KRBS M, MV and MZ) add 1 W to power indication of the corresponding versions (KRBS, V and Z).

Description	um	Max. output	Min. output	30% load
Casing heat loss with burner on	%	0.26	7.78	-
Casing heat loss with burner off	%	0.55		
Flue system heat loss with burner on	%	2.64	1.92	-
Flue system mass capacity	g/s	8.25	0.89	-
Flue temp. – air temp.	°C	57.9	34.5	-
Heat output efficiency rating (60/80°C)	%	97.1	90.3	-
Heat output efficiency rating (30/50°C)	%	105.1	105	-
30% heat output efficiency rating	%	-	-	106.0
NOx emission class	-	5		

Tab. 7 Combustion specifications 12 kW

Description	um	Max. output	Min. output	30% load
Casing heat loss with burner on	%	0.97	6.49	-
Casing heat loss with burner off	%	0.28		
Flue system heat loss with burner on	%	2.62	2.09	-
Flue system mass capacity	g/s	12.43	1.33	-
Flue temp. – air temp.	°C	61.0	33.0	-
Heat output efficiency rating (60/80°C)	%	96.7	91.4	-
Heat output efficiency rating (30/50°C)	%	105.1	104.9	-
30% heat output efficiency rating	%	-	-	106.5
NOx emission class	-	5		

Tab. 8 Combustion specifications 24 kW

Description	um	Max. output	Min. output	30% load
Casing heat loss with burner on	%	1.4	5.7	-
Casing heat loss with burner off	%	0.25		
Flue system heat loss with burner on	%	2.4	2.0	-
Flue system mass capacity	g/s	13.93	1.47	-
Flue temp. – air temp.	°C	60.0	45.0	-
Heat output efficiency rating (60/80°C)	%	96.4	92.3	-
Heat output efficiency rating (30/50°C)	%	105.5	104.5	-
30% heat output efficiency rating	%	-	-	107.0
NOx emission class	-	5		

Tab. 9 Combustion specifications 28 kW

Description	um	Max. output	Min. output	30% load
Casing heat loss with burner on	%	0.99	5.06	-
Casing heat loss with burner off	%	0.22		
Flue system heat loss with burner on	%	2.61	2.04	-
Flue system mass capacity	g/s	15.81	1.87	-
Flue temp. – air temp.	°C	60.0	40.5	-
Heat output efficiency rating (60/80°C)	%	96.8	92.9	-
Heat output efficiency rating (30/50°C)	%	106.2	104.8	-
30% heat output efficiency rating	%	-	-	108.3
NOx emission class	-	5		

Tab. 10 Combustion specifications 32 kW

2.8 ERP and Labelling data

Model(s): MADEIRA SOLAR KRBS 12	
Condensing boiler: yes	
Low-temperature (***) boiler: yes	
B1 boiler: no	
Cogeneration space heater: no	If yes, equipped with a supplementary heater: -
Combination heater: yes	

Item	Symbol	Value	Unit	Item	Symbol	Value	Unit					
Rated heat output	P_{rated}	12	kW	Seasonal space heating energy efficiency	η_s	90	%					
For boiler space heaters and boiler combination heaters: Useful heat output				For boiler space heaters and boiler combination heaters: Useful efficiency								
At rated heat output and high-temperature regime (*)	P_4	11,7	kW	At rated heat output and high-temperature regime (*)	η_4	86,2	%					
At 30 % of rated heat output and low-temperature regime (**)	P_1	3,8	kW	At 30 % of rated heat output and low-temperature regime (**)	η_1	95,5	%					
Auxiliary electricity consumption				Other items								
At full load	$e_{l,max}$	KRBS	0,020	kW	Standby heat loss	P_{stby}	0,064	kW				
		KRBS-M	0,021									
		KRBS-V - KRBS-MV	0,022									
		KRBS-Z - KRBS-MZ	0,023									
At part load	$e_{l,min}$	KRBS	0,013	kW	Ignition burner power consumption	P_{ign}	0,000	kW				
		KRBS-M	0,015									
		KRBS-V - KRBS-MV	0,016									
		KRBS-Z - KRBS-MZ	0,017									
In standby mode	P_{SB}	KRBS	0,003	kW	Annual energy consumption	Q_{HE}	21	GJ				
		KRBS-M	0,004									
		KRBS-V - KRBS-MV	0,005									
		KRBS-Z - KRBS-MZ	0,006									
For combination heaters:				Water heating energy efficiency	η_{wh}	KRBS: 91 KRBS-M-V- MV-Z-MZ: 90	%					
Declared load profile	XXL											
Daily electricity consumption	Q_{elec}	KRBS	0,198					kWh	Daily fuel consumption	Q_{fuel}	33,480	kWh
		KRBS-M	0,227									
		KRBS-V - KRBS-MV	0,251									
		KRBS-Z - KRBS-MZ	0,275									
Annual electricity consumption	AEC	KRBS	43	kWh	Annual fuel consumption	AFC	26	GJ				
		KRBS-M	49									
		KRBS-V - KRBS-MV	55									
		KRBS-Z - KRBS-MZ	60									

Contact details: FONDITAL S.p.A. - Via Cerreto, 40 I-25079 VOBARNO (Brescia) Italia - Italy

(*) High-temperature regime means 60 °C return temperature at heater inlet and 80 °C feed temperature at heater outlet.

(**) Low temperature means for condensing boilers 30 °C, for low-temperature boilers 37 °C and for other heaters 50 °C return temperature (at heater inlet).

Seasonal space heating energy efficiency class	A
Water heating energy efficiency class	A

Tab. 11 ERP and Labelling data - 12 kW

Model(s): MADEIRA SOLAR KRBS 24	
Condensing boiler: yes	
Low-temperature (**) boiler: yes	
B1 boiler: no	
Cogeneration space heater: no	If yes, equipped with a supplementary heater: -
Combination heater: yes	

Item	Symbol	Value	Unit	Item	Symbol	Value	Unit	
Rated heat output	P_{rated}	23	kW	Seasonal space heating energy efficiency	η_s	91	%	
For boiler space heaters and boiler combination heaters: Useful heat output				For boiler space heaters and boiler combination heaters: Useful efficiency				
At rated heat output and high-temperature regime (*)	P_4	22,9	kW	At rated heat output and high-temperature regime (*)	η_4	86,5	%	
At 30 % of rated heat output and low-temperature regime (**)	P_1	7,6	kW	At 30 % of rated heat output and low-temperature regime (**)	η_1	95,9	%	
Auxiliary electricity consumption				Other items				
At full load	$e_{l,max}$	KRBS	0,032	kW	Standby heat loss	P_{stby}	0,049	kW
		KRBS-M	0,033		Ignition burner power consumption	P_{ign}	0,000	kW
		KRBS-V - KRBS-MV	0,034					
		KRBS-Z - KRBS-MZ	0,035					
At part load	$e_{l,min}$	KRBS	0,016	kW	Annual energy consumption	Q_{HE}	41	GJ
		KRBS-M	0,017		Emissions of nitrogen oxides	NO_x	29	mg/kWh
		KRBS-V - KRBS-MV	0,018					
		KRBS-Z - KRBS-MZ	0,019					
In standby mode	P_{SB}	KRBS	0,003	kW	Sound power level, indoors	L_{WA}	53	dba
		KRBS-M	0,004					
		KRBS-V - KRBS-MV	0,005					
		KRBS-Z - KRBS-MZ	0,006					
For combination heaters:								
Declared load profile	XXL			Water heating energy efficiency	η_{wh}	KRBS - KRBS-M-V-MV: 91 KRBS-Z-MZ: 90	%	
Daily electricity consumption	Q_{elec}	KRBS	0,171	kWh	Daily fuel consumption	Q_{fuel}	33,406	kWh
		KRBS-M	0,200					
		KRBS-V - KRBS-MV	0,224					
		KRBS-Z - KRBS-MZ	0,248					
Annual electricity consumption	AEC	KRBS	37	kWh	Annual fuel consumption	AFC	26	GJ
		KRBS-M	43					
		KRBS-V - KRBS-MV	49					
		KRBS-Z - KRBS-MZ	54					

Contact details: FONDITAL S.p.A. - Via Cerreto, 40 I-25079 VOBARNO (Brescia) Italia - Italy

(*) High-temperature regime means 60 °C return temperature at heater inlet and 80 °C feed temperature at heater outlet.

(**) Low temperature means for condensing boilers 30 °C, for low-temperature boilers 37 °C and for other heaters 50 °C return temperature (at heater inlet).

Seasonal space heating energy efficiency class	A
Water heating energy efficiency class	A

Tab. 12 ERP and Labelling data - 24 kW

Model(s): MADEIRA SOLAR KRBS 28

Condensing boiler: yes

Low-temperature (***) boiler: yes

B1 boiler: no

Cogeneration space heater: no

If yes, equipped with a supplementary heater: -

Combination heater: yes

Item	Symbol	Value	Unit	Item	Symbol	Value	Unit	
Rated heat output	P_{rated}	25	kW	Seasonal space heating energy efficiency	η_s	91	%	
For boiler space heaters and boiler combination heaters: Useful heat output				For boiler space heaters and boiler combination heaters: Useful efficiency				
At rated heat output and high-temperature regime (*)	P_4	25,4	kW	At rated heat output and high-temperature regime (*)	η_4	86,5	%	
At 30 % of rated heat output and low-temperature regime (**)	P_1	8,5	kW	At 30 % of rated heat output and low-temperature regime (**)	η_1	96,4	%	
Auxiliary electricity consumption				Other items				
At full load	$e_{l,max}$	KRBS	0,034	kW	Standby heat loss	P_{stby}	0,054	kW
		KRBS-M	0,035		Ignition burner power consumption	P_{ign}	0,000	kW
		KRBS-V - KRBS-MV	0,036			Annual energy consumption	Q_{HE}	45
		KRBS-Z - KRBS-MZ	0,037		Emissions of nitrogen oxides		NO_x	27
At part load	$e_{l,min}$	KRBS	0,016	kW		Sound power level, indoors	L_{WA}	54
		KRBS-M	0,018					
		KRBS-V - KRBS-MV	0,019					
		KRBS-Z - KRBS-MZ	0,020					
In standby mode	P_{SB}	KRBS	0,003	kW				
		KRBS-M	0,004					
		KRBS-V - KRBS-MV	0,005					
		KRBS-Z - KRBS-MZ	0,006					
For combination heaters:								
Declared load profile	XXL			Water heating energy efficiency	η_{wh}	KRBS - KRBS-M-V-MV: 91 KRBS-Z-MZ: 90	%	
Daily electricity consumption	Q_{elec}	KRBS	0,188	kWh	Daily fuel consumption	Q_{fuel}	33,347	kWh
		KRBS-M	0,217					
		KRBS-V - KRBS-MV	0,241					
		KRBS-Z - KRBS-MZ	0,265					
Annual electricity consumption	AEC	KRBS	41	kWh	Annual fuel consumption	AFC	26	GJ
		KRBS-M	47					
		KRBS-V - KRBS-MV	52					
		KRBS-Z - KRBS-MZ	58					

Contact details: FONDITAL S.p.A. - Via Cerreto, 40 I-25079 VOBARNO (Brescia) Italia - Italy

(*) High-temperature regime means 60 °C return temperature at heater inlet and 80 °C feed temperature at heater outlet.

(**) Low temperature means for condensing boilers 30 °C, for low-temperature boilers 37 °C and for other heaters 50 °C return temperature (at heater inlet).

Seasonal space heating energy efficiency class	A
Water heating energy efficiency class	A

Tab. 13 ERP and Labelling data - 28 kW

Model(s): MADEIRA SOLAR KRBS 32

Condensing boiler: yes

Low-temperature (**) boiler: yes

B1 boiler: no

Cogeneration space heater: no

If yes, equipped with a supplementary heater: -

Combination heater: yes

Item	Symbol	Value	Unit	Item	Symbol	Value	Unit	
Rated heat output	P_{rated}	29	kW	Seasonal space heating energy efficiency	η_s	KRBS - KRBS-M-V-MV: 93 KRBS-Z-MZ: 92	%	
For boiler space heaters and boiler combination heaters: Useful heat output				For boiler space heaters and boiler combination heaters: Useful efficiency				
At rated heat output and high-temperature regime (*)	P_4	29,4	kW	At rated heat output and high-temperature regime (*)	η_4	86,9	%	
At 30 % of rated heat output and low-temperature regime (**)	P_1	9,8	kW	At 30 % of rated heat output and low-temperature regime (**)	η_1	97,8	%	
Auxiliary electricity consumption				Other items				
At full load	$e_{l,max}$	KRBS	0,038	kW	Standby heat loss	P_{stby}	0,059	kW
		KRBS-M	0,039		Ignition burner power consumption	P_{ign}	0,000	kW
		KRBS-V - KRBS-MV	0,040					
		KRBS-Z - KRBS-MZ	0,041					
At part load	$e_{l,min}$	KRBS	0,017	kW	Annual energy consumption	Q_{HE}	52	GJ
		KRBS-M	0,018		Emissions of nitrogen oxides	NO_x	34	mg/kWh
		KRBS-V - KRBS-MV	0,019					
		KRBS-Z - KRBS-MZ	0,020					
In standby mode	P_{SB}	KRBS	0,003	kW	Sound power level, indoors	L_{WA}	54	dba
		KRBS-M	0,004					
		KRBS-V - KRBS-MV	0,005					
		KRBS-Z - KRBS-MZ	0,006					
For combination heaters:								
Declared load profile	XXL			Water heating energy efficiency	η_{wh}	KRBS: 89 KRBS-M-V-MV-Z-MZ: 88	%	
Daily electricity consumption	Q_{elec}	KRBS	0,196	kWh	Daily fuel consumption	Q_{fuel}	34,212	kWh
		KRBS-M	0,225					
		KRBS-V - KRBS-MV	0,249					
		KRBS-Z - KRBS-MZ	0,273					
Annual electricity consumption	AEC	KRBS	42	kWh	Annual fuel consumption	AFC	26	GJ
		KRBS-M	49					
		KRBS-V - KRBS-MV	54					
		KRBS-Z - KRBS-MZ	59					

Contact details: FONDITAL S.p.A. - Via Cerreto, 40 I-25079 VOBARNO (Brescia) Italia - Italy

(*) High-temperature regime means 60 °C return temperature at heater inlet and 80 °C feed temperature at heater outlet.

(**) Low temperature means for condensing boilers 30 °C, for low-temperature boilers 37 °C and for other heaters 50 °C return temperature (at heater inlet).

Seasonal space heating energy efficiency class	A
Water heating energy efficiency class	A

Tab. 14 ERP and Labelling data - 32 kW

3. Instructions for the installer

3.1 Installation standards

This boiler must be installed in compliance with the laws and standards in force in the country of installation, which are herein considered as entirely transcribed.

To find out about the gas category and technical specifications, refer to operation data and general features specified in the previous pages.



DANGER

Accessories and spare parts for installation and service procedures are to be supplied by the Manufacturer.

Should non original accessories and spare parts be employed, boiler proper performance is not guaranteed.

3.1.1 Packaging

The boiler is shipped in a wooden cage and secured to a wooden pallet with 4 screws.

Remove boiler from wooden cage and check its integrity.

The packing materials can be recycled. Disposal must be managed via appropriate waste collection sites.

Keep packaging out of reach of children, as it may be dangerous.

The manufacturer shall not be held responsible in case of damage to people, animals, or property due to failure to follow the above mentioned instructions.

The packaging contains a bag, which includes the following items:

- boiler installation, use and maintenance manual;
- air-intake blanking cap kit;
- one solar collector probe (PT1000).

3.2 Choosing where to install the boiler

The following must be taken into account when choosing where to install the boiler:

- indications contained in paragraph *Air intake and flue gas venting system* on page 46 and its sub-paragraphs.
- it is recommended to leave at least a 50-cm clearance on each side of the boiler to facilitate maintenance operations;
- do not install in locations with a corrosive or very dusty atmosphere, such as hairdresser salons, laundries etc., as this may severely reduce the lifespan of the components of the boiler;
- the place of installation must not be accessible to strangers, children and animals.

3.3 Installing the boiler



DANGER

Before connecting the boiler to CH and DHW networks, clean the pipes carefully.

Before commissioning a NEW system, clean it to remove any metal chips due to machining and welding, and any oil and grease that might negatively affect boiler operation or even damage it in case they get inside it.

Before commissioning a RECONDITIONED system (where radiators have been added, the boiler has been replaced, etc.) thoroughly clean it to remove any sludge and residues.

Clean the system using standard non acid products, available on the market.

Do not use solvents as they could damage system components.

Furthermore, in the central heating system (either new or reconditioned), it is always advisable to add to water a suitable percentage of corrosion protectants for multi-metal systems that will create a protective film onto all internal surfaces.

The manufacturer shall not be held responsible in case of damage to people, animals, or property due to failure to follow the above mentioned instructions.



DANGER

For all boiler installation types, it is necessary to install a filter which can be inspected (Y-shaped type) with Ø 0.4mm-mesh, on the return pipe before the boiler.

After transporting the boiler to the place of installation, proceed as follows to install it:

- open boiler central door;
- unscrew the screws securing the boiler to the wooden pallet;
- lift the boiler from the pallet and position it on the floor, taking care not to damage it;
- adjust the supporting feet, ensuring that the boiler is stable;
- prepare:
 - » a condensate drain (see Fig. 18 Condensate drain);
 - » an outlet for the 3-bar and 7-bar safety valves;
 - » an outlet for the 6-bar safety valve of the solar circuit (in case the latter opens, it will release a mixture of water and glycol, which should not be discharged into the sewers, but collected in a container instead).
- connect the boiler to cold water supply pipes, the heating flow and return pipes, the domestic hot water flow pipes from the water heater, the solar plant flow and return pipes (see par. *Hydraulic connections* on page 53).
- connect the boiler to pipe for condensate drain (refer to par. *Hydraulic connections* on page 53).
- provide a system for relieving the 3-bar safety valve and the 7-bar safety valve. Otherwise, the boiler manufacturer shall not be held responsible if the safety valves are activated and the room is flooded;
- provide a system for relieving the 6-bar safety valve of the solar circuit;
- connect the boiler to the air intake and flue gas venting system.
- connect the boiler to the gas supply system (refer to par. *Connection to gas mains* on page 53).
- connect power supply, ambient thermostat (optional) and other available accessories (see par. *Solar collector probe installation* on page 55 and following ones).

3.4 Boiler room ventilation

The boiler has sealed combustion chamber. Combustion air is not drawn from boiler room, therefore no specific recommendations need to be applied concerning the boiler room or openings and ventilation provided to the boiler room.



DANGER

the boiler must be installed in a room that is compliant with the legislation and standards in force in the country of installation, which are herein considered as entirely transcribed.

3.5 Air intake and flue gas venting system

Flue gas discharge into the atmosphere and air intake/flue gas venting systems must comply with applicable laws and standards in the country of installation that are considered as fully transcribed herein.



DANGER

The boiler is equipped with a safety device for flue gas exhaustion check.

It is strictly forbidden to tamper with and/or prevent operation of such safety device.

Should an air/flue gas system malfunction occur, the device will shut-down the boiler by interrupting the gas supply to the boiler and the LCD will display the E03 code.

In this case it is necessary to have safety device, boiler and the air intake/flue gas venting ducts promptly checked by a service centre or a qualified service engineer.

In case of repeated stops, it is necessary to have safety device, boiler and the air intake/flue gas venting ducts checked by a service centre or a qualified service engineer.

After each operation on the safety device or the air suction/flue gas exhaust system, it is necessary to perform a functional test of the boiler.

In case it is necessary to replace the safety device use only original spare parts supplied by the Manufacturer.



DANGER

For the air intake/flue gas venting systems, specific, manufacturer approved, condensate acid-resistant pipes and systems must be used, suitable for condensing boilers.



DANGER

Flue gas venting pipes are to be installed tilted toward the boiler so that condensate runs toward the combustion chamber, which is designed for condensate collection and drainage.

Should the above procedure not be possible, it is necessary to install, in condensate stagnation areas, devices designed for condensate collection and conveying to the condensate drain system.

It is necessary to avoid formation of condensate stagnation areas in the flue gas venting system, with the exception of the condensate trap possibly connected to the venting system itself.

The manufacturer cannot be held responsible for any damage caused by inappropriate boiler installation or operation, modification to the boiler, or due to non-observance of the instructions provided by the manufacturer or of legislation and standards applicable for the materials installed.

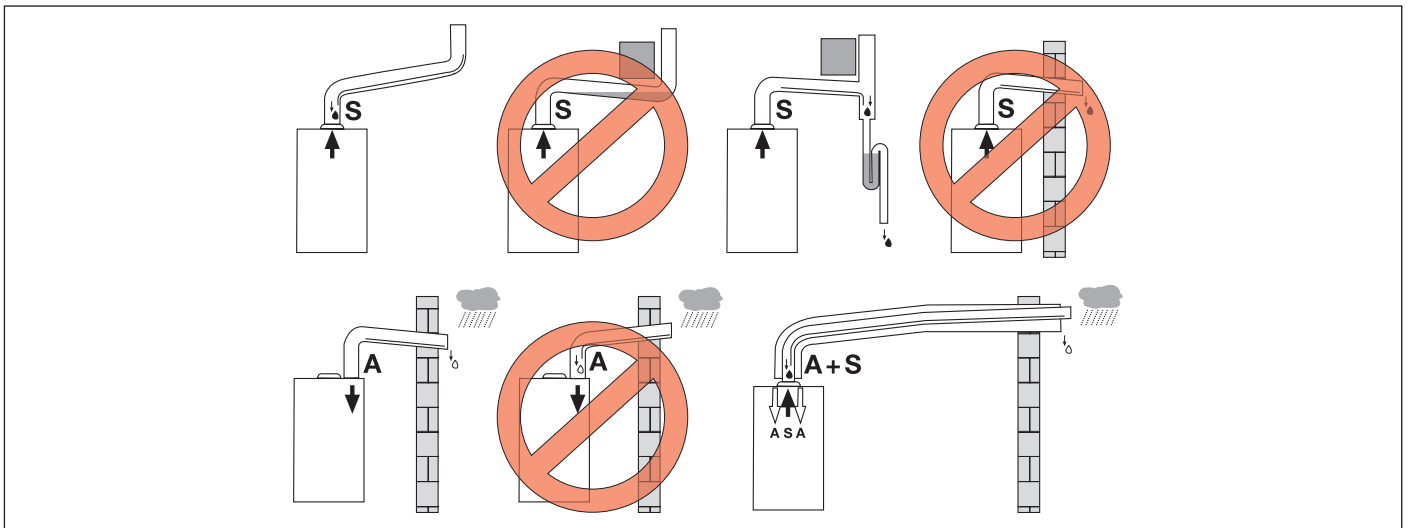

Fig. 10 Installation examples

KEY

- A Air intake
- S Flue gas vent

- Condensate
- Rain

3.5.1 Possible configuration of air intake and flue gas venting ducts

Type B23

Boiler intended for connection to an existing flue system external to the boiler room.

Combustion air is taken directly from the boiler room itself while flue gas is conveyed to the outside.

The boiler is not to be fitted with anti-wind gust device; it has to be equipped with a fan mounted before the combustion chamber/heat exchanger.

Type B53

Boiler intended for connection, via an independent duct, to the flue gas venting terminal.

Combustion air is taken directly from the boiler room itself while flue gas is conveyed to the outside.

The boiler is not to be fitted with anti-wind gust device; it has to be equipped with a fan mounted before the combustion chamber/heat exchanger.

Type C13

Boiler intended for connection to horizontal outlet and intake ducts connected to the outside by means of coaxial or split ducts.

The minimum distance between the air intake duct and the flue gas venting duct must be at least 250 mm, whereas both terminals must be contained within a square measuring 500 x 500 mm.

The boiler is to be equipped with a fan mounted before the combustion chamber/heat exchanger.

Type C33

Boiler intended for connection to vertical outlet and intake ducts connected to the outside by means of coaxial or split ducts.

The minimum distance between the air intake duct and the flue gas venting duct must be at least 250 mm, whereas both terminals must be contained within a square measuring 500 x 500 mm.

The boiler is to be equipped with a fan mounted before the combustion chamber/heat exchanger.

Type C43

Boiler intended for connection to collective chimney pipe system that includes two ducts, air intake and flue gas exhaustion. These ducts may be coaxial or split.

The chimney must be compliant with applicable legislation and standards.

The boiler is to be equipped with a fan mounted before the combustion chamber/heat exchanger.

Type C53

Boiler with separate pipes for combustion air intake and flue gas evacuation.

These flues may discharge in areas at a different pressure.

The terminals may not face each other from opposed walls.

The boiler is to be equipped with a fan mounted before the combustion chamber/heat exchanger.

Type C83

Boiler intended to be connected to combustion air terminal and to a single flue gas terminal or collective chimney.

The chimney must be compliant with applicable legislation and standards.

The boiler is to be equipped with a fan mounted before the combustion chamber/heat exchanger.

3.5.2 Ø 100/60 mm and Ø 125/80 mm air/flue gas coaxial duct system



WARNING

The information given above is with reference to air intake/flue gas venting ducts made from smooth, rigid pipes approved and supplied by the manufacturer.

C13 installation type

12 kW

- Minimum permissible length of horizontal coaxial pipes is 1 meter.
- Maximum permissible length of Ø100/60 mm horizontal coaxial pipes is 9 meters.
- Maximum permissible length of Ø125/80 mm horizontal coaxial pipes is 13.5 meters.
- For each additional 1 meter of straight pipe maximum permissible length is to be reduced by 1 meter.
- For each additional 90° elbow, maximum permissible length is to be reduced by 1 meter.
- For each additional 45° elbow, maximum permissible length is to be reduced by 0.5 meter.
- The wall terminal reduces maximum permissible length by 1.5 meters.
- The flow resistance of the first elbow shall not be taken into account to calculate maximum permissible length.
- The air intake duct is to be tilted down by 1% toward its exit, in order to avoid rain water to enter it.

24 kW

- Minimum permissible length of horizontal coaxial pipes is 1 meter without accounting for the first elbow connected to the boiler.
- Maximum permissible length of Ø 100/60 mm horizontal coaxial pipes is 10 meters including the first elbow connected to the boiler.
- Maximum permissible length of Ø 125/80 mm horizontal coaxial pipes is 14.5 meters including the first elbow connected to the boiler.
- For each additional 1 meter of straight pipe maximum permissible length is to be reduced by 1 meter.
- For each additional 90° elbow, maximum permissible length is to be reduced by 1 meter.
- For each additional 45° elbow, maximum permissible length is to be reduced by 0.5 meter.
- The wall terminal reduces maximum permissible length by 1.5 meters.
- The air intake duct is to be tilted down by 1% toward its exit, in order to avoid rain water to enter it.

28 kW

- Minimum permissible length of horizontal coaxial pipes is 1 meter.
- Maximum permissible length of Ø100/60 mm horizontal coaxial pipes is 9 meters.
- Maximum permissible length of Ø125/80 mm horizontal coaxial pipes is 13.5 meters.
- For each additional 1 meter of straight pipe maximum permissible length is to be reduced by 1 meter.
- For each additional 90° elbow, maximum permissible length is to be reduced by 1 meter.
- For each additional 45° elbow, maximum permissible length is to be reduced by 0.5 meter.
- The wall terminal reduces maximum permissible length by 1.5 meters.
- The flow resistance of the first elbow shall not be taken into account to calculate maximum permissible length.
- The air intake duct is to be tilted down by 1% toward its exit, in order to avoid rain water to enter it.

32 kW

- Minimum permissible length of horizontal coaxial pipes is 1 meter without accounting for the first elbow connected to the boiler.
- Maximum permissible length of Ø 100/60 mm horizontal coaxial pipes is 7 meters including the first elbow connected to the boiler.
- Maximum permissible length of Ø 125/80 mm horizontal coaxial pipes is 10.5 meters including the first elbow connected to the boiler.
- For each additional 1 meter of straight pipe maximum permissible length is to be reduced by 1 meter.
- For each additional 90° elbow, maximum permissible length is to be reduced by 1 meter.
- For each additional 45° elbow, maximum permissible length is to be reduced by 0.5 meter.
- The wall terminal reduces maximum permissible length by 1.5 meters.
- The air intake duct is to be tilted down by 1% toward its exit, in order to avoid rain water to enter it.

C33 installation type

12 kW

- Minimum permissible length of vertical coaxial pipes is 1 meter.
- Maximum permissible length of Ø 100/60 mm vertical coaxial pipes is 9 meters.
- Maximum permissible length of Ø 125/80 mm vertical coaxial pipes is 13.5 meters.
- For each additional 1 meter of straight pipe maximum permissible length is to be reduced by 1 meter.
- For each additional 90° elbow, maximum permissible length is to be reduced by 1 meter.
- For each additional 45° elbow, maximum permissible length is to be reduced by 0.5 meter.
- The roof vent terminal reduces maximum permissible length by 1.5 meters.

24 kW

- Minimum permissible length of vertical coaxial pipes is 1 meter.
- Maximum permissible length of Ø 100/60 mm vertical coaxial pipes is 10 meters.
- Maximum permissible length of Ø 125/80 mm vertical coaxial pipes is 14.5 meters.
- For each additional 1 meter of straight pipe maximum permissible length is to be reduced by 1 meter.
- For each additional 90° elbow, maximum permissible length is to be reduced by 1 meter.
- For each additional 45° elbow, maximum permissible length is to be reduced by 0.5 meter.
- The roof vent terminal reduces maximum permissible length by 1.5 meters.

28 kW

- Minimum permissible length of vertical coaxial pipes is 1 meter.
- Maximum permissible length of Ø 100/60 mm vertical coaxial pipes is 9 meters.
- Maximum permissible length of Ø 125/80 mm vertical coaxial pipes is 13.5 meters.
- For each additional 1 meter of straight pipe maximum permissible length is to be reduced by 1 meter.
- For each additional 90° elbow, maximum permissible length is to be reduced by 1 meter.
- For each additional 45° elbow, maximum permissible length is to be reduced by 0.5 meter.
- The roof vent terminal reduces maximum permissible length by 1.5 meters.

32 kW

- Minimum permissible length of vertical coaxial pipes is 1 meter.
- Maximum permissible length of Ø 100/60 mm vertical coaxial pipes is 7 meters.
- Maximum permissible length of Ø 125/80 mm vertical coaxial pipes is 10.5 meters.
- For each additional 1 meter of straight pipe maximum permissible length is to be reduced by 1 meter.
- For each additional 90° elbow, maximum permissible length is to be reduced by 1 meter.
- For each additional 45° elbow, maximum permissible length is to be reduced by 0.5 meter.
- The roof vent terminal reduces maximum permissible length by 1.5 meters.

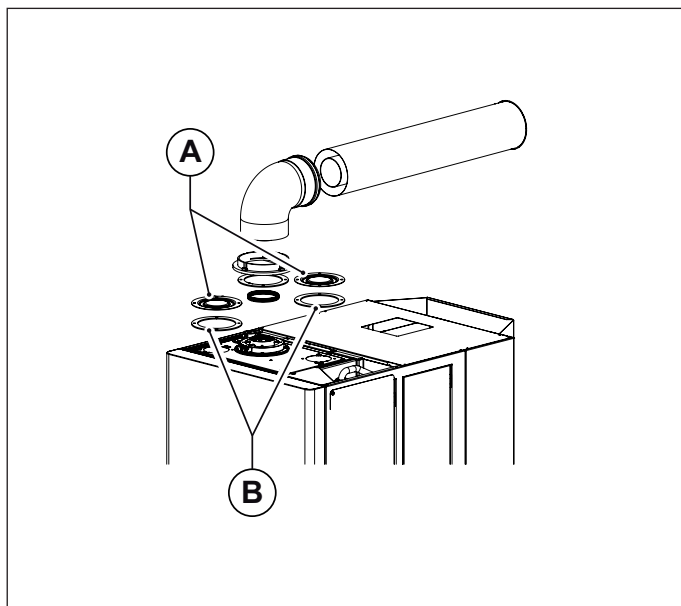

Fig. 11 Coaxial ducts C33

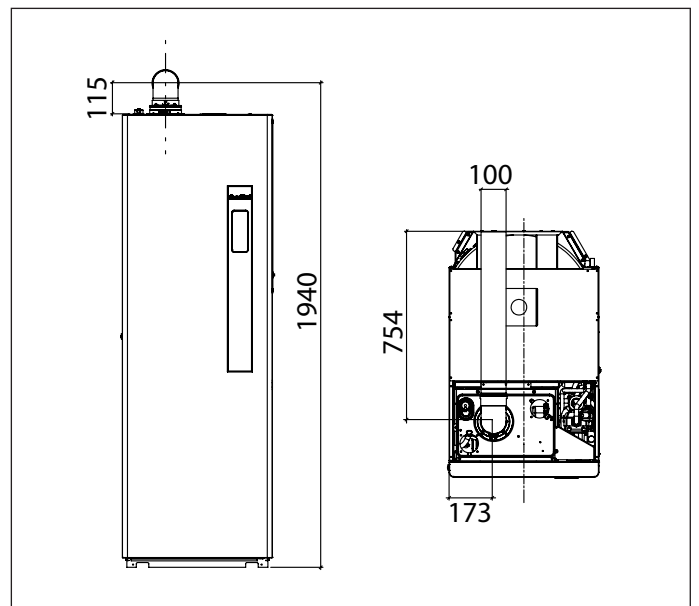

Fig. 12 Coaxial ducts C33 distance specs

- A.** Blanking cap
- B.** Gasket

3.5.3 Air intake and flue gas venting via 80 mm split pipes

Installation types C43 - C53 - C83

12 kW

- Minimum permissible length of air intake pipe is 1 meter.
- Minimum permissible length of flue gas venting pipe is 1 meter.
- Maximum permissible length of intake/flue gas venting pipes is 152 meters (combined length of air intake and flue gas venting pipe).
- For each additional 1 meter of straight pipe maximum permissible length is to be reduced by 1 meter.
- For each additional 90° elbow, maximum permissible length is to be reduced by 1 meter.
- For each additional 45° elbow, maximum permissible length is to be reduced by 0.5 metres for flue gas venting pipes and by 1.0 metre for air intake pipes.
- The roof terminal reduces maximum permissible length by 5 meters.
- The wall terminal reduces maximum permissible length by 4.5 meters.

24 kW

- Minimum permissible length of air intake pipe is 1 meter.
- Minimum permissible length of flue gas venting pipe is 1 meter.
- Maximum permissible length of intake/flue gas venting pipes is 84 meters (combined length of air intake and flue gas venting pipe).
- For each additional 1 meter of straight pipe maximum permissible length is to be reduced by 1 meter.
- For each additional 90° elbow, maximum permissible length is to be reduced by 1 meter.
- For each additional 45° elbow, maximum permissible length is to be reduced by 0.5 meter.
- The roof terminal reduces maximum permissible length by 5.5 meters.
- The wall terminal reduces maximum permissible length by 5 meters.

28 kW

- Minimum permissible length of air intake pipe is 1 meter.
- Minimum permissible length of flue gas venting pipe is 1 meter.
- Maximum permissible length of intake/flue gas venting pipes is 91 meters (combined length of air intake and flue gas venting pipe).
- For each additional 1 meter of straight pipe maximum permissible length is to be reduced by 1 meter.
- For each additional 90° elbow, maximum permissible length is to be reduced by 1.5 meter.
- For each additional 45° elbow, maximum permissible length is to be reduced by 1 meter.
- The roof terminal reduces maximum permissible length by 5.5 meters.
- The wall terminal reduces maximum permissible length by 5.5 meters.

32 kW

- Minimum permissible length of air intake pipe is 1 meter.
- Minimum permissible length of flue gas venting pipe is 1 meter.
- Maximum permissible length of intake/flue gas venting pipes is 78 meters (combined length of air intake and flue gas venting pipe).
- For each additional 1 meter of straight pipe maximum permissible length is to be reduced by 1 meter.
- For each additional 90° elbow, maximum permissible length is to be reduced by 1.5 meter.
- For each additional 45° elbow, maximum permissible length is to be reduced by 1 meter.
- The roof terminal reduces maximum permissible length by 6 meters.
- The wall terminal reduces maximum permissible length by 5.5 meters.

3.5.4 Air intake and flue gas venting via 60 mm split pipes

Installation types C43 - C53 - C83

12 kW - 24 kW - 28 kW - 32 kW

- Minimum permissible length of air intake pipe is 1 meter.
- Minimum permissible length of flue gas venting pipe is 1 meter.
- Maximum permissible length of intake/flue gas venting pipes is 39 meters for the 12 kW model, 23 meters for the 24 kW - 28 kW models and of 20 meters for the 32 kW model (combined length of air intake and flue gas venting pipe).
- For each additional 1 meter of straight pipe maximum permissible length is to be reduced by 1 meter.
- For each additional 90° elbow, maximum permissible length is to be reduced by 1 meter.
- For each additional 45° elbow, maximum permissible length is to be reduced by 0.5 meter.
- The wall terminal reduces maximum permissible length by 4 metres for the 12 kW model and by 4.5 metres for the 24 kW - 28 kW - 32 kW models.

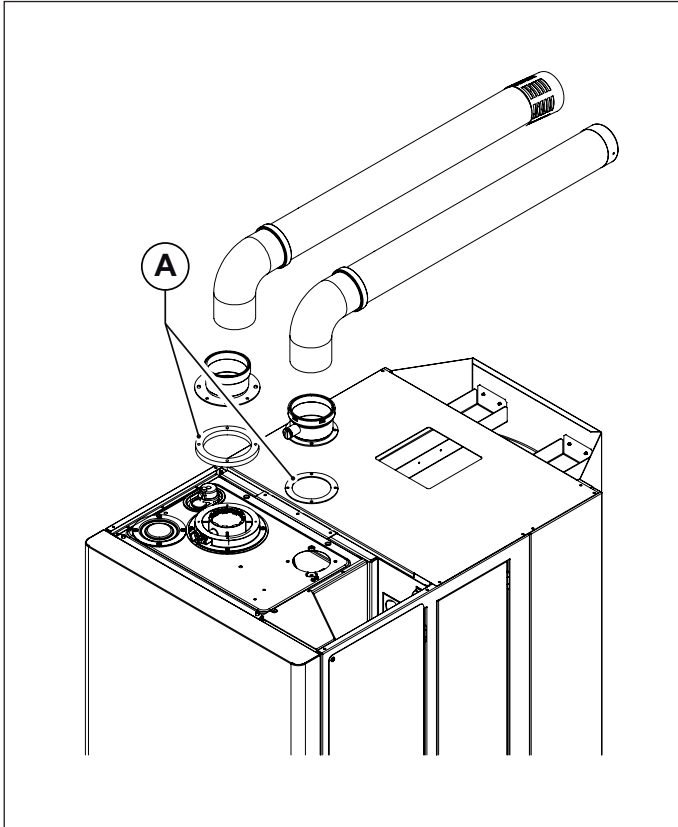

Fig. 13 Coaxial ducts C43 - C53 - C83

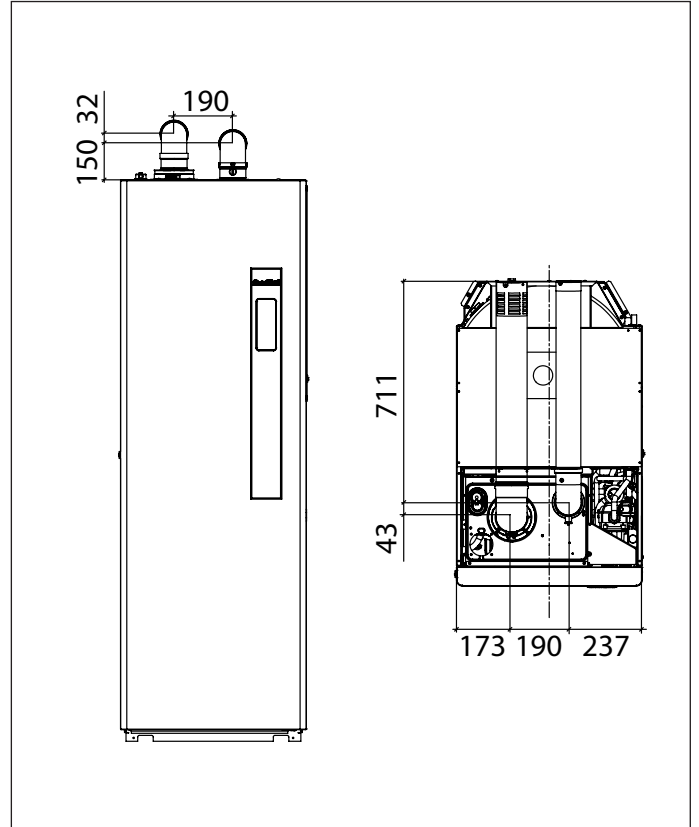







Fig. 14 Coaxial ducts C43 - C53 - C83 distance specs

A. Gasket

3.6 Checking combustion efficiency

3.6.1 Flue cleaning function

- The boiler features a flue cleaning function which must be used to measure combustion efficiency during operation and to adjust the burner.
- To enable the flue cleaning function, press the  key and keep it pressed for 3 seconds.
- The  symbol steady on and the fan speed indicate that the flue cleaning function is active.
- The display shows the flow temperature and the  symbol, if burner is on. The boiler performs the ignition sequence and then operates at the burner maximum output (parameter **P4**).
- The keys active in this function are:  and **DHW +/-**.
- By pressing the **DHW +/-** keys it is possible to change the fan speed from **P5** (minimum speed) to **P4** (maximum speed). The display shows the wrench symbol (indicating that the parameter is being edited), the broom, the **H** letter (indicating Hertz), the speed set-point value in Hz, the fan current speed, and the lit flame on symbol if burner is on.
- As soon as the **DHW +/-** key is released again, the display will show fan current rpm value, flow temperature, system pressure, the lit flame on symbol, the  symbol to indicate that the flue cleaning function is active.
- The flue cleaning function lasts 15 minutes. To quit this function, press  and you will go back to the standard operating mode.

3.6.2 Measurement procedure

Reference standards: UNI 10389, UNI 10642

The boiler is equipped with a tower allowing for air intake/flue gas venting pipe connection (see Fig. 15 Plugs position and Fig. 16 Hole position).

The tower is designed with two pre-arranged openings directly accessing air and flue gas ducts (see Fig. 15 Plugs position).

Remove caps **A** and **B** from the pre-arranged openings on the tower, before starting combustion checking procedure (see Fig. 15 Plugs position).

In order to verify combustion efficiency the following measurements must be implemented:

- assess combustion air from opening **1** (see Fig. 16 Hole position).
- assess flue gas temperature and CO₂ from opening **2** (see Fig. 16 Hole position).
- Allow boiler to reach working temperature before taking any measurement.

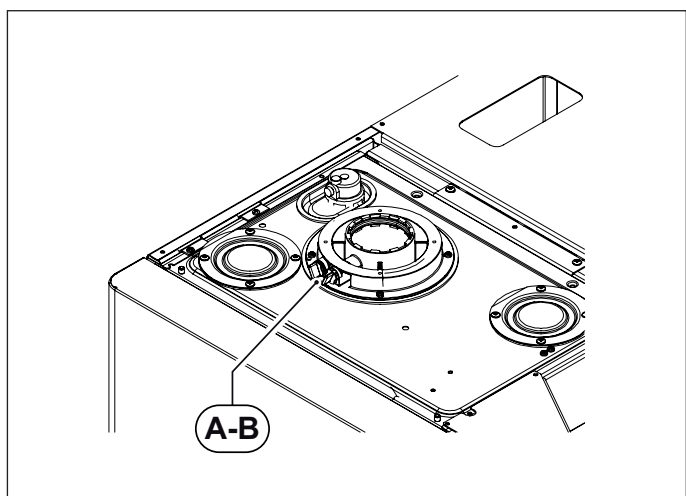

Fig. 15 Plugs position

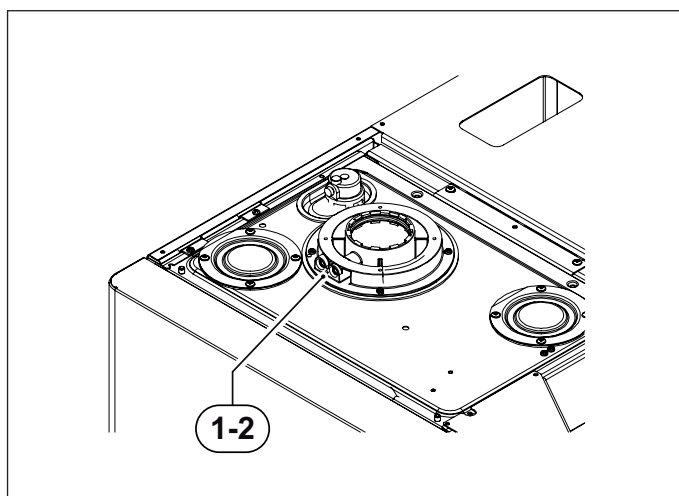

Fig. 16 Hole position

3.7 Connection to gas mains

Cross-section gas pipe size must be chosen depending on its length, layout pattern, gas flow rate.
Gas supply pipe cross-section must be equal or greater than boiler gas pipe.



DANGER

Comply with installation standards enforced in the country where the boiler is installed which are considered as fully transcribed in this booklet.

Remember that before operating an indoor gas distribution system and before connecting it to a meter, it must be checked for leaks.

If some system parts are not visible, the leak test is to be carried out before the pipes are covered.

Leak test is NOT to be carried out employing flammable gas: use air or nitrogen for this purpose.

Once gas is in the pipes, leak test by a naked flame is forbidden; use specific products available on the market.

When connecting the boiler to gas supply network, it is COMPULSORY to install an appropriately sized gasket (A) made from suitable material (see Fig. 17 Connection to gas mains).

The boiler gas inlet coupling is NOT suitable for hemp, teflon tape or similarly made gaskets.

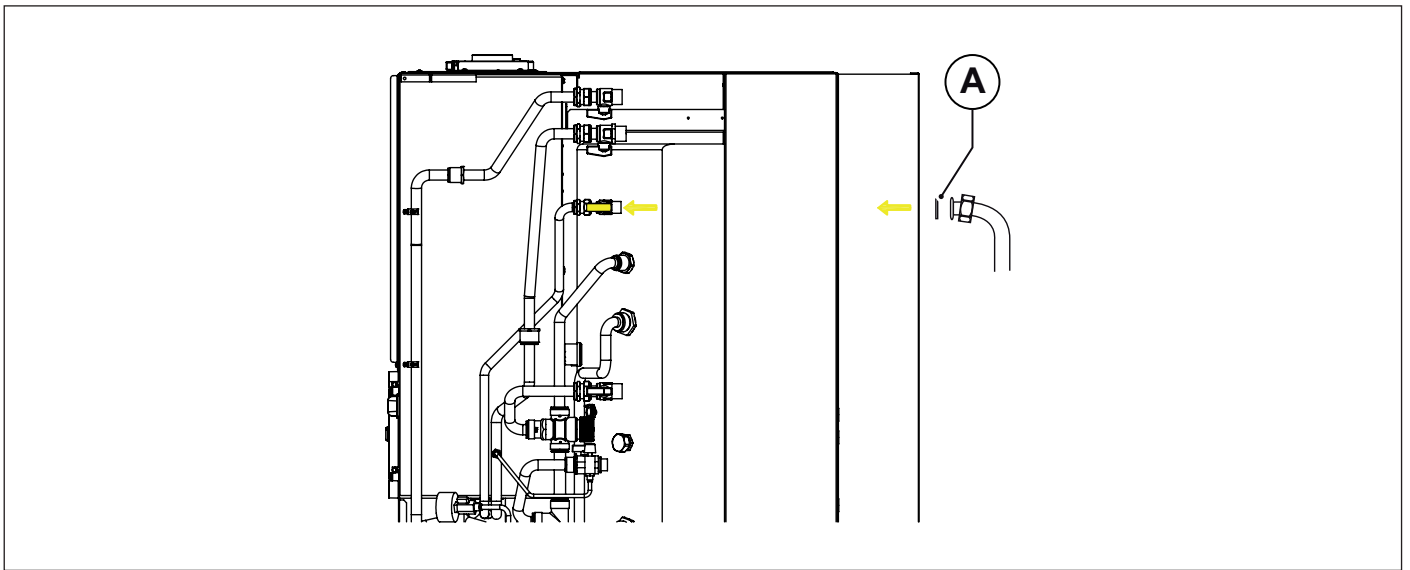

Fig. 17 Connection to gas mains

3.8 Hydraulic connections

3.8.1 Central heating

Prior to installing the boiler, the hydraulic system is to be cleaned in order to remove impurities; they could be present in system components and damage the pump and the heat exchanger.

The CH outlet and return pipes must be connected to the respective connectors on the boiler (see *Boiler layouts* on page 36).

When calculating the cross section of CH system pipes, bear in mind load losses induced by radiators, thermostatic valves, radiator gate valves, and the configuration of the system itself.



WARNING

It is advisable to convey the discharge flow of boiler safety valve to the sewer system. Should the above precaution not be implemented and the safety valve be activated, boiler room flooding may occur.

The manufacturer shall not be held responsible in case of damage to people, animals, or property due to failure to follow the above mentioned instructions.

3.8.2 DHW

Prior to installing the boiler, the hydraulic system is to be cleaned in order to remove impurities; they could be present in system components and damage the boiler.

Cold water inlet and DHW outlet shall be connected to the boiler through the dedicated fittings (see *Hydraulic connections* on page 53).



WARNING

Depending on the hardness of the mains water supply, ascertain whether or not to install appropriate domestic water treatment systems using water treatment products suitable for drinking water and compliant with the regulations and standards in force in the country of installation.

Water treatment is always advisable when water supplied to the boiler is more than 20°F hard.

Water supplied by commonly marketed water softeners, due to PH level induced in water, may not be compatible with some components in the system.

3.8.3 Solar collectors

Connection to solar collectors is made by connecting the solar flow pipe (from collectors to boiler) and solar return pipe (from boiler to collectors) to the relevant fittings as shown in the figures about hydraulic connections.

3.8.4 Condensate drain

Comply with condensate drain laws and standards applicable in the country of installation, which are considered herein integrally transcribed. Unless forbidden, the condensate produced by combustion is to be routed via the condensate drain through a discharge system connected to the domestic sewer, which due to its basicity, counteracts flue gas condensate acidity. In order to avoid domestic sewer odour to reach the premises, it is advisable to install an appropriate device between the discharge system and the domestic sewer. The condensate drain system and the domestic discharge system is to be made of an adequate, condensate-resistant material.



WARNING

The manufacturer shall not be held responsible in case of damage to people, animals, or property due to failure to follow the above mentioned instructions.

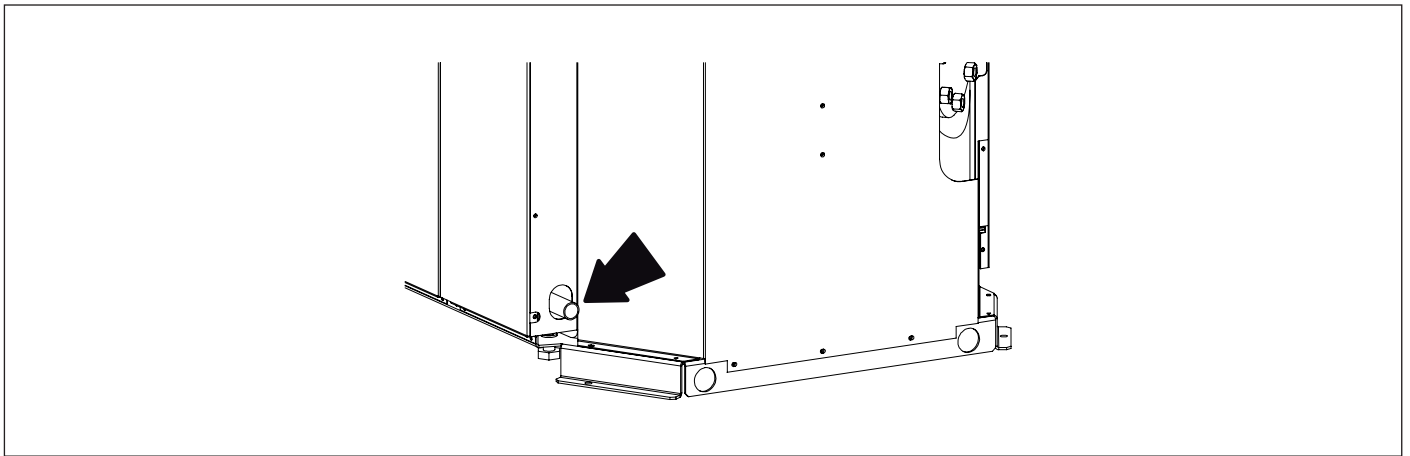

Fig. 18 Condensate drain

3.8.5 Thermal discharge

The connection to an additional user for thermal discharge (M, MV and MZ versions) can be made by connecting the thermal discharge flow pipe and the thermal discharge return pipe as shown in the figures about hydraulic connections.

3.9 Solar collector probe installation

The boiler is equipped with a solar plant temperature probe that must be installed by a qualified engineer.

The probe must be installed between the boiler and the solar field. If the supplied cable is not long enough, add an extension by using a 2-wire shielded outdoor cable.

The two probe cables must be connected to pins 11 and 12 of the boiler electronic board (see par. *Wiring diagrams* on page 69). The probe sensor must be installed on the solar field to detect the output temperature of the same (see solar collector instructions).

3.10 Connection to electrical mains

The boiler is supplied with a three-poled power cable, already connected to the electronic board and it is provided with a safety clamp.

The boiler is to be connected to a 230V-50Hz electrical power supply.

When connecting it to power mains, follow correct phase / neutral polarity sequence.

Installation standards must be complied with and they are herein considered as entirely transcribed.

An easily accessible two-poled switch, with a minimum 3 mm distance between contacts, is to be installed ahead of the boiler. The switch is to allow power supply cut-off in order to safely perform maintenance and service procedures.

Power supply to the boiler must be fitted with a residual-current circuit breaker having suitable disconnection capacity. Electric power supply must be properly earthed.

The above mentioned safety measure must be verified. If in doubt, ask a qualified technician to thoroughly check the power network.



WARNING

The manufacturer cannot be held responsible for any damage caused by failure to earth the system correctly: gas, water, or CH system pipes are not suitable for grounding power networks.

3.10.1 Selecting the operating range in heating mode

Heating water temperature adjustment range depends on the selected operating range:

- **standard range:** from 20°C to 78°C (pressing **CH +/-**);
- **reduced range:** from 20°C to 45°C (pressing **CH +/-**).

The standard range is active with curves **P10** ≥ 1 , while the reduced range is active with curves **P10** < 1 .

The two ranges can also be selected even with the external probe disconnected.

The waiting time between one boiler ignition and the following one, used to prevent boiler frequent turning on and off is 4 minutes for both ranges, and can be edited with the parameter **P11**.

If system water temperature decreases below a certain value, the waiting time is reset and the boiler re-ignited, as shown in the following table:

Selected range	Re-ignition temperature
Standard range	$< 40^{\circ}\text{C}$ (P27)
Reduced range	$< 20^{\circ}\text{C}$

Tab. 15 Boiler re-ignition temperature

Operation range selection is to be implemented by a installer or a qualified Service Centre.

3.11 Connection to ambient thermostat (optional)

The boiler is designed to be connected to an ambient thermostat (optional, not compulsory).

Ambient thermostat contacts must be properly sized in compliance with a load of 5 mA at 24 Vdc.

The ambient thermostat cables must be connected to terminals 1 and 2 of the electronic board (see par. *Wiring diagrams* on page 69) after having eliminated the jumper supplied as a standard with the boiler.

The ambient thermostat cables are not to be grouped together in the same sheath as power mains supply cables.

3.12 Installation and operation with Open Therm Remote Control (optional)



WARNING

Only use original Remote Control Units supplied by the manufacturer.

The correct operation of the Remote Control itself and of the boiler is not guaranteed if non original Remote Control units not supplied by the manufacturer are used.

The boiler may be connected to an Open Therm Remote Control (non-compulsory optional accessory supplied by manufacturer).

The Remote Control must only be installed by qualified personnel.

To install the Remote Control, refer to the instructions provided with the Remote Control itself.

The Remote Control must be installed on an indoor wall at a height of approximately 1.5 m from the floor and in a suitable location for measuring ambient temperature: do not install in recess or corners, behind doors or curtains, and install away from heat sources, direct sunlight, air draughts and water sprays.

The Remote Control connector is protected against inverted polarity, and the connections may be inverted.



WARNING

Do not connect the remote control to mains electrical power 230 V ~ 50 Hz.

The remote control wiring must not be grouped together in the same sheath as the power cables: if the cables are sheathed together, electrical interference from the power cables may compromise the functions of the Remote Control;

For complete instructions on how to program the Remote Control, refer to the instruction manual included in the Remote Control kit.

Board and Remote Control communicate in each operating mode: OFF, SUMMER, WINTER, CH ONLY.

Boiler display layout corresponds to the setting made from the Remote Control, as for the operating mode.

The remote control may be used to view and set a number of special parameters denominated **TSP** parameters and reserved solely for qualified technicians.

TSP0 parameter sets default data table and restores all factory settings, cancelling all preceding modifications on single parameters.

If a single parameter is found to be incorrect, the value given in the default value table is restored.

If the user attempts to set a value not within the permissible range for the parameter, the new value is rejected and the existing value is maintained.

Parameter	Configurable value range	12 kW natural gas	12 kW propane	24 kW natural gas	24 kW propane	28 kW natural gas	28 kW propane	32 kW natural gas	32 kW propane
P0 - TSP0 Equipment type and default data chart	1 - 7	0	5	1	3	2	4	6	7
P4 - TSP4 Fan speed at burner maximum output (DHW)	TSP5 ÷ 250 Hz	187 Hz	185 Hz	199 Hz	194 Hz	201 Hz	198 Hz	210 Hz	205 Hz
P5 - TSP5 Fan speed at burner minimum power (DHW and heating)	25 ÷ 120 Hz	39 Hz	39 Hz	42 Hz	42 Hz	40 Hz	40 Hz	43 Hz	43 Hz
P6 - TSP6 Fan speed at ignition power and propagation	25 ÷ 160 Hz	48 Hz	48 Hz	58 Hz	58 Hz	60 Hz	60 Hz	76 Hz	76 Hz
P7 - TSP7 Upper limit for maximum CH output	10 ÷ 100 %	75%	74%	88%	88%	87%	87%	88%	88%
P8 - TSP8 Negative ramp start minimum speed	P5 ÷ P6	56	56	56	56	60	60	60	60
P9 - TSP9 Negative ramp time	0 ÷ 30 (1 = 10 sec.)	18	18	18	18	25	25	18	18
P10 - TSP10 Heating output curves	0 ÷ 3	1.5	1.5	1.5	1.5	1.5	1.5	1.5	1.5

Tab. 16 Limits to be set for TSP parameters and default values in relation to boiler type (TSP0)

3.12.1 Installation of the (optional) external probe and sliding temperature operation

The boiler can be connected to an (optional) external temperature probe (optional, provided by the manufacturer) for sliding temperature operation.



WARNING

Only original external temperature probes supplied by the manufacturer must be used.

If non-original external temperature probes are used, correct operation of the boiler and external probe cannot be guaranteed.

The external temperature probe must be connected by means of a double insulated wire, minimum cross-section 0.35 sq.mm.

The external probe must be connected to pins **5-6** of boiler electronic board (see par. *Wiring diagrams* on page 69).



WARNING

The temperature probe cables must NOT be routed together with power cables.

The temperature probe must be installed on an outside wall facing NORTH - NORTH EAST, in a position protected from weather.

Do not install near a window, ventilation openings or sources of heat.

The external temperature probe automatically modifies the CH flow temperature in relation to:

- Measured external temperature.
- Selected thermoregulation curve.
- Selected fictitious ambient temperature.

The fictitious ambient temperature is set using **CH +/-** buttons that, with external probe installed, no longer work to set the heating water temperature (see *Operation with external probe (optional)* on page 26).

Through boiler parameter **P30** it is possible to display the value of the outside temperature detected by the external probe.

With installed external probe, press +/- **CH** buttons to set calculated ambient temperature. As soon as the button is released, icon  will continue flashing for approx. 3 seconds, and the calculated ambient temperature value will flash as well.

After this time, value is stored and display standard operation will be restored.

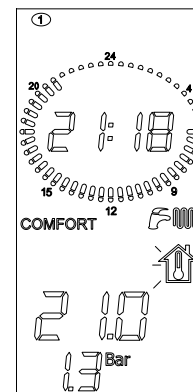

The figure shows the curves for a fictitious ambient temperature of 20°C. Parameter **P10** allows selecting the curve value shown (see Fig. 19 Thermoregulation curves).

If fictitious ambient temperature value is edited on boiler display, the curves shift up or down, respectively, by the same amount.

With a fictitious ambient temperature setting of 20°C, for example, if you select the curve corresponding to parameter 1 and the outdoor temperature is -4°C, the CH flow temperature will be 50°C.

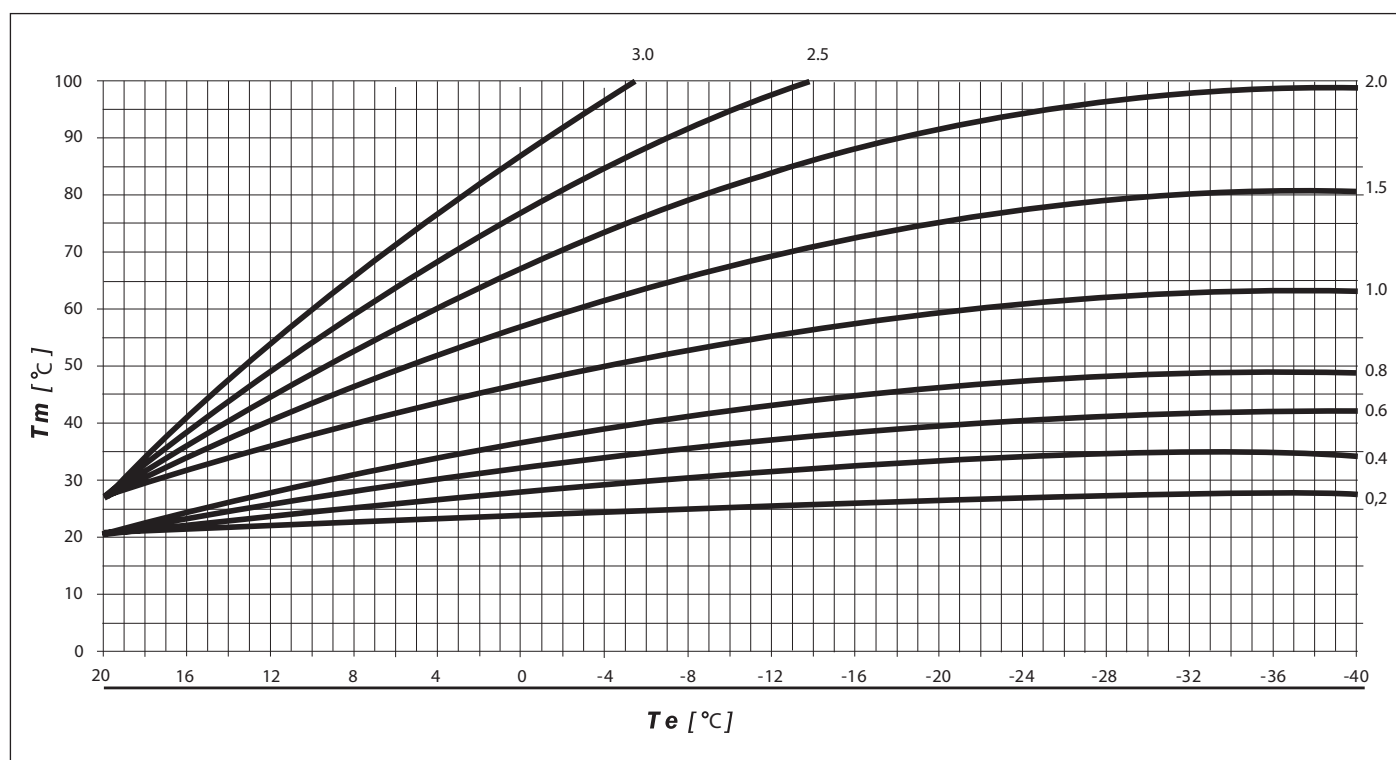



Fig. 19 Thermoregulation curves

Tm indicates flow water temperature in °C

Te indicates external temperature in °C

3.13 TSP parameters

The boiler operation is controlled by several parameters.

To change the parameters, press  and  at the same time for 3 seconds.

Scroll through the parameters by pressing **CH +/-** buttons.

Set onto the required one and press .

The  symbol turns on to indicate that you can edit the parameter value.

The parameter value can be edited using **CH +/-** buttons.

To confirm modification press .

To quit the parameter editing mode press .

Parameter	Settable values	Default values	Notes
P0 - TSP0 Boiler power selection	0 ÷ 7	According to the model	0 = 12 kW natural gas; 1 = 24 kW natural gas; 2 = 28 kW natural gas; 3 = 24 kW propane; 4 = 28 kW propane; 5 = 12 kW propane; 6 = 32 kW natural gas; 7 = 32 kW propane.
P4 - TSP4 Fan speed at burner maximum output	TSP5 ÷ 250 Hz	According to the model	12 kW natural gas = 187; 24 kW natural gas = 199; 28 kW natural gas = 201; 24 kW propane = 194; 28 kW propane = 198; 12 kW propane = 185; 32 kW natural gas = 210; 32 kW propane = 205.
P5 - TSP5 Fan speed at burner minimum output	25 - 120 Hz	According to the model	12 kW = 39; 24 kW = 42; 28 kW = 40; 32 kW = 43
P6 - TSP6 Fan speed at ignition power	25 - 160 Hz	According to the model	12 kW = 48; 24 kW = 58; 28 kW = 60; 32 kW = 76
P7 - TSP7 Fan speed at heating maximum output	10 ÷ 100%	According to the model	12 kW natural gas = 75; 12 kW propane = 74; 24 and 32 kW = 88; 28 kW = 87.
P8 - TSP8 Negative ramp start minimum speed	P5 ÷ P6	According to the model	12 and 24 kW = 56; 28 and 32 kW = 60
P9 - TSP9 Negative ramp time	0 ÷ 30 (1 = 10 sec.)	According to the model	12, 24 and 32 kW = 18; 28 kW = 25
P10 - TSP10 Heating output curves	0 ÷ 3	1.5	Resolution 0.05
P11 - TSP11 Heating thermostat timing	0 ÷ 10 min.	4	-
P12 - TSP12 CH power rising ramp timer	0 ÷ 10 min.	1	-
P13 - TSP13 Timer for CH post-circulation, freeze protection and flue cleaning function, configurable	30 ÷ 180 sec.	30	-
P14 - TSP14 Setting of "solar" DHW thermostats	0 ÷ 1	0	0 = normal; 1 = solar
P15 - TSP15 Water hammer protection delay, configurable	0 ÷ 10 sec.	0	-

Tab. 17 List of parameters - I

Parameter	Settable values	Default values	Notes
P16 - TSP16 Ambient thermostat reading delay / OT	0 ÷ 199 sec.	0	-
P17 - TSP17 Multifunction relay setting	0 ÷ 3	According to the model	0 = shut-down and malfunction; 1 = ambient thermostat request 1/Remote control; 2 = solar; 3 = ambient thermostat request 2
From P18 to P26 see "Solar parameters (with P17=2 or with supplementary board)			
P27 - TSP27 Heating timer reset temperature	20 ÷ 78 °C	-	P10 < 1 (low temp.) = 20 °C; P10 > 1 (high temp.) = 40 °C
P29 - TSP29 Setting of default parameters (except P0, P1, P2, P17)	0 ÷ 1	0	0 = user parameters; 1 = default parameters.
From P30 to P50 see "Display only"			
P51 SA1 ambient probe triggering differential OFF	0.0 ÷ 1.0 °C	0.0 °C	only with connected ambient probe
P52 SA1 ambient probe triggering differential ON	-1.0 ÷ -0.1 °C	-0.5 °C	only with connected ambient probe
P53 Ambient probe SA1 correction range	-5.0 ÷ 5.0 °C	0.0 °C	only with connected ambient probe
P54 SA2 ambient probe triggering differential OFF	0.0 ÷ 1.0 °C	0.0 °C	only with connected ambient probe
P55 SA2 ambient probe triggering differential ON	-1.0 ÷ -0.1 °C	-0.5 °C	only with connected ambient probe
P56 Ambient probe SA2 correction range	-5.0 ÷ 5.0 °C	0.0 °C	only with connected ambient probe
P57 Type of modulation with connected ambient probes (only if P61 is between 03 and 07)	0 ÷ 4	4	0 = on/off; 1 = ambient probe modulation; 2 = external probe modulation; 3 = ambient probe and external probe modulation; 4 = no ambient probe connected.
P58 Ambient probe weight during modulation	0 ÷ 20 °C	8 °C	used for thermoregulation with P57=3

Tab. 18 List of parameters - II

Parameter	Settable values	Default values	Notes
P59 Type of temperature visualization on display	0 ÷ 7	0	0 = flow temp.; 1 = SA1 probe temp.; 2 = SA2 probe temp.; 3 = external temp.; 4 = water heater temp.; 5 = solar coll. temp.; 6 = solar valve temp.; 7 = solar valve temp from solar board
P60 Number of additional boards connected	0 ÷ 4	According to the model	Maximum 4 boards (3 zone + 1 solar)
P61 Association of remote control, thermostat and ambient probe for the control of zone 1 and zone 2	00 ÷ 07	00	00 = remote zone 2 / TA2 zone 1; 01 = TA1 zone 2 / TA2 zone 1; 02 = TA2 zone 2 / remote zone 1; 03 = SA1 zone 1 / TA2 zone 2; 04 = SA1 zone 1 / SA2 zone 2; 05 = remote zone 1 / SA2 zone 2; 06 = zone 1 not managed / SA2 zone 2; 07 = TA1 zone 1 / SA2 zone 2.
P62 Selection of zone 2 curve	0 ÷ 3	0.6	V, Z, MV and MZ versions
P63 Zone 2 set-point (fictitious temp.)	15 ÷ 35 °C	20 °C	V, Z, MV and MZ versions
P66 Selection of zone 3 curve	0 ÷ 3	0.6	Z and MZ versions
P67 Zone 3 set-point (fictitious temp.)	15 ÷ 35 °C	20 °C	Z and MZ versions
P70 Selection of zone 4 curve	0 ÷ 3	0.6	not used
P71 Zone 4 set-point (fictitious temp.)	15 ÷ 35 °C	20 °C	not used
P74 Low temperature zone mixer valve opening time	0 ÷ 300 sec.	140 sec.	V, Z, MV and MZ versions
P75 Rise in nominal boiler temperature with zone board	0 ÷ 35 °C	5 °C	V, Z, MV and MZ versions
P76 Thermal discharge enabling with solar board	0 ÷ 1	0 1 (M, MV and MZ versions)	0 = disabled; 1 = enabled
P78 Interface back-lighting switching on	0 ÷ 2	0	0 = standard; 1 = LCD always on 2 = LCD and keys always on
From P80 to P92 see "System check"			

Tab. 19 List of parameters - III

Parameter	Settable values	Default values	Notes
P18 - TSP18 Solar plant selection (only with P17=2)	0 ÷ 1	0 1 (KRBS)	0 = solar valve; 1 = solar pump
P19 - TSP19 Water heater set-point setting	10 ÷ 90 °C	60 °C	only with P18 = 1
P20 - TSP20 ΔT ON (diff. for solar pump switch-on)	1 ÷ 30 °C	6 °C	
P21 - TSP21 ΔT OFF (diff. for solar pump shut-down)	1 ÷ 30 °C	3 °C	
P22 - TSP22 Maximum collector temperature	80 ÷ 140 °C	120 °C	
P23 - TSP23 Minimum collector temperature	0 ÷ 95 °C	25 °C	
P24 - TSP24 Solar collector freeze protection	0 ÷ 1	0	0 = freeze protection inactive; 1 = freeze-protection active (only with P18 = 1)
P25 - TSP25 Solar load forcing	0 ÷ 1	0	0 = automatic operation; 1 = always active
P26 - TSP26 Enabling of water heater cooling	0 ÷ 1	0	0 = disabled; 1 = enabled (with P18 = 1 only)

Tab. 20 Solar parameter (with P17=2 or with supplementary board)

Parameter	Settable values	Default values	Notes
P80 Multifunction relay forcing	0 ÷ 1	0	0 = standard function; 1 = relay energised
P81 Zone 2 pump relay forcing	0 ÷ 1	0	0 = standard function; 1 = relay energised
P82 Zone 2 mixing valve forcing	0 ÷ 2	0	0 = standard function; 1 = force opening; 2 = force closing
P84 Zone 3 pump relay forcing	0 ÷ 1	0	0 = standard function; 1 = relay energised
P85 Zone 3 mixing valve forcing	0 ÷ 2	0	0 = standard function; 1 = force opening; 2 = force closing
P87 Zone 4 pump relay forcing	0 ÷ 1	0	0 = standard function; 1 = relay energised
P88 Zone 4 mixing valve forcing	0 ÷ 2	0	0 = standard function; 1 = force opening; 2 = force closing
P90 Solar card pump relay forcing	0 ÷ 1	0	0 = standard function; 1 = relay energised
P91 Solar board valve relay forcing - opening	0 ÷ 1	0	0 = standard function; 1 = relay energised, solar valve opens on solar water heater
P92 Solar valve / solar water heater relay forcing	0 ÷ 1	0	0 = standard function; 1 = relay energised, solar valve opens on thermal discharge

Tab. 21 System check

Parameter	Settable values	Default values	Notes
P30 External temperature	-	-	only with external probe connected
P31 Flow temperature	-	-	-
P32 Nominal calculated flow temperature	-	-	only with external probe connected
P33 Set point of zone 2 flow temperature	-	-	in V versions
P34 Current zone 2 flow temperature	-	-	in V versions
P36 Set point of zone 3 flow temperature	-	-	in Z versions
P37 Current zone 3 flow temperature	-	-	in Z versions
P39 Set point of zone 4 flow temperature	-	-	only with three zone boards connected (optional)
P40 Current zone 4 flow temperature	-	-	only with three zone boards connected (optional)
P43 Boiler return temperature	-	-	-
P44 Water heater temperature, upper part	-	-	-
P45 Flue gas temperature	-	-	-
P46 Solar collector temperature	-	-	only with solar collector probe connected
P47 Solar water heater temperature, low part	-	-	-
P48 Temperature of solar valve from solar board	-	-	standard in M versions
P49 Ambient probe SA1 temperature	-	-	only with connected ambient probe
P50 Ambient probe SA2 temperature	-	-	only with connected ambient probe

Tab. 22 Display only

3.14 Filling the system

Once all boiler connections have been completed, CH system circuit and solar system can be filled.

3.14.1 Filling the heating system

The procedure is to be cautiously carried out, following each step:

- Open the bleeding valves on all radiators and verify the boiler automatic valve operation.
- Gradually open the relevant filler cock, checking any automatic bleeding valves installed in the system properly work (see Fig. 3 Filler cock).
- Close all radiator bleeding valves as soon as water starts coming out.
- Check on boiler display that water pressure reaches the $1 \div 1.3$ bar reading.
- Shut the filler cock and bleed any air out again, by opening the air bleeding valves on radiators.
- Start the boiler and bring the system to working temperature, stop the pump, and repeat air bleeding procedure.
- Allow the system to cool and restore water pressure to $1 \div 1.3$ bars.



WARNING

Pressure sensor will not electrically enable the burner ignition when water pressure is below 0.4 bar (this parameter can be edited by qualified professional staff).

The CH system water pressure must not be lower than 1 bar. Restore proper value as needed, via the filler cock which is provided as standard with the boiler (see Fig. 3 Filler cock).

The procedure is to be followed while the system is cold.

Digital pressure gauge is used to read pressure inside the heating circuit.



WARNING

As for water treating in the domestic heating systems in order to optimise efficiency and safety, ensure a long life, trouble-free operation of auxiliary equipment, minimise power consumption, thereby integrating the standards and rules in force in the country of installation, it is recommended to use specific products suitable for multi-metal heating systems.

3.14.2 Filling the solar plant

The solar plant should be filled when the collectors are cold, in the morning or in the evening. If this is not possible, cover the collectors with sheets that do not let the sun rays through.

Keep in mind that the suggested solar plant pressure, in case of a classic installation with two collectors and a total surface of approximately 5 sq. m is of 3.5 bar approximately. In different systems, the filling pressure depends on the characteristics of the system. The solar expansion vessel filling pressure should be the same as the system pressure.

To fill the solar plant, proceed as follows:

- Open the two ball valves on solar circuit flow and return (see Fig. 8 Key components).
- Interrupt the flow into the system by closing valve (V). To do so, use a flat screwdriver and bring the slot on the screw to a horizontal position.
- After opening cocks (A) and (B), always using a flat blade screwdriver, feed heat transfer fluid through cock (A), using the relative pump suitable for filling solar plants, and let it exit through cock (B) until fully bleeding any air from inside the system.
- Slowly close the two cocks (A) and (B), so as to bring the pressure of the solar plant to the system-specific value.
- Re-open the flow of liquid into the system, by slowly turning valve (V), until the top part of float G indicates the desired flow value. It is recommended to set a flow value of approx. 30 l/h for every sq. m of installed solar collector (for example, two panels having an overall surface of 5 sq. m correspond to a recommended value of 150 l/h).

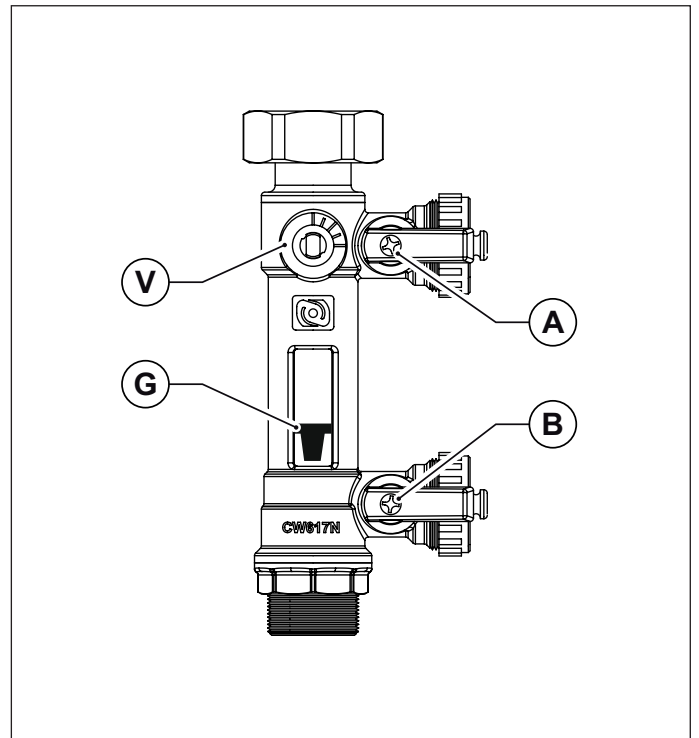

Fig. 20 Filling the solar plant

3.15 Starting up the boiler

3.15.1 Preliminary checks

Before starting the boiler, check that:

- the flue gas venting duct and the relative terminal are installed in conformity with the instructions: when the boiler is working there must be no leakage of combustion by-products from any of the gaskets;
- the supply power to the boiler must be 230 V ~ 50 Hz;
- the system is correctly filled with water (stream gauge reading 1 to 1.3 bar);
- any shut-off cocks in the system pipes are open;
- the mains gas type is correct for the boiler calibration: convert the boiler to the available gas if necessary (see *Adaptation to other gas types and burner adjustment* on page 81): have this operation carried out by qualified technical personnel;
- the gas supply cock is open;
- there are no gas leaks;
- the main switch installed ahead of the boiler is turned on;
- boiler safety valves are not stuck;
- there are no water leaks;
- the condensate trap installed on the boiler is discharging condensate correctly and is not stuck.

3.15.2 Switching on and switching off

To switch the boiler on and off, refer to the **"Instructions for the User"** (see *Instructions for the user* on page 10).

3.16 Available head

Boiler circulation pump

The boiler is equipped with a high-efficiency circulation pump with variable speed.

Circulation pump speed is automatically managed by the electronics, according to the settings of boiler parameters.

It is possible to choose between two pump working modes:

1 1 "Constant ΔT " operation

In the constant ΔT operating mode, circulation pump speed changes automatically to keep system delivery and return ΔT fixed at a value set in the boiler "super technical" parameters.

2 2 "Fixed speed" operation

In the fixed speed operating mode, circulation pump speed remains constant at the value set in the boiler "super technical" parameters.

During DHW phase, circulation pump works at a fixed speed set in the boiler parameters.



WARNING

Circulation pump is set to constant ΔT operating mode during production.

For a correct operation of the boiler, it is recommended not to change factory setting.

Should it be necessary to change circulation pump settings, contact a Service Centre.

Zone circulation pumps (KRBS-V-MV-Z-MZ)

The boiler is equipped with a high-efficiency circulation pump with variable speed.

It is possible to choose between two pump working modes:

1 "Variable head" operation

Turn circulation pump selector switch on the left side, to select variable head operating mode.

Selector switch position sets the desired maximum head.

In the variable head operating mode, circulation pump speed automatically changes when system flow resistance varies, keeping head between the value set with the selector switch and half the set value (in accordance with circulation pump work field).

2 2 "Fixed speed" operation (Min.- I - II - III)

Turn selector switch to the right, to select fixed speed operating mode.

Selector switch position sets the desired speed.

"Min." position indicates the minimum speed that can be set, "III" position indicates the maximum speed that can be set.

In fixed speed operating mode, circulation pump speed remains constant when system flow resistance varies (in accordance with circulation pump work field).



WARNING

Circulation pump is set to fixed speed (speed III) operating mode during production.

For a correct operation of the boiler, it is recommended not to change factory setting.

Should it be necessary to change circulation pump settings, contact a Service Centre.

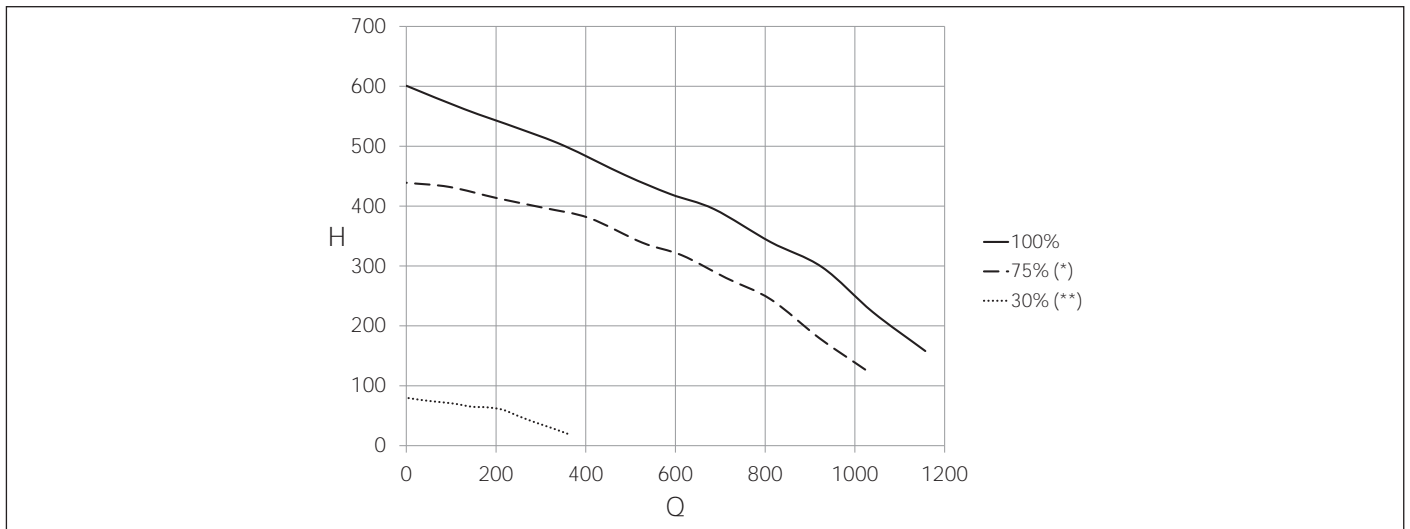

Fig. 21 Available head KRBS 12 - KRBS 24

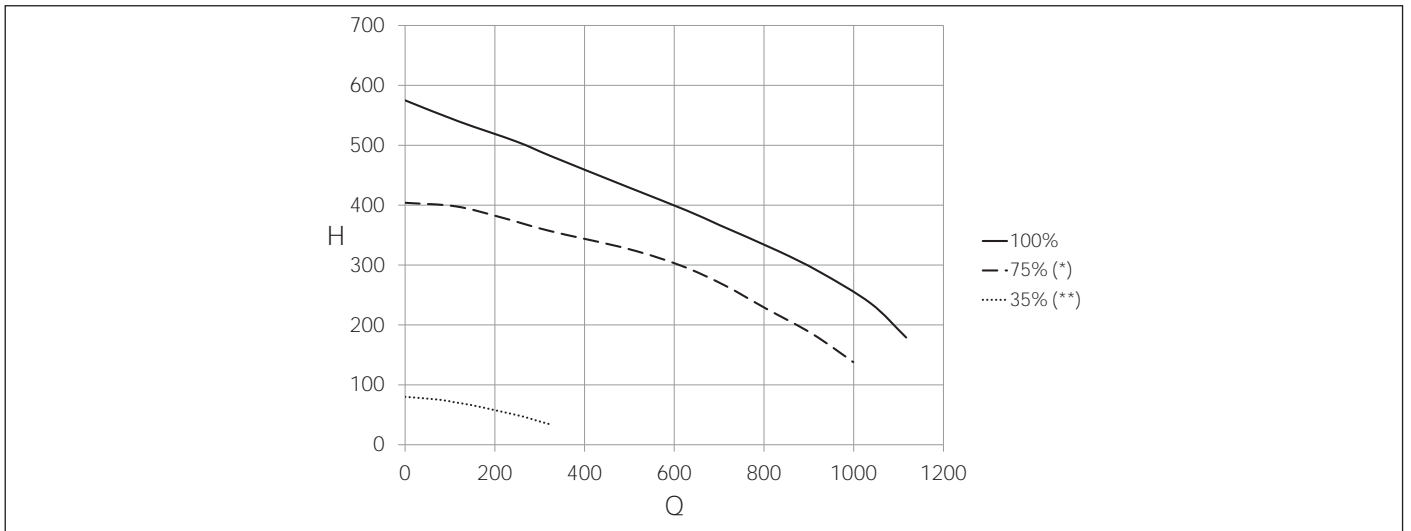

Fig. 22 Available head KRBS 28

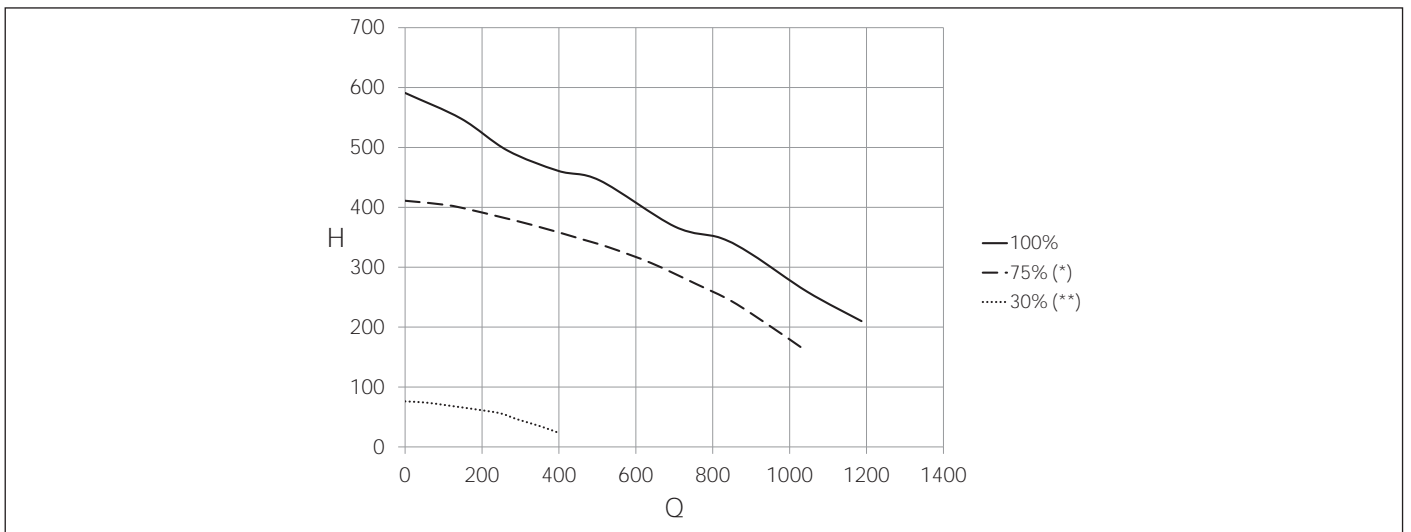

Fig. 23 Available head KRBS 32

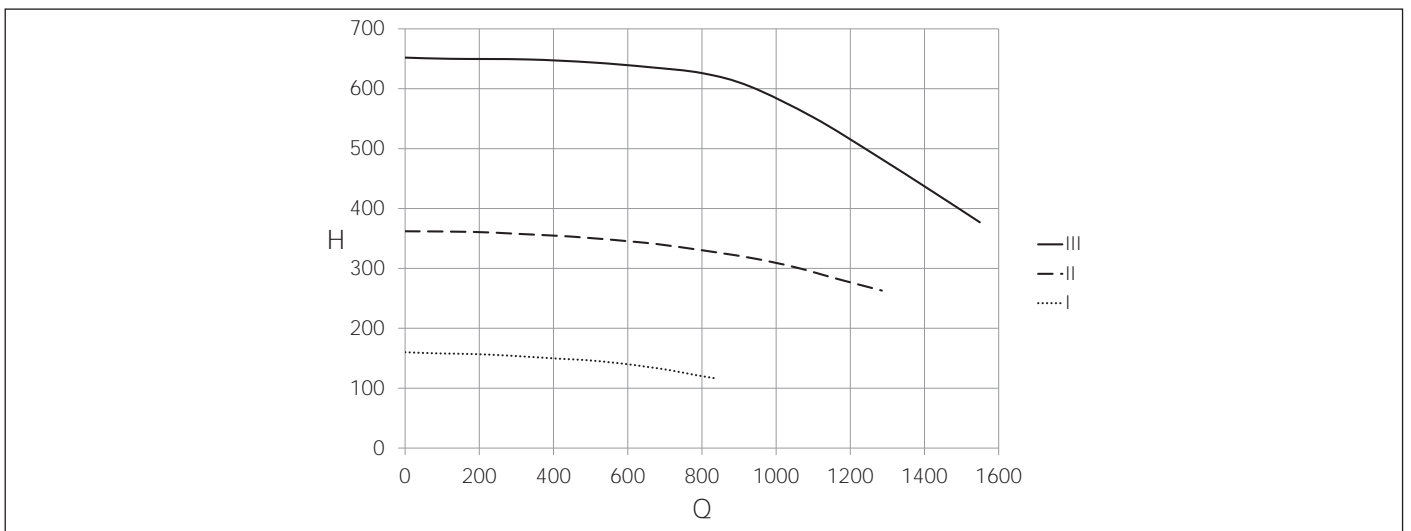

Fig. 24 Available head KRBS-V-MV-Z-MZ high temperature zone

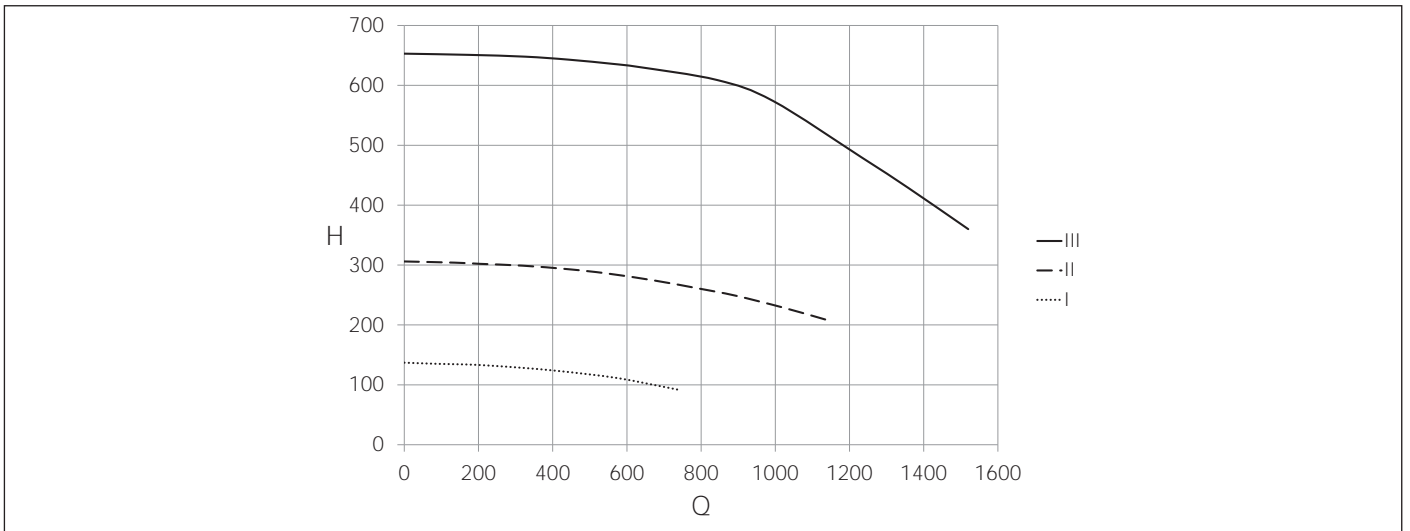

Fig. 25 Available head KRBS-V-MV-Z-MZ low temperature zone 1

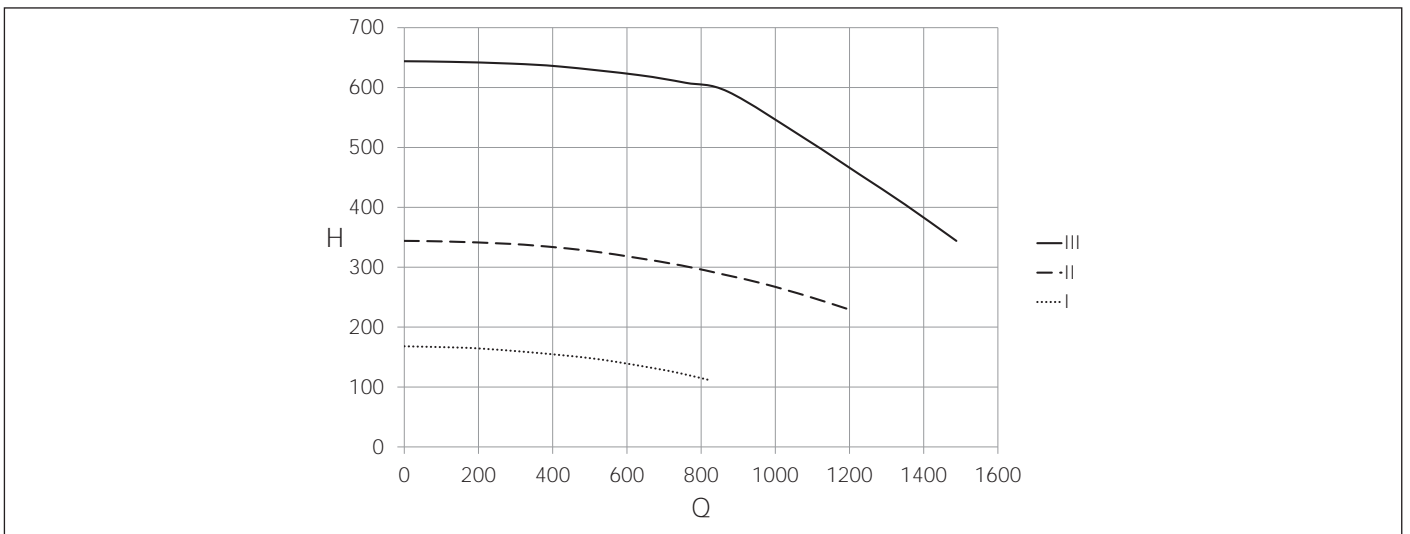

Fig. 26 Available head KRBS-Z-MZ low temperature zone 2

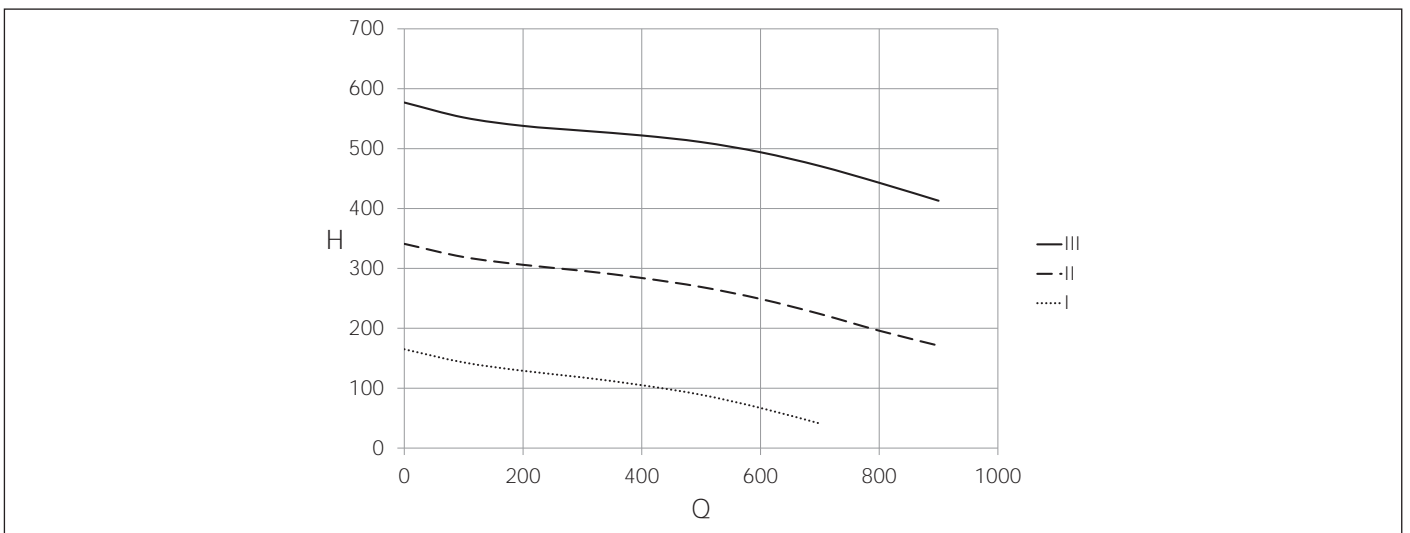

Fig. 27 Available head solar circulation pump

Q.....Flow rate (l/h)

H.....Available head (mbar)

(*) Minimum curve that can be used in systems without hydraulic separator

(**) Minimum curve that can be used in systems with hydraulic separator

3.17 Wiring diagrams

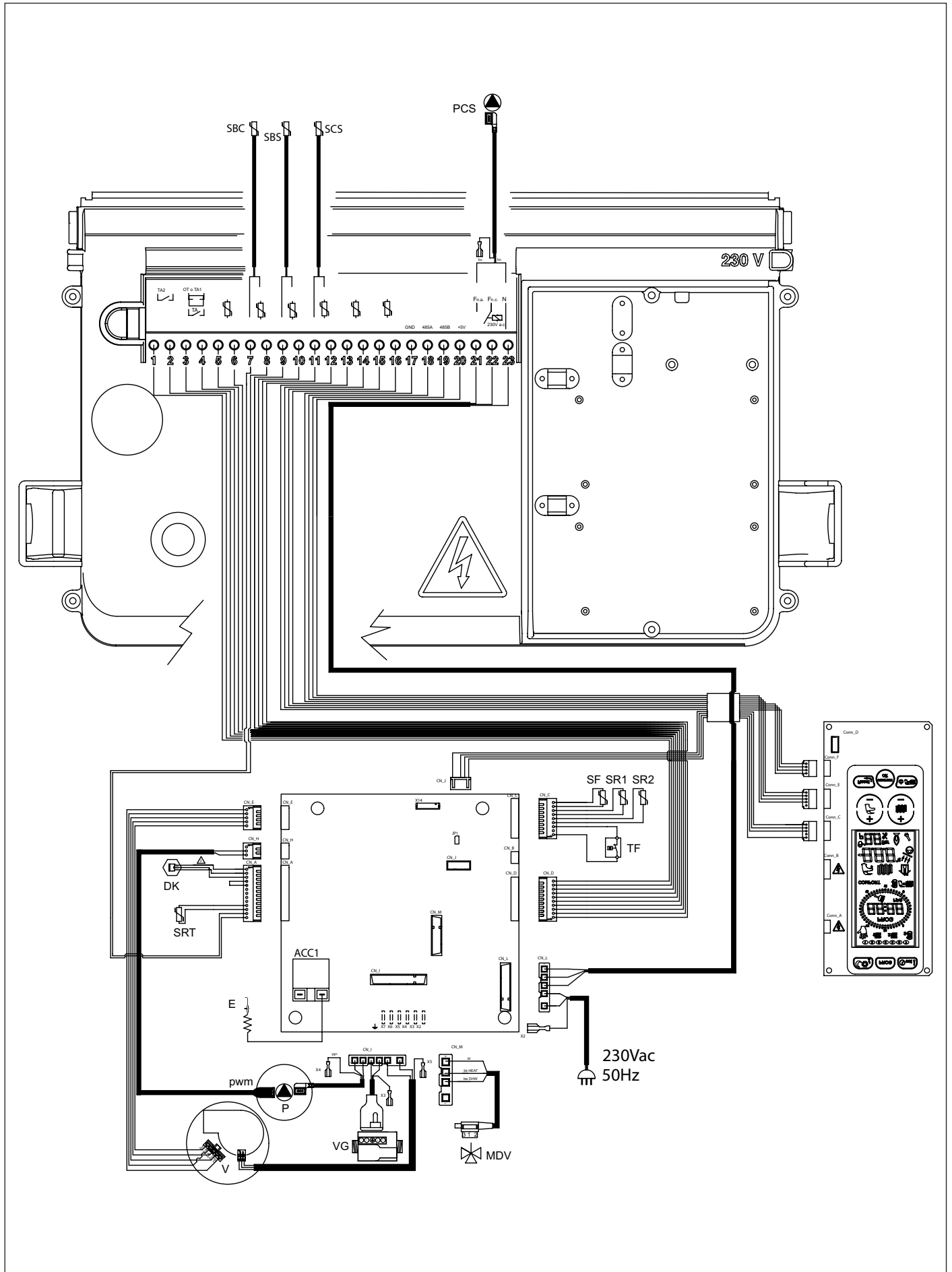

Fig. 28 Wiring diagram KRBS

Internal connections

DK:.....pressure transducer
SR1-SR2:CH NTC temperature probe 10k Ohm a 25°C B=3435
SBC:boiler water heater probe (10K Ohm B=3435)
SRT:return NTC probe 10k Ohm at 25 °C B=3435
SF:flue gas NTC probe 10k Ohm a 25°C B=2435
VG:gas valve
PCS:solar circulation pump
SBS:solar water heater probe (PT1000)
SCS:solar collector probe (PT1000)
E:ignition/flame detection electrode
V:brushless fan
TF:flue gas thermostat
P:boiler pump
PWM:PMW signal cable for circulation pump
MDV:electric deviating valve
ACC1:ignition transformer
X2-X7:ground connectors

Connections performed by the installer

1-2:TA2 - Ambient thermostat 2
3-4:OT or TA1 - Remote Control or ambient thermostat
5-6:external probe (10K Ohm B=3977 at 25° C)
11-12:solar collector probe (PT1000)
13-14:ambient probe 1
15-16:ambient probe 2
17-18-19-20:485 port for connection of additional boards
17:GND
18:A
19:B
20:+5V

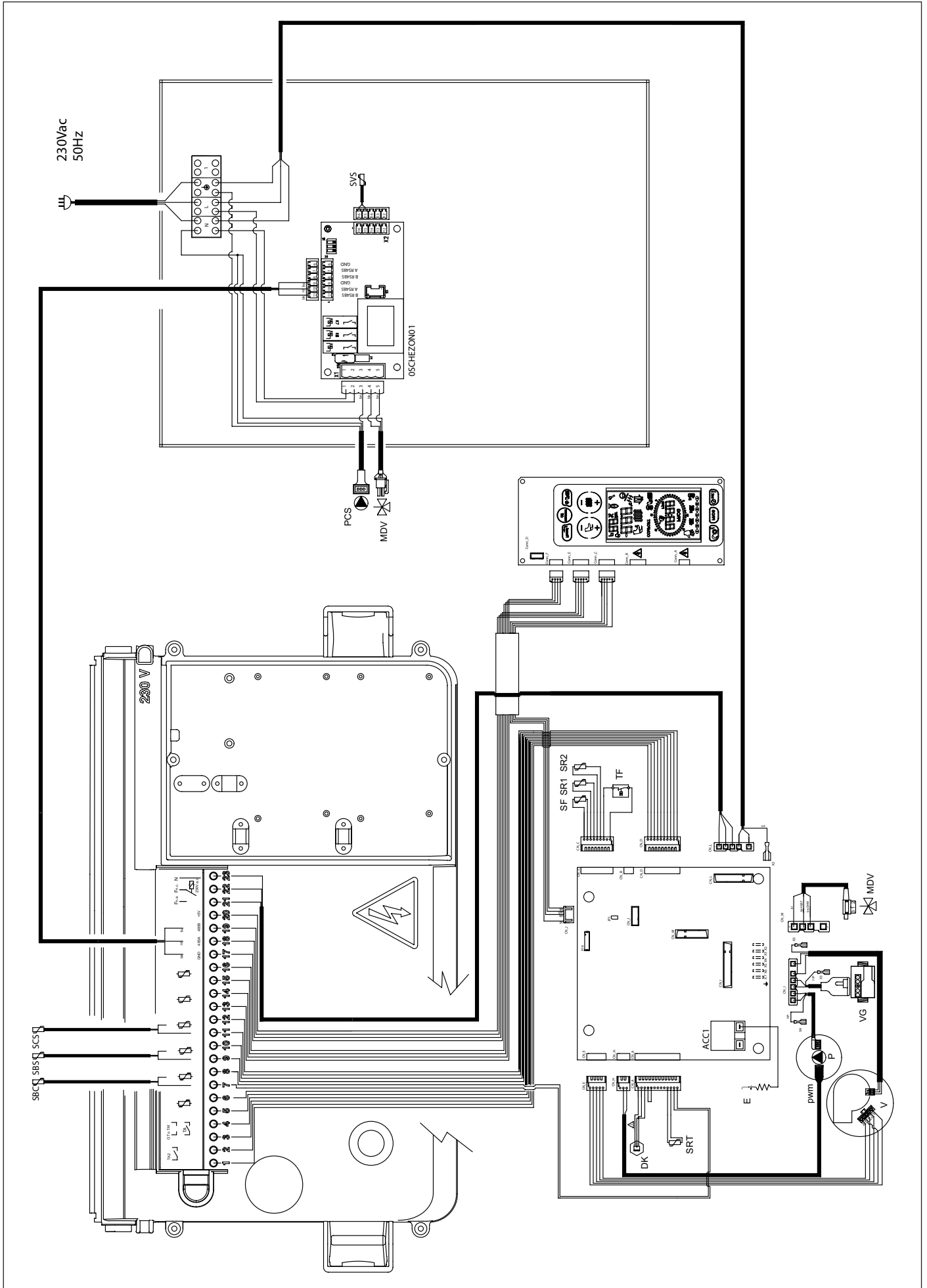

Fig. 29 Wiring diagram KRBS-M

Internal connections

DK:.....pressure transducer
SR1-SR2:CH NTC temperature probe 10k Ohm a 25°C B=3435
SBC:boiler water heater probe (10K Ohm B=3435)
SRT:return NTC probe 10k Ohm at 25 °C B=3435
SF:flue gas NTC probe 10k Ohm a 25°C B=2435
VG:gas valve
PCS:solar circulation pump
SBS:solar water heater probe (PT1000)
SCS:solar collector probe (PT1000)
E:ignition/flame detection electrode
V:brushless fan
TF:flue gas thermostat
P:boiler pump
PWM:PMW signal cable for circulation pump
MDV:electric deviating valve
SVS:solar valve probe
ACC1:ignition transformer
X2-X7:ground connectors
OSCHEZON01:thermal discharge management board

Connections performed by the installer

1-2:TA2 - Ambient thermostat 2
3-4:OT or TA1 - Remote Control or ambient thermostat
5-6:external probe (10K Ohm B=3977 at 25° C)
11-12:solar collector probe (PT1000)
13-14:ambient probe 1
15-16:ambient probe 2
21-22-23:Programmable relay
 21:phase (NO)
 22:phase (NC)
 23:neutral (COMMON)

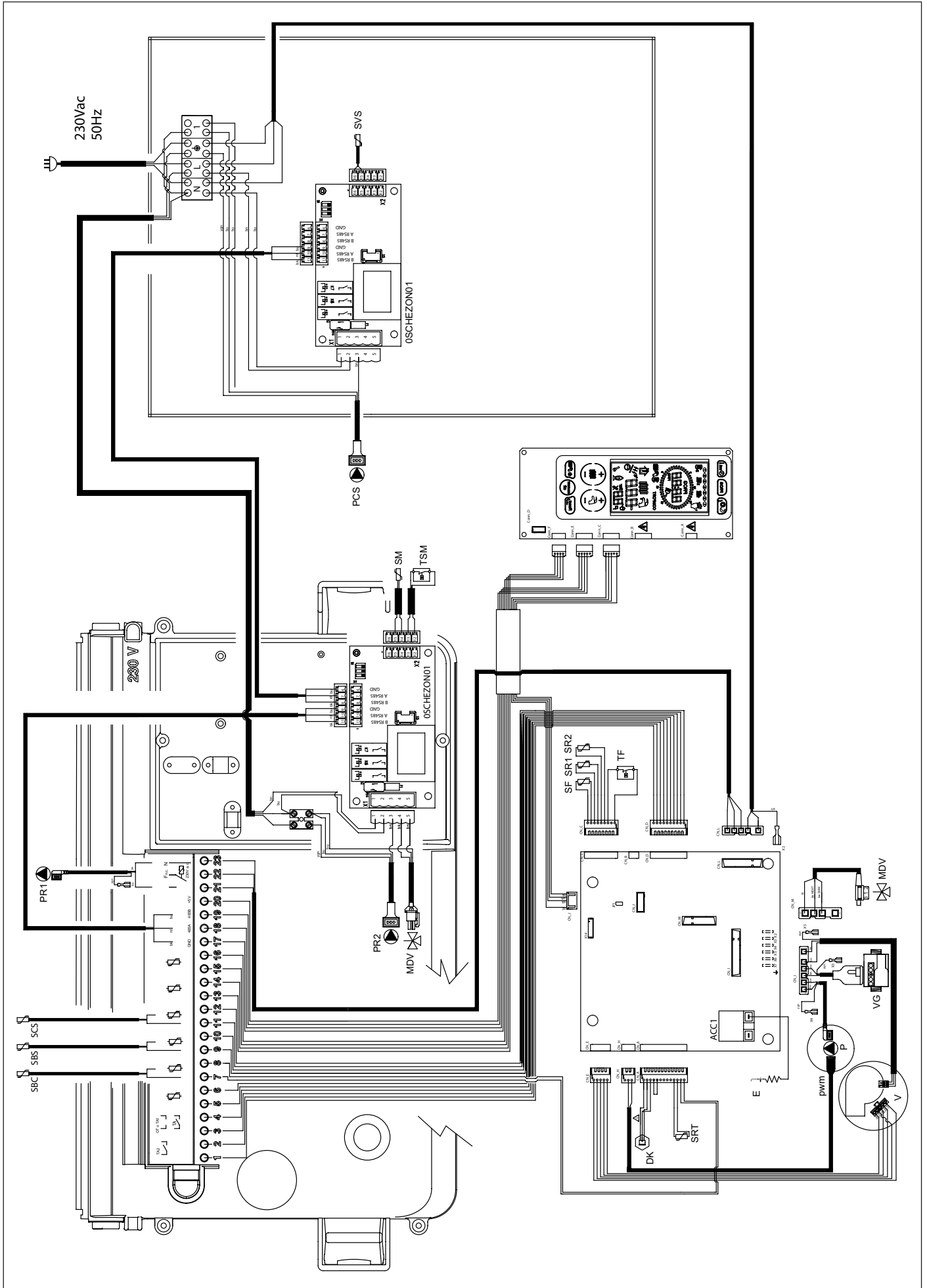

Fig. 30 Wiring diagram KRBS-V

Internal connections

DK:.....pressure transducer
SR1-SR2:CH NTC temperature probe 10k Ohm a 25°C B=3435
SBC:boiler water heater probe (10K Ohm B=3435)
SRT:return NTC probe 10k Ohm at 25 °C B=3435
SF:flue gas NTC probe 10k Ohm a 25°C B=2435
VG:gas valve
PCS:solar circulation pump
SBS:solar water heater probe (PT1000)
SCS:solar collector probe (PT1000)
E:ignition/flame detection electrode
V:brushless fan
TF:flue gas thermostat
P:boiler pump
PWM:PMW signal cable for circulation pump
PR1:zone 1 circulation pump
PR2:zone 2 circulation pump
MDV:electric deviating valve
TSM:mixed zone flow safety thermostat
SM:flow NTC probe for mixed zone 10k Ohm at 25°C B=3435
ACC1:ignition transformer
X2-X7:ground connectors
OSCHEZON01:zone management board

Connections performed by the installer

1-2:TA2 - Ambient thermostat 2
3-4:OT or TA1 - Remote Control or ambient thermostat
5-6:external probe (10K Ohm B=3977 at 25° C)
11-12:solar collector probe (PT1000)
13-14:ambient probe 1
15-16:ambient probe 2

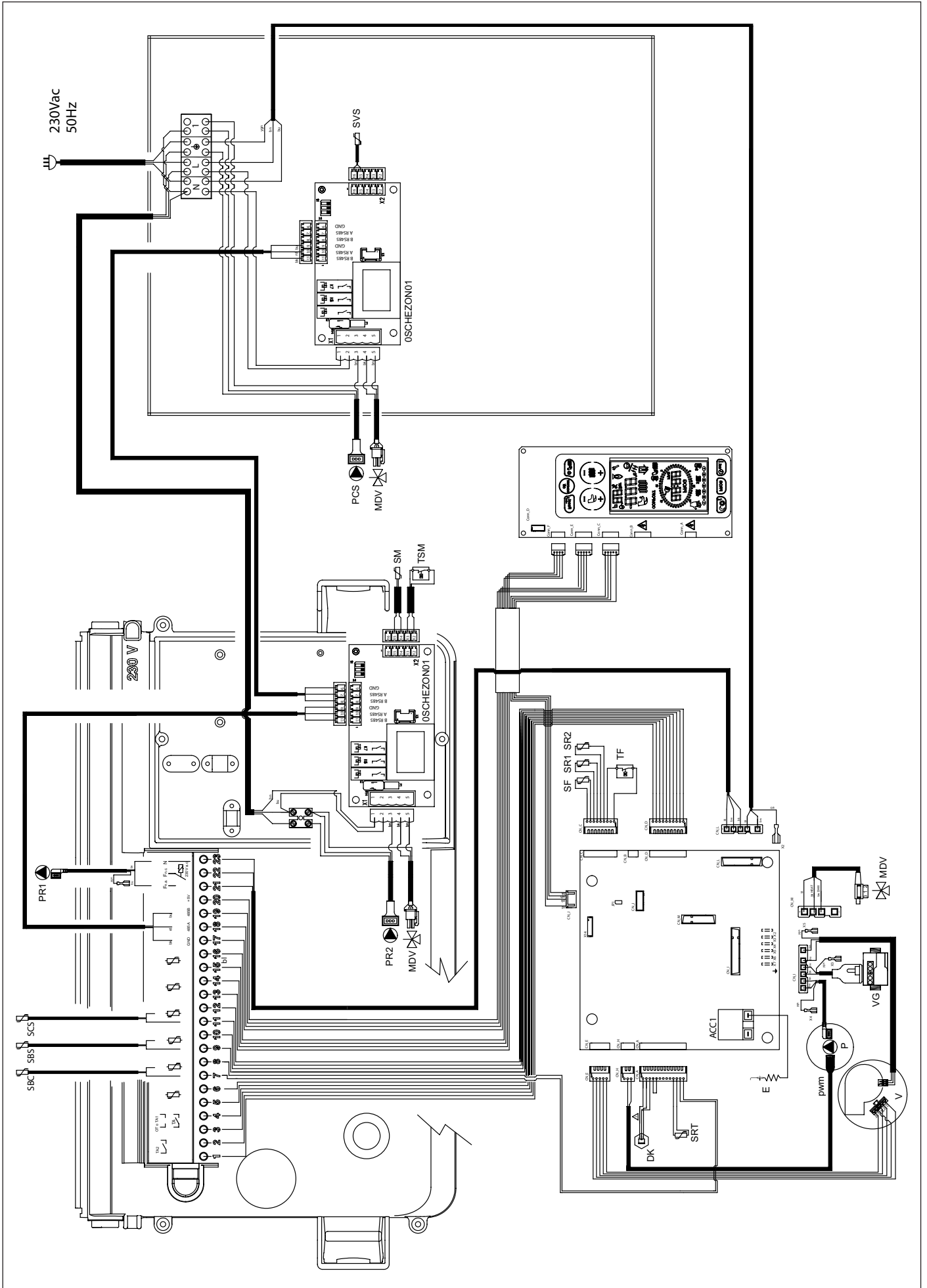

Fig. 31 Wiring diagram KRBS-MV

Internal connections

DK:.....pressure transducer
SR1-SR2:CH NTC temperature probe 10k Ohm a 25°C B=3435
SBC:boiler water heater probe (10K Ohm B=3435)
SRT:return NTC probe 10k Ohm at 25 °C B=3435
SF:flue gas NTC probe 10k Ohm a 25°C B=2435
VG:gas valve
PCS:solar circulation pump
SBS:solar water heater probe (PT1000)
SCS:solar collector probe (PT1000)
E:ignition/flame detection electrode
V:brushless fan
TF:flue gas thermostat
P:boiler pump
PWM:PMW signal cable for circulation pump
PR1:zone 1 circulation pump
PR2:zone 2 circulation pump
MDV:electric deviating valve
TSM:mixed zone flow safety thermostat
SM:flow NTC probe for mixed zone 10k Ohm at 25°C B=3435
SVS:solar valve probe
ACC1:ignition transformer
X2-X7:ground connectors
OSCHEZON01:thermal discharge management board/zone management board

Connections performed by the installer

1-2:TA2 - Ambient thermostat 2
3-4:OT or TA1 - Remote Control or ambient thermostat
5-6:external probe (10K Ohm B=3977 at 25° C)
11-12:solar collector probe (PT1000)
13-14:ambient probe 1
15-16:ambient probe 2

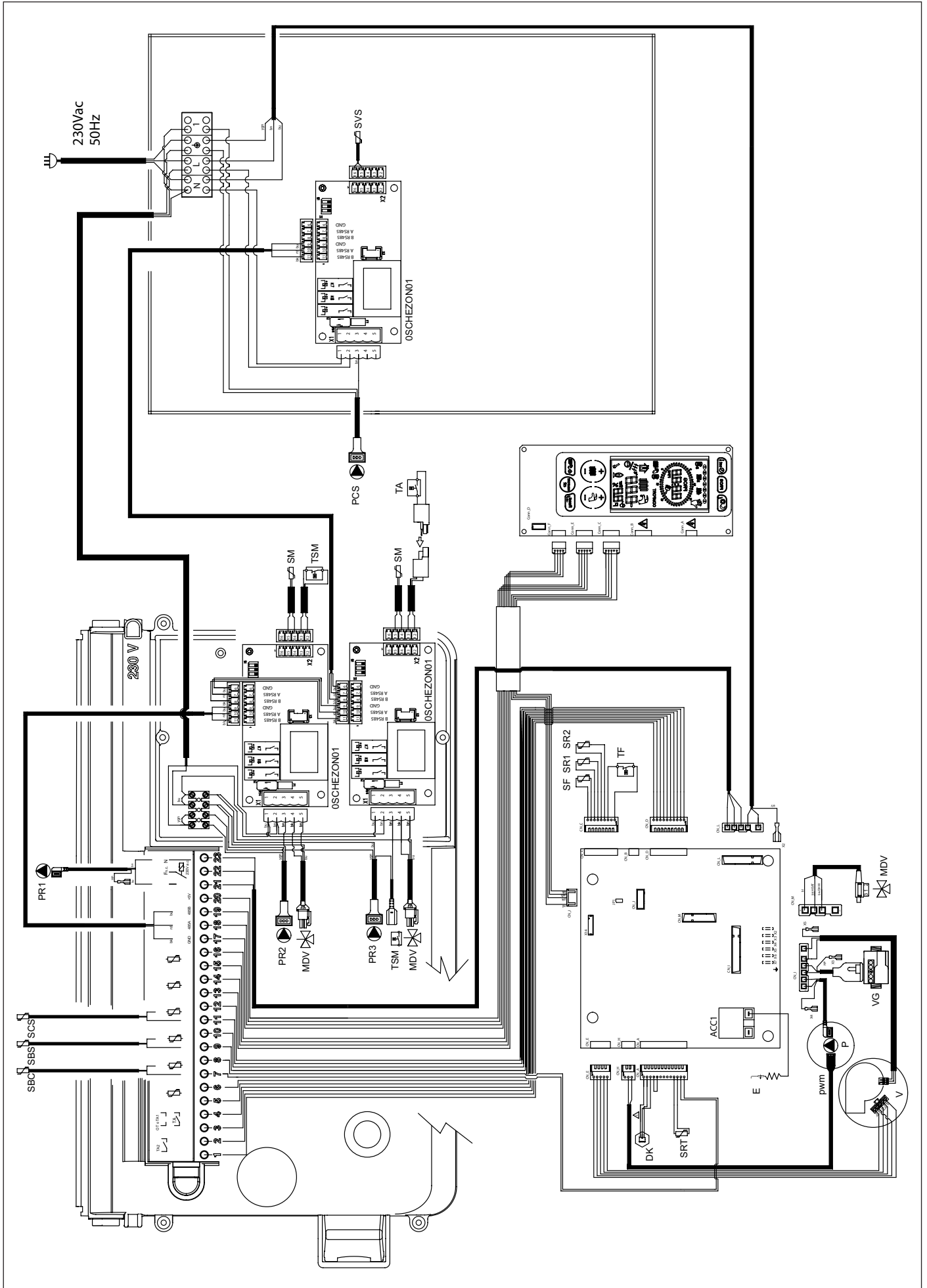

Fig. 32 Wiring diagram KRBS-Z

Internal connections

DK:.....pressure transducer
SR1-SR2:CH NTC temperature probe 10k Ohm a 25°C B=3435
SBC:boiler water heater probe (10K Ohm B=3435)
SRT:return NTC probe 10k Ohm at 25 °C B=3435
SF:flue gas NTC probe 10k Ohm a 25°C B=2435
VG:gas valve
PCS:solar circulation pump
SBS:solar water heater probe (PT1000)
SCS:solar collector probe (PT1000)
E:ignition/flame detection electrode
V:brushless fan
TF:flue gas thermostat
P:boiler pump
PWM:PMW signal cable for circulation pump
PR1:zone 1 circulation pump - high temperature
PR2:zone 2 circulation pump - mixed zone
PR3:zone 3 circulation pump - mixed zone
MDV:electric deviating valve
TSM:mixed zone flow safety thermostat
SM:flow NTC probe for mixed zone 10k Ohm at 25°C B=3435
ACC1:ignition transformer
X2-X7:ground connectors
OSCHEZON01:zone management board

Connections performed by the installer

1-2:TA2 - Ambient thermostat 2
3-4:OT or TA1 - Remote Control or ambient thermostat
5-6:external probe (10K Ohm B=3977 at 25° C)
11-12:solar collector probe (PT1000)
13-14:ambient probe 1
15-16:ambient probe 2
TA:TA3 - Ambient thermostat 3 (on OSCHEZON01)

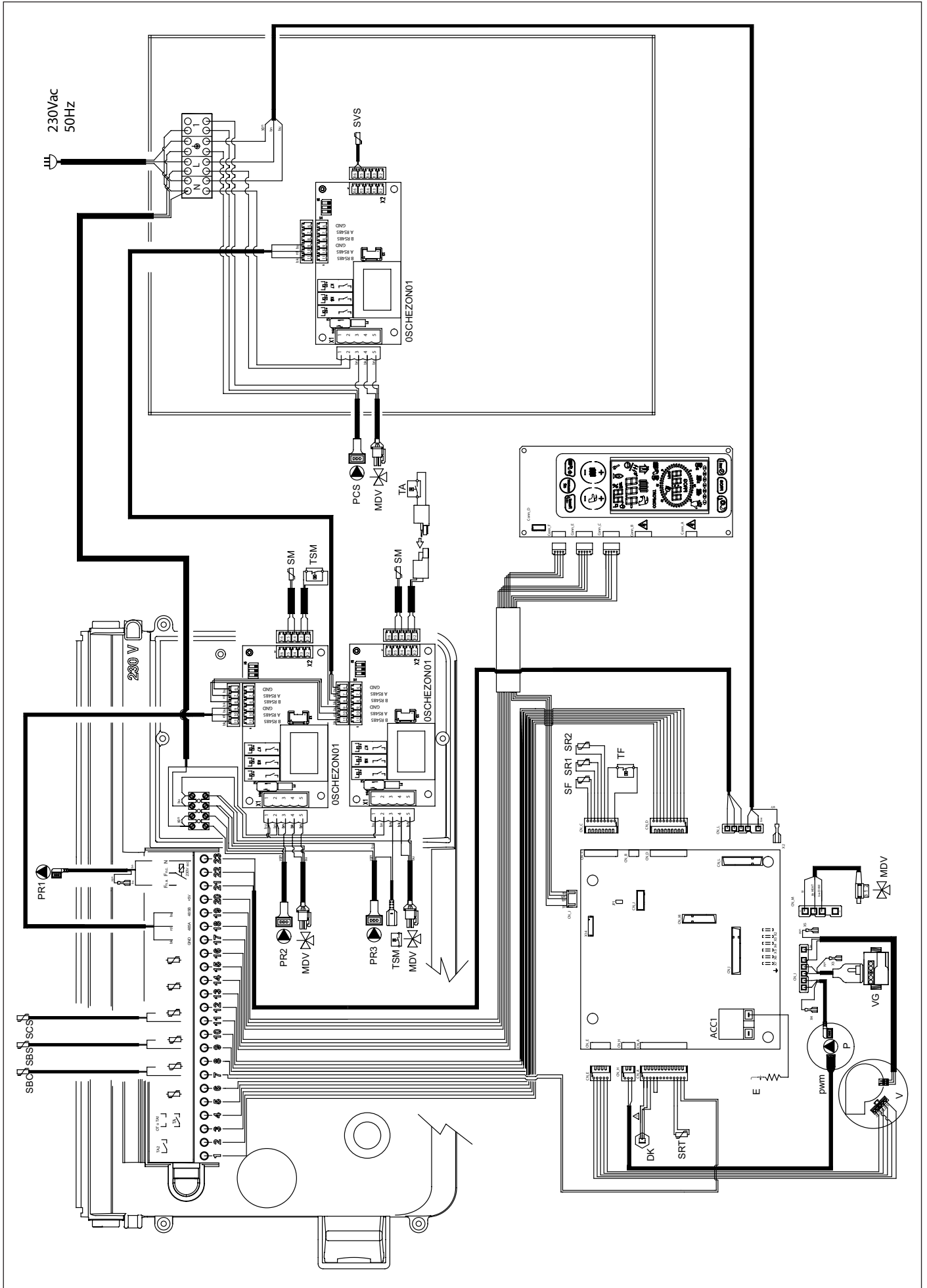

Fig. 33 Wiring diagram KRBS-MZ

Internal connections

DK:.....pressure transducer
SR1-SR2:CH NTC temperature probe 10k Ohm a 25°C B=3435
SBC:boiler water heater probe (10K Ohm B=3435)
SRT:return NTC probe 10k Ohm at 25 °C B=3435
SF:flue gas NTC probe 10k Ohm a 25°C B=2435
VG:gas valve
PCS:solar circulation pump
SBS:solar water heater probe (PT1000)
SCS:solar collector probe (PT1000)
E:ignition/flame detection electrode
V:brushless fan
TF:flue gas thermostat
P:boiler pump
PWM:PMW signal cable for circulation pump
PR1:zone 1 circulation pump - high temperature
PR2:zone 2 circulation pump - mixed zone
PR3:zone 3 circulation pump - mixed zone
MDV:electric deviating valve
TSM:mixed zone flow safety thermostat
SM:flow NTC probe for mixed zone 10k Ohm at 25°C B=3435
SVS:solar valve probe
ACC1:ignition transformer
X2-X7:ground connectors
OSCHEZON01:zone management board

Connections performed by the installer

1-2:TA2 - Ambient thermostat 2
3-4:OT or TA1 - Remote Control or ambient thermostat
5-6:external probe (10K Ohm B=3977 at 25° C)
11-12:solar collector probe (PT1000)
13-14:ambient probe 1
15-16:ambient probe 2
TA:TA3 - Ambient thermostat 3 (on OSCHEZON01)

3.17.1 Relationship between temperature and nominal resistance of all NTC probes

T (°C)	0	2	4	6	8
0	27203	24979	22959	21122	19451
10	17928	16539	15271	14113	13054
20	12084	11196	10382	9634	8948
30	8317	7736	7202	6709	6254
40	5835	5448	5090	4758	4452
50	4168	3904	3660	3433	3222
60	3026	2844	2674	2516	2369
70	2232	2104	1984	1872	1767
80	1670	1578	1492	1412	1336
90	1266	1199	1137	1079	1023

Tab. 23 Relationship between "Temperature and Nominal resistance" for temperature probes

3.18 Adaptation to other gas types and burner adjustment



WARNING

This boiler is built to run on the type of gas specified on the packaging and on the boiler rating plate.

Any later transformation is to be exclusively carried out by qualified personnel, using manufacturer designed accessories and following the procedure and adjustment instructions for an accurate boiler setting-up.

3.18.1 Switching from NATURAL GAS to PROPANE

- Disconnect the boiler from the electric power supply.
- Open the boiler casing.
- Loosen the three screws securing combustion chamber front panel to frame, then remove panel.
- Loosen the screw securing intake pipe to mixer, and remove pipe (see Fig. 34 Intake pipe).
- Disconnect the gas pipe from the mixer (see Fig. 34 Intake pipe).
- Loosen the three socket head screws, and remove the mixer (see Fig. 35 Mixer).
- Loosen the two retaining screws, and slide out mixer plastic body (see Fig. 36 Mixer plastic body).
- Using a 6 mm Allen wrench, loosen the two mixer nozzles (see Fig. 36 Mixer plastic body).
- Screw the new nozzles for propane listed in Tab. 26 Diameter of nozzles - diaphragms (mm), taking care to drive them fully home, without tightening.
- Only for 32 kW versions model, insert the 7.2 mm diaphragm on the outlet of the gas valve.



WARNING

In case the nozzle idles when reaching the bottom of the nozzle threaded seat, it means that the thread is damaged and perfect sealing is not ensured. The whole mixer shall be replaced.

- To refit the plastic body (Venturi), insert it inside mixer and secure it in place with the retaining screws. Take care not to damage the O-rings assembled on plastic body ends (see Fig. 36 Mixer plastic body) and to respect the assembling direction (see Fig. 37 Assembling direction).
- Refit the reassembled mixer onto the fan with the socket head screws, making sure to insert the O-ring between mixer and fan (see Fig. 36 Mixer plastic body).
- Reconnect boiler to electric power supply, and open the gas cock.
- Edit value for parameter **P0-TSP0** depending on boiler power (see par. *Edit parameter P0-TSP0* on page 84).
- Adjust the gas valve (see par. *Gas valve setting* on page 84).

3.18.2 Switching from PROPANE to NATURAL GAS

- Disconnect the boiler from the electric power supply.
- Open the boiler front casing.
- Loosen the three screws securing combustion chamber front panel to frame, then remove panel.
- Loosen the screw securing intake pipe to mixer, and remove pipe (see Fig. 34 Intake pipe).
- Disconnect the gas pipe from the mixer (see Fig. 34 Intake pipe).
- Loosen the three socket head screws, and remove the mixer (see Fig. 35 Mixer).
- Loosen the two retaining screws, and slide out mixer plastic body (see Fig. 36 Mixer plastic body).
- Using a 6 mm Allen wrench, loosen the two mixer nozzles (see Fig. 36 Mixer plastic body).
- Screw the new nozzles for methane listed in Tab. 26 Diameter of nozzles - diaphragms (mm), taking care to drive them fully home, without tightening.
- Only for 32 kW versions model, remove the 7.2 mm diaphragm on the outlet of the gas valve.



WARNING

In case the nozzle idles when reaching the bottom of the nozzle threaded seat, it means that the thread is damaged and perfect sealing is not ensured. The whole mixer shall be replaced.

- To refit the plastic body (Venturi), insert it inside mixer and secure it in place with the retaining screws. Take care not to damage the O-rings assembled on plastic body ends (see Fig. 36 Mixer plastic body) and to respect the assembling direction (see Fig. 37 Assembling direction).
- Refit the reassembled mixer onto the fan with the socket head screws, making sure to insert the O-ring between mixer and fan (see Fig. 36 Mixer plastic body).
- Reconnect boiler to electric power supply, and open the gas cock.
- Edit value for parameter **P0-TSP0** depending on boiler power (see par. *Edit parameter P0-TSP0* on page 84).
- Adjust the gas valve (see par. *Gas valve setting* on page 84).

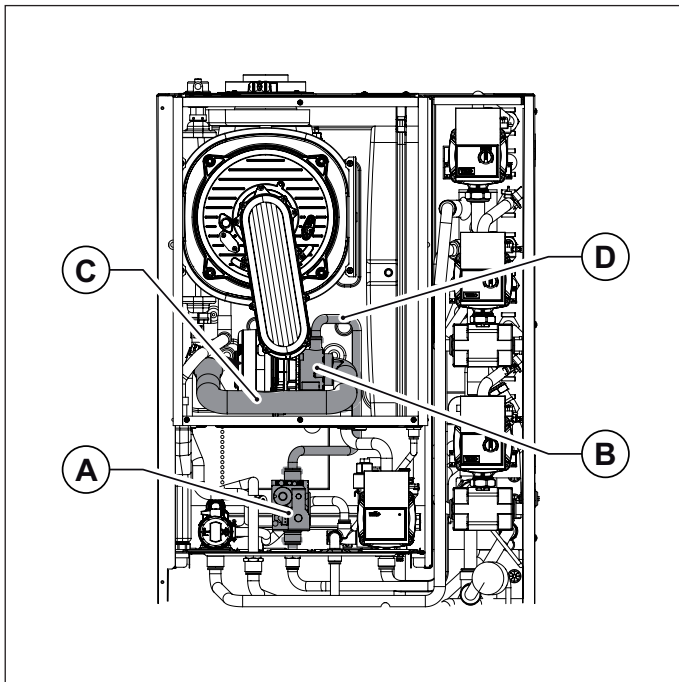

Fig. 34 Intake pipe

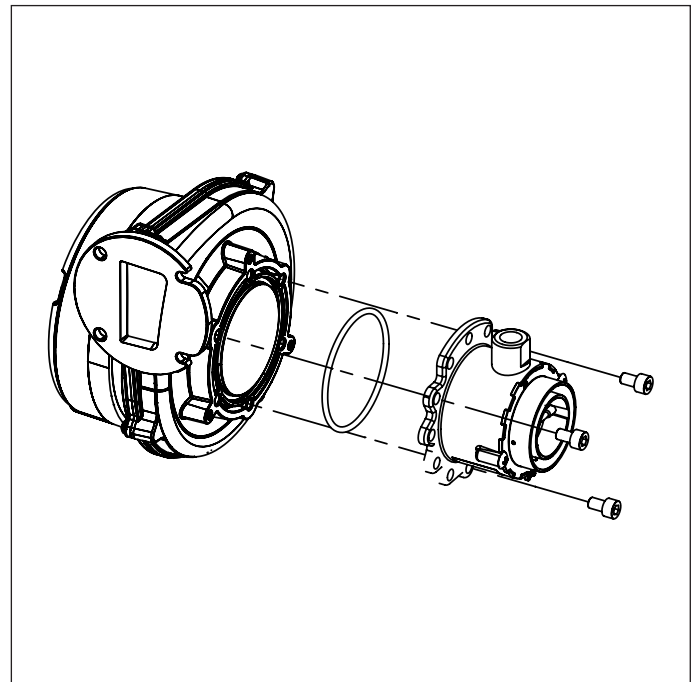

Fig. 35 Mixer

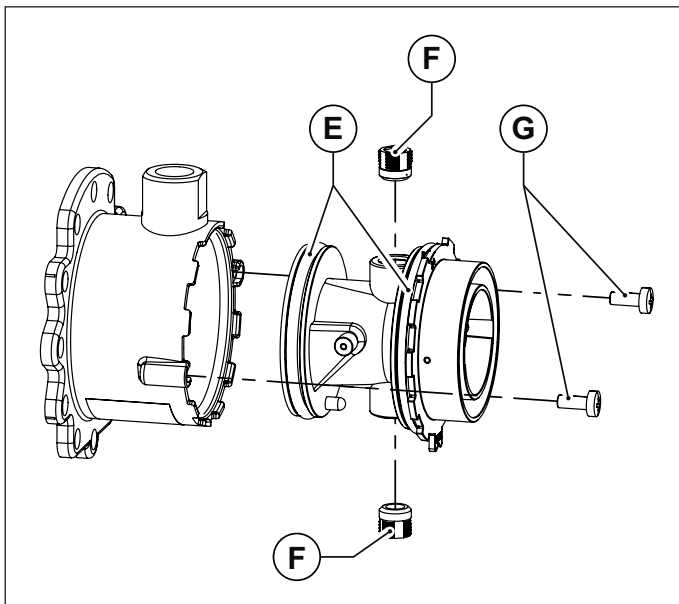

Fig. 36 Mixer plastic body

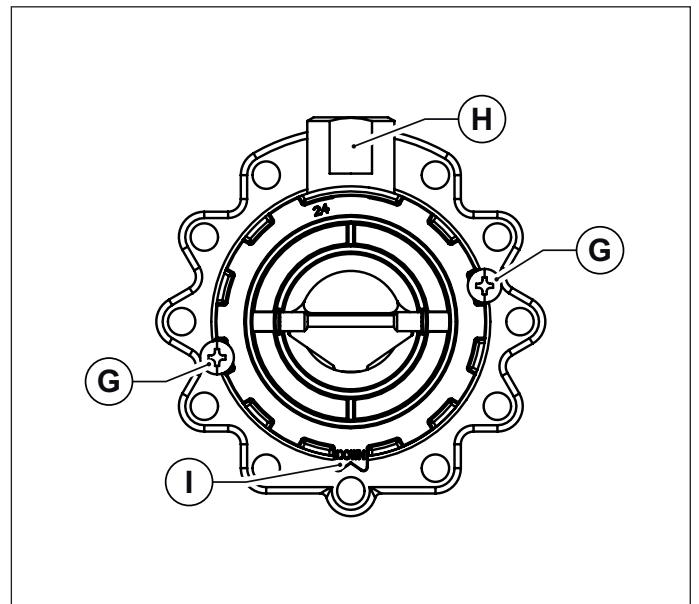

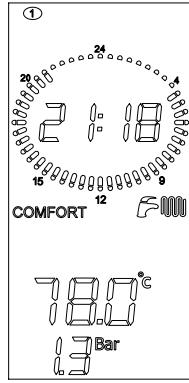

Fig. 37 Assembling direction

- A. Gas valve
- B. Mixer
- C. Air intake
- D. Gas pipe
- E. O-ring
- F. Nozzles
- G. Venturi to mixer retaining screws
- H. Gas fitting
- I. Direction tab

3.18.3 Edit parameter P0-TSP0

1. Press  and **ON** at the same time for three seconds.



2. Scroll through the parameters by pressing **CH +/-** buttons. As soon as you reach the one to be modified, press **OK**.
3. The wrench symbol turns on and indicates you can edit the parameter value.

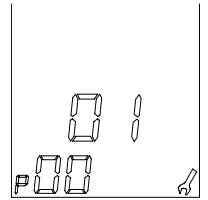

4. The parameter value can be edited using **CH +/-** buttons.
5. To confirm modification press **OK**.
6. To quit editing mode without changing the parameter press .





Boiler settings	Parameter P0-TSP0 value
12 kW Natural gas	0
12 kW Propane	5
24 kW Methane	1
24 kW Propane	3
28 kW Methane	2
28 kW Propane	4
32 kW Methane	6
32 kW Propane	7

Tab. 24 Table

7. Adjust the gas valve (see *Gas valve setting* on page 84).

3.18.4 Gas valve setting

Maximum heating output adjustment

- Make sure that the ambient thermostat (optional), if fitted, is set to **ON**.
- Select the "heating" mode on the control panel pressing key  n times until symbol  is displayed.
- Start the 'flue cleaning' function by keeping  key pressed until symbol  stops flashing. Boiler switches to max. output operation.
- If a gas switching has been made, access the programming page and set the parameter **P0** based on the power and on the gas, as specified in Tab. 16 Limits to be set for TSP parameters and default values in relation to boiler type (TSP0).
- Set flue gas CO2 content by turning the ratio adjuster **B** (see Fig. 38 Adjusting CO2 value) and ensure that reading falls within the limits of Tab. 25 Flue CO2 content. Let boiler flue cleaning function on and continue with the next point "Minimum heating output adjustment".

Minimum heating output adjustment

- Set boiler min. output operation by keeping **CH -** button pressed until the value corresponding to fan min. speed for the output and boiler gas is displayed (refer to Tab. 16 Limits to be set for TSP parameters and default values in relation to boiler type (TSP0)).
- Boiler switches to min. output operation.
- Set flue gas CO2 content by turning the offset control **C** (see Fig. 38 Adjusting CO2 value) and ensure that reading falls within the limits of Tab. 25 Flue CO2 content.
- Keep key  pressed to end the flue cleaning function.

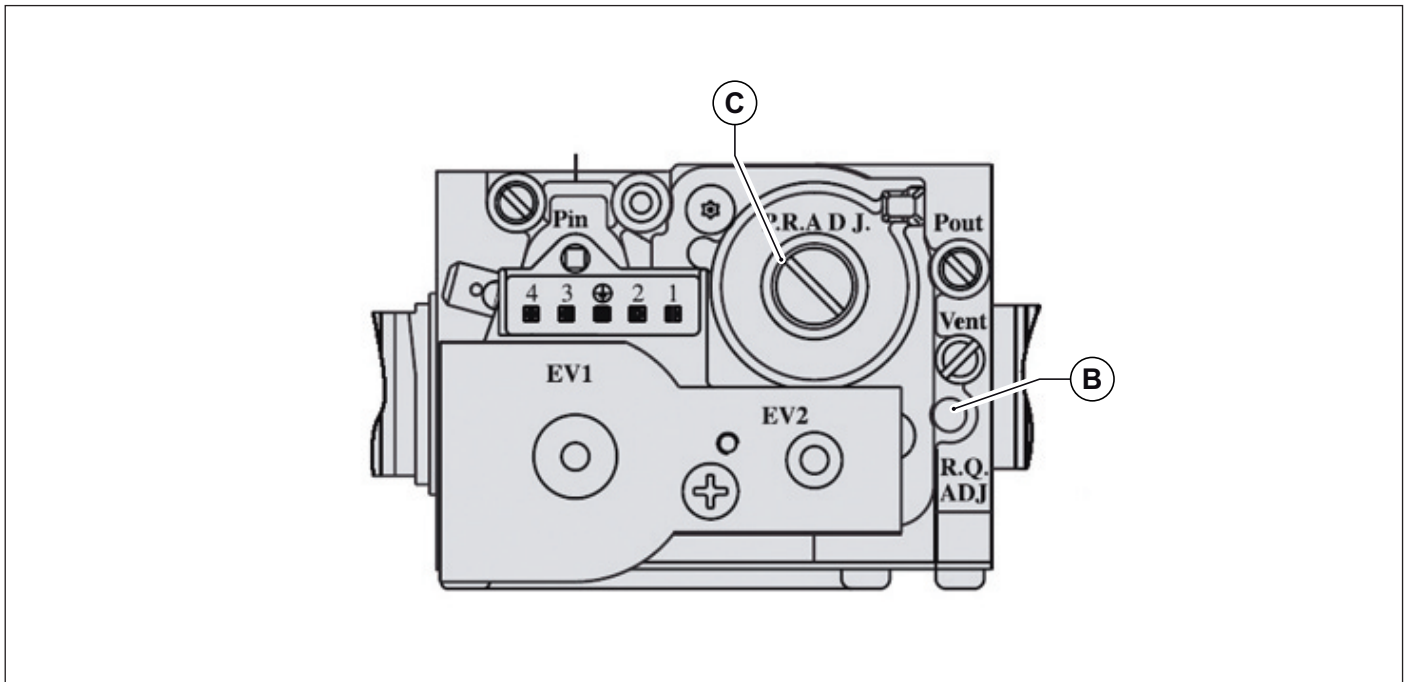

Fig. 38 Adjusting CO2 value

Fuel	CO2 value (%)
12 kW Natural gas	9.0 - 9.3
12 kW Propane	10.0 - 10.3
24 kW Methane	9.0 - 9.3
24 kW Propane	10
28 kW Methane	9.0 - 9.3
28 kW Propane	10 - 10.3
32 kW Methane	9.0 - 9.3
32 kW Propane	10

Tab. 25 Flue CO2 content

Model	Natural gas	Propane
12 kW	3.05	2.50
24 kW	3.70	3.00
28 kW	4.00	3.30
32 kW	4.45	3.55 + diaphragm Ø 7.2

Tab. 26 Diameter of nozzles - diaphragms (mm)

4. Testing the boiler

4.1 Preliminary checks

Before testing the boiler, it is recommended to check the following:

- the installation is compliant with the prevailing standards;
- the flue gas venting duct and the relative terminal are installed in conformity with the instructions: when the boiler is working there must be no leakage of combustion by-products from any of the gaskets;
- the supply power to the boiler must be 230 V ~ 50 Hz;
- the heating system is correctly filled with water (pressure gauge reading 1 to 1.3 bar);
- the solar plant is filled with the correct mix of water and glycol and the flowmeter indicates the correct fluid flow value;
- any shut-off cocks in the system pipes are open;
- the mains gas type is correct for the boiler calibration: convert the boiler to the available gas if necessary (see par. *Adaptation to other gas types and burner adjustment* on page 81); have this operation carried out by qualified technical personnel;
- the gas supply cock is open;
- there are no fuel gas leaks;
- the main switch installed ahead of the boiler is turned on;
- the safety valves of the CH and DHW circuits are not stuck;
- the solar circuit safety valve is not stuck;
- there are no water leaks;
- the condensate trap installed on the boiler is discharging condensate correctly and is not stuck.



WARNING

Should the boiler not be installed in compliance with the prevailing laws and standards, notify the system supervisor and do not test the boiler.

4.2 Switching on and switching off

To switch the boiler on and off, refer to the “**Instructions for the User**”.

5. Maintenance



WARNING

Any maintenance (and repair) work must only be carried out by qualified personnel.

The user is strongly advised to have the product serviced and repaired by a service centre or qualified personnel. Appropriate boiler maintenance ensures efficient operation, environment preservation, and safety for people, animals and objects.

The boiler must be serviced at least once every year.



WARNING

Disconnect electric power supply before starting any maintenance procedure, involving replacement of components and/or cleaning inside parts of boiler.

5.1 Maintenance schedule

Maintenance operations include check and cleaning procedures. In particular:

Inspections and checks

- check general integrity of the boiler;
- check boiler and network gas supply for leakage;
- check gas supply pressure to boiler;
- check minimum and maximum gas pressures to boiler nozzles;
- check boiler ignition sequence;
- check the condition and seal integrity of the flue gas venting pipes;
- check operation of safety thermostat installed on the flue gas hood;
- check boiler combustion parameters by flue gas analysis;
- check fan hall sensor operation;
- check integrity of safety devices of the boiler in general;
- check for water leaks and oxidised areas on the boiler's couplings;
- check efficiency of the system safety valves;
- check CH and DHW expansion vessel filling pressure;
- check water heater magnesium anode integrity;
- check correct draining of condensate from the condensate trap installed on the boiler;

Solar plant checks

- check solar plant pressure and top up fluid if necessary;
- check solar plant flow rate;
- check solar expansion vessel filling pressure.



WARNING

If a solar plant fluid top-up is required, use the same product that was used for filling. Do not dilute the original fluid with water or with other fluids for any reason, because this may significantly alter the fluid's heat exchange capability and its resistance to high and low temperatures.

The following cleaning is to be done

- Clean the general interior of the boiler.
- Clean the gas nozzles.
- Clean the air intake and flue gas venting circuits.
- Clean the heat exchanger.
- clean the condensate trap and discharge ducts.

When checking the boiler for the very first time, also verify:

- Boiler room suitability.
- Diameter and length of flue gas system ducts.
- Boiler installation in accordance to this "Installation use and maintenance" manual instructions.



WARNING

Should the boiler not operate correctly, while not posing danger to people, animals or property, notify the system supervisor both verbally and in writing.

5.2 Combustion analysis

The combustion parameters of the boiler, which have to be checked in order to determine efficiency and emissions, must be measured in compliance with applicable legislation and standards.

6. Decommissioning, disassembly and disposal



Warning

If you decide to definitively decommission the boiler, have decommissioning, disassembly and disposal procedures carried out by qualified personnel, only.

The user is not authorised to carry out such operations.

Decommissioning, disassembly and disposal operations must be performed with boiler cold and disconnected from gas and power mains.

The materials the boiler is made of can all be recycled.

Once disassembled, boiler must be disposed of in accordance with the national prevailing regulations.

7. Malfunctions, possible causes and solutions

7.1 Troubleshooting

BOILER STATUS	MALFUNCTION	PROBABLE CAUSE	USER'S TASKS	QUALIFIED PERSONNEL'S TASKS	
E01*	Burner does not ignite	Gas supply failure.	Check gas supply. Check gas supply cock or gas network safety valve intervention.		
		Gas valve is disconnected.	Contact qualified personnel	Reconnect it.	
		Gas valve is faulty.	Contact qualified personnel	Replace it.	
		The board is faulty.	Contact qualified personnel	Replace it.	
	Burner does not ignite: no spark	Ignition relay is faulty.	Contact qualified personnel	Replace the electrode.	
		Ignition transformer is faulty	Contact qualified personnel	Replace the ignition transformer.	
		Electronic board does not ignite. It is faulty.	Contact qualified personnel	Replace electronic board.	
	Burner ignites for a few seconds and goes off.	Electronic board does not detect flame: inverted phase and neutral.	Contact qualified personnel	Verify correct neutral and phase connection.	
		Detection electrode cable is interrupted.	Contact qualified personnel	Reconnect or replace wire.	
		Detection electrode is faulty.	Contact qualified personnel	Replace the electrode.	
		Electronic board does not detect flame: it is faulty.	Contact qualified personnel	Replace electronic board.	
		Ignition heat input setting is too low.	Contact qualified personnel	Increase it.	
Minimum heat input is not set correctly.		Contact qualified personnel	Check burner setting.		
E02*	Flow temperature exceeded the max. allowed value.	Circulation pump is faulty.	Contact qualified personnel	Replace it.	
		Circulation pump is seized.	Contact qualified personnel	Check pump electrical connection.	
E03*	Flue thermostat triggering.	Poor flue draught.	Contact qualified personnel	Check the chimney and ambient air suction openings.	
		Flue vent/air intake duct is obstructed.	Contact qualified personnel	Check for any duct obstruction, and eliminate.	
		Flue gas thermostat is faulty.	Contact qualified personnel	Replace it.	
E04**	CH system water pressure is low.	The system is leaking.	Check system.		
		Pressure transducer is disconnected.	Contact qualified personnel	Reconnect it.	
		Pressure transducer is faulty.	Contact qualified personnel	Replace it.	
E05**	CH probe failure	Flow probe is electrically disconnected.	Contact qualified personnel	Reconnect it.	
		Flow probe faulty.	Contact qualified personnel	Replace it.	
E07**	Flue probe failure	Flue probe is electrically disconnected.	Contact qualified personnel	Reconnect it.	

BOILER STATUS	MALFUNCTION	PROBABLE CAUSE	USER'S TASKS	QUALIFIED PERSONNEL'S TASKS
E09	System pressure is too close to the max. limit.	During manual filling, a system pressure too close to the safety valve drain value has been restored.	Contact qualified personnel	Progressively drain the system until the error symbol disappears.
E12**	Boiler water heater probe failure (top part).	Probe is disconnected.	Contact qualified personnel	Reconnect it.
		Probe is faulty.	Contact qualified personnel	Replace it.
E15**	Return probe failure.	Probe is disconnected.	Contact qualified personnel	Reconnect it.
		Probe is faulty.	Contact qualified personnel	Replace it.
E24**	Solar collector failure.	Probe is disconnected.	Contact qualified personnel	Reconnect it.
		Probe is faulty.	Contact qualified personnel	Replace it.
E27**	Solar valve probe (standard in M versions) failure.	Probe is disconnected.	Contact qualified personnel	Reconnect it.
		Probe is faulty.	Contact qualified personnel	Replace it.
E28**	Solar water heater probe failure (low part).	Probe is disconnected.	Contact qualified personnel	Reconnect it.
		Probe is faulty.	Contact qualified personnel	Replace it.
E31**	Remote Control connection failure (only shown on Remote Control display).	The Remote Control is not connected to boiler board.	Contact qualified personnel	Reconnect it.
		Remote control faulty.	Contact qualified personnel	Replace it.
		Boiler board is faulty.	Contact qualified personnel	Replace it.
E35**	Safety thermostat triggering to protect the mixed "zone 2" (on versions V, MV, Z and MZ only).	Mixer valve is faulty.	Contact qualified personnel	Replace it.
		Thermostat is disconnected.	Contact qualified personnel	Reconnect it.
		Thermostat is faulty	Contact qualified personnel	Replace it.
E36**	Flow probe fault in one of the installed zones (with indication of the zone number).	Probe is disconnected.	Contact qualified personnel	Reconnect it.
		Probe is faulty.	Contact qualified personnel	Replace it.
E40*	Fan failure.	Fan disconnected.	Contact qualified personnel	Reconnect it.
		Fan faulty.	Contact qualified personnel	Replace it.
E41**	No communication between board and peripheral devices (panel interface and/or zone/solar boards).	Interface display is disconnected.	Contact qualified personnel	Reconnect it.
		Zone/solar boards are disconnected.	Contact qualified personnel	Reconnect them.
		Interface display and/or zone/solar boards are faulty.	Contact qualified personnel	Replace them.

BOILER STATUS	MALFUNCTION	PROBABLE CAUSE	USER'S TASKS	QUALIFIED PERSONNEL'S TASKS
E42	Solar system setting error.	Wrong boiler board or solar board setting parameters.	Contact qualified personnel	Check that the P03 and P18 parameter set values match with those specified on the reference tables.
E43	Zone configuration error. Wrong setting of P61 parameter.	Wrong boiler board setting parameters.	Contact qualified personnel	Check that the P61 parameter set values match with those specified on the reference tables.
E44**	Ambient probe 1 failure.	Ambient probe is disconnected.	Contact qualified personnel	Reconnect it.
		Ambient probe is faulty.	Contact qualified personnel	Replace it.
E45**	Ambient probe 2 failure.	Ambient probe is disconnected.	Contact qualified personnel	Reconnect it.
		Ambient probe is faulty.	Contact qualified personnel	Replace it.
E46	Pressure transducer failure.	Pressure transducer is disconnected.	Contact qualified personnel	Reconnect it.
		Pressure transducer is faulty.	Contact qualified personnel	Replace it.
E47	External probe with connected ambient probe error.	External probe is disconnected.	Contact qualified personnel	Reconnect it.
		External probe is faulty.	Contact qualified personnel	Replace it.
E49	The interface does not work.	The interface does not communicate with the boiler board.	Contact qualified personnel	Replace it.
E80*	The ΔT between flow and return is not within the limits.	Flow and/or return probes are faulty.	Contact qualified personnel	Replace them.
		Obstructed bypass pipe	Contact qualified personnel	Remove any obstructions, or replace the pipe.
		The bypass valve is not assembled or wrongly assembled.	Contact qualified personnel	Restore bypass valve correct assembling.
		Heat exchanger primary circuit is obstructed.	Contact qualified personnel	Clean or replace the exchanger.
E86*	Flow temperature increases too quickly.	Pump is seized.	Contact qualified personnel	Unseize the pump.
		Pump is faulty.	Contact qualified personnel	Replace it.
		Air present inside heating system.	Contact qualified personnel	Bleed the air from the boiler by opening the jollies on the exchanger and pump.
E87*	Return temperature increases too quickly.	Circulation of foreign water in boiler.	Contact qualified personnel	Check that there are no other boilers or additional cascading heat sources.
		Air present inside heating system.	Contact qualified personnel	Bleed the air from the boiler by opening the jollies on the exchanger and pump.

BOILER STATUS	MALFUNCTION	PROBABLE CAUSE	USER'S TASKS	QUALIFIED PERSONNEL'S TASKS
E89***	Faulty flue temperature value.	Flue probe on heat exchanger is faulty or damaged.	Contact qualified personnel	Replace it.
E98	The max. number of resets from the boiler touch screen has been reached.	The user has reached the max. number of resettable errors from boiler control panel.	Contact qualified personnel	Power off and then on using the switch installed ahead of the boiler.
E99	The max. number of resets from the Remote Control has been reached.	The user has reached the max. number of resettable values from the Remote Control.	Contact qualified personnel	Reset boiler interface.

* errors that can be reset by the user by keeping the **RESET** button pressed

** self-resettable errors, they automatically reset as soon as the failure is fixed

*** errors that can be reset only by the Technical Service personnel

In case errors **E51, E52, E53, E73, E85, E90** and **E91** might occur, contact a qualified service centre.

MANUFACTURER'S COMPLIANCE STATEMENT

Gas Directive 2009/142/EC
Efficiency Requirements Directive 92/42/EC
Electromagnetic Compatibility Directive 2004/108/EC
Low Voltage Directive 2006/95/EC
Ecodesign Directive 2009/125/CE
Energy Labelling Directive 2010/30/CE

FONDITAL S.p.A.
having its registered office in
Via Cerreto 40 - 25079 Vobarno (BS), Italy

STATES

that the products

Giava KRB 12, Giava KRB 24, Giava KRB 28, Giava KRB 32
Madeira Solar Compact KBS 24, Madeira Solar Compact KBS 32
Madeira Solar KRBS 12, Madeira Solar KRBS 24, Madeira Solar KRBS 28,
Madeira Solar KRBS 32

are manufactured in conformity

1. With the Type described in the CE-Type Examination Certificate and in the CE-Type Examination Certificate **51CM4094/ED**
51CM4095DR/ED

following the provisions of the Directives
Gas Directive 2009/142/EC
Efficiency Requirements Directive 92/42/EC
which satisfy the essential requisites.

2. With the provisions of the **Electromagnetic Compatibility Directive 2004/108/EC.**
3. With the provisions of the **Low Voltage Directive 2006/95/EC.**
4. With the provisions of the **Ecodesign Directive 2009/125/CE.**
5. With the provisions of the **Energy Labelling Directive 2010/30/CE.**

Fondital S.p.A.

For management
Officer i/c Technical Office

Eng. Roberto Cavallini

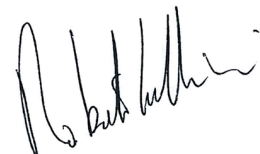

Vobarno, date of issue or of postal mark

Dichiarazione di conformità caldaie

Madeira Solar - Edizione 1 del 31 agosto 2015

Page left intentionally blank



OLIBMEEN38

Fondital S.p.A.
25079 VOBARNO (Brescia) Italy - Via Cerreto, 40
Tel. +39 0365/878.31
Fax +39 0365/878.304
e mail: info@fondital.it
www.fondital.it

The manufacturer reserves the right to modify his/her products as deemed necessary, without altering the basic characteristics of the products themselves.

Uff. Pubblicità Fondital IST 03 C 870-01 - Settembre 2015 (09/2015)