



# ITACA KB 24 - 32

INSTALLATION, USE AND MAINTENANCE



**fondital**  
BE INNOVATIVE

IST 03 C 630 - 01

EN

Dear Sirs,

Thank You for choosing and buying one of our boilers. Please read these instructions carefully in order to properly install, operate, and maintain the equipment.



**We inform users that:**

- **boilers shall be installed by an authorised company in full compliance with the prevailing standards;**
- **the installing company is required by law to issue a declaration of conformity with the current Standards concerning the performed installation;**
- **anyone entrusting installation to an unqualified installer will be subject to administrative sanctions;**
- **boilers can be maintained by authorised personnel only, under the requirements set forth by the prevailing rules.**

## General notes for installing and maintenance technicians, and users

This instruction manual is an integral and essential part of the product. It shall be supplied by the installer to the user who shall keep it carefully to consult it whenever necessary.

This document shall be supplied together with the boiler in case the latter is sold or transferred to others.



**This boiler has been manufactured to be connected to a room heating system and to a DHW distribution system. Any other use shall be considered unsuitable and dangerous for people, animals, and/or property.**

The equipment shall be installed in compliance with the prevailing standards and in accordance with the manufacturer's instructions specified in this manual: the manufacturer will not be held responsible for injuries to people and animals and/or damages to property resulting from an incorrect installation.

Damage and/or injury caused by incorrect installation or use and/or damage and/or injury due to non-observance of the manufacturer's instructions shall release the manufacturer from any and all contractual and extra-contractual liability.

Before installing the boiler, check that its technical data correspond to the requirements for its correct use in the system.

Moreover check that the boiler is intact and it has not been damaged during transport and handling. Do not install boilers which are clearly damaged and/or faulty.

Do not obstruct the air intake openings.

Only original accessories or optional kits (including the electric ones) are to be installed.

Properly dispose of the packaging as all the materials can be recycled. The packaging must therefore be sent to specific waste management sites.

The packages can be dangerous: keep them out of the reach of children.

In the event of failure and/or faulty operation, switch off the boiler. Do not attempt to make repairs: contact qualified technicians. Original parts must be used for all repairs to the boiler.

Non-observance of the above requirements may affect the safety of the boilers and endanger people, animals and/or property.



**The boiler must be serviced periodically as indicated in the relevant section of this manual. Appropriate boiler maintenance ensures efficient operation, environment preservation, and safety for people, animals and/or objects. Incorrect and irregular maintenance can be a source of danger for people, animals and property.**

The user is strongly advised to have the boiler serviced and repaired by a qualified Service Centre.

In the event of long periods of inactivity of the boiler, disconnect it from the electrical power mains and close the gas cock.

**Warning: should power mains be disconnected, boiler electronic anti-freeze function will not be operative.**

Should there be a risk of freezing, add antifreeze: it is not advisable to drain the system as this may result in damage; use specific anti-freeze products suitable for multi-metal heating systems.



**With gas fired boilers, take the following actions if you smell gas:**

- do not turn on or off electric switches and do not turn on electric appliances;
- do not ignite flames and do not smoke;
- close the main gas cock;
- open doors and windows;
- contact a Service Centre, a qualified installer or the gas supply company.

**Never use a flame to locate a gas leak.**



**The boiler is designed for installation in the countries indicated on the technical data plate: installation in any other country may be a source of danger for people, animals and/or property.**

**The manufacturer will bear no contractual and tortious liability for failure to comply with all the instructions above.**

## Rapid operating instructions

The following instructions will help you to switch the boiler on quickly and regulate it for immediate use.





**It is presumed that the boiler has been installed by a qualified installer, it has been commissioned and is ready to operate correctly.**



**If any accessories have been fitted on the boiler, these instructions will not cover them. You will therefore have to refer to the full boiler instructions as well as to the specific instructions for the accessories.**

This manual contains full details of how the boiler works, and full operating and safety instructions.

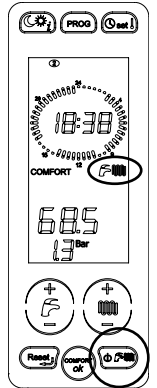

1. Open the gas cock installed ahead of the boiler.
2. Turn the master switch installed ahead of the boiler ON: the boiler display (fig. 1) turns on.

3. If you wish to activate both the heating and DHW functions, press the "operating mode selection" button  until displaying the symbol .

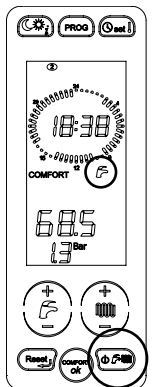

4. If you do not wish to activate the heating function, press the "operating mode selection" button  until displaying the symbol : only the DHW function will be enabled.



5. If you do not wish to activate the DHW function, press the "operating mode selection" button  until displaying the symbol : only the CH function will be enabled.

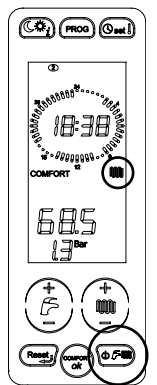

6. To set the DHW water temperature press "DHW + and -" buttons (D, fig 1).
7. Activate the water heater pressing **COMFORT** button (G, fig. 1). "COMFORT" is displayed (7, fig. 1).
8. To set the heating water temperature, press **HEATING WATER** and + and - buttons (E, fig. 1).
9. Set the desired temperature on the (optional) ambient thermostat in the building.

The boiler is now ready to operate.

If the boiler shuts down, press "**RESET**" button (F, fig. 1).

If the boiler does not resume its standard operation after three attempts, contact a qualified Service Centre.

# CONTENTS

## Warnings

<b>General notes for installers, maintenance technicians, and users .....</b>	<b>page 3</b>
<b>Rapid operating instructions.....</b>	<b>page 4</b>
<b>1. Instructions for the user.....</b>	<b>page 7</b>
1.1. Control panel.....	page 7
1.2. Interpreting BOILER STATUS from LCD DISPLAY INDICATIONS.....	page 9
1.3. "Comfort" enable/disable function.....	page 12
1.4. Selecting the operating mode.....	page 13
1.5. Adjusting heating and DHW temperature.....	page 14
1.6. Time setting.....	page 15
1.7. "Day temperature" and "night temperature" setting.....	page 16
1.8. "Manual" programme setting.....	page 17
1.9. "Automatic" programme setting.....	page 17
1.10. Programming mode for CH and water heater.....	page 18
1.11. Parameter display.....	page 19
1.12. Failures that cannot be reset.....	page 20
1.13. Resume boiler function.....	page 20
1.14. Boiler operation.....	page 21
1.14.1. Switching on.....	page 21
1.14.2. CH function.....	page 21
1.14.3. DHW function.....	page 21
1.14.4. Anti-legionella function.....	page 21
1.14.5. Freeze-protection function.....	page 22
1.14.5.1. Ambient probe freeze-protection function.....	page 22
1.14.5.2. Flow freeze-protection function.....	page 22
1.14.5.3. Water heater freeze-protection function.....	page 22
1.14.6. Pump and valve anti-seize function.....	page 22
1.14.7. Operation with (optional) external probe.....	page 22
1.14.8. Operation with (optional) Remote Control.....	page 23
1.15. Boiler shut-down.....	page 23
1.15.1. Burner shut-down.....	page 23
1.15.2. Shut-down due to incorrect air/flue gas system draught.....	page 23
1.15.3. Shut-down due to low water pressure.....	page 23
1.15.4. Shut-down for fan malfunction.....	page 24
1.15.5. Alarm due to temperature probe malfunction.....	page 24
1.15.6. Alarm due to Remote Control (optional) connection malfunction.....	page 24
1.16. Maintenance.....	page 24
1.17. Notes for the user.....	page 24
<b>2. Technical features and dimensions.....</b>	<b>page 25</b>
2.1. Technical features.....	page 25
2.2. Dimensions.....	page 26
2.3. Key components.....	page 27
2.4. Hydraulic layout.....	page 28
2.5. Operating data.....	page 29
2.6. General characteristics.....	page 29
<b>3. Instructions for the installer.....</b>	<b>page 31</b>
3.1. Installation standards.....	page 31
3.2. Installation.....	page 31
3.2.1. Packaging.....	page 31
3.2.2. Choosing where to install the boiler.....	page 31
3.2.3. Positioning the boiler.....	page 31
3.2.4. Installing the boiler.....	page 33
3.2.5. Boiler room ventilation.....	page 33
3.2.6. Air intake and flue gas venting system.....	page 34
3.2.6.1. Configuration of air intake and flue gas venting ducts.....	page 35
3.2.6.2. Ø 100/60 mm and Ø 125/80 mm air/flue gas coaxial duct system.....	page 36
3.2.6.3. Air intake and flue gas venting via 80 mm split pipes.....	page 37
3.2.6.4. Air intake and flue gas venting via 60 mm split pipes.....	page 37
3.2.7. Checking combustion efficiency.....	page 38
3.2.7.1. Flue cleaning function.....	page 38
3.2.7.2. Measurement procedure.....	page 38
3.2.8. Connection to gas mains.....	page 39
3.2.9. Hydraulic connections.....	page 39
3.2.10. Connection to the electrical mains.....	page 40
3.2.11. Selecting the operating range in CH mode.....	page 40
3.2.12. Connection to ambient thermostat (optional).....	page 40
3.2.13. Installation and operation with Open Therm Remote Control (optional).....	page 40
3.2.14. Installation of the (optional) external probe and sliding temperature operation.....	page 41
3.2.15. TSP parameters that can be set from interface and Remote Control.....	page 43
3.3. Filling the system.....	page 45
3.4. Starting up the boiler.....	page 45
3.4.1. Preliminary checks.....	page 45
3.4.2. Switching on and switching off.....	page 45
3.5. Available head to the system.....	page 46
3.6. Wiring diagram.....	page 47
3.6.1. Multifunction relay wiring diagram.....	page 48
3.6.2. Multifunction relay setting diagrams.....	page 49
3.7. Adaptation to other gas types and burner adjustment.....	page 51
3.7.1. Switching from Methane gas to Propane gas.....	page 51
3.7.2. Switching from Propane gas to Methane gas.....	page 51
3.7.3. Gas valve setting.....	page 52
3.7.3.1. Maximum heating output adjustment.....	page 52
3.7.3.2. Minimum heat output adjustment.....	page 52

<b>4. Testing the boiler</b> .....	<b>page 54</b>
4.1. Preliminary checks .....	page 54
4.2. Switching on and switching off .....	page 54
<b>5. Maintenance</b> .....	<b>page 55</b>
5.1. Maintenance schedule .....	page 55
5.2. Combustion analysis .....	page 55
<b>6. Troubleshooting</b> .....	<b>page 56</b>
<b>7. Manufacturer's compliance statement</b> .....	<b>page 58</b>

## FIGURE INDEX

fig. 1 - Control panel .....	page 7
fig. 2 - Filler cock .....	page 24
fig. 3 - Dimensions .....	page 26
fig. 4 - Key components .....	page 27
fig. 5 - Hydraulic layout .....	page 28
fig. 6 - Installation template .....	page 32
fig. 7 - Wall mounting .....	page 33
fig. 8 - Installation examples .....	page 34
fig. 9 - Air intake and flue gas venting coaxial pipe system .....	page 36
fig. 10 - Dimensions for connection to air intake and flue gas venting coaxial pipe system .....	page 36
fig. 11 - Air intake and flue gas venting via split pipes .....	page 37
fig. 12 - Dimensions for connection to air intake and flue gas venting via split pipes .....	page 37
fig. 13 - Air intake and flue gas venting tower .....	page 38
fig. 14 - Openings for combustion efficiency measurement .....	page 38
fig. 15 - Gas mains connection .....	page 39
fig. 16 - Central heating curves with external probe operation .....	page 43
fig. 17 - Available head to the system .....	page 46
fig. 18 - Wiring diagram .....	page 47
fig. 19 - Multifunction relay wiring diagram .....	page 48
fig. 20 - Relay with remote control and ambient thermostat 2 .....	page 49
fig. 21 - Relay with interface programming and ambient thermostat 2 .....	page 49
fig. 22 - Relay with remote request .....	page 49
fig. 23 - Relay with request .....	page 49
fig. 24 - Relay with alarm indication .....	page 50
fig. 25 - Adaptation to other gas types .....	page 52
fig. 26 - Removing the mixer .....	page 52
fig. 27 - Changing nozzles .....	page 52
fig. 28 - Fixing the mixer .....	page 52
fig. 29 - Adjustment of the gas valve .....	page 53s

## TABLE INDEX

Table 1 - BOILER STATUS - LCD INDICATIONS during normal operation .....	page 9
Table 2 - BOILER STATUS - LCD INDICATIONS in the event of malfunction .....	page 10
Table 3 - Displayable parameters with info button .....	page 19
Table 4 - Adjustment rates, KB 24 .....	page 29
Table 5 - Adjustment rates, KB 32 .....	page 29
Table 6 - General specifications .....	page 29
Table 7 - Combustion specifications, KB 24 .....	page 30
Table 8 - Combustion specifications, KB 32 .....	page 30
Table 9 - Boiler re-ignition temperatures .....	page 40
Table 10 - Limits to be set for TSP parameters and default values based on boiler type (TSP0) .....	page 41
Table 11 - General table of parameters .....	page 43
Table 12 - Relationship between "Temperature and Nominal resistance" for temperature probes .....	page 50
Table 13 - CO <sub>2</sub> values .....	page 53
Table 14 - Diameter of nozzles - diaphragms page .....	page 53

# 1. INSTRUCTIONS FOR THE USER

## 1.1. Control panel

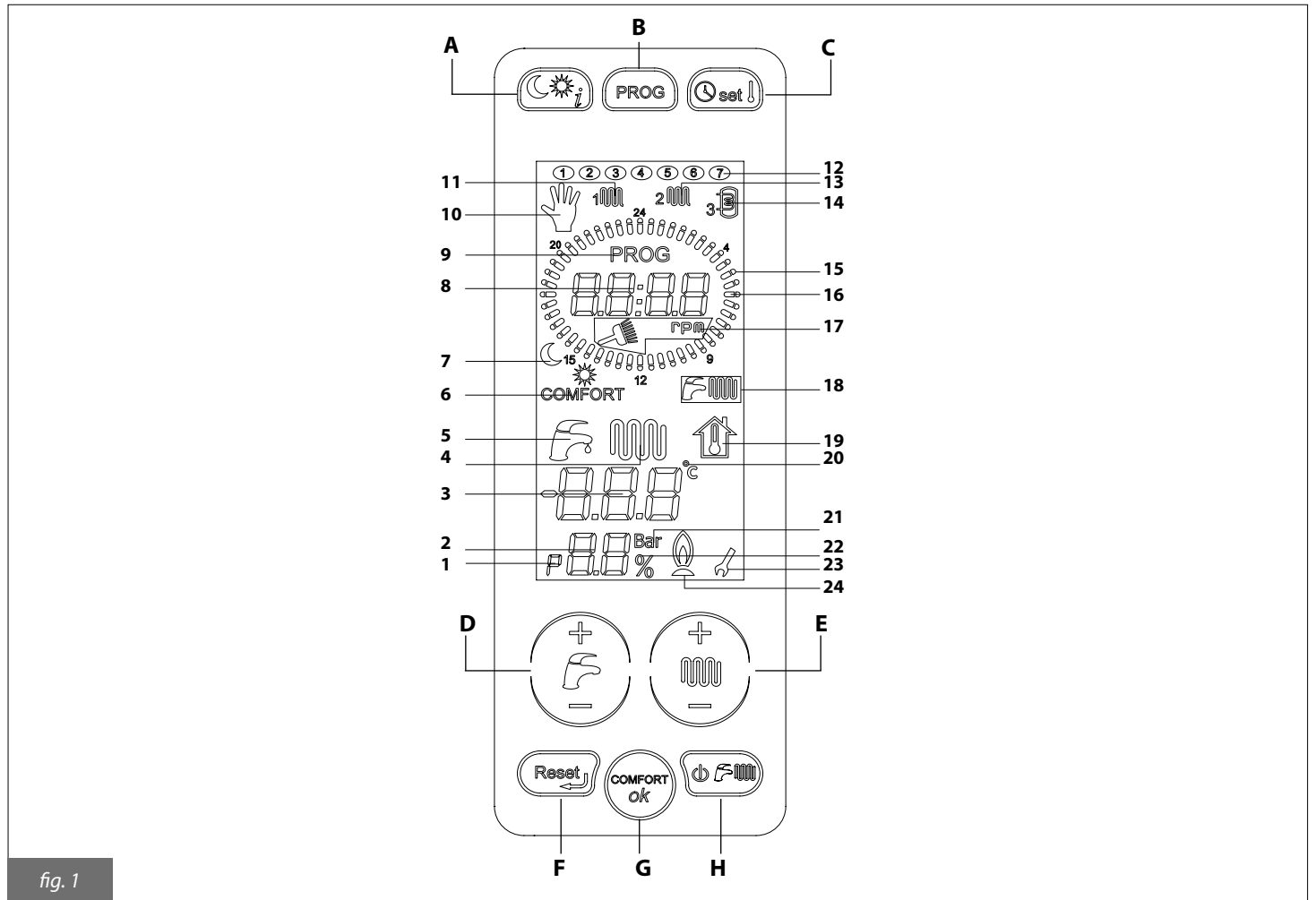

fig. 1

**A.** Temperature selection (day/night) and recall information.

**B.** Weekly programme for temperature zones and manual programme selection.

**C.** Time and ambient temperature setting.

**D.** DHW setting.

**E.** Hot water for heating purposes and parameter setting.



















**F.** Alarm reset and back to the starting page during parameter selection.

**G.** DHW comfort function enabling and confirm key.

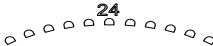
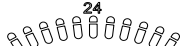
**H.** Operating status selection.

To gain access to the interface, touch the display area.

The interface is enabled and after 15 seconds is disabled, unless a button is pressed.

	<b>SYMBOL</b>	<b>STEADY</b>	<b>FLASHING</b>
1		Indication of "parameter" inside the parameter menu	
2		Automatic filling active	
3		Indication of the temperatures and values of fault and shutdown parameters	
4		A CH request is present	Displaying of the CH temperature set-point
5		A DHW request is present	Displaying of the DHW temperature setpoint
6	COMFORT	Display of DHW "comfort" state: wording ON = comfort enabled; wording OFF = comfort disabled	
7		Current temperature (sun = day; moon = night)	Setting of the two temperatures associated with the sun and the moon
8		Display of current time/fan revolutions	
9	PROG	Indicates if the unit is in time slot programming mode	
10		Manual mode operation	Manual mode setting
11		Display of zone 1 heating programme	Edit CH zone 1 programme
12		Current day of the week	Edit day of the week
13		Display of zone 2 heating programme	Edit CH zone 2 programme
14		Display of water heater programme	Edit water heater programme
15		Night time temperature indication	
16		Daytime temperature indication	All lights flashing: automatic mode setting
17	 rpm	Displaying of the flue cleaning function and of the "rpm" wording to show the number of revolutions per minute	Indicates that you are accessing the flue cleaning function.
18		Symbols for instantaneous DHW, heating. ON = function enabled, OFF = function disabled.	
19			Displaying of the calculated temperature setpoint
20	°C	Indication of the centigrade degrees	
21	Bar	Indication of system pressure measurement unit	
22	%	Percentage indication	
23		During parameter editing, the wrench symbol stays on until the set value is confirmed.	
24		Lit flame indication	



## 1.2. Interpreting BOILER STATUS from LCD DISPLAY INDICATIONS

### Normal operation

<p>Boiler switch in OFF mode</p>	
<p>Boiler switch in SUMMER or WINTER mode or CH ONLY No active function The flow temperature and the heating system pressure are displayed</p>	<div style="display: flex; justify-content: space-around; align-items: flex-end;"> <div style="text-align: center;">   <b>SUMMER</b> </div> <div style="text-align: center;">   <b>WINTER</b> </div> <div style="text-align: center;">   <b>CENTRAL HEATING ONLY</b> </div> </div>
<p>Boiler switch in SUMMER or WINTER mode Water heater enabled - DHW function active DHW temperature displayed (water heater)</p>	<div style="display: flex; justify-content: space-around; align-items: flex-end;"> <div style="text-align: center;">   <b>SUMMER</b> </div> <div style="text-align: center;">   <b>WINTER</b> </div> </div>
<p>Boiler switch in WINTER mode or CH ONLY CH function active The flow water temperature is displayed</p>	<div style="display: flex; justify-content: space-around; align-items: flex-end;"> <div style="text-align: center;">   <b>WINTER</b> </div> <div style="text-align: center;">   <b>CENTRAL HEATING ONLY</b> </div> </div>

Table 1 - BOILER STATUS - LCD DISPLAY INDICATIONS during normal operation

## Malfunction

<b>No flame</b>	E 0 1
<b>Triggering of double flow probe</b>	E 0 2
<b>Triggering of flue gas thermostat</b>	E 0 3
<b>Insufficient system pressure</b>	E 0 4
<b>Flow probe failure</b>	E 0 5
<b>Flue probe failure</b>	E 0 7
<b>Too high system pressure</b>	E 0 9
<b>Water heater probe failure</b>	E 1 2
<b>Return probe failure</b>	E 1 5
<b>Remote Control connection failure (only shown on Remote Control panel)</b>	E 3 1
<b>Triggering of safety thermostat in mixed zone 2</b>	E 3 5
<b>Flow probe failure in mixed zone 2</b>	E 3 6 0 2
<b>Flow probe failure in mixed zone 3</b>	E 3 6 0 3
<b>Flow probe failure in mixed zone 4</b>	E 3 6 0 4
<b>Fan failure</b>	E 4 0
<b>Communication failure between peripheral devices (zone boards, solar)</b>	E 4 1
<b>Hydraulic configuration not allowed</b>	E 4 2

<b>Zone configuration error (remote control and ambient thermostat)</b>	E43
<b>Ambient probe 1 failure</b>	E44
<b>Ambient probe 2 failure</b>	E45
<b>Pressure transducer failure</b>	E46
<b>External probe with connected ambient probe error</b>	E47
<b>Communication error between main board and interface board</b>	E49
<b>Shut-down due to safety circuit hardware fault</b>	E51 E52 E53
<b>Incompatibility between boiler board and interface board</b>	E73
<b>Offset error <math>\Delta T</math> max</b>	E80
<b>Flow or return probe &gt; 120°C</b>	E85
<b>Maximum flow derivative exceeded</b>	E86
<b>Maximum return derivative exceeded</b>	E87
<b>Flue gas temperature lower than heating return temperature</b>	E89
<b>Flue gas maximum threshold exceeded</b>	E90
<b>Flue gas maximum derivative exceeding alarm</b>	E91
<b>Max. number of reset attempts from touch screen reached</b>	E98
<b>Max. number of reset attempts from Remote Control reached (optional, if connected)</b>	E99

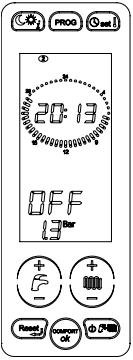
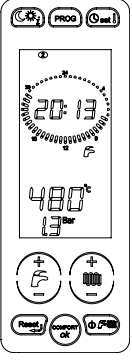
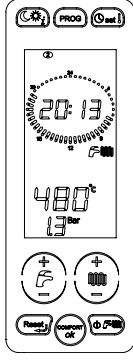
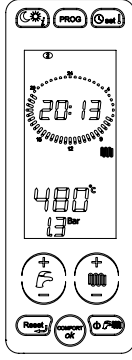
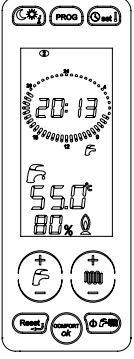
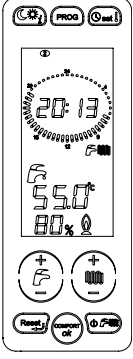
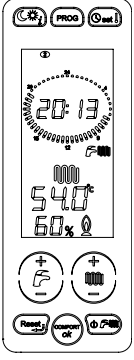
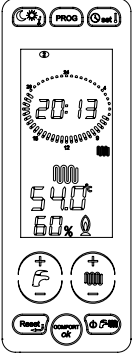
Table 2 - BOILER STATUS - LCD indications in the event of malfunction

### 1.3. "Comfort" enable/disable function

This function always keeps the water heater warm, without considering the programming of water heater heating time (par. 1.10).

When the "COMFORT" icon (6, fig. 1) is on, the function is enabled. When it is off the function is disabled and the boiler carries out the hour programming of the water heater (par. 1.10).

If "COMFORT" function is enabled (icon "COMFORT" 6 in pic.1 on) press "COMFORT" button (G, pic. 1) to disable it. If "COMFORT" function is disabled, press "COMFORT" button to enable it.

The water heater heating through "COMFORT" function, or programming, is carried out only if the boiler is in SUMMER or WINTER operating mode. If the boiler is in CH ONLY or OFF operating mode the water heater is not heated.

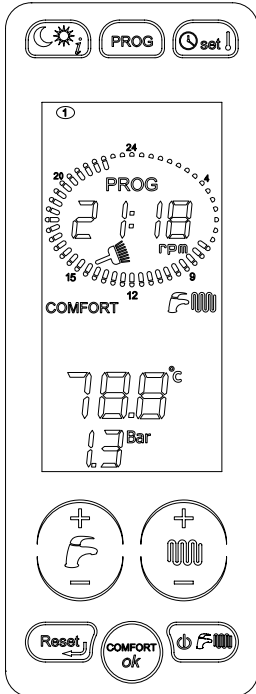

1. "COMFORT" FUNCTION ENABLED

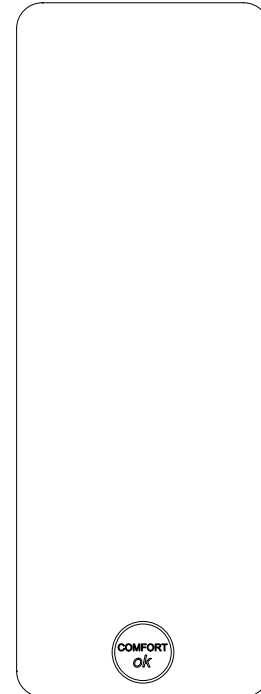



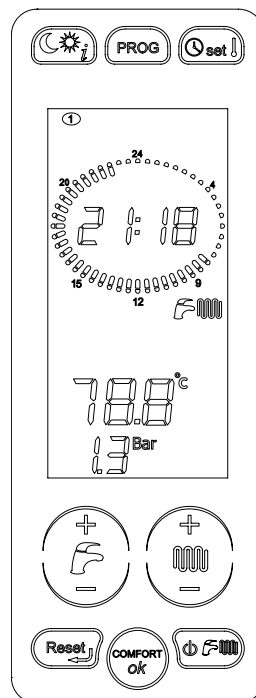

2. PRESS THE COMFORT BUTTON



3. "COMFORT" FUNCTION DISABLED

### 1.4. Selecting the operating mode

Whenever button  is pressed, the "SUMMER" , "WINTER" , "CH ONLY" , "OFF" modes are enabled in sequence.

At this stage, all buttons are enabled.

When the "SUMMER" mode is enabled, only the DHW production function is active.

When the "CH ONLY" mode is enabled, only the C<H water production function is active.

When the "WINTER" mode is enabled, both DHW and CH functions are active.

When the "OFF" mode is enabled, no function is active.

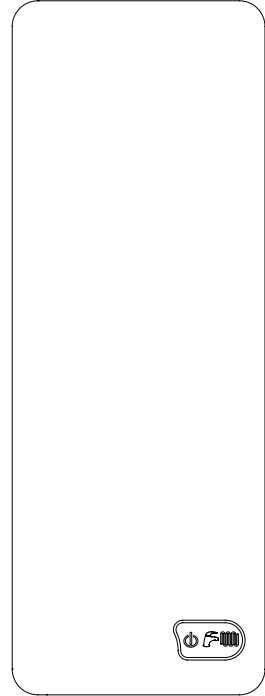
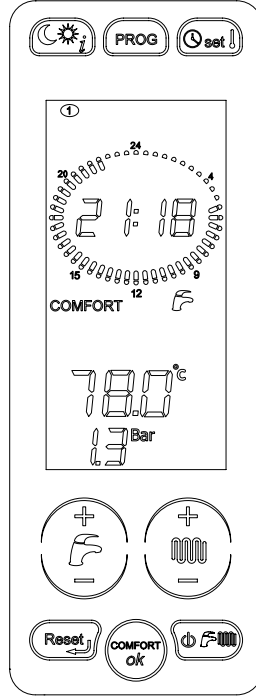
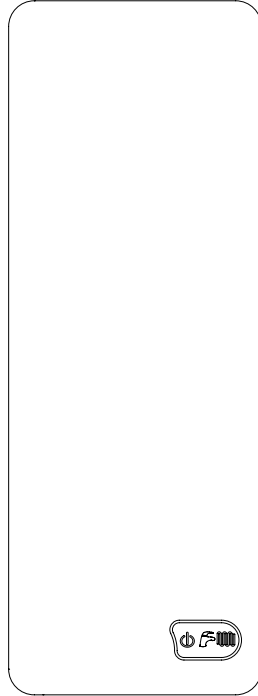
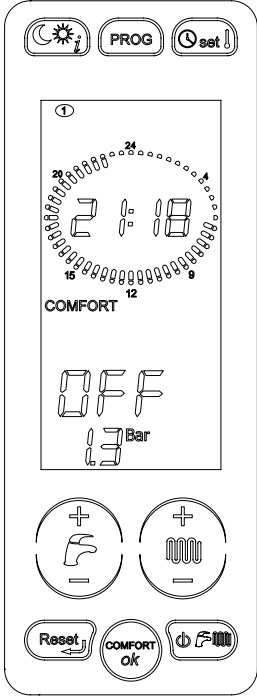

1. OPERATING STATUS  
OFF

2. SUMMER  
OPERATING STATUS

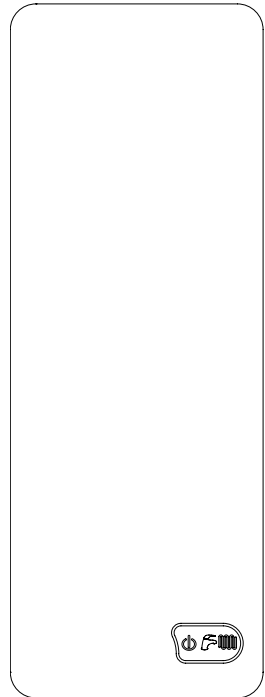
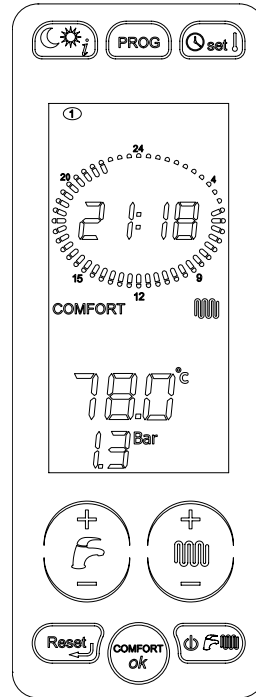
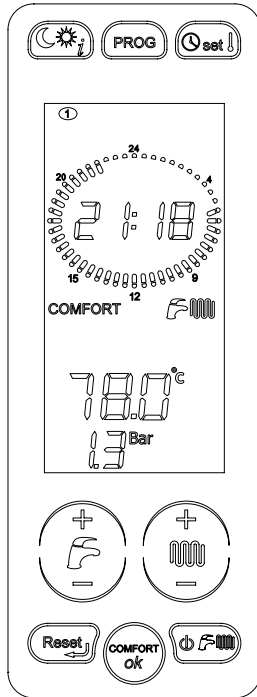

3. WINTER  
OPERATING  
STATUS

4. CH ONLY  
OPERATING  
STATUS

## 1.5. Adjusting heating and DHW temperature

Press the "DHW + and -" button (D, fig. 1) to select the desired domestic hot water temperature. During selection, DHW icon (6, fig. 1) will flash. As soon as button is released, icon will continue flashing for approx. 3 seconds, and temperature value will flash as well. After this time, value is stored and display standard operation will be restored. In the phase in which the icon is flashing, only the buttons to adjust the temperature of the DHW are enabled.

Press the "CH + and -" button (E, fig. 1) to select the desired flow water temperature. During selection, heating icon (5, fig. 1) will flash. As soon as button is released, icon will continue flashing for approx. 3 seconds, and temperature value will flash as well. After this time, value is stored and display standard operation will be restored. In the phase in which the icon is flashing, only the buttons to adjust the heating temperature are enabled.

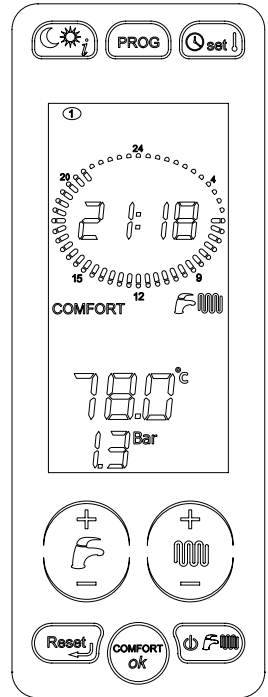
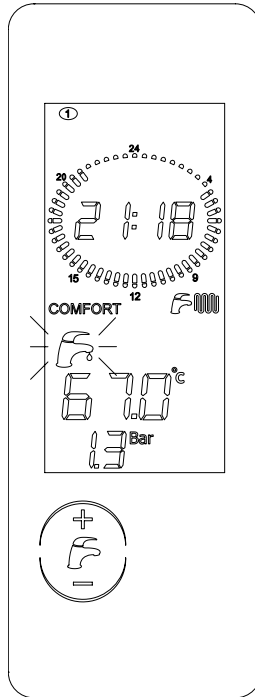
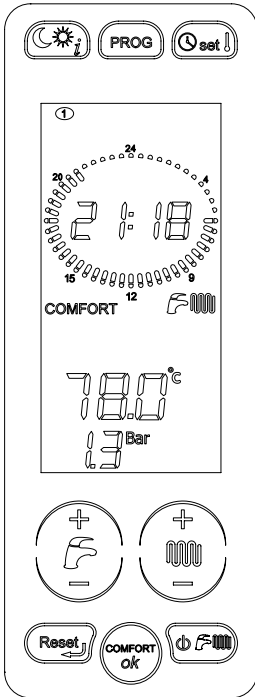

1. DHW  
TEMPERATURE  
SETTING

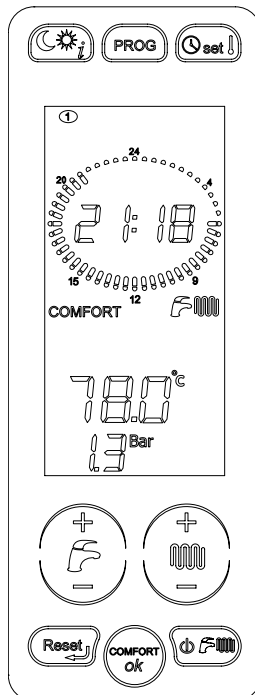
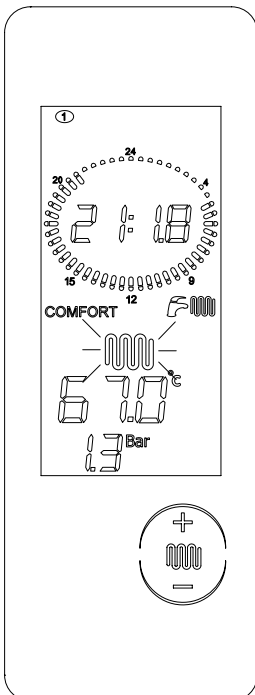

2. CH  
TEMPERATURE  
SETTING

## 1.6. Time setting

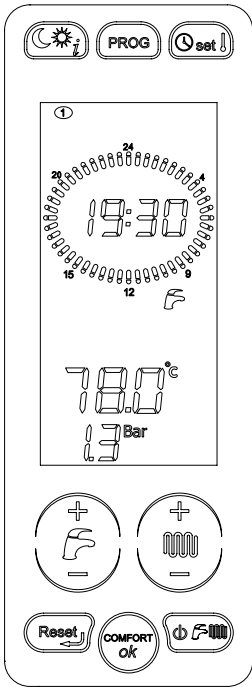

1- To set time, minutes and day of the week, press "set".

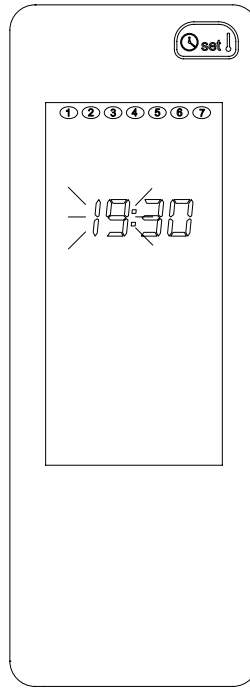

2- Flashing values can be edited by pressing "CH + and -" buttons. Press "ok" to confirm the edited value and shift to next parameter, press "reset" to quit the function and go back to starting page. Press "set" to access the day and night setting function described in the following paragraph.

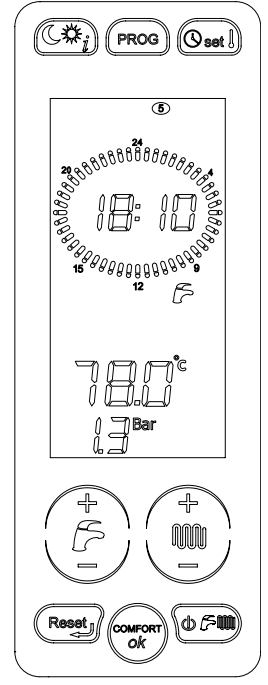
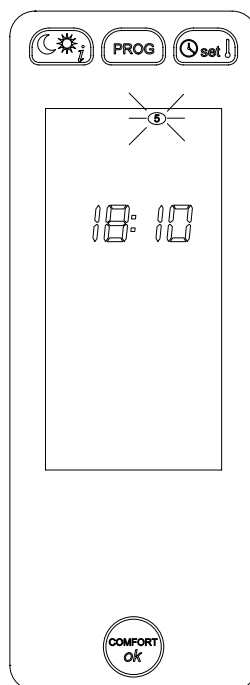
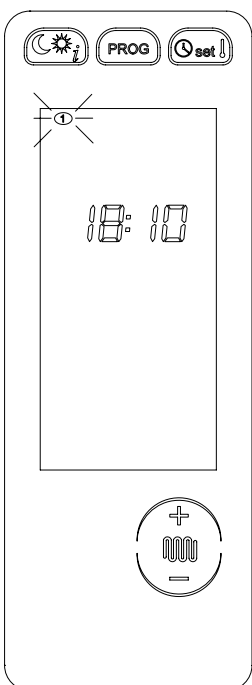
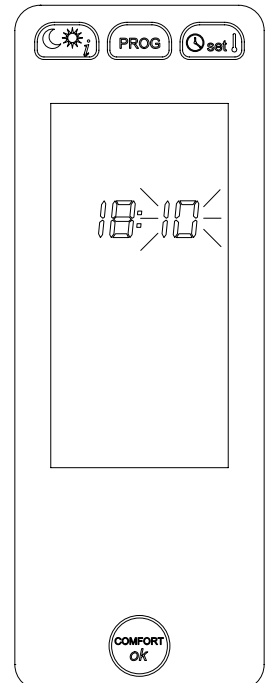
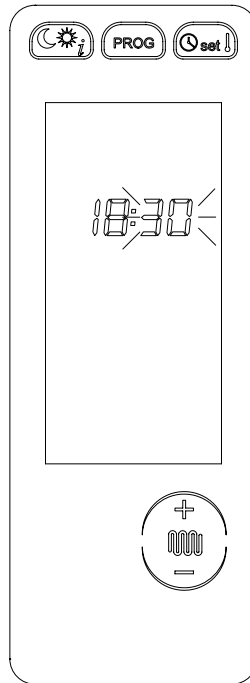
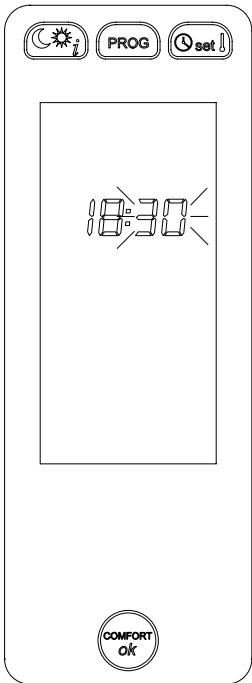
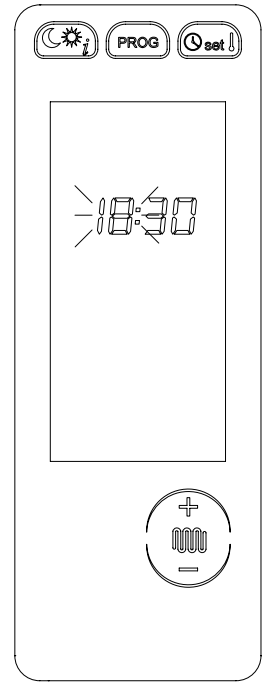

## 1.7. "Day temperature" and "night temperature" setting

When one or more ambient probes are connected to boiler electronic board, two levels of desired ambient temperatures can be set. Boiler will manage the heating request based on the set temperatures, as follows. If no ambient probe is connected to the boiler, temperatures cannot be set. "Day" temperature is identified by the symbol ☀, while "night" temperature by the symbol 🌙.

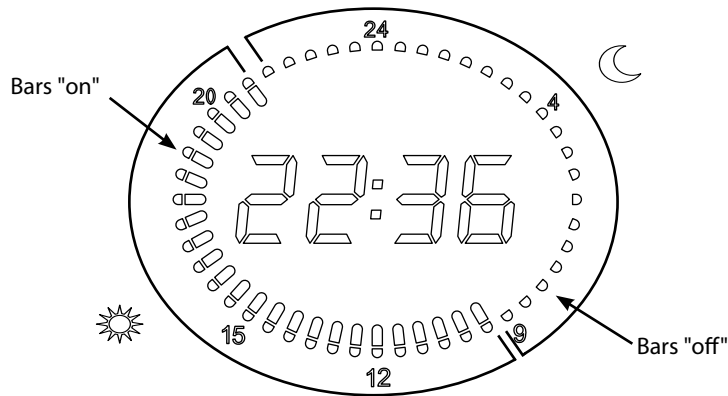

The "day temperature" is active when bars are on, while "night" temperature is active when bars are off.

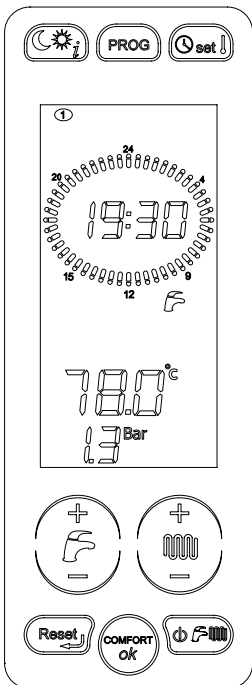

1- Press "set" twice to access the "day temperature" setting mode.

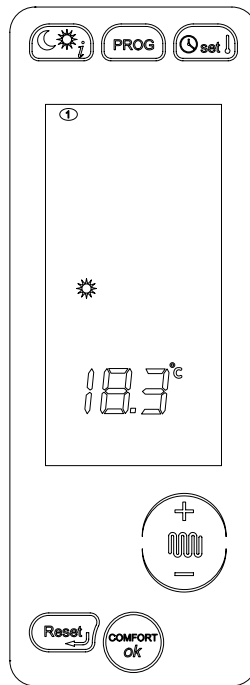

2- Press "CH + / -" buttons to edit "day temperature" values. Press "ok" to confirm the edited values and enter the "night temperature" setting mode.

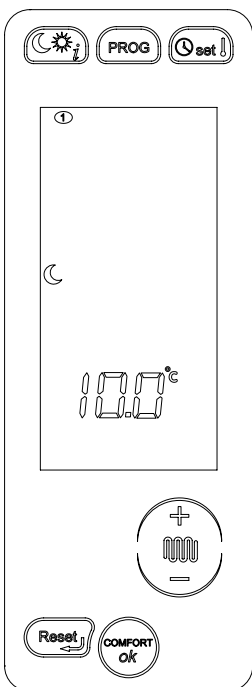
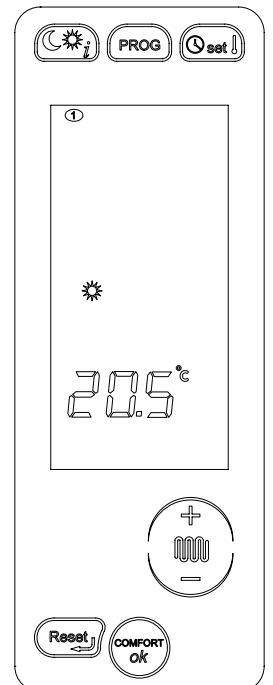

3- Press "CH + and -" buttons to edit "night temperature" values.

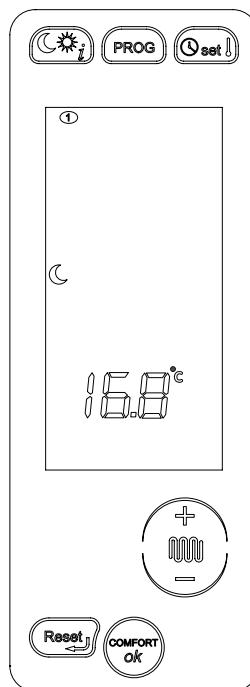

4- Press "ok" to confirm the edited values and quit the "day and temperature" setting mode.

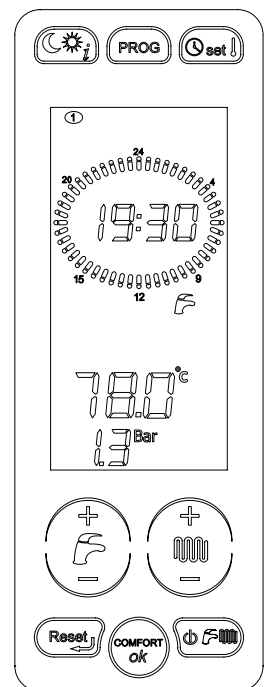



## 1.8. "Manual" programme setting

The "manual" mode selection indicated with symbol , allows activating the heating function, 24 hours a day, in both zones at the "day temperature", disabling at the same time zone 1 and zone 2 programming. Boiler, on the other side, is heated according to the specific programme.

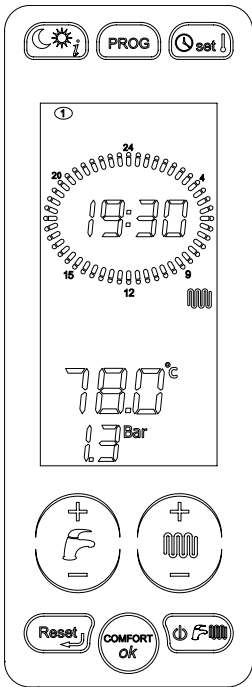

1- Press "prog" to access the manual programme setting mode.

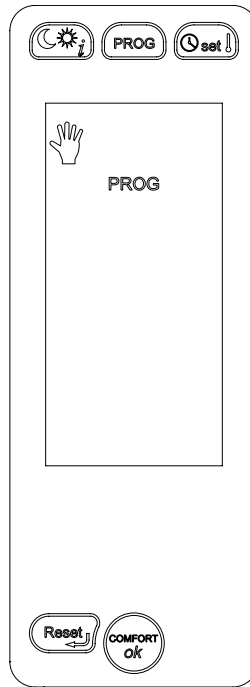

2- Press "ok" to confirm manual programming activation. Press "reset" to go back to the starting page, namely to quit the function.

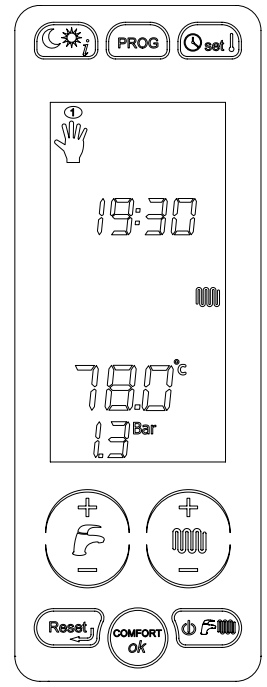

## 1.9. "Automatic" programme setting

The selection of "automatic" mode, identified by symbol , allows boiler to enable heating of both zones in "day temperature" or "night temperature", based on the programming envisaged for zone 1 and zone 2.

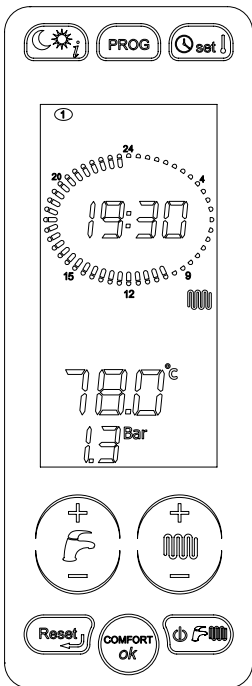

1- Press "prog" to access the automatic programme setting mode.

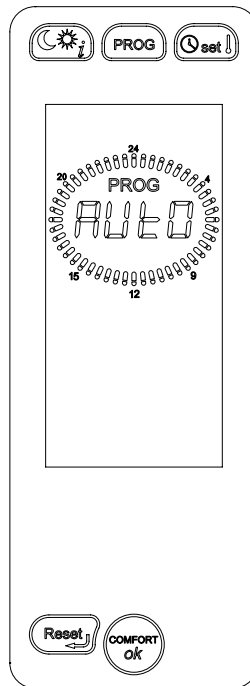

2- Press "ok" to confirm automatic programming activation. Press "reset" to go back to the starting page, namely to quit the function.

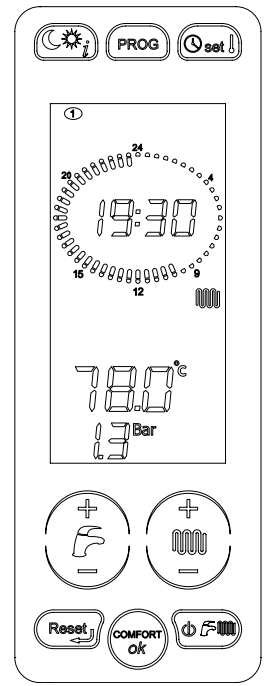

## 1.10. Programming mode for CH and water heater

To access zone 1 heating programme displaying or editing, press "prog" button twice.

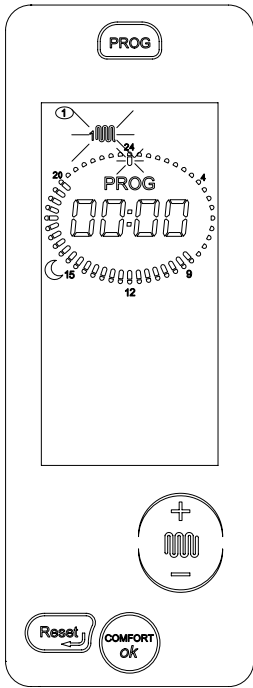

**1-** The display shows zone 1 symbol flashing, sun or moon symbols, bars on or off, respectively, at 00:00. Clock lights display the programming connected to day 1 (Monday) and 00:00 bar is flashing.

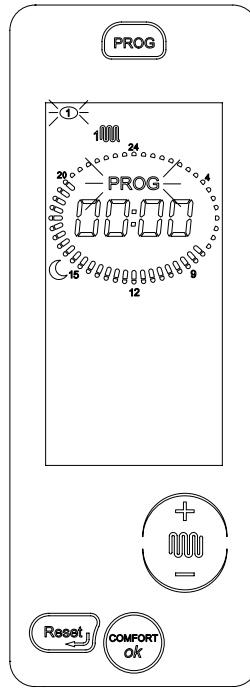

**2-** Press "ok" to access zone programming function. "Prog" wording starts flashing together with number 1 (Monday). Press "CH + and -" buttons to select the desired day of the week. Press "ok" to select the desired day. Now you can associate the day/night level to the desired time of the day.

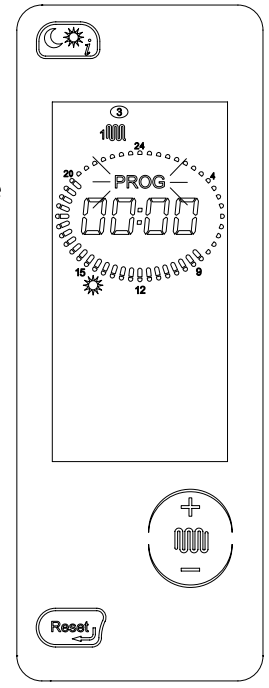

**3-** Whenever "sun/moon" button is pressed sun and moon symbols activate alternately (sun = day level; moon = night level). At the same time, close to the current time (flashing bar) clock bar comes on if the "sun" icon is on, and turns off the "moon" icon is off. Current time is indicated by both the clock and the flashing bar. Press "CH + and -" buttons to move inside the different times of the day.

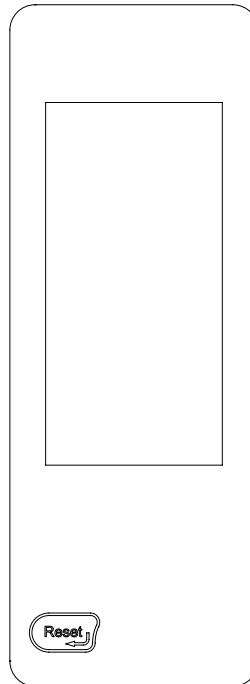

**4-** To program other days of the week or to program zone 2 and water heater, press "reset". You will go back to the starting page.

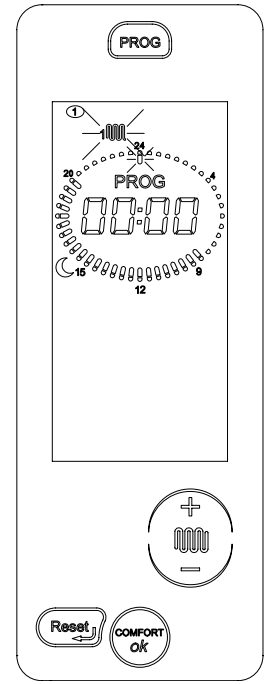

Whatever part of the programme can be quit by pressing the "reset" button twice. The procedure to program zone 2 and water heater, is very similar to the one followed to program zone 1. Press "prog" to access the 4 following programmes in a sequence: manual; zone 1; zone 2; water heater.

If ambient probes are connected, the "day temperature" level and the "night temperature" will acquire the temperature value, and heating will be active until the temperature measured by the ambient probe reaches the preset value for the different time slots. When no ambient probe is connected, the two day/night levels will acquire the on and off values. So heating is ON in the selected periods with the sun symbol, while it is OFF in the selected periods with the moon symbol. In case of connection with Open Therm remote control, that zone shall not be managed by boiler boards, as it will be directly managed by the remote control and, as a consequence, zone programming will be inhibited.

## 1.11. Parameter display

Press "Info" (A, fig. 1) to scroll the different parameter values. You can quit this function at any time by simply pressing the "Reset" button. Paragraph 3.2.15 describes the meaning of all parameters.

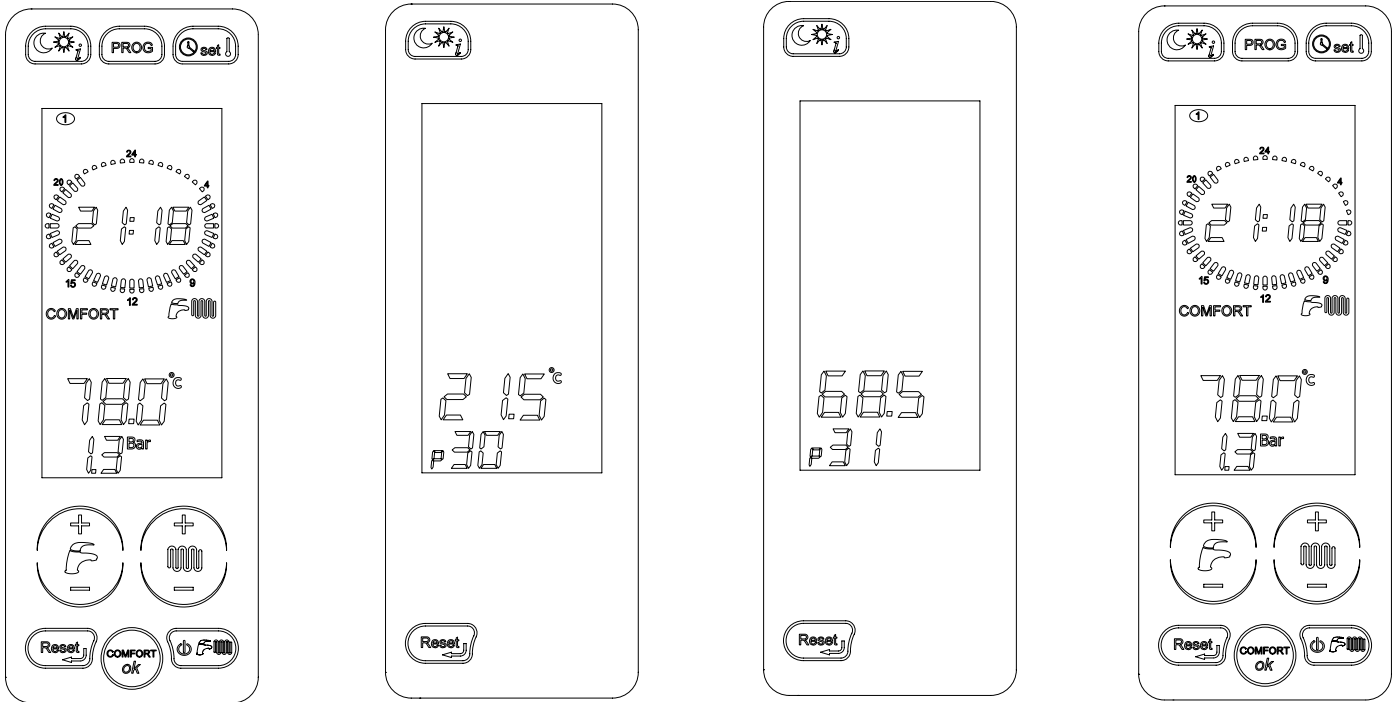

PARAMETERS	DESCRIPTION
P30 - TSP30	<b>External temperature</b> displaying (if an external probe is present).
P31	<b>Flow temperature</b> displaying.
P32	<b>Calculated nominal flow temperature</b> displaying. If no external probe is installed, the flow temperature manually set on boiler will be displayed. If an external probe is installed, the flow temperature boiler calculated through the curves on fig.16 will be displayed
P43	<b>Return temperature</b> displaying.
P44	<b>Water heater temperature</b> displaying.
P45	<b>Flue gas temperature</b> displaying.
P49	<b>Ambient probe 1 temperature</b> displaying (if connected to ambient probe 1).
P50	<b>Ambient probe 2 temperature</b> displaying (if connected to ambient probe 2).

Table 3 - Displayable parameters with info button

### 1.12. Failures that cannot be reset

The display shows the failure based on the corresponding error code (see paragraph 1.2). Some failures can be reset through the reset key, while some others are self-resettable. Refer to the following paragraph ("Resume boiler function").  
If failures cannot be reset but are of the self-resettable type, no key will be enabled and only the LCD back-lighting will be on. As soon as the error cause is eliminated, the failure signal will disappear from the interface, this latter will be enabled and, 15 seconds after no key is touched, all the keys but the one around the LCD will be disabled.

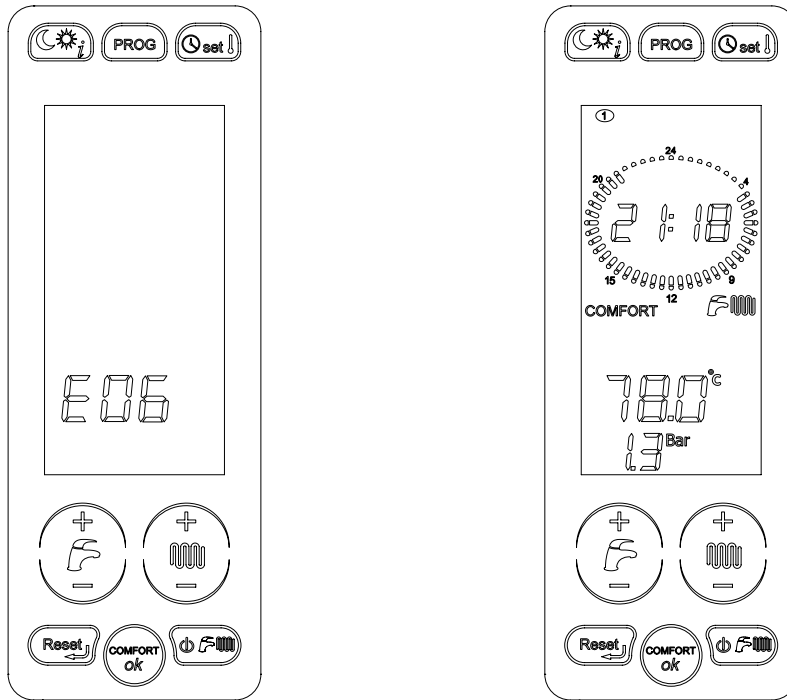

### 1.13. Resume boiler function

The display shows the failure based on the corresponding error code (see paragraph 1.2). Some failures can be reset through the reset key, while some others are self-resettable.

If shut-downs can be reset (E01, E02, E03, E40, E80, E86, E87), the reset key and the LCD back-lighting will always be on. The only active key you can press is the "reset" key.

When the reset key is pressed and boiler is under the correct conditions, the error is reset. The failure signal will disappear from the interface, this latter will be enabled and, 15 seconds after no key is touched, all the keys but the one around the LCD will be disabled.

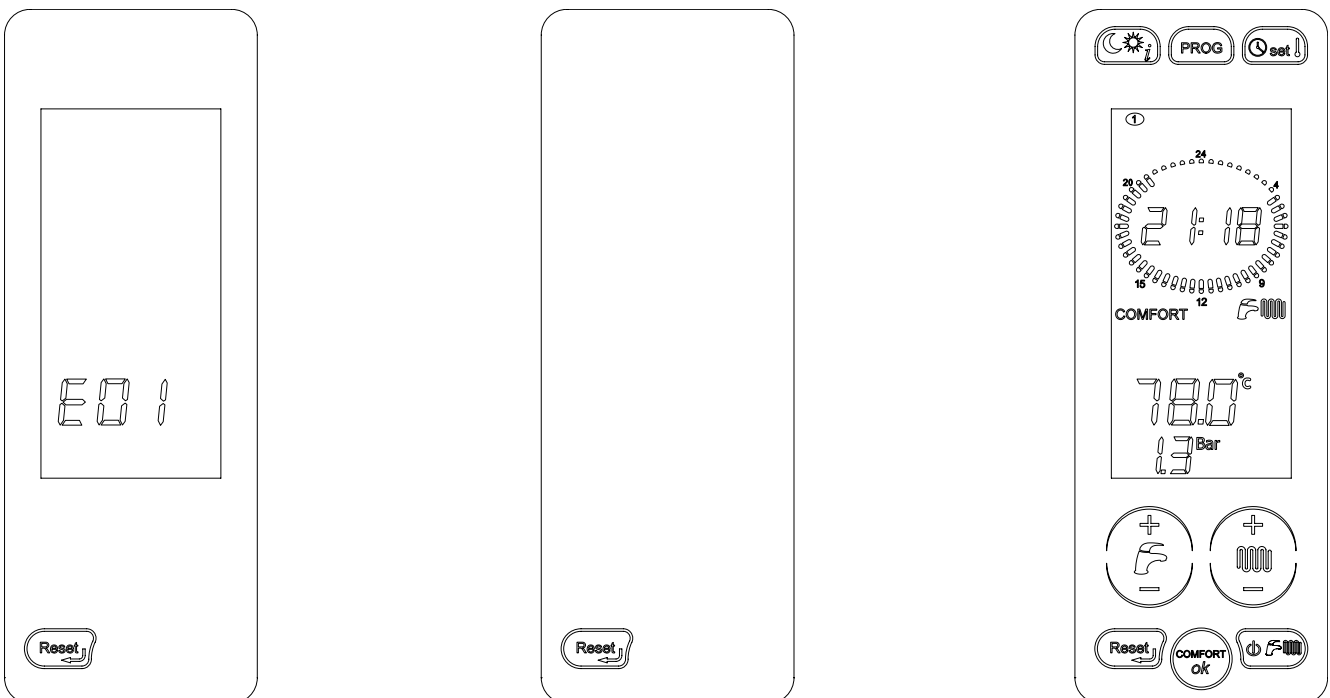

## 1.14. Boiler operation

### 1.14.1. Switching on

 **It is presumed that the boiler has been installed by a qualified installer, it has been commissioned and is ready to operate correctly.**

- Open the gas stop cock;
- turn the master switch installed ahead of the boiler ON. The display turns on and indicates the function currently active (see tables 1 and 2);
- select boiler operating mode pressing "Operating mode selection" button on the touch-screen (**H**, fig.1): OFF, SUMMER, WINTER, CH ONLY (paragraph 1.4.);
- set desired CH temperature (see par. 1.14.2);
- set desired DHW temperature (see par. 1.14.3);
- if one or more ambient probes or an ambient thermostat are present, set the desired ambient temperature value and the weekly programming;

#### WARNING

**Should the boiler be left inactive for a long time, particularly when boiler is propane-fired, ignition might be difficult. Before starting the boiler switch on another gas powered device (e.g. kitchen range).**

**Beware that even by following this procedure, the boiler might still experience some starting difficulties and shut down once or twice. Reset boiler operation by pressing the "reset" button (**F**, fig. 1).**

### 1.14.2. CH function

Set desired CH water temperature via "CH + and -" buttons (**E**, fig. 1).

Heating temperature adjustment range depends on the selected operating range:

- **standard range:** 20°C to 78°C (press "CH + and -" buttons **E**, fig. 1);
- **reduced range:** 20°C to 45°C (press "CH + and -" buttons).

The operating range shall be selected by the installing technician or by a qualified Service Centre (see paragraph 3.2.11.).

During temperature setting, the CH symbol (**5**, fig.1) on the screen flashes and the CH current setting is displayed.

When the central heating system requests heat from the boiler, the LCD displays the CH symbol steady on (**5**, fig.1) and the current heating flow water temperature. The burner on symbol (**26**, fig.1) only shows while the burner is operating. The waiting time between one boiler ignition and the following one, used to prevent boiler frequent turning on and off, ranges between 0 and 10 minutes (default value: 4 min.), and can be edited with the **P11** parameter.

Should water temperature in the system fall below set minimum value, between 20°C and 78°C (default value for standard range: 40°C, default value for reduced range: 20°C) to be edited with the **P27** parameter, the waiting time is reset and the boiler re-ignites (see paragraph 3.2.11.).

### 1.14.3. DHW function

The boiler is equipped with a stainless steel water heater with 45 litres single coil.

DHW production function may be enabled by the user in two ways:

- setting a water heater hour programming on the boiler (paragraph 1.10);
- using COMFORT function (paragraph 1.3).

DHW temperature may be set within a range from 35°C to 65°C.

Temperature may be set by pressing "DHW + and -" buttons (**D**, fig. 1).

During temperature setting, the DHW symbol (**6**, fig. 1) on the display flashes and the DHW setting is displayed.

The water heater heating through "COMFORT" function, or programming, is carried out only if the boiler is in SUMMER or WINTER operating mode. If the boiler is in CH ONLY or OFF operating mode, the water heater is not heated.

Boiler electronics always gives priority to DHW over CH supply.

### 1.14.4. Anti-legionella function

Every 15 days the anti-legionella function is enabled. It gets the water heater temperature to 65 °C for 30 minutes, regardless of any other setting, in order to prevent or remove possible proliferation of bacteria inside the water heater

### 1.14.5. Freeze-protection function

This boiler is fitted with a freeze protection system, which works when the following functions are activated: OFF/SUMMER/WINTER/CH ONLY.



**The freeze protection function only protects the boiler, not the whole heating system. Ambient probes or a room thermostat must be used to provide freeze protection for the central heating system. Bear in mind, however, that they are disabled when the boiler is in OFF operating mode. To protect the system, as well as the boiler, set the boiler to WINTER operating mode.**

The central heating system can be effectively protected against icing by using specific anti-freeze products that are suitable for multi-metal systems. **Do not use anti-freeze products for car engines, and check the effectiveness of the product used over time.**

In case burner cannot be ignited due to the lack of gas, the freeze protection functions are anyway enabled through the circulation pumps.

#### 1.14.5.1. Ambient probe freeze protection function

If the board is OFF, or in SUMMER mode, and the ambient probes detect a temperature below 5°C, a heating request to heat the probe-controlled room is launched. The heating function ends when the probe ambient temperature reading reaches 6°C.

#### 1.14.5.2. Flow freeze protection function

When the heating water temperature sensor detects a water temperature of 5°C, the boiler switches on and stays on at its minimum heat output until the temperature reaches 30°C or 15 minutes have elapsed. The pump continues to operate even if the boiler shuts down.

#### 1.14.5.3. Water heater freeze protection function

When water heater temperature sensor detects a water temperature of 5°C, the boiler switches on and stays on at its minimum heating output until the temperature of the water heater water reaches 10°C or 15 minutes have elapsed. The pump continues to operate even if the boiler shuts down.

During the boiler anti-freeze operation the temperature detected by the flow probe is constantly checked, and in case it reaches 60°C the burner is switched off. The burner is switched on again if the operation request in anti-freeze mode is still present and the flow temperature is below 60°C.

### 1.14.6. Pump and valve anti-seize function

If the boiler remains inactive and connected to the power mains, the circulation pump and the deviating valve will be shortly enabled every 24 hours so as to avoid any shut-down. The same applies to the relay which can be freely programmed whenever this latter is used to power a recirculation pump or a deviating valve.

### 1.14.7. Operation with (optional) external probe

Boiler can be connected to a probe measuring the external temperature (optional - not compulsory, supplied by the manufacturer). Once the outdoor temperature is known, the boiler sets automatically the heating water temperature, increasing it when the outdoor temperature decreases and decreasing it when the outdoor temperature increases, in order to improve the ambient comfort and to save fuel. Standard and reduced range max. temperature values will nevertheless be respected.

This boiler operating mode is called "sliding temperature operation".

Heating water temperature varies based on a programme written inside boiler electronic microprocessor.

#### **With external probe, "CH + and -" buttons (E, fig. 1) lose their heating water**

**temperature setting function** and become buttons to change calculated ambient temperature, i.e. the theoretical temperature desired in the area to be heated.

During temperature setting, the calculated ambient temperature symbol flashes on the display (20, fig. 1) and the value being set is shown.

For curve optimal setting, a position close to 20° C is recommended. For further details on sliding temperature, refer to paragraph 3.2.14.



**Only original external temperature probes supplied by the manufacturer must be used. The use of non-original external temperature probes, with technical specifications differing from those required by the managing electronics, may affect boiler and external probe operation.**

### 1.14.8. Operation with (optional) remote control

Boiler interface includes all the possible functions of a Fondital remote control, and can control up to two heating zones. User can also connect the boiler to a Remote Control (optional - not compulsory, supplied by the manufacturer) so as to manage several boiler parameters, such as:

- boiler status;
  - ambient temperature selection;
  - CH water temperature;
  - DHW water temperature;
  - CH or water heater activation times programming;
  - boiler diagnostics display;
  - boiler reset;
- and others.

For instructions on how to connect the Remote Control, refer to par. 3.2.13 and to its own instruction booklet.

 **Only original remote controls supplied by the manufacturer must be used. The use of non-original remote controls, not supplied by the manufacturer, may affect Remote Control and boiler operation.**

### 1.15. Boiler shut-down

The boiler shuts down automatically if a malfunction occurs. Refer to Tables 1 and 2 to identify the boiler operating mode. To determine the possible causes of malfunction, see also paragraph 6. The troubleshooting section is at the end of this manual. Below is a list of kinds of shut-down and the procedure to follow in each.

#### 1.15.1. Burner shut-down

Fault code **E01** is displayed flashing on the display in the event of burner shut-down due to missing flame. If this happens, proceed as follows:

- check that the gas cock is open and light a kitchen gas ring for example to check the gas supply;
- once having checked if the fuel is available, press the "reset" button (F, fig. 1) to restore burner operation: if, after two starting attempts, the boiler still fails to start and enters the shut-down mode again, contact a Service Centre or qualified personnel for maintenance.

If the burner shuts down frequently, there is a recurring malfunction, so contact a Service Centre or a qualified service engineer.

#### 1.15.2. Shut-down due to incorrect air/flue gas system draught

If the air/flue gas system malfunctions, the boiler shuts down. The code **E03** (flue gas thermostat) is displayed flashing on the display. Contact a Service Centre or a qualified service engineer to carry out the maintenance.

#### 1.15.3. Shut-down due to low water pressure

If "shut-down due to insufficient pressure in system" error **E04** starts flashing (indicating safety water pressure switch triggering), fill the system by opening the filler cock as shown in fig. 2. Error **E04** is displayed when system pressure goes below 0.4 bar, and error will be automatically reset as soon as system pressure reaches 1.0 bar. Water pressure must be 1-1.3 bars while the boiler is cold. In order to restore water pressure, proceed as follows:

- turn the filler cock (fig. 2) anticlockwise to allow water to enter the boiler;
- keep the cock open until the control panel shows a value of 1÷1,3 bar;
- turn cock clockwise to close it.

If the boiler still fails to operate, contact a Service Centre or a qualified service engineer.

 **Make sure you close the cock carefully after filling. If you do not, when the pressure increases, error E09 may be displayed and the heating system safety valve may activate and discharge water.**

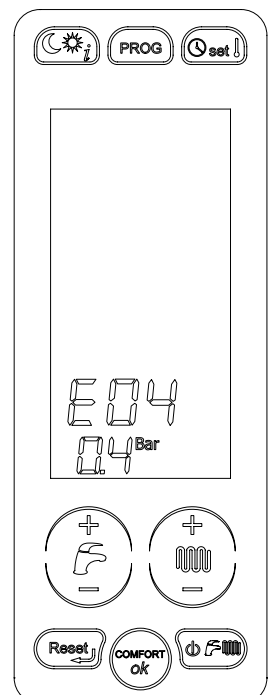

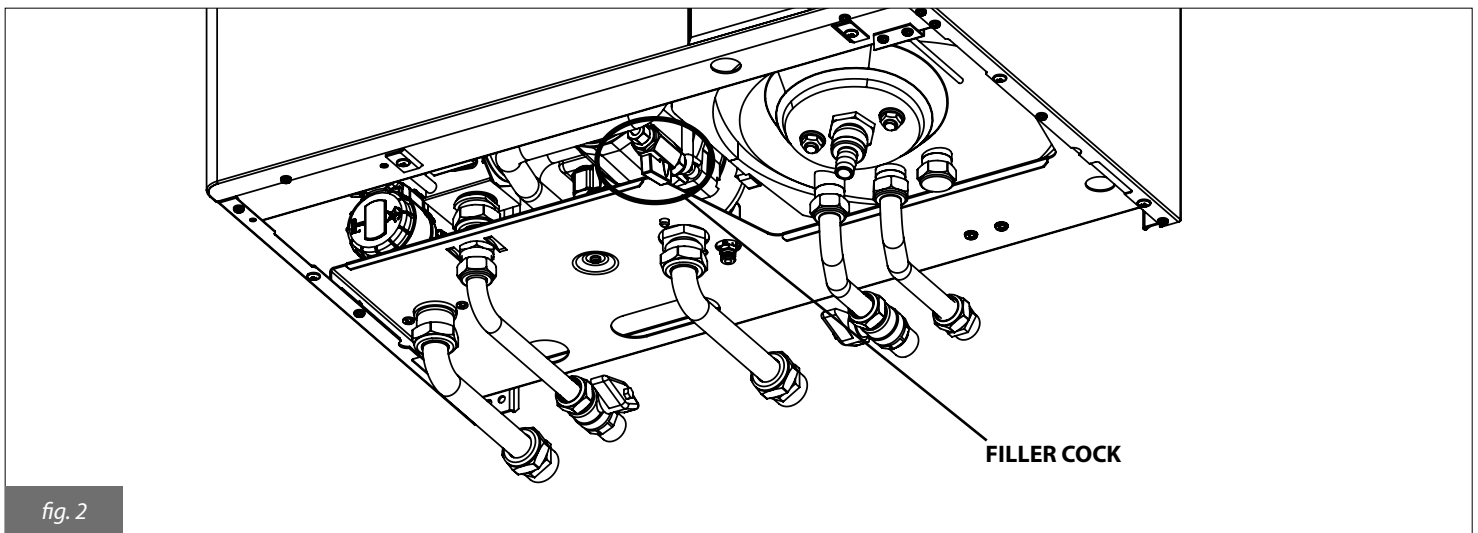

fig. 2

#### 1.15.4. Shut-down for fan malfunction

The fan operation is constantly monitored and in case of malfunction the burner goes off; the code **E40** flashes on the display. This mode is maintained until the fan recovers normal working parameters.

**If the boiler does not start and remains in this mode, contact a Service Centre or a qualified service engineer.**

#### 1.15.5. Alarm due to temperature probe malfunction

The following fault codes are shown on the display in the event of burner shut-down due to a temperature probe fault:

- **E05** for the CH probe.  
In this case the boiler does not work.
- **E12** for the water heater probe.  
In this case, the boiler works in central heating mode only, and the DHW function is disabled.
- **E15** for the return probe.  
In this case the boiler does not work.

In all cases, contact a Service Centre or a qualified engineer for maintenance.

#### 1.15.6. Alarm due to (optional) Remote Control connection malfunction

The boiler recognises whether or not there is a Remote Control (optional).

If the boiler does not receive information from the remote control after the remote control itself is connected, the boiler attempts to re-establish communication for 60 seconds, after which the fault code **E31** is shown on the remote control display.

The boiler will continue to operate according to the settings on the touch screen panel and ignore the Remote Control settings.

Contact a Service Centre or a qualified service engineer.

The remote control can indicate faults or shut-down conditions and can also restore boiler operation after shut-down up to a maximum of 3 times in a 24 hour period. If the maximum number of attempts is reached, fault code **E99** is shown on the boiler display. To reset error **E99**, disconnect and re-connect again boiler from/to power mains.

### 1.16. Maintenance

**The boiler must be serviced periodically as indicated in the relevant section of this manual.**

**Appropriate boiler maintenance ensures efficient operation, environment preservation, and safety for people, animals and objects. Maintenance and repairs must be performed by qualified personnel.**

**The user is strongly advised to have the boiler serviced and repaired by a qualified Service Centre.**

#### 1.17. Notes for the user

**The user may only access parts of the boiler that can be reached without using special equipment or tools. The user is not authorised to remove the boiler casing or to operate on any internal parts.**

**No one, including qualified personnel, is authorised to modify the boiler.**

**The manufacturer shall not be held responsible for damage to people, animals, or property due to tampering with or improper intervention to the boiler.**

**If the boiler remains inactive and the power supply is switched off for a long time, it may be necessary to reset the pump. This involves removing the casing and accessing internal parts, so it must only be carried out by suitably qualified personnel. Pump failure can be avoided by adding to the water filming additives suitable for multi-metal systems.**



## 2. TECHNICAL FEATURES AND DIMENSIONS

### 2.1. Technical features

The boiler is equipped with a fully pre-mixed gas burner. The following model is available:

- **KB**: condensing boiler with sealed chamber and forced draught, supplying CH water and DHW through integrated water heater.

The following power rates are available:

- KB 24: with heat input of 23.7 kW
- KB 32: with heat input of 30.4 kW

All models are equipped with electronic ignition and ionisation flame sensing device.

The boilers meet local applicable Directives enforced in the country of destination, which are stated on their rating plate. Installation in any other country may be a source of danger for people, animals and property.

The key technical features of the boilers are listed below.

### Manufacturing characteristics

- IPX4D electrically protected control panel.
- Integrated, modulating electronic safety board.
- Electronic start-up with built-in igniter and ionisation flame detection.
- Stainless steel, fully pre-mixed burner.
- Mono-thermal, high efficiency, composite and stainless steel heat exchanger with air purging device.
- Twin shutter modulating gas valve with constant air/gas ratio.
- Modulating, electronically managed combustion fan.
- 3-speed circulation pump with built-in air purging device.
- CH pressure sensor.
- CH water flow probe.
- Flue gas thermostat on discharge tower.
- Flue gas probe on primary heat exchanger.
- Integrated, automatic by-pass.
- CH expansion vessel - 10 litres.
- CH system manual filling and draining cocks.
- Motorised deviating valve.
- 45-litre stainless steel DHW water heater.
- Sacrificial magnesium anode.
- CH water return probe.
- Water heater temperature probe.
- DHW expansion vessel - 2 litres.
- Water heater drain manual cock.
- 3-bar heating safety valve.
- 7-bar DHW safety valve.

### User interface

- Built-in touch screen interface to display and control boiler operating conditions: OFF, WINTER, SUMMER and CH ONLY.
- CH water temperature regulator: 20-78°C (standard range) or 20-45°C (reduced range).
- DHW temperature regulator: 35-65 °C .

### Operating features

- CH electronic flame modulation with timer-controlled rising ramp (60 seconds, adjustable).
- Electronic flame modulation in DHW mode.
- DHW priority function.
- Flow anti-freeze function: ON 5°C; OFF 30°C or after 15 minutes of operation if CH temperature > 5 °C.
- Water heater anti-freeze function: ON 5°C; OFF 10 °C or after 15 minutes of operation if boiler temperature > 5 °C.
- Timer-controlled flue cleaning function: 15 minutes.
- Anti-legionella function.
- CH Maximum heat input parameter adjustment.
- Ignition heat input adjustment parameter.
- Possibility to select the heating range: standard or reduced.
- Ignition flame propagation function.
- CH thermostat timer: 240 seconds (adjustable).
- Heating pump post-circulation function in CH, anti-freeze and flue cleaning modes: 30 seconds (adjustable).
- DHW post-circulation function: 30 seconds.
- Post-circulation function for heating temperature > 78 °C: 30 seconds.
- Post-ventilation function after working: 10 seconds.
- Post-ventilation function for heating temperature > 95°C.
- Circulation pump and deviating valve anti shut-down function: 30 seconds of operation after 24 hours of inactivity.
- Ready for connection to an ambient thermostat.
- Ready for operation with an external probe (optional, supplied by the manufacturer).
- Ready for operation with an OpenTherm remote control (optional, supplied by the manufacturer).
- Ready for operation with a module for different temperature zones.
- Ready for chronothermostat function on the boiler, in combination with two ambient probes.
- Anti- water hammer function: can be set from 0 to 3 seconds through parameter P15.

2.2. Dimensions

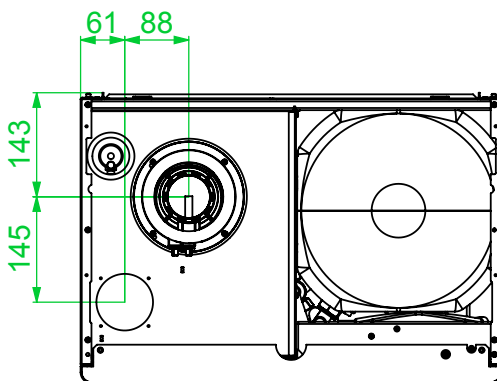
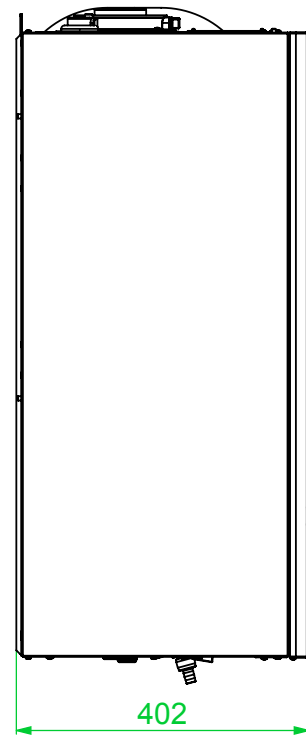
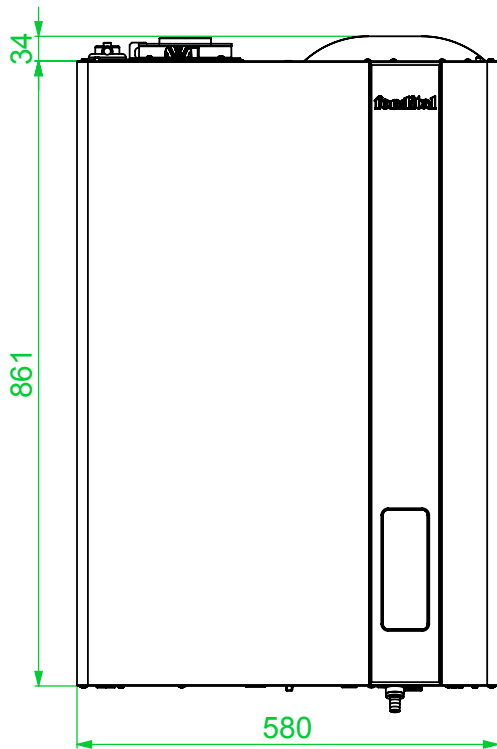
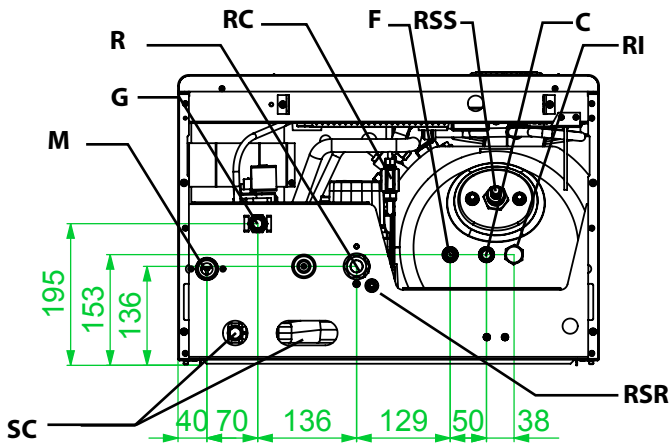

- M CH system flow (3/4")
- G Gas inlet (1/2")
- R CH system return (3/4")
- RC Filler cock
- RSR CH drain cock

- F Cold water inlet (1/2")
- C DHW outlet (1/2")
- RI DHW recirculation inlet (1/2")
- RSS DHW drain cock
- SC Condensate and safety valves drains

fig. 3

2.3. Key components

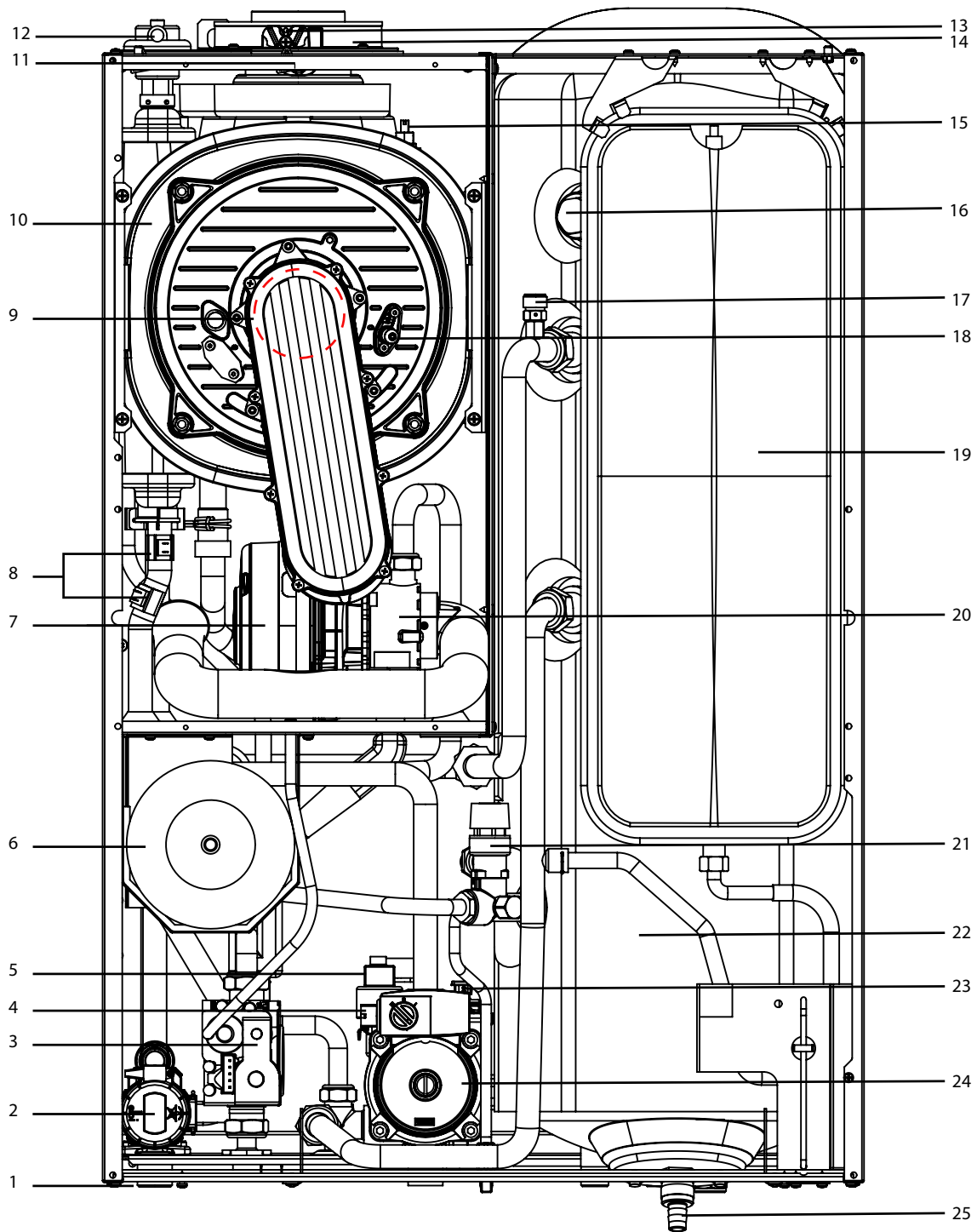

- |    |                                 |    |   |
|----|---------------------------------|----|---|
| 1  | Condensate trap inspection cap  | 14 | Air intake and flue gas venting tower   |
| 2  | Deviating valve motor           | 15 | Flue gas temperature probe on exchanger |
| 3  | Gas valve                       | 16 | Magnesium anode                         |
| 4  | Pressure transducer             | 17 | Coil bleed valve                        |
| 5  | CH safety valve                 | 18 | Ignition/flame detection electrode      |
| 6  | DHW expansion vessel            | 19 | CH expansion vessel                     |
| 7  | Combustion fan                  | 20 | Air/gas mixer                           |
| 8  | CH temperature probes           | 21 | DHW safety valve                        |
| 9  | Pre-mixed burner                | 22 | Stainless steel water heater            |
| 10 | Heat exchanger                  | 23 | CH air-purging device                   |
| 11 | Flue gas thermostat             | 24 | Circulation pump                        |
| 12 | Air-purging device on exchanger | 25 | Water heater drain cock                 |
| 13 | Flue gas/air analysis ports     |    |   |

fig. 4

## 2.4. Hydraulic layout

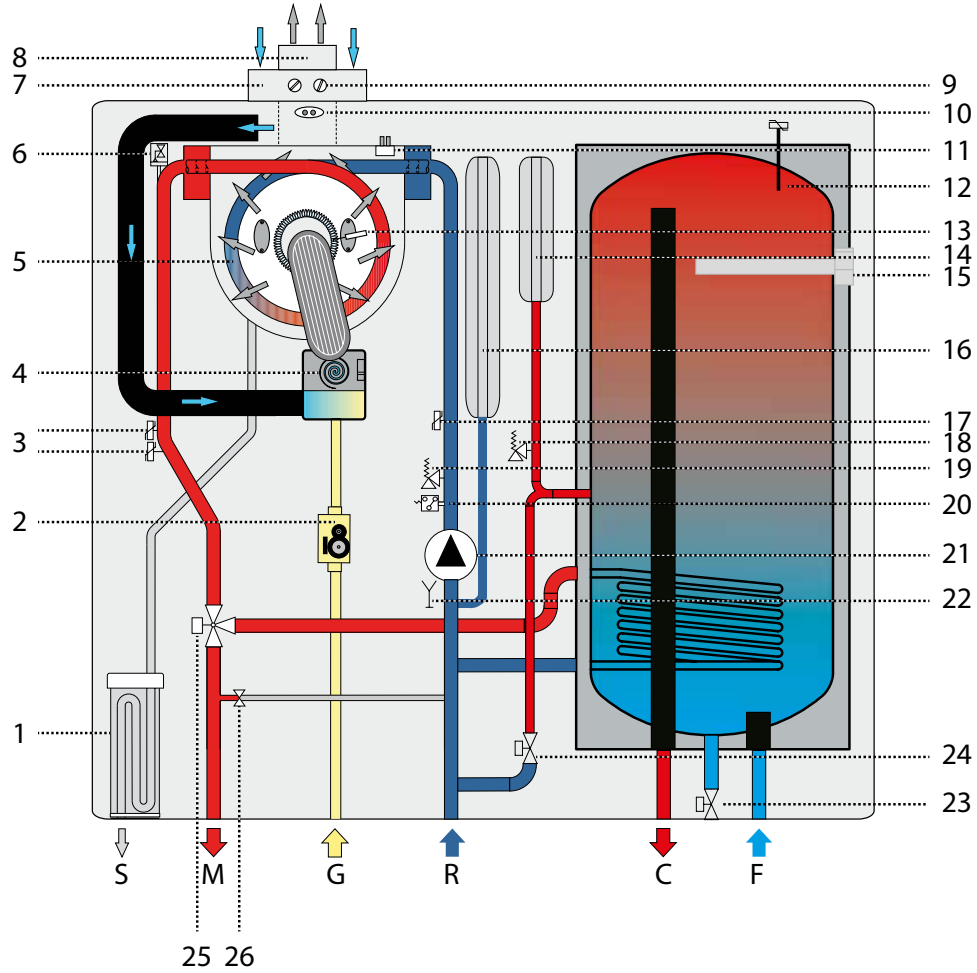

fig. 5

1. Condensate trap
2. Modulation gas valve
3. Flow temperature sensors
4. Modulating fan
5. Primary condensing exchanger
6. Air-purging device
7. Air intake duct
8. Flue gas venting duct
9. Flue gas analysis ports
10. Flue gas thermostat
11. Flue gas temperature probe on exchanger
12. Domestic hot water temperature sensor
13. Ignition/detection electrode
14. DHW expansion tank
15. Magnesium anode
16. CH expansion tank
17. Return temperature sensor

18. 7-bar DHW safety valve
19. 3-bar CH safety valve
20. Pressure transducer
21. Circulation pump
22. CH drain cock
23. Water heater drain cock
24. CH filler cock
25. Motorised 3-way valve
26. Automatic by-pass

- S Condensate drain  
 G Gas inlet  
 M CH flow  
 R CH return  
 C DHW outlet  
 F Cold water inlet

## 2.5. Operating data

Burner pressures reported in the following page must be verified after the boiler has been operating for 3 minutes.

### KB 24

Type of gas	CH max. heat input [kW]	CH heat output (80-60°C) [kW]		CH heat output (50-30°C) [kW]		DHW heat output [kW]		Gas mains pressure [mbar]	Nozzle [mm/100]	Diaphragm diameter [mm]	Flue gas CO <sub>2</sub> value [%]
		min.	max.	min.	max.	min.	max.				
Methane gas G20	23.7	2.7	22.8	3.2	25.0	2.7	26.8	20	3.7	-	9.0 ÷ 9.3
Propane Gas G31	23.7	2.7	22.8	3.2	25.0	2.7	26.8	37	3.0	-	10.0

Table 4 - Adjustment rates, KB 24

### KB 32

Type of gas	CH max. heat input [kW]	CH heat output (80-60°C) [kW]		CH heat output (50-30°C) [kW]		DHW heat output [kW]		Gas mains pressure [mbar]	Nozzle [mm/100]	Diaphragm diameter [mm]	Flue gas CO <sub>2</sub> value [%]
		min.	max.	min.	max.	min.	max.				
Methane gas G20	30.4	3.9	29.4	4.4	32.2	3.9	33.4	20	4.45	-	9.0 ÷ 9.3
Propane Gas G31	30.4	3.9	29.4	4.4	32.2	3.9	33.4	37	3.55	7.2	10.0

Table 5 - Adjustment rates, KB 32

## 2.6. General Characteristics

MODEL		KB 24	KB 32
Boiler category	-	I12H3P	I12H3P
CH min. pressure	bar	0.5	0.5
CH max. pressure	bar	3.0	3.0
DHW min. pressure	bar	0.5	0.5
DHW max. pressure	bar	6.0	6.0
DHW specific flow rate (Δt 30 K)	l/min	16.2	19.5
Electric power supply – voltage / frequency	V - Hz	230 - 50	230 - 50
Power mains supply fuse	A	3.15	3.15
Maximum power consumption	W	116	126
Electric protection rating	IP	X4D	X4D
Net weight	kg	61.50	69.00
Methane gas consumption at maximum CH output (*)	m <sup>3</sup> /h	2.51	3.22
Propane gas consumption at maximum CH output	kg/h	1.84	2.36
CH max. working temperature	°C	83	83
DHW max. working temperature	°C	65	65
CH expansion vessel total capacity	l	10	10
DHW expansion vessel total capacity	l	2	2
Maximum recommended system capacity (**)	l	200	200

Table 6 - General specifications

(\*) Value referred to 15°C - 1013 mbar

(\*\*) Maximum water temperature 83°C, expansion vessel pressure 1 bar

<b>KB 24</b>		<b>Max. output</b>	<b>Min. output</b>	<b>30% load</b>
Casing heat loss with burner on	%	0.97	6.49	-
Casing heat loss with burner off	%	0.28		
Flue system heat loss with burner on	%	2.62	2.09	-
Flue system mass capacity	g/s	12.43	1.33	-
Flue gas temp. – air temp.	°C	61	33	-
Heat output efficiency rating (60/80°C)	%	96.2	91.4	-
Heat output efficiency rating (30/50°C)	%	105.4	105.4	-
30% heat output efficiency rating	%	-	-	106.9
Efficiency rating (according to 92/42/EC)	-	★★★★		
NO <sub>x</sub> emission class	-	5		

Table 7 - Combustion specifications, KB 24

<b>KB 32</b>		<b>Max. output</b>	<b>Min. output</b>	<b>30% load</b>
Casing heat loss with burner on	%	0.99	5.06	-
Casing heat loss with burner off	%	0.22		
Flue system heat loss with burner on	%	2.61	2.04	-
Flue system mass capacity	g/s	15.81	1.87	-
Flue gas temp. – air temp.	°C	60	40.5	-
Heat output efficiency rating (60/80°C)	%	96.6	92.1	-
Heat output efficiency rating (30/50°C)	%	105.8	105.1	-
30% heat output efficiency rating	%	-	-	107.3
Efficiency rating (according to 92/42/EC)	-	★★★★		
NO <sub>x</sub> emission class	-	5		

Table 8 - Combustion specifications, KB 32

### 3. INSTRUCTIONS FOR THE INSTALLER

#### 3.1. Installation standards

This is an II2H3P category boiler and must be installed in compliance with the laws and standards in force in the country of installation, which are herein considered as entirely transcribed.

#### 3.2. Installation



**Accessories and spare parts for installation and service procedures are to be supplied by the Manufacturer. Should non original accessories and spare parts be employed, boiler proper performance is not guaranteed.**

##### 3.2.1. Packaging

The boiler is delivered packed in a robust cardboard box, fixed on a wooden pallet.

Remove boiler from cardboard box and check its integrity.

The packing materials can be recycled. Disposal must be managed via appropriate waste collection sites.

Keep packaging out of reach of children, as it may be dangerous.

The manufacturer shall not be held responsible in case of damage to people, animals, or property due to failure in following the above mentioned information.

Packaging includes:

- the hydraulic kit with copper pipes for boiler connection to gas mains, to the heating system and the DHW system;
- 2 shut-off cocks: one for gas and the other for cold water;
- two wall brackets;
- 2 double thread screws with relevant dowels and 4 M8 nuts to fix the two brackets to the wall;
- a silicon tube for CH safety valve drain
- a silicon tube and a fitting for DHW safety valve drain;
- a flue gas closing cap;
- a bag containing:
  - a) boiler installation, use and maintenance manual;
  - b) the paper template for mounting boiler on a wall (fig. 6);

##### 3.2.2. Choosing where to install the boiler

The following must be taken into account when choosing where to install the boiler:

- instructions from section 3.2.6. Air intake and flue gas venting system and relevant sub paragraphs;
- check the wall for sturdiness, avoiding weak areas;
- do not install the boiler over appliances which may affect boiler operation (e.g. cookers, which produce steam and grease, washing machines etc.);

##### 3.2.3. Positioning the boiler

Each boiler is supplied with a paper template (fig. 6igv), found inside the packaging.

The template allows you to ensure that the pipes connected to the central heating system, the domestic hot water system and the gas mains, and the air intake/flue gas venting pipes are all laid out correctly during the realisation of the water system and before installation of the boiler.

The template is made of heavy-duty paper, it is to be affixed to the wall where the boiler is to be mounted using a carpenter's level. It provides all the indications required to drill the boiler mounting holes to the wall, procedure which is done using two screws and wall blocks.

The lower area of the template shows where to mark the exact point at which the couplings are to be positioned for boiler connection to the gas supply pipe, cold water mains supply pipe, hot water outlet, CH flow and return pipes.

The upper area of the template shows where air intake and flue gas ducts are to be positioned.



**Since the temperature of the walls on which the boiler is mounted and external temperature of coaxial air/flue gas system do not exceed 60°C, no minimum distance from flammable walls is to be accounted for. For boilers with split air intake and flue gas venting ducts, in the case of proximity with flammable walls and passages through walls, apply insulating material between the wall and the flue gas venting pipe.**

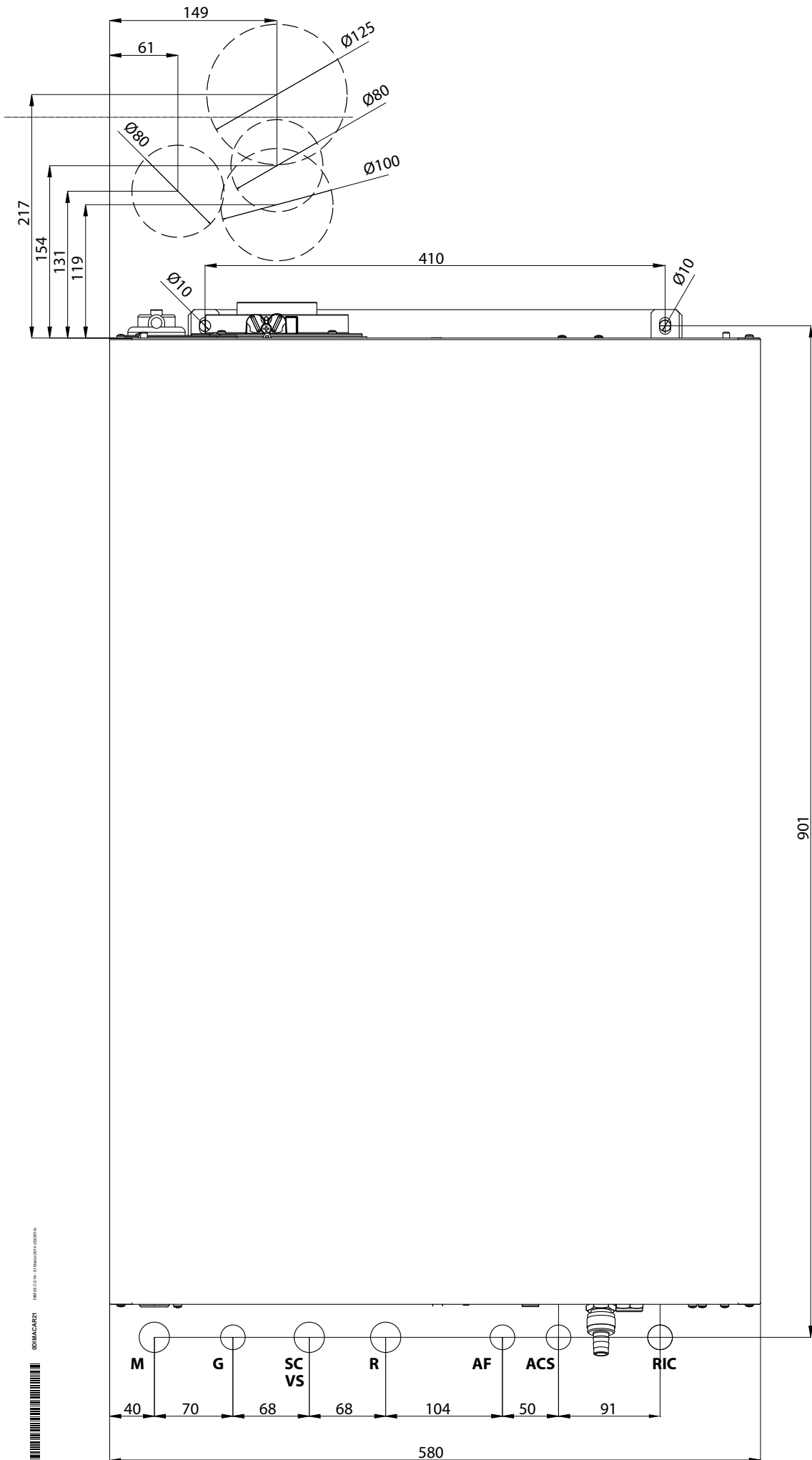

fig. 6



### 3.2.4. Installing the boiler



**Before connecting the boiler to CH and DHW networks, clean the pipes carefully.**

- Before commissioning a **NEW** system, clean it to remove any metal chips due to machining and welding, and any oil and grease that might negatively affect boiler operation or even damage it in case they get inside it.
- Before commissioning a **RECONDITIONED** system (where radiators have been added, the boiler has been replaced, etc.) thoroughly clean it to remove any sludge and residues.

**Clean the system using standard non acid products, available on the market.**

**Do not use solvents as they could damage system components.**

**Furthermore, in the central heating system (either new or reconditioned), it is always advisable to add to water a suitable percentage of corrosion protectants for multi-metal systems that will create a protective film onto all internal surfaces.**

**The manufacturer shall not be held responsible in case of damage to people, animals, or property due to failure to follow the above mentioned instructions.**



**For all boiler installation types, it is necessary to install a filter which can be inspected (Y-shaped type) with Ø 0.4mm-mesh, on the return pipe before the boiler.**

In order to install the boiler proceed as follows:

- secure the template (fig. 6) to the wall;
- drill two Ø 10 mm holes in the wall to accommodate the two boiler bracket wall blocks;
- if necessary, provide holes in the wall to allow air intake and/or flue gas venting pipes to pass through it;
- fix the two brackets to the wall carrying out in sequence the following steps:
  - screw the first two M8 nuts fully home inside the double thread screws;
  - screw in the screws fully home inside the wall blocks;
  - insert the brackets in the part of the screws that protrude from the wall;
  - screw the last two M8 nuts fully home inside the double thread screws;
- position the connections for the gas mains pipe (**G**), the cold water inlet pipe (**F**), the hot water outlet pipe (**C**), the flow (**M**) and return pipe (**R**) and the DHW recirculation if provided (**RI**), as indicated at the bottom of the template;
- provide a condensate drain and an outlet for the 3-bar and 7-bar safety valves;
- hook boiler to supporting brackets;
- connect the boiler to mains pipes by means of the coupling kit supplied with the boiler (refer to paragraphs 3.2.9. and 3.2.10);
- connect the boiler to pipe for condensate drain (refer to 3.2.9. paragraph);
- connect the boiler to the pipe for 3-bar and 7-bar safety valves drain, using the silicon tubes provided;
- connect the boiler to the air intake and flue gas venting system (see paragraphs 3.2.6. and 3.2.7. and relevant sub-paragraphs);
- connect electric power supply, ambient thermostat (when available) and other available accessories (refer to the following paragraphs).

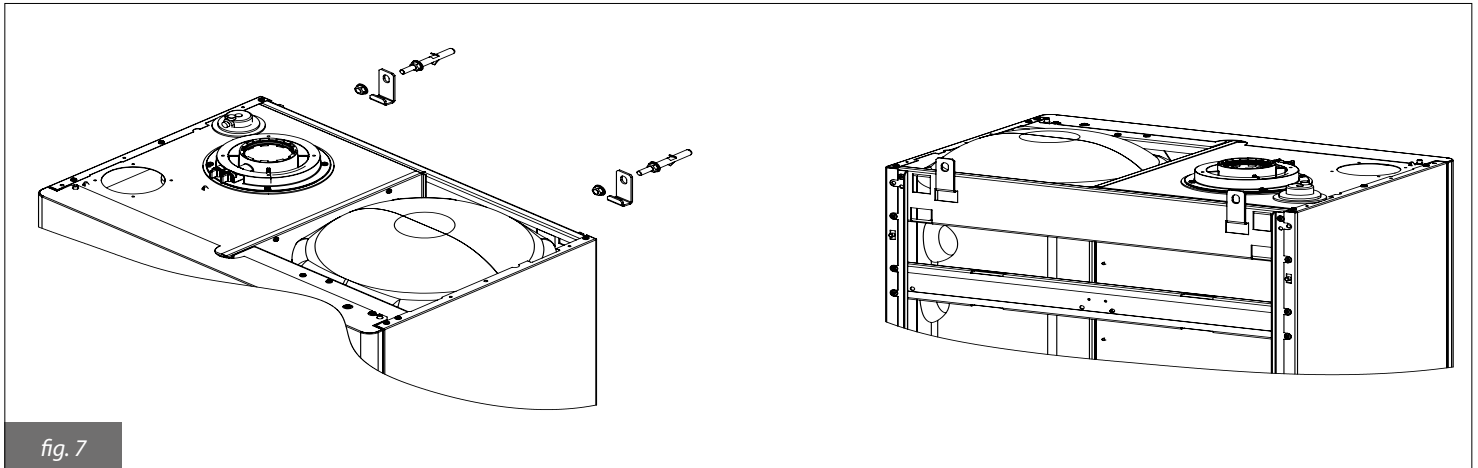

fig. 7

### 3.2.5. Boiler room ventilation

The boiler has sealed combustion chamber. Combustion air is not drawn from boiler room, therefore no specific recommendations need to be applied concerning the boiler room or openings and ventilation provided to the boiler room.



**The boiler must be installed in a room that is compliant with the legislation and standards in force in the country of installation, which are herein considered as entirely transcribed.**

### 3.2.6. Air intake and flue gas venting system

Flue gas discharge into the atmosphere and air intake/flue gas venting systems must comply with applicable laws and standards in the country of installation that are considered as fully transcribed herein.



The boiler is equipped with safety devices checking correct flue gas exhaustion.

Should an air/flue gas system malfunction occur, the safety devices will shut-down the boiler and the LCD will display the E03 code flashing.

It is strictly forbidden to tamper with and/or prevent operation of such safety devices.

Should the boiler repeatedly shut-down, it is necessary to have air/flue gas system ducts inspected, as they might be obstructed or inadequate to flue gas discharge into the atmosphere.



For the air intake/flue gas venting systems, specific, manufacturer approved, condensate acid-resistant pipes and systems must be used, suitable for condensing boilers.



Flue gas venting pipes are to be installed tilted toward the boiler so that condensate runs toward the combustion chamber, which is designed for condensate collection and drainage.

Should the above procedure not be possible, it is necessary to install, in condensate stagnation areas, devices designed for condensate collection and conveying to the condensate drain system.

It is necessary to avoid formation of condensate stagnation areas in the flue gas venting system, with the exception of the condensate trap possibly connected to the venting system itself.

The manufacturer cannot be held responsible for any damage caused by inappropriate boiler installation or operation, modification to the boiler, or due to non-observance of the instructions provided by the manufacturer or of legislation and standards applicable for the materials installed.

When positioning the boiler exhaust terminals onto the wall, comply with the distances specified in the applicable standards and regulations in force in the Country of installation, which are herein considered as entirely transcribed.

#### Installation examples

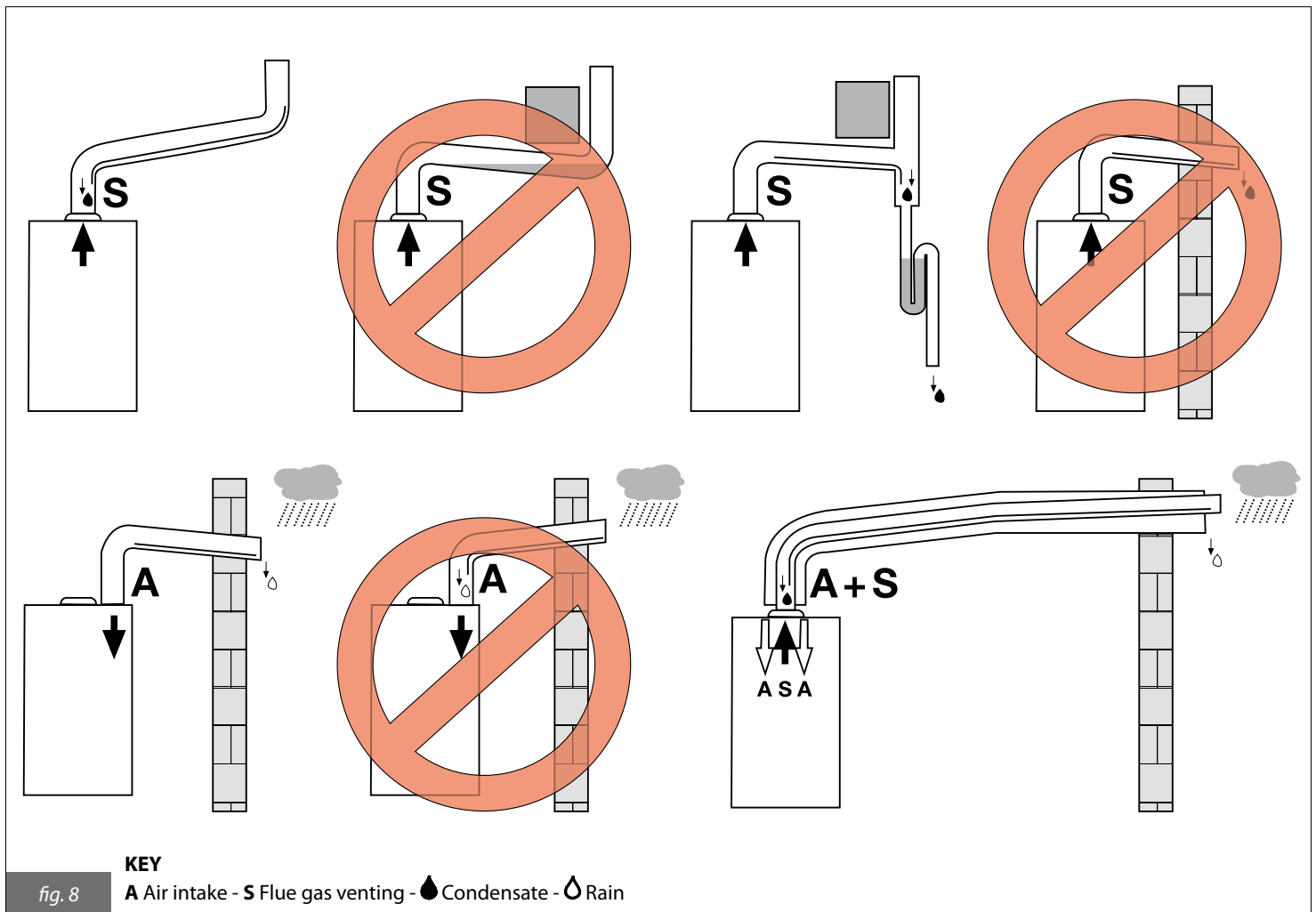

fig. 8

### 3.2.6.1. Configuration of air intake and flue gas venting ducts

#### **Type B23**

Boiler intended for connection to an existing flue system external to the boiler room. Combustion air is taken directly from the boiler room itself while flue gas is conveyed to the outside.

The boiler is not to be fitted with anti-wind gust device; it has to be equipped with a fan mounted before the combustion chamber/heat exchanger.

#### **Type B53**

Boiler intended for connection, via an independent duct, to the flue gas venting terminal. Combustion air is taken directly from the boiler room itself while flue gas is conveyed to the outside.

The boiler is not to be fitted with anti-wind gust device; it has to be equipped with a fan mounted before the combustion chamber/heat exchanger.

#### **Type C13**

Boiler intended for connection to horizontal outlet and intake ducts connected to the outside by means of coaxial or split ducts.

The minimum distance between the air intake duct and the flue gas venting duct must be at least 250 mm, whereas both terminals must be contained within a square measuring 500 x 500 mm.

The boiler is to be equipped with a fan mounted before the combustion chamber/heat exchanger.

#### **Type C33**

Boiler intended for connection to vertical outlet and intake ducts connected to the outside by means of coaxial or split ducts.

The minimum distance between the air intake duct and the flue gas venting duct must be at least 250 mm, whereas both terminals must be contained within a square measuring 500 x 500 mm.

The boiler is to be equipped with a fan mounted before the combustion chamber/heat exchanger.

#### **Type C43**

Boiler intended for connection to collective chimney pipe system that includes two ducts, air intake and flue gas exhaustion. These ducts may be coaxial or split.

The chimney must be compliant with applicable legislation and standards.

The boiler is to be equipped with a fan mounted before the combustion chamber/heat exchanger.

#### **Type C53**

Boiler with separate pipes for combustion air intake and flue gas evacuation.

These flues may discharge in areas at a different pressure.

The terminals may not face each other from opposed walls.

The boiler is to be equipped with a fan mounted before the combustion chamber/heat exchanger.

#### **Type C83**

Boiler intended to be connected to combustion air terminal and to a single flue gas terminal or collective chimney.

The chimney must be compliant with applicable legislation and standards.

The boiler is to be equipped with a fan mounted before the combustion chamber/heat exchanger.

### 3.2.6.2. Ø 100/60 mm and Ø 125/80 mm air/flue gas coaxial duct system

 The information given above is with reference to air intake/flue gas venting ducts made from smooth, rigid pipes approved and supplied by the manufacturer.

#### Type C13

##### KB 24

Minimum permissible length of horizontal coaxial pipes is 1 meter without accounting for the first elbow connected to the boiler.  
Maximum permissible length of Ø 100/60 mm horizontal coaxial pipes is 10 meters including the first elbow connected to the boiler.  
Maximum permissible length of Ø 125/80 mm horizontal coaxial pipes is 14.5 meters including the first elbow connected to the boiler.  
For each additional 1 meter of straight pipe maximum permissible length is to be reduced by 1 meter.  
For each additional 90° elbow, maximum permissible length is to be reduced by 1 meter.  
For each additional 45° elbow, maximum permissible length is to be reduced by 0.5 meter.  
The wall terminal reduces maximum permissible length by 1.5 meters.  
The air intake duct is to be tilted down by 1% toward its exit, in order to avoid rain water to enter it.

##### KB 32

Minimum permissible length of horizontal coaxial pipes is 1 meter without accounting for the first elbow connected to the boiler.  
Maximum permissible length of Ø 100/60 mm horizontal coaxial pipes is 7 meters including the first elbow connected to the boiler.  
Maximum permissible length of Ø 125/80 mm horizontal coaxial pipes is 10.5 meters including the first elbow connected to the boiler.  
For each additional 1 meter of straight pipe maximum permissible length is to be reduced by 1 meter.  
For each additional 90° elbow, maximum permissible length is to be reduced by 1 meter.  
For each additional 45° elbow, maximum permissible length is to be reduced by 0.5 meter.  
The wall terminal reduces maximum permissible length by 1.5 meters.  
The air intake duct is to be tilted down by 1% toward its exit, in order to avoid rain water to enter it.

#### Type C33

##### KB 24

Minimum permissible length of vertical coaxial pipes is 1 meter.  
Maximum permissible length of Ø 100/60 mm vertical coaxial pipes is 10 meters.  
Maximum permissible length of Ø 125/80 mm vertical coaxial pipes is 14.5 meters.  
For each additional 1 meter of straight pipe maximum permissible length is to be reduced by 1 meter.  
For each additional 90° elbow, maximum permissible length is to be reduced by 1 meter.  
For each additional 45° elbow, maximum permissible length is to be reduced by 0.5 meter.  
The roof vent terminal reduces maximum permissible length by 1.5 meters.

##### KB 32

Minimum permissible length of vertical coaxial pipes is 1 meter.  
Maximum permissible length of Ø 100/60 mm vertical coaxial pipes is 7 meters.  
Maximum permissible length of Ø 125/80 mm vertical coaxial pipes is 10.5 meters.  
For each additional 1 meter of straight pipe maximum permissible length is to be reduced by 1 meter.  
For each additional 90° elbow, maximum permissible length is to be reduced by 1 meter.  
For each additional 45° elbow, maximum permissible length is to be reduced by 0.5 meter.  
The roof vent terminal reduces maximum permissible length by 1.5 meters.

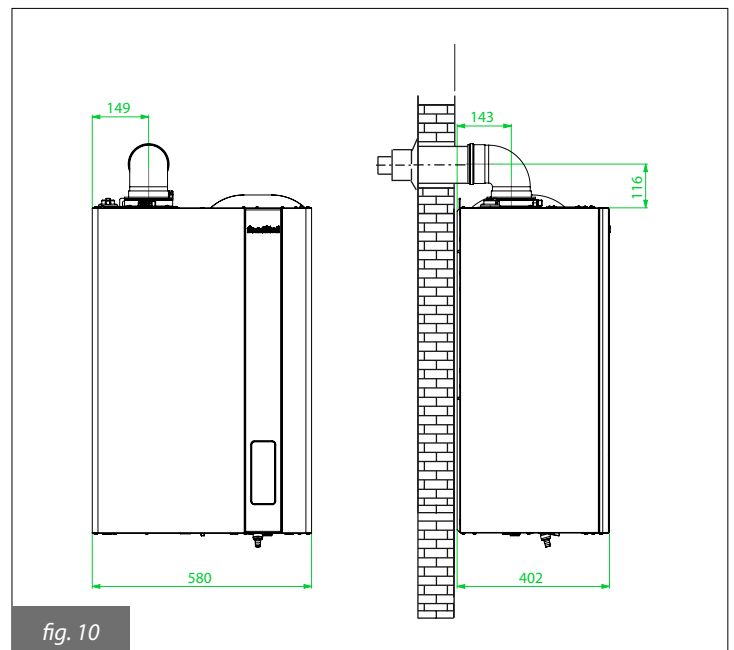
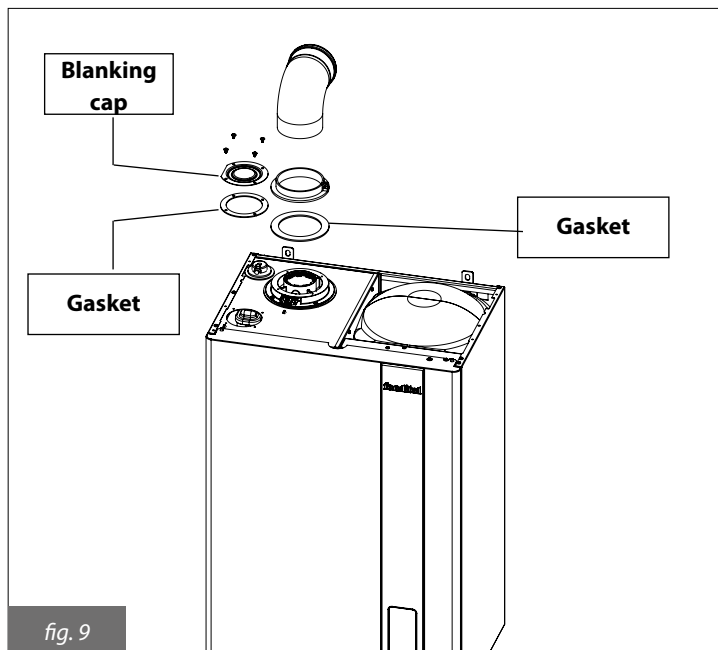

### 3.2.6.3. Air intake and flue gas venting via 80 mm split pipes

 The information given above is with reference to air intake/flue gas venting ducts made from smooth, rigid pipes approved and supplied by the manufacturer.

#### Installation types C43 - C53 - C83

##### KB 24

Minimum permissible length of air intake pipe is 1 meter.

Minimum permissible length of flue gas venting pipe is 1 meter.

Maximum permissible length of intake/flue gas venting pipes is 84 meters (combined length of air intake and flue gas venting pipe).

For each additional 1 meter of straight pipe maximum permissible length is to be reduced by 1 meter.

For each additional 90° elbow, maximum permissible length is to be reduced by 1 meter.

For each additional 45° elbow, maximum permissible length is to be reduced by 0.5 meter.

The roof terminal reduces maximum permissible length by 5.5 meters.

The wall terminal reduces maximum permissible length by 5 meters.

##### KB 32

Minimum permissible length of air intake pipe is 1 meter.

Minimum permissible length of flue gas venting pipe is 1 meter.

Maximum permissible length of intake/flue gas venting pipes is 78 meters (combined length of air intake and flue gas venting pipe).

For each additional 1 meter of straight pipe maximum permissible length is to be reduced by 1 meter.

For each additional 90° elbow, maximum permissible length is to be reduced by 1.5 meters.

For each additional 45° elbow, maximum permissible length is to be reduced by 1 meter.

The roof terminal reduces maximum permissible length by 6 meters.

The wall terminal reduces maximum permissible length by 5.5 meters.

### 3.2.6.4. Air intake and flue gas venting via 60 mm split pipes

#### Installation types C43 - C53 - C83

##### KB 24 - KB 32

Minimum permissible length of air intake pipe is 1 meter.

Minimum permissible length of flue gas venting pipe is 1 meter.

Maximum permissible length of intake/flue gas venting pipes is 23 meters for the KB 24 and of 20 meters for the KB 32 model (combined length of air intake and flue gas venting pipe).

For each additional 1 meter of straight pipe maximum permissible length is to be reduced by 1 meter.

For each additional 90° elbow, maximum permissible length is to be reduced by 1 meter.

For each additional 45° elbow, maximum permissible length is to be reduced by 0.5 meter.

The wall terminal reduces maximum permissible length by 4.5 meters.

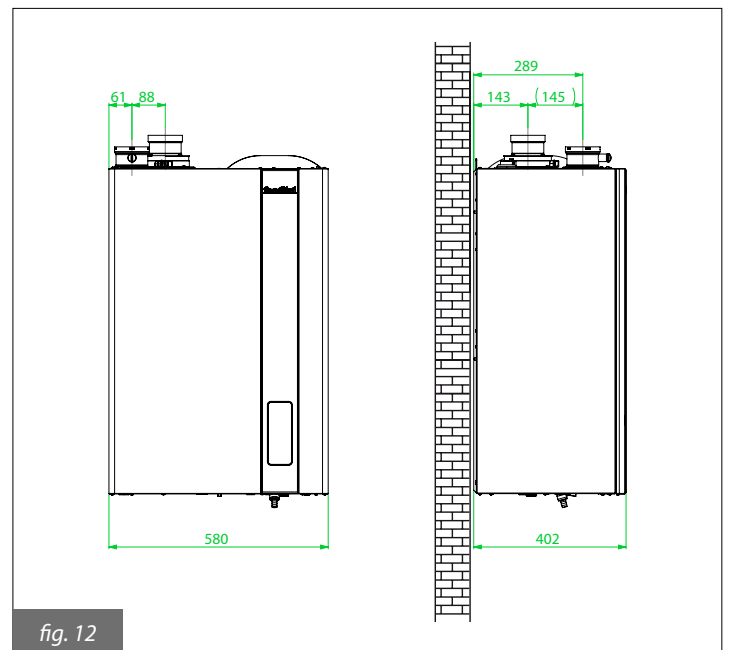
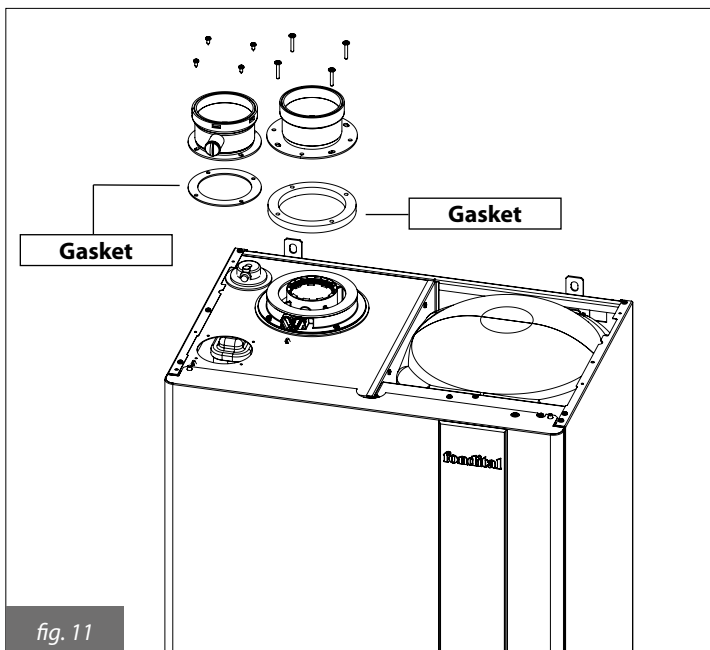

### 3.2.7. Checking combustion efficiency

#### 3.2.7.1. Flue cleaning function

The boiler features a flue cleaning function which must be used to measure combustion efficiency during operation and to adjust the burner.

To enable the flue cleaning function, press the "reset" key and keep it pressed for about three seconds. If the "reset" key is released before the three seconds have lapsed, the boiler continues to operate normally.

The "broom" symbol steady on and the fan speed indicate that the flue cleaning function is active.

The display shows the flow temperature and the lit flame on, if burner is on. The boiler performs the ignition sequence and then operates at the burner maximum output (parameter P4). The keys active in this function are: "reset" and "DHW +/-".

By pressing the "DHW +/-" keys it is possible to change the fan speed from P5 (minimum speed) to P4 (maximum speed). The display shows the wrench symbol (indicating that the parameter is being edited), the broom, the H letter (indicating Hertz), the speed set-point value in Hz, the fan current speed, and the lit flame on symbol if burner is on.

As soon as the "DHW +/-" key is released again, the display will show fan current rpm value, flow temperature, system pressure, the lit flame on symbol, the "broom" symbol to indicate that the flue cleaning function is active.

The flue cleaning function lasts 15 minutes. To quit this function, press "reset" and you will go back to the standard operating mode.

#### 3.2.7.2. Measurement procedure

The boiler is equipped with a tower allowing for air intake/flue gas venting pipe connection (fig. 13 and 14).

The tower is designed with two pre-arranged openings directly accessing air and flue gas ducts (fig. 13).

Remove caps A and B from the pre-arranged openings on the tower, before starting combustion checking procedure (fig. 13).

In order to verify combustion efficiency the following measurements must be implemented:

- assess combustion air from no. 1 opening (fig. 14);
- assess flue gas temperature and CO<sub>2</sub> from no. 2 opening (fig. 14).

Allow boiler to reach working temperature before taking any measurement.

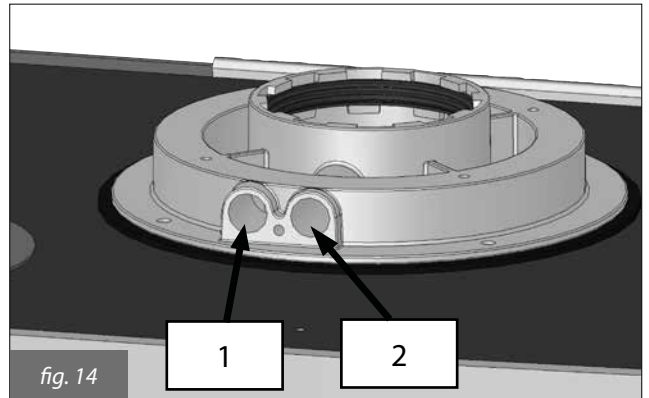
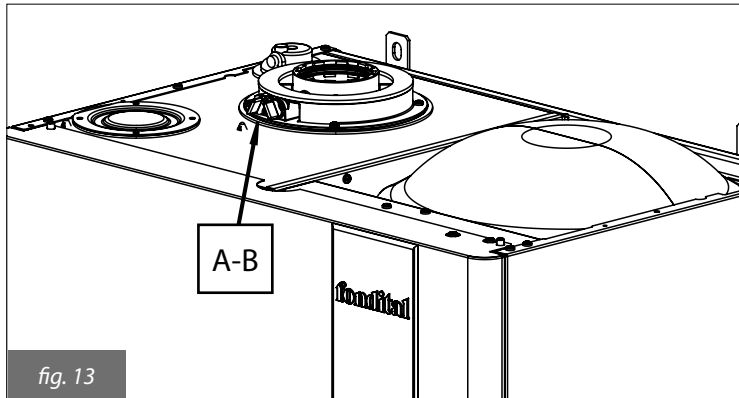

### 3.2.8. Connection to gas mains

Gas supply pipe cross-section must be equal or greater than boiler gas pipe.

Cross-section gas pipe size depends on its length, layout pattern, gas flow rate. Gas pipe size is to be selected accordingly.

Comply with installation standards enforced in the country where the boiler is installed which are considered as fully transcribed in this booklet.



**Remember that before operating an indoor gas distribution system and before connecting it to a meter, it must be checked for leaks. If some system parts are not visible, the leak test is to be carried out before the pipes are covered.**

**Leak test is NOT to be carried out employing flammable gas: use air or nitrogen for this purpose.**

**Once gas is in the pipes, leak test by a naked flame is forbidden; use specific products available on the market.**



**When connecting the boiler to gas supply network, it is COMPULSORY to install an appropriately sized gasket made from suitable material (fig. 15).**

**The boiler gas inlet coupling is NOT suitable for hemp, teflon tape or similarly made gaskets.**

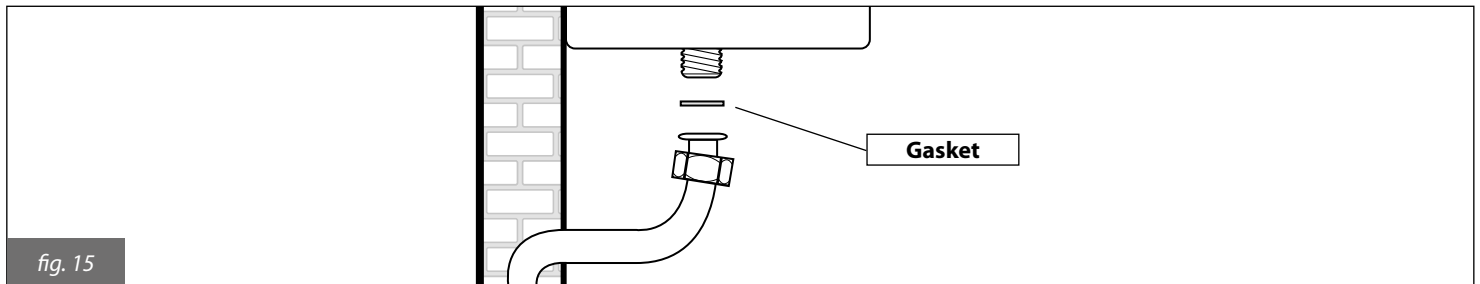

### 3.2.9. Hydraulic connections

Prior to installing the boiler, the hydraulic system is to be cleaned in order to remove impurities; they could be present in system components and damage the pump and the heat exchanger.

#### CH

The CH flow and return pipes must be connected to the respective 3/4" connectors **M** and **R** on the boiler (see pic. 6).

When calculating the cross section of CH system pipes, bear in mind load losses induced by radiators, thermostatic valves, radiator gate valves, and the configuration of the system itself.



**It is advisable to convey the discharge flow of boiler safety valves to the sewer system. Should the above precaution not be implemented and the safety valves be activated, boiler room flooding may occur.**

**Manufacturer shall not be held responsible for any damage resulting as failure in observing the above mentioned technical precaution.**

#### DHW

Cold water inlet and DHW outlet shall be connected to the boiler through the special 1/2" **C** and **F** fittings (pic. 6).

Hardness of water supplied to the boiler may increase water heater cleaning and /or replacement frequency.



**Depending on the hardness of the mains water supply, ascertain whether or not to install appropriate domestic water treatment systems using water treatment products suitable for drinking water and compliant with the standards in force in the country of installation.**

**Water treatment is always advisable when water supplied to the boiler is more than 20°F hard.**

**Water supplied by commonly marketed water softeners, due to PH level induced in water, may not be compatible with some components in the system.**

#### CONDENSATE DRAIN

Comply with condensate drain laws and standards applicable in the country of installation, which are considered herein integrally transcribed. If there are no particular restrictions, the condensate produced during combustion shall be conveyed (through the condensate drain) to a drain system allowing it to flow to the domestic sewer which, because of its basicity, contrasts the flue gas condensate acidity.

In order to avoid domestic sewer odour to reach the premises, it is advisable to install an appropriate device between the discharge system and the domestic sewer.

The condensate drain system and the domestic discharge system is to be made of an adequate, condensate-resistant material.

**The manufacturer shall not be held responsible in case of damage to people, animals, or property due to failure to follow the above mentioned instructions.**

### 3.2.10. Connection to electrical mains

The boiler is supplied with a three-poled power cable, already connected to the electronic board and it is provided with a safety clamp.

The boiler is to be connected to a 230V-50Hz electrical power supply.

**When connecting it to power mains, follow correct phase / neutral polarity sequence.**

Installation standards must be complied with and they are herein considered as entirely transcribed.

An easily accessible two-poled switch, with a minimum 3 mm distance between contacts, is to be installed ahead of the boiler. The switch is to allow power supply cut-off in order to safely perform maintenance and service procedures.

Power supply to the boiler must be fitted with a residual-current circuit breaker having suitable disconnection capacity. Electric power supply must be properly earthed.

The above mentioned safety measure must be verified. If in doubt, ask a qualified technician to thoroughly check the power network.



**The manufacturer cannot be held responsible for any damage caused by failure to earth the system correctly: gas, water, or CH system pipes are not suitable for grounding power networks.**

### 3.2.11. Selecting the operating range in CH mode

CH water temperature adjustment range depends on the selected operating range:

- **standard range:** 20°C to 78°C (press "CH + and -" keys on the display);

- **reduced range:** 20°C to 45°C (press "CH + and -" keys on the display).

The standard range is active with curves **P10**  $\geq 1$ , while the reduced range is active with curves **P10**  $< 1$ .

The two ranges can also be selected even with the external probe disconnected.

The waiting time between one boiler ignition and the following one, used to prevent boiler frequent turning on and off is 4 minutes for both ranges, and can be edited with the parameter P11.

If system water temperature decreases below a certain value, the waiting time is reset and the boiler re-ignited, as shown in the following table:

Selected range	Re-ignition temperature
Standard range	$< 40^{\circ}\text{C}$ (P27)
Reduced range	$< 20^{\circ}\text{C}$

Table 9 - Boiler re-ignition temperatures

Operation range selection is to be implemented by an installer or a qualified Service Centre.

### 3.2.12. Connection to ambient thermostat (optional)

The boiler is designed to be connected to an ambient thermostat (optional, not compulsory).

Ambient thermostat contacts must be properly sized in compliance with a load of 5 mA at 24 Vdc.

Ambient thermostat cables shall be connected to electronic board pins **1** and **2** (fig. 18), after having eliminated the jumper supplied as a standard with the boiler.

**The ambient thermostat cables are not to be grouped together in the same sheath as power mains supply cables.**

### 3.2.13. Installation and operation with Open Therm Remote Control (optional)

The boiler may be connected to an Open Therm Remote Control (non-compulsory optional accessory supplied by manufacturer).

**The Remote Control must only be installed by qualified personnel.**



**Only use original Remote Control Units supplied by the manufacturer. The correct operation of the Remote Control itself and of the boiler is not guaranteed if non original Remote Control units not supplied by the manufacturer are used.**

To install the Remote Control, refer to the instructions provided with the Remote Control itself.

Please note the following precautions when installing the Remote Control:

- **the remote control wiring must not be grouped together in the same sheath as the power cables:** if the cables are sheathed together, electrical interference from the power cables may compromise the functions of the Remote Control;

- the Remote Control must be installed on an indoor wall at a height of approximately 1.5 m from the floor and in a suitable location for measuring ambient temperature: do not install in recess or corners, behind doors or curtains, and install away from heat sources, direct sunlight, air draughts and water sprays.



The Remote Control connector is protected against inverted polarity, and the connections may be inverted.



**Do not connect the remote control to mains electrical power 230 V ~ 50 Hz.**

For complete instructions on how to program the Remote Control, refer to the instruction manual included in the Remote Control kit.

Board and Remote Control communicate in each operating mode: OFF, SUMMER, WINTER, CH ONLY; boiler display layout corresponds to the setting made from the Remote Control, as for the operating mode.

The Remote Control may be used to view and set a number of special parameters denominated TSP parameters and reserved solely for qualified technicians (tables 10 and 11).

TPS0 parameter sets default data table and restores all factory settings, cancelling all preceding modifications on single parameters.

If a single parameter is found to be incorrect, the value given in the default value table is restored.

If the user attempts to set a value not within the permissible range for the parameter, the new value is rejected and the existing value is maintained.

Parameter	Configurable value range	Default 24 kW methane gas	Default 24 kW propane gas	Default 32 kW methane gas	Default 32 kW propane gas
<b>P0 - TSP0</b> Equipment type and default data chart	1 - 7	1	3	6	7
<b>P4 - TSP4</b> Fan speed at burner maximum output (DHW)	From TSP5 ÷ 250 Hz	199 Hz	192 Hz	210 Hz	205 Hz
<b>P5 - TSP5</b> Fan speed at burner minimum power (DHW and heating)	25 ÷ 120 Hz	42 Hz	42 Hz	43 Hz	43 Hz
<b>P6 - TSP6</b> Fan speed at ignition power and propagation	25 ÷ 160 Hz	58 Hz	58 Hz	76 Hz	76 Hz
<b>P7 - TSP7</b> Upper limit for maximum CH output	10 ÷ 100 %	88%	88%	88%	88%
<b>P8 - TSP8</b> Negative ramp start minimum speed	TSP5 ÷ TSP6	56	56	60	60
<b>P10 - TSP10</b> Heating output curves	0 ÷ 3	1.5	1.5	1.5	1.5

Table 10 - Limits to be set for TSP parameters and default values in relation to boiler type (TSP0)

### 3.2.14. Installation of the (optional) external probe and sliding temperature operation

The boiler can be connected to an (optional) external temperature probe (optional, provided by the manufacturer) for sliding temperature operation.



**Only original external temperature probes supplied by the manufacturer must be used. If non-original external temperature probes are used, correct operation of the boiler and external probe cannot be guaranteed.**

The external temperature probe must be connected by means of a double insulated wire, minimum cross-section 0.35 sq.mm.

The external probe must be connected to pins 5-6 of boiler electronic board (fig. 18).

**The temperature probe cables must NOT be routed together with power cables.**

The temperature probe must be installed on an outside wall facing NORTH - NORTH EAST, in a position protected from weather.

Do not install near a window, ventilation openings or sources of heat.

The external temperature probe automatically modifies the CH flow temperature in relation to:

- the outdoor temperature measured;
- the thermoregulation curve selected;
- the calculated ambient temperature selected.

The calculated ambient temperature is set using "CH + and -" buttons (E, fig.1) that, with external probe installed, no longer work to set the heating water temperature (see paragraph 1.14.7.). Moreover the external temperature value detected by the external probe can be displayed through boiler P30 parameter.

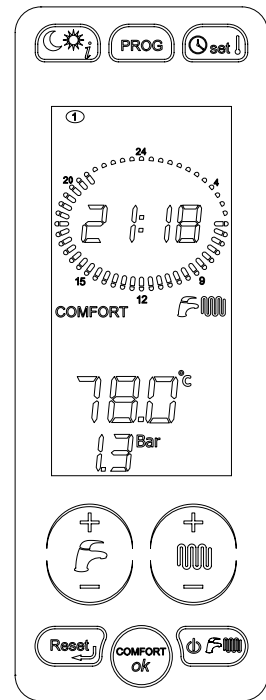
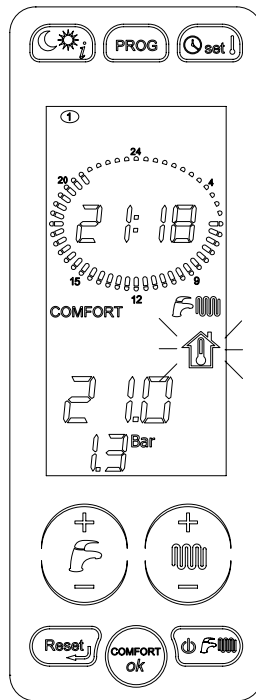
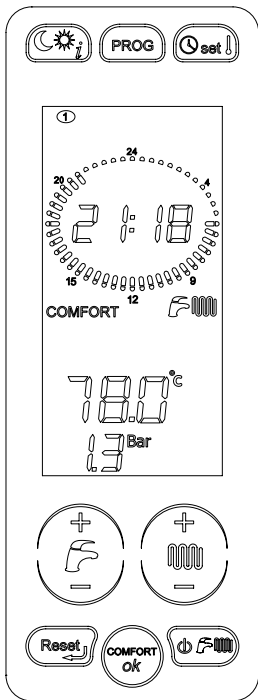

**1-** With installed external probe, press "CH + and -" buttons (E, fig. 1) to set calculated ambient temperature. As soon as "calculated ambient temperature" button is released, "calculated ambient temperature" icon will continue flashing for approx. 3 seconds, and the calculated ambient temperature value will flash as well.

**2-** After this time, value is stored and display standard operation will be restored.

Figure 16 shows the curves for a calculated ambient temperature of 20°C. Parameter **P10** allows selecting the curve value shown in pic. 16. If calculated ambient temperature value is edited on boiler display, the curves shift up or down, respectively, by the same amount. With a calculated ambient temperature setting of 20°C, for example, if you select the curve corresponding to parameter 1 and the outdoor temperature is -4°C, the CH flow temperature will be 50°C.

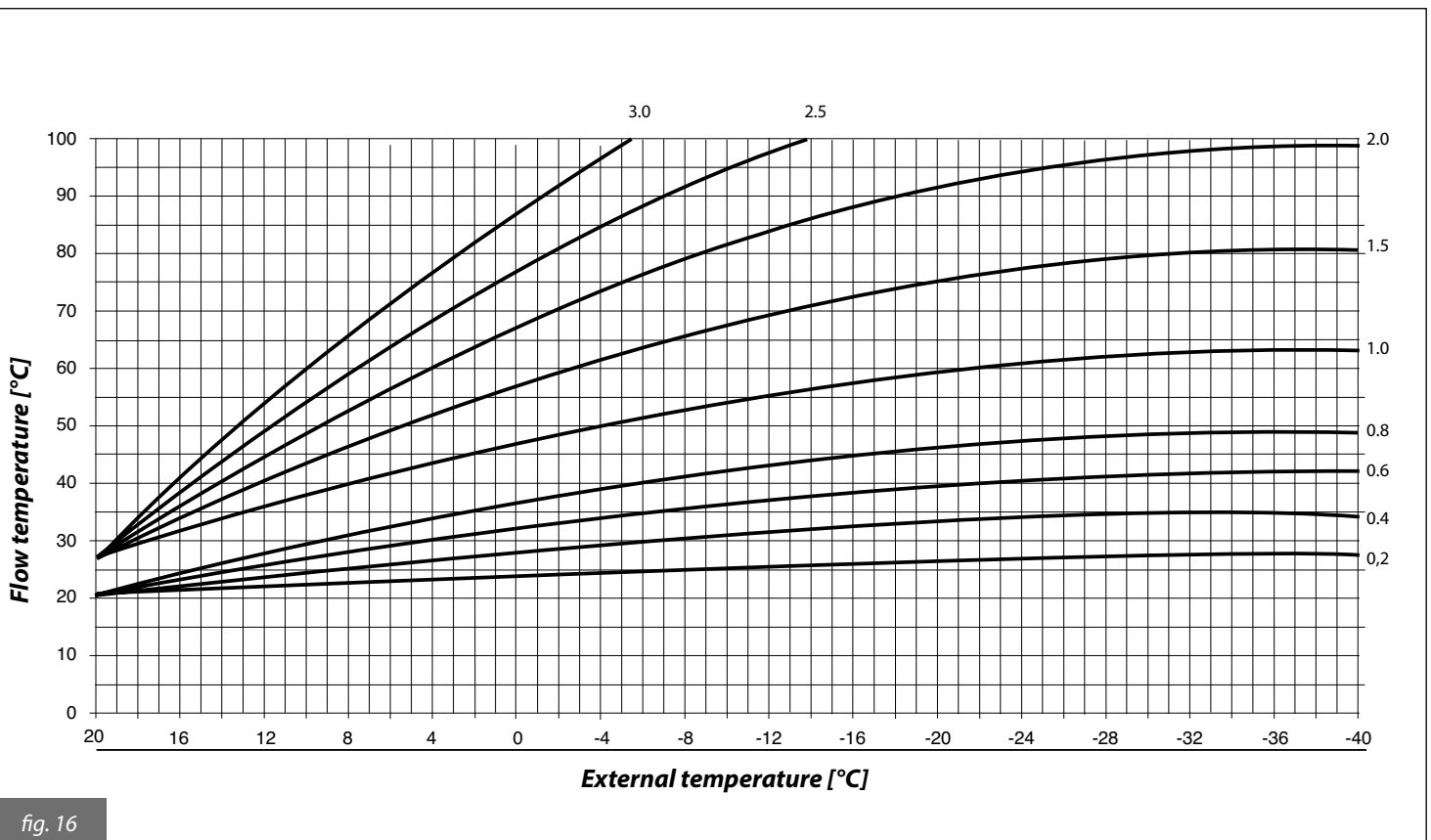

fig. 16

### 3.2.15. TSP parameters that can be set from interface or Remote Control

Parameter	Settable values	Default values	Notes
<b>P0 - TSP0</b> Boiler power selection	1, 3, 6, 7	According to the model	1 = 24 kW methane gas; 3 = 24 kW propane gas; 6 = 32 kW methane gas; 7 = 32 kW propane gas.
<b>P4 - TSP4</b> Fan speed at burner maximum output	P5 ÷ 250 Hz	According to the model	199 = 24 kW methane gas; 192 = 24 kW propane gas; 210 = 32 kW methane gas; 205 = 32 kW propane gas.
<b>P5 - TSP5</b> Fan speed at burner minimum output	25 ÷ 120 Hz	According to the model	42 = 24 kW; 43 = 32 kW
<b>P6 - TSP6</b> Fan speed at ignition power	25 ÷ 160 Hz	According to the model	58 = 24 kW; 76 = 32 kW
<b>P7 - TSP7</b> Fan speed at heating maximum output	10 ÷ 100%	88	
<b>P8 - TSP8</b> Negative ramp start minimum speed	P5 ÷ P6	According to the model	56 = 24 kW; 60 = 32 kW
<b>P9 - TSP9</b> Negative ramp time	0 ÷ 30 (1 = 10 sec.)	18 (180 sec.)	
<b>P10 - TSP10</b> Heating output curves	0 ÷ 3	1.5	
<b>P11 - TSP11</b> Heating thermostat timing	0 ÷ 10 min.	4	
<b>P12 - TSP12</b> CH power rising ramp timer	0 ÷ 10 min.	1	
<b>P13 - TSP13</b> Timer for CH post-circulation, freeze protection and flue cleaning function, configurable	30 ÷ 180 sec.	30	
<b>P15 - TSP15</b> Water hammer protection delay, configurable	0 ÷ 3 sec.	0	
<b>P16 - TSP16</b> Ambient thermostat reading delay / OT	0 ÷ 199 sec.	0	
<b>P17 - TSP17</b> Multifunction relay setting	0, 1, 3	0	0 = shut-down and fault, 1 = remote relay/TA1; 3 = request TA2
<b>P27 - TSP27</b> Heating timer reset temperature	20 ÷ 78 °C		P10 < 1 (low temp.) = 20 °C P10 > 1 (high temp.) = 40 °C
<b>P29 - TSP29</b> Setting of default parameters (except P0, P1, P2, P17)	0 ÷ 1	0	
Display only	<b>P30</b> External temperature		only with external probe connected
	<b>P31</b> Flow temperature		
	<b>P32</b> Nominal calculated flow temperature		only with external probe connected
	<b>P33</b> Set point of zone 2 flow temperature		only with at least one zone board connected
	<b>P34</b> Current zone 2 flow temperature		only with at least one zone board connected
	<b>P36</b> Set point of zone 3 flow temperature		only with at least two zone boards connected
	<b>P37</b> Current zone 3 flow temperature		only with at least two zone boards connected
	<b>P39</b> Set point of zone 4 flow temperature		only with three zone boards connected
	<b>P40</b> Current zone 4 flow temperature		only with three zone boards connected
	<b>P43</b> Boiler return temperature		
	<b>P44</b> Water heater temperature		
	<b>P45</b> Flue gas temperature		
	<b>P49</b> Ambient probe SA1 temperature		only with connected ambient probe
<b>P50</b> Ambient probe SA2 temperature		only with connected ambient probe	

<b>P51</b> SA1 ambient probe triggering differential OFF	0.0 ÷ 1.0 °C	0.0 °C	only with connected ambient probe	
<b>P52</b> SA1 ambient probe triggering differential ON	-1.0 ÷ -0.1 °C	-0.5 °C	only with connected ambient probe	
<b>P53</b> Ambient probe SA1 correction range	-5.0 ÷ 5.0 °C	0.0 °C	only with connected ambient probe	
<b>P54</b> SA2 ambient probe triggering differential OFF	0.0 ÷ 1.0 °C	0.0 °C	only with connected ambient probe	
<b>P55</b> SA2 ambient probe triggering differential ON	-1.0 ÷ -0.1 °C	-0.5 °C	only with connected ambient probe	
<b>P56</b> Ambient probe SA2 correction range	-5.0 ÷ 5.0 °C	0.0 °C	only with connected ambient probe	
<b>P57</b> Type of modulation with connected ambient probes (only with P61 set between 03 and 07)	0 ÷ 4	4	0 = on/off; 1 = ambient probe modulation; 2 = external probe modulation; 3 = ambient probe and external probe modulation; 4 = no ambient probe connected.	
<b>P58</b> Ambient probe weight during modulation	0 ÷ 20 °C	8 °C	used for thermoregulation with P57=3	
<b>P59</b> Type of temperature visualization on display	0, 1, 2, 3, 4	0	0 = flow temp.; 1 = probe SA1 temp.; 2 = probe SA2 temp.; 3 = external temp.; 4 = water heater temp.;	
<b>P60</b> Number of additional boards connected	0 ÷ 3	0	3 boards max.	
<b>P61</b> Association between remote and ambient thermostats	00 ÷ 07	00	00 = remote zone 2 / TA2 zone 1; 01 = TA1 zone 2 / TA2 zone 1; 02 = TA2 zone 2 / remote zone 1; 03 = SA1 zone 1 / TA2 zone 2; 04 = SA1 zone 1 / SA2 zone 2; 05 = remote zone 1 / SA2 zone 2; 06 = zone 1 not managed / SA2 zone 2; 07 = TA1 zone 1 / SA2 zone 2	
<b>P62</b> Selection of zone 2 curve	0 ÷ 3	0.6	only with zone board connected	
<b>P63</b> Zone 2 set-point	15 ÷ 35 °C	20 °C	only with zone board connected	
<b>P66</b> Selection of zone 3 curve	0 ÷ 3	0.6	only with two zone boards connected	
<b>P67</b> Zone 3 set-point	15 ÷ 35 °C	20 °C	only with two zone boards connected	
<b>P70</b> Selection of zone 4 curve	0 ÷ 3	0.6	only with three zone boards connected	
<b>P71</b> Zone 4 set-point	15 ÷ 35 °C	20 °C	only with three zone boards connected	
<b>P74</b> Low temperature zone mixer valve opening time	0 ÷ 300 sec.	140 sec.	only with zone boards connected	
<b>P75</b> Rise in nominal boiler temperature with zone board	0 ÷ 35 °C	5 °C	only with zone boards connected	
<b>P78</b> Interface back-lighting switching on	0 ÷ 2	0	0 = standard; 1 = LCD always on 2 = LCD and keys always on	
System check	<b>P80</b> Multifunction relay forcing	0 ÷ 1	0	0 = standard function; 1 = relay energised
	<b>P81</b> Zone 2 pump relay forcing	0 ÷ 1	0	0 = standard function; 1 = relay energised
	<b>P82</b> Zone 2 mixing valve forcing	0 ÷ 2	0	0 = standard function; 1 = force opening; 2 = force closing
	<b>P84</b> Zone 3 pump relay forcing	0 ÷ 1	0	0 = standard function; 1 = relay energised
	<b>P85</b> Zone 3 mixing valve forcing	0 ÷ 2	0	0 = standard function; 1 = force opening; 2 = force closing
	<b>P87</b> Zone 4 pump relay forcing	0 ÷ 1	0	0 = standard function; 1 = relay energised
	<b>P88</b> Zone 4 mixing valve forcing	0 ÷ 2	0	0 = standard function; 1 = force opening; 2 = force closing

Table 11 - General table of parameters

### 3.3. Filling the system

Once all boiler connections have been completed, CH system can be filled.

The procedure is to be cautiously carried out, following each step:

- open the air purging valves on all radiators and verify the boiler automatic valve operation;
- gradually open the relevant filler cock (fig. 2), checking any automatic bleeding valves installed in the system properly work;
- close all radiator air purging valves as soon as water starts coming out;
- check boiler water pressure gauge not to exceed 1÷1.3 bars reading;
- shut the filler cock and bleed any air out again, by opening the air bleeding valves on radiators;
- start the boiler and bring the system to working temperature, stop the pump, and repeat air bleeding procedure;
- allow the system to cool and restore water pressure to 1÷1.3 bars.

#### WARNING

**As for water treating in the domestic heating systems in order to optimise efficiency and safety, ensure a long life, trouble-free operation of auxiliary equipment, minimise power consumption, thereby integrating the standards and rules in force in the country of installation, it is recommended to use specific products suitable for multi-metal heating systems.**

#### WARNING

**Pressure sensor will not electrically enable the burner ignition when water pressure is below 0.4 bar (this parameter can be edited by qualified professional staff).**

**CH water pressure must not to be less than 1 bar. Restore proper value as needed, via the filler cock of the boiler (fig. 2).**

**The procedure is to be followed while the system is cold. Digital pressure gauge is used to read pressure inside the heating circuit.**

#### WARNING

**After long inactivity of the boiler, its pump may be stuck. Before starting up the boiler, make sure that the pump is operating, with the following procedure:**

- unscrew the protective cap at the centre of the pump motor;
- put a screwdriver into the hole and manually rotate the circulation pump shaft clockwise;
- once the unblocking operation is completed, screw the protective cap back on and check for water leaks.

**When the protection cap is removed, some water may flow out. Before refitting the boiler casing ensure that all surfaces are properly dried.**

#### ATTENZIONE

**Dopo un certo periodo di inattività della caldaia la pompa potrebbe essere bloccata. Prima di effettuare l'accensione della caldaia si deve avere l'accortezza di effettuare l'operazione di sbloccaggio della pompa operando come di seguito indicato:**

- svitare la vite di protezione collocata al centro del motore della pompa;
- introdurre un cacciavite nel foro e quindi ruotare manualmente l'albero del circolatore in senso orario;
- una volta conclusa l'operazione di sbloccaggio riavvitare la vite di protezione e verificare che non vi siano perdite di acqua.

**Rimossa la vite di protezione si potrà avere la fuoriuscita di un po' di acqua. Prima di rimontare il mantello della caldaia provvedere ad asciugare le superfici bagnate.**

### 3.4. Starting up the boiler

#### 3.4.1. Preliminary checks

Before starting the boiler, check that:

- the flue gas venting duct and the relevant terminal are installed in conformity with the instructions: **with the boiler operating, there must be no leakage of combustion by-products from any of the gaskets;**
- the supply power to the boiler must be 230 V – 50 Hz;
- the system is correctly filled with water (pressure gauge reading 1 to 1.3 bar);
- any shut-off cocks in the system pipes are open;
- the mains gas type is correct for the boiler calibration: convert the boiler to the available gas if necessary (see section 3.7. Adaptation to other gas types): have this operation carried out by qualified technical personnel;
- the gas supply cock is open;
- there are no fuel gas leaks;
- the main switch installed ahead of the boiler is turned on;
- 3-bar and 7-bar safety valves are not blocked;
- there are no water leaks;
- the pump has not seized.
- the condensate trap installed on the boiler is discharging condensate correctly and is not stuck.

#### WARNING

**The boiler is equipped with a 3-speed circulation pump, set by the manufacturer on speed III.**

**Figure 17 shows the system residual heads for the various speeds.**

**If you wish to set a different speed, taking into account the water circulation requirements in the boiler and the resistance properties of the system, check operation of the boiler in all the conditions dictated by the features of the system (e.g. closure of one or more heating zones or of thermostat-controlled valves).**

#### 3.4.2. Switching on and switching off

To switch the boiler on and off, refer to the "**Instructions for the User**".

3.5. Available head to the system

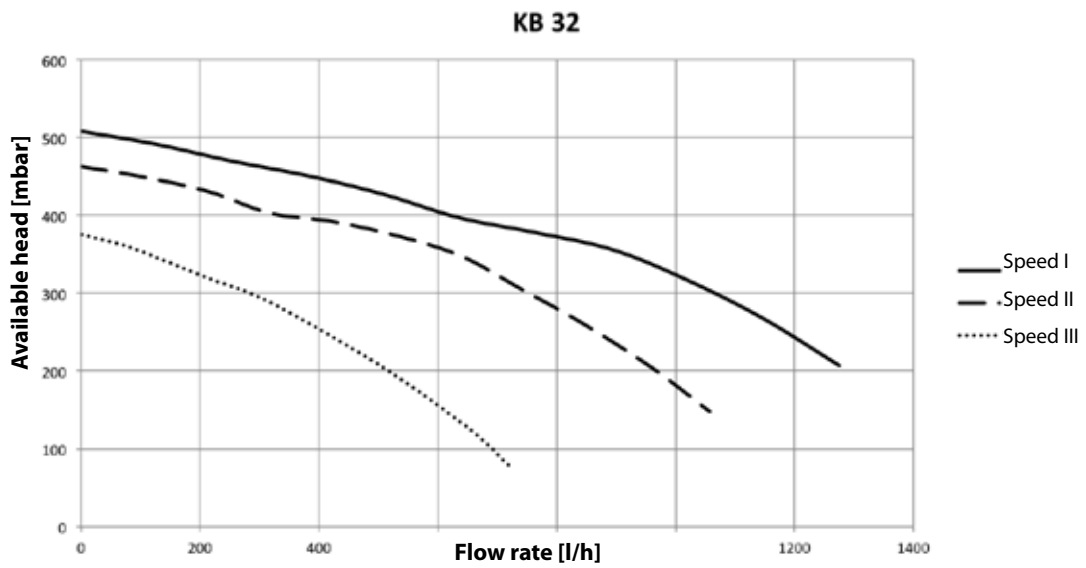
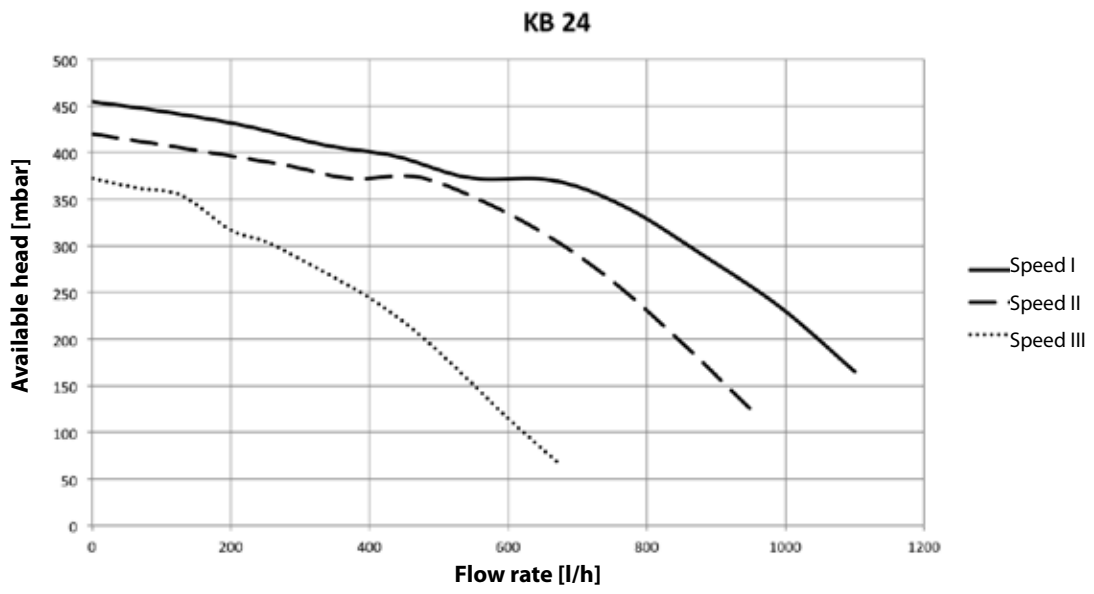

fig. 17

### 3.6. Wiring diagram

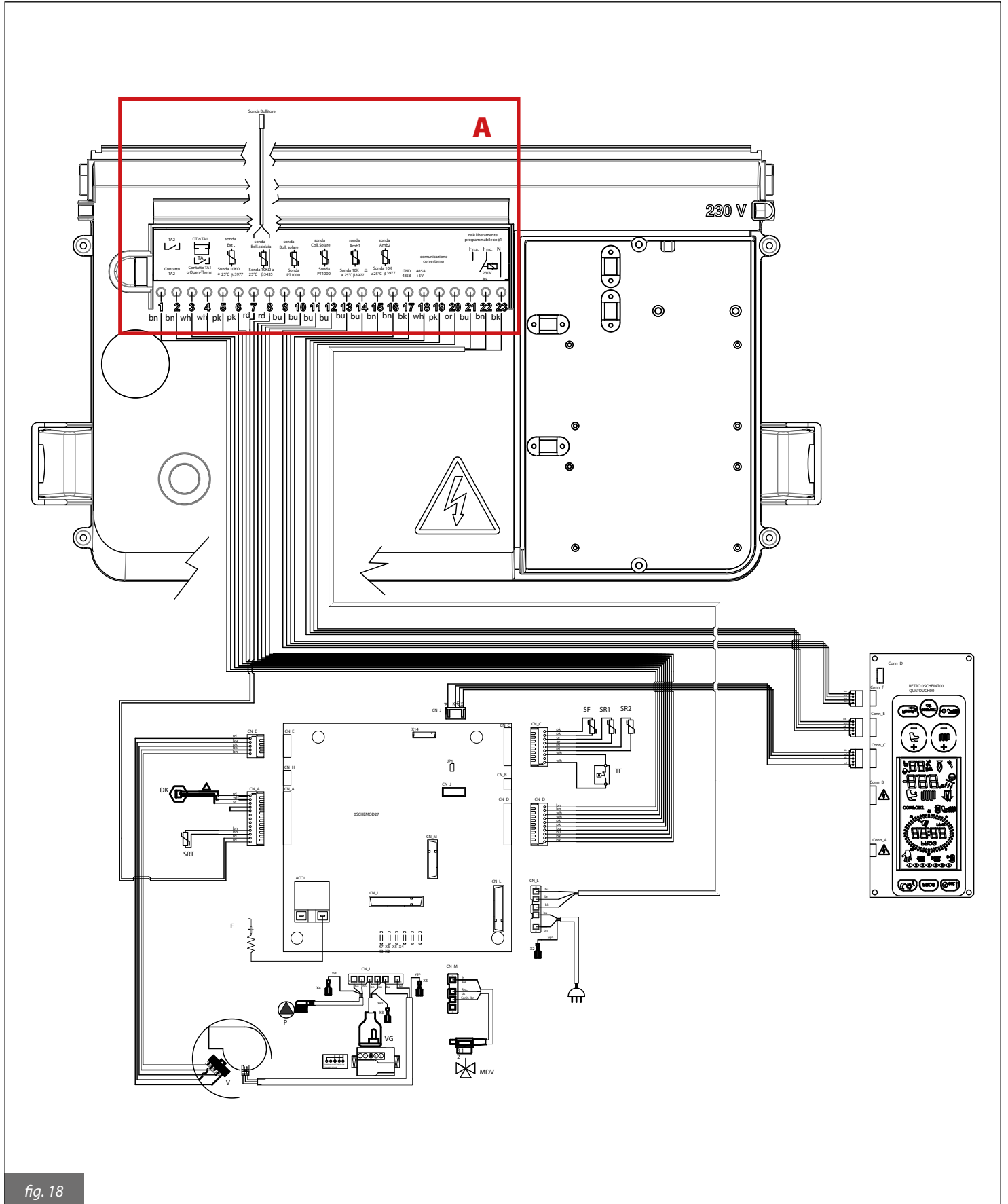
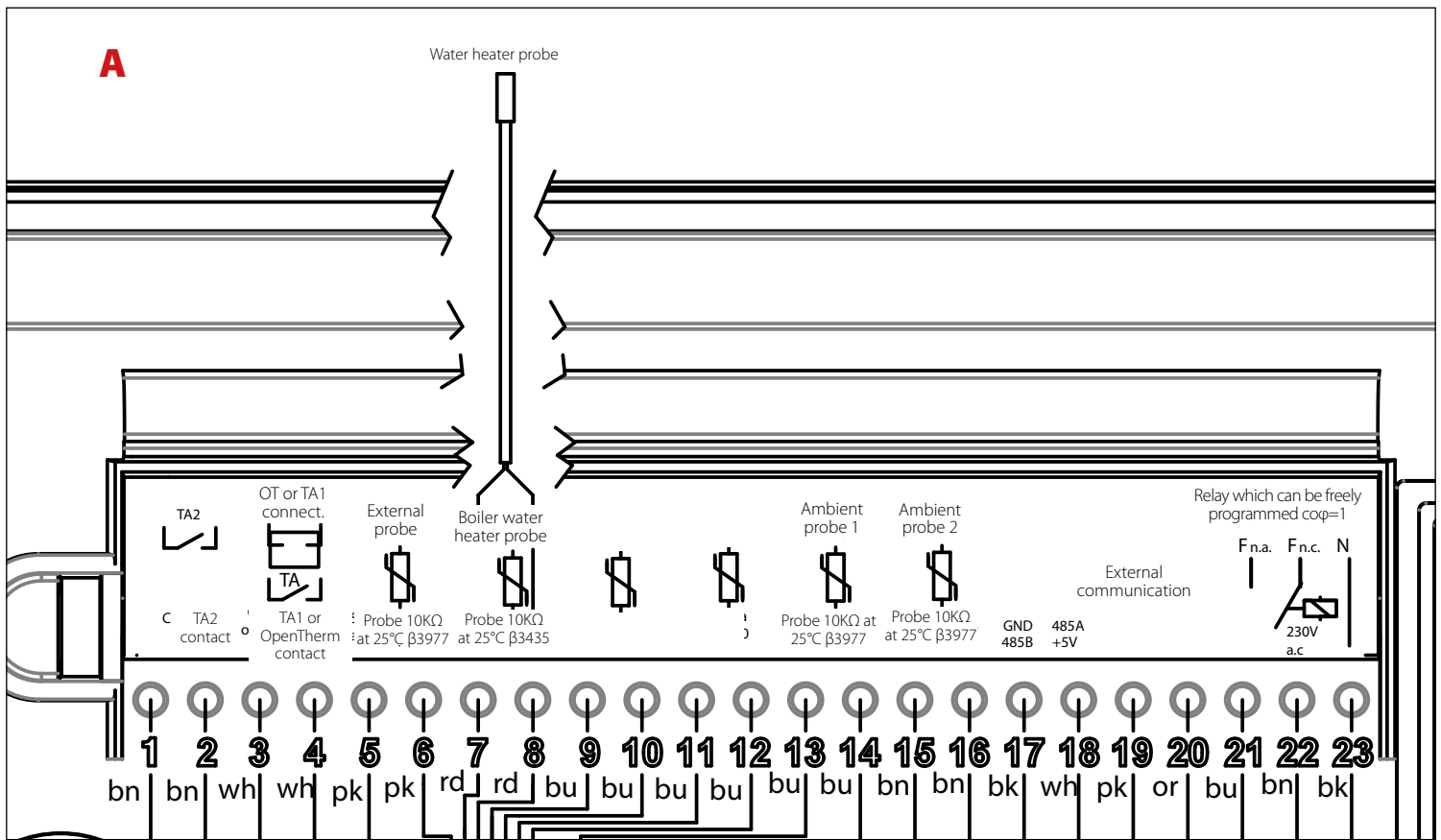

fig. 18



**Internal connections:**

- DK: ANALOGUE WATER TRANSDUCER
- SS: DHW NTC PROBE 10 K Ohm at 25°C B=3435
- SRT: RETURN NTC PROBE 10 K Ohm at 25°C B=3435
- SR1-SR2: CH NTC PROBE 10 K Ohm at 25°C B=3435
- SF: FLUE GAS PROBE
- TF: FLUE GAS THERMOSTAT
- VG: GAS VALVE
- P: BOILER CIRCULATION PUMP
- MVD: ELECTRIC DEVIATING VALVE
- E: IGNITION/FLAME DETECTION ELECTRODE
- V: BRUSHLESS FAN
- OSCHEMOD27: ELECTRONIC BOARD
- OQUATOUCH00: CONDENSING BOILER USER INTERFACE
- CN\_A-CN\_M: LOAD/SIGNAL CONNECTORS
- X2-X7: GROUND CONNECTORS

**3.6.1. Multifunction relay connecting diagram**

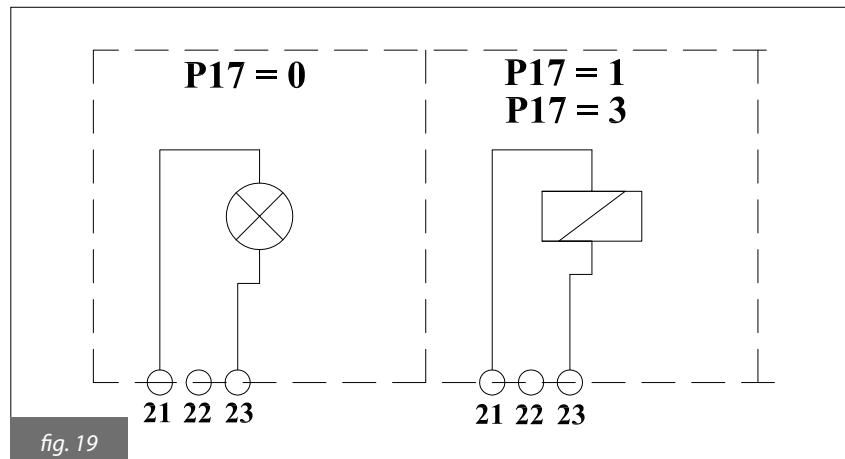
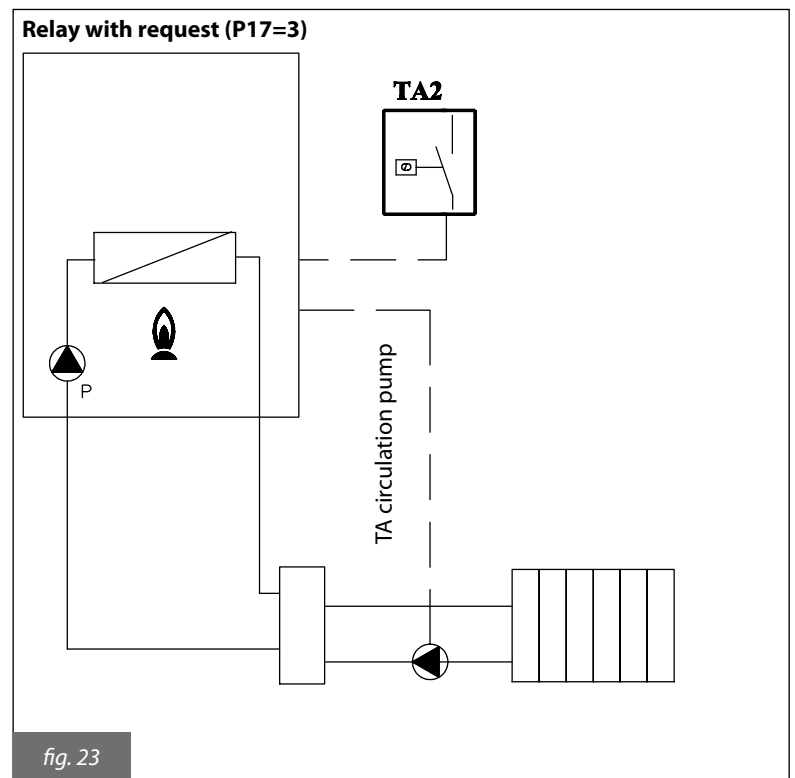
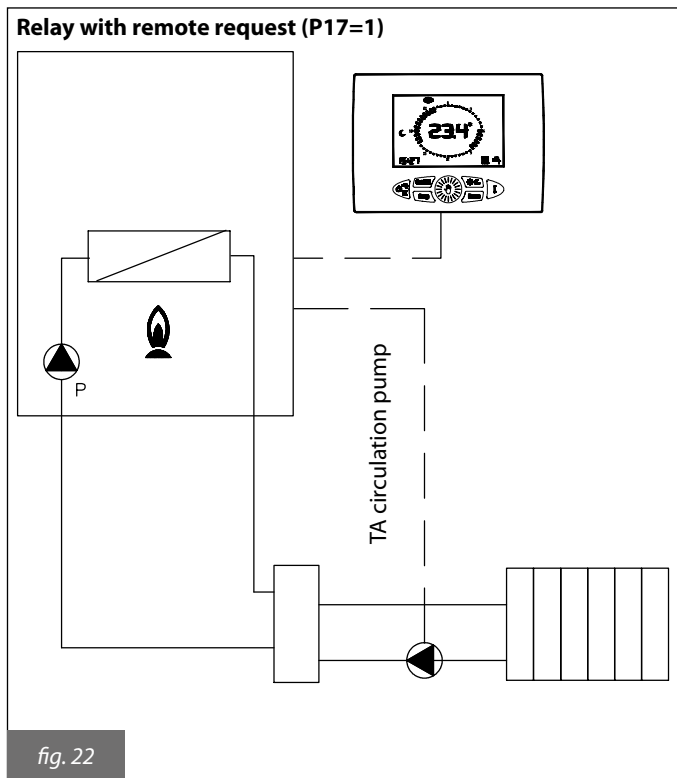
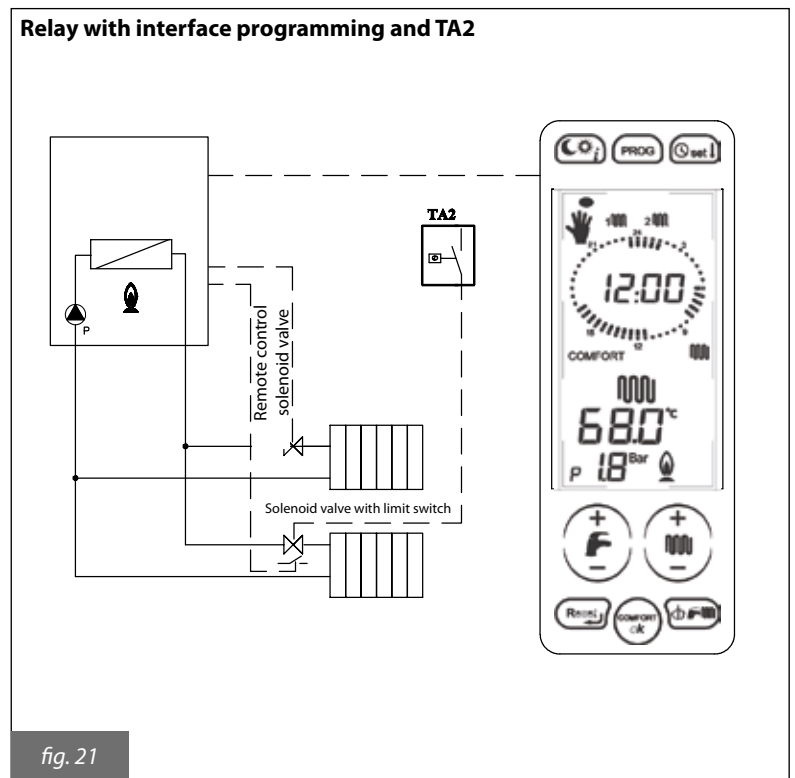
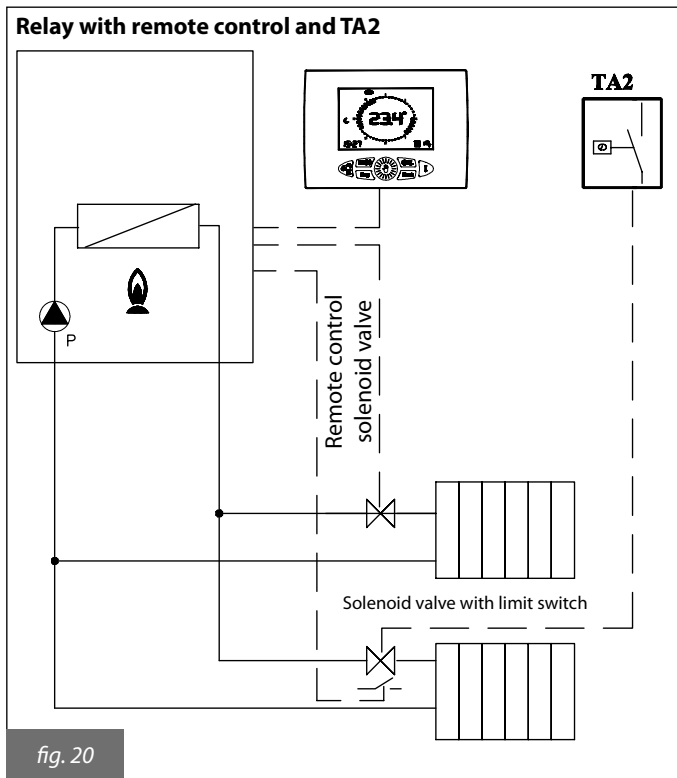

fig. 19



### 3.6.2. Multifunction relay setting diagrams

The control panel features a multifunction relay, to be set through the parameter P17 - TSP17



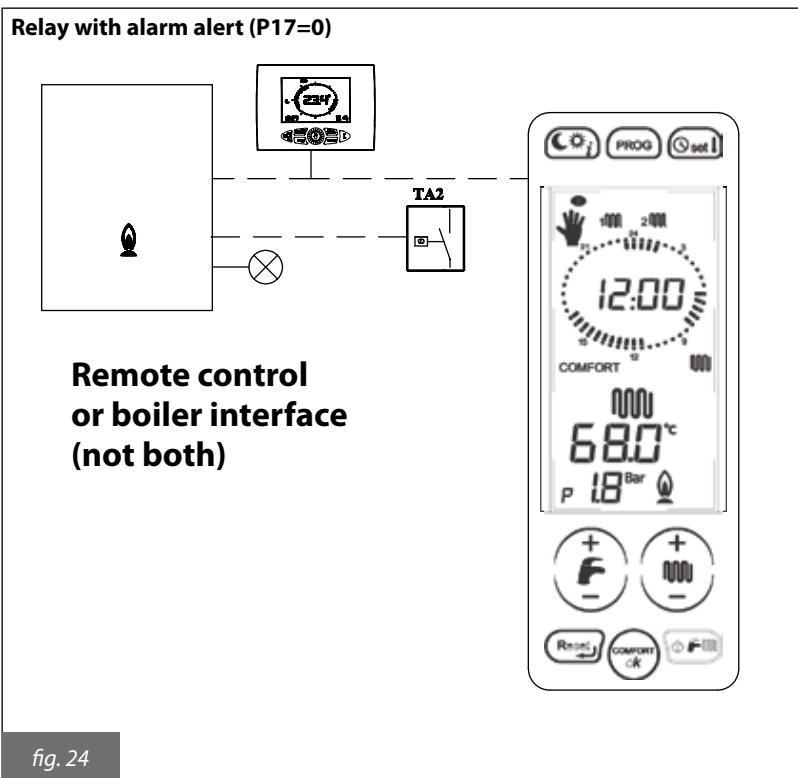

DIAGRAM PARAMETER SETTING	
	P17
Error signalling relay	0
Relay controlled by TA1 or by the remote control	1
Relay controlled by TA2 or by the interface	3

**Relationship between temperature (°C) and nominal resistance (Ohm) of all NTC probes.**

T (°C)	0	2	4	6	8
0	27203	24979	22959	21122	19451
10	17928	16539	15271	14113	13054
20	12084	11196	10382	9634	8948
30	8317	7736	7202	6709	6254
40	5835	5448	5090	4758	4452
50	4168	3904	3660	3433	3222
60	3026	2844	2674	2516	2369
70	2232	2104	1984	1872	1767
80	1670	1578	1492	1412	1336
90	1266	1199	1137	1079	1023

Table 12 - Relationship between "Temperature and Nominal resistance" for temperature probes

### 3.7. Adaptation to other gas types and burner adjustment



**This boiler is built to run on the type of gas specified on the order, which is shown on the packaging and on the boiler rating plate. Any later transformation is to be exclusively carried out by qualified personnel, using manufacturer designed accessories and following the procedure and adjustment instructions for an accurate boiler setting-up.**

#### 3.7.1. Switching from Methane gas to Propane gas

- Disconnect the boiler from the electric power supply.
- Remove boiler outer front panel.
- Loosen the three screws securing combustion chamber front panel to frame, then remove panel.
- Loosen the screw securing intake pipe to mixer, and remove pipe (fig. 25).
- Disconnect gas pipe from mixer (fig. 25).
- Loosen the three socket head screws, and remove the mixer (fig. 26).
- Loosen the two retaining screws, and slide out mixer plastic body (fig. 27).
- Using a 6 mm Allen wrench, loosen the two mixer nozzles (fig. 27).
- Screw the new nozzles for propane listed in tab. 14, **taking care to drive them fully home, without tightening.**
- Only for the KB 32 model, insert the 7.2 mm diaphragm on the outlet of the gas valve.



**In case the nozzle idles when reaching the bottom of the nozzle threaded seat, it means that the thread is damaged and perfect sealing is not ensured. The whole mixer shall be replaced.**

- To refit the plastic body (Venturi), insert it inside mixer and secure it in place with the retaining screws. **Take care not to damage the O-rings assembled on plastic body ends (fig. 27) and to respect the assembling direction (fig. 28).**
- Refit the reassembled mixer onto the fan with the socket head screws, making sure to insert the O-ring between mixer and fan (fig. 27).
- Reconnect boiler to electric power supply, and open the gas cock.
- Access the programming page to set the parameters P0-P4-P5-P6-P8 to the propane gas values, as described in tab. 10.
- Adjust the gas valve (see next paragraph, 3.7.3.).

#### 3.7.2. Switching from Propane gas to Methane gas

- Disconnect the boiler from the electric power supply.
- Remove boiler outer front panel.
- Loosen the three screws securing combustion chamber front panel to frame, then remove panel.
- Loosen the screw securing intake pipe to mixer, and remove pipe (fig. 25).
- Disconnect gas pipe from mixer (fig. 25).
- Loosen the three socket head screws, and remove the mixer (fig. 26).
- Loosen the two retaining screws, and slide out mixer plastic body (fig. 27).
- Using a 6 mm Allen wrench, loosen the two mixer nozzles (fig. 27).
- Screw the new nozzles for methane listed in tab. 14, **taking care to drive them fully home, without tightening.**
- Only for the KB 32 model, remove the 7.2 mm diaphragm on the outlet of the gas valve.



**In case the nozzle idles when reaching the bottom of the nozzle threaded seat, it means that the thread is damaged and perfect sealing is not ensured. The whole mixer shall be replaced.**

- To refit the plastic body (Venturi), insert it inside mixer and secure it in place with the retaining screws. **Take care not to damage the O-rings assembled on plastic body ends (fig. 27) and to respect the assembling direction (fig. 28).**
- Refit the reassembled mixer onto the fan with the socket head screws, making sure to insert the O-ring between mixer and fan (fig. 27).
- Reconnect boiler to electric power supply, and open the gas cock.
- Access the programming page to set the parameters P0-P4-P5-P6-P8 to the propane gas values, as described in tab. 10.
- Adjust the gas valve (see next paragraph, 3.7.3.).

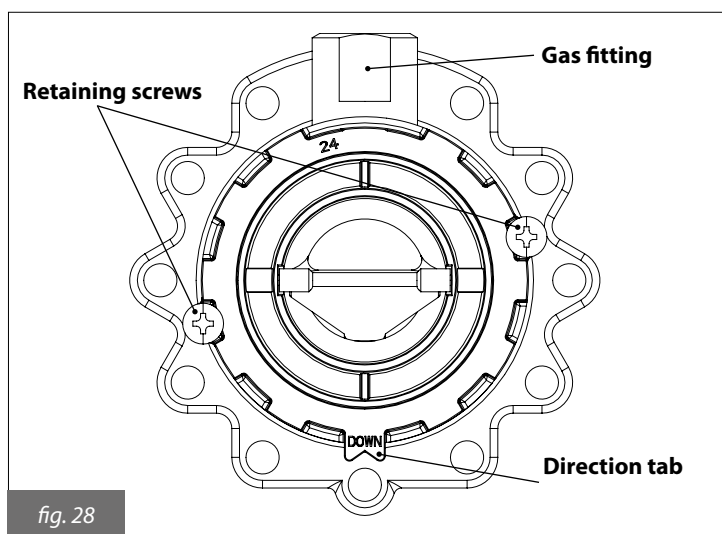
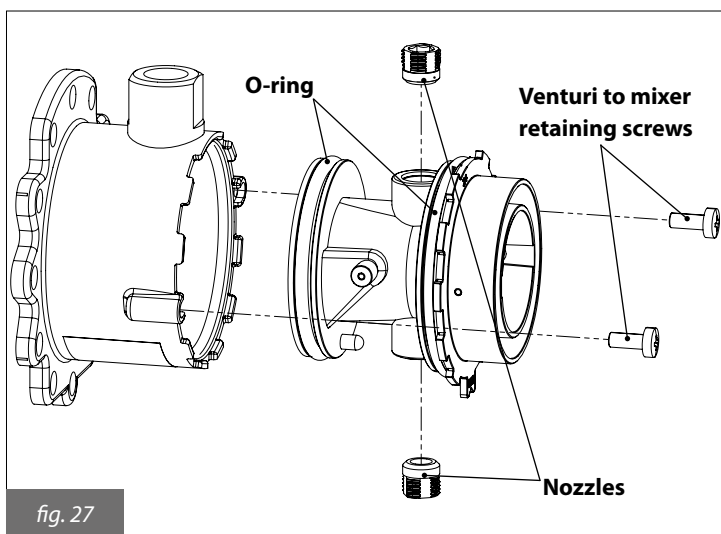
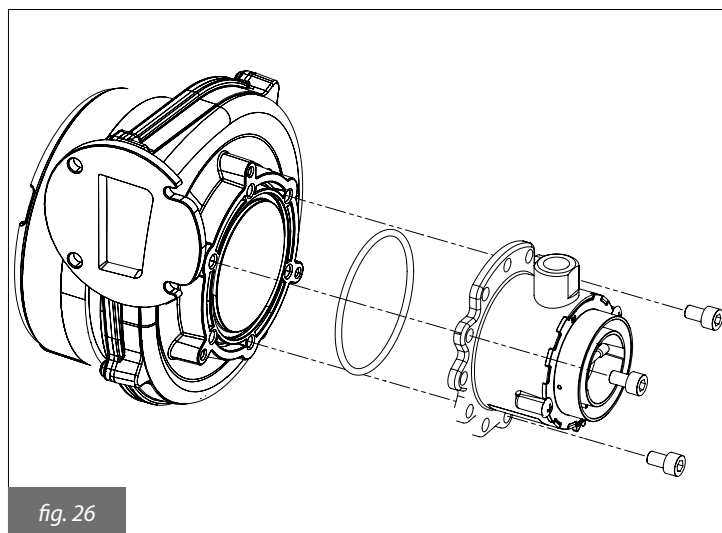
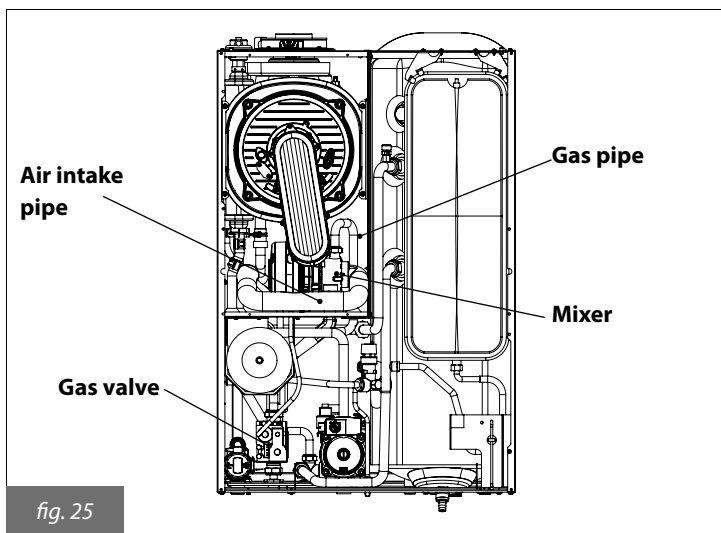

### 3.7.3. Gas valve setting

#### 3.7.3.1. Maximum heating output adjustment

- Make sure that the ambient thermostat (optional), if fitted, is set to ON.
- Select the "heating" mode on the control panel pressing key n times until symbol is displayed.
- Start the 'flue cleaning' function by keeping key pressed until symbol stops flashing. Boiler switches to max. output operation.
- If a gas switching has been made, access the programming page and set the P0-P4-P5-P6-P7-P8 parameters based on the power and on the gas, as specified in tab. 10.
- Set the flue (CO<sub>2</sub>) rate by turning the ratio adjuster **B** (pic. 29) and ensure that reading falls within the limits of tab. 13. Let boiler flue cleaning function on and continue with the next point "Minimum heating output adjustment".

#### 3.7.3.2. Minimum heating output adjustment

- Set boiler min. output operation by keeping symbol '-' pressed on the heating temperature adjustment key until the value corresponding to fan min. speed for the output and boiler gas (refer to tab. 10) is displayed.
- Boiler switches to min. output operation.
- Set the flue (CO<sub>2</sub>) rate by turning the offset adjuster **C** (pic. 29) and ensure that reading falls within the limits of tab. 13.
- Keep key pressed to end the flue cleaning function.

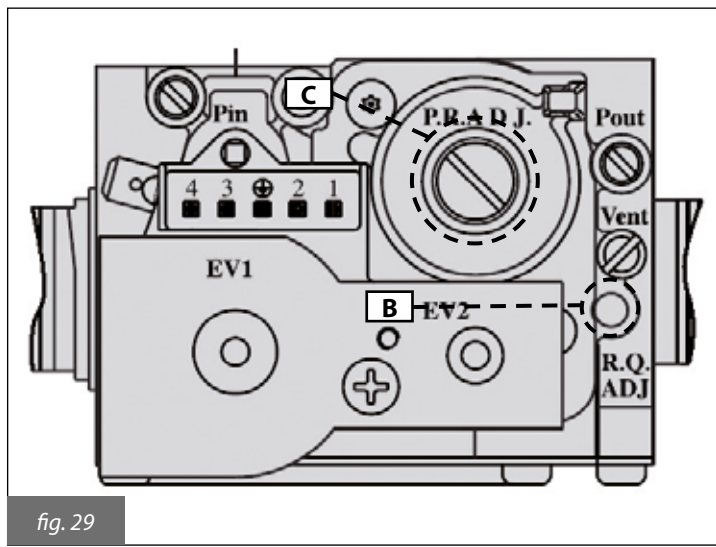

fig. 29

FLUE CO <sub>2</sub> RATE	
Fuel	CO <sub>2</sub> rate (%)
24 kW Methane gas	9.0 - 9.3
24 kW Propane gas	10.0
32 kW Methane gas	9.0 - 9.3
32 kW Propane gas	10.0

Table 13 - CO<sub>2</sub> rates

DIAMETER OF NOZZLES / DIAPHRAGMS (mm)		
	Methane gas	Propane gas
24 kW	3.70	3.00
32 kW	4.45	3.55 + diaphragm Ø 7.2

Table 14 - Diameter of nozzles - diaphragms

## 4. TESTING THE BOILER

### 4.1. Preliminary checks

Before testing the boiler, it is recommended to check the following:

- the flue gas venting duct and the relative terminal are installed in conformity with the instructions: **with the boiler operating there must be no leakage of combustion by-products from any of the gaskets;**
- the boiler is powered by a 230 V - 50 Hz mains supply;
- the system is correctly filled with water (pressure gauge reading 1 to 1.3 bar);
- any shut-off cocks in the system pipes are open;
- the mains gas type is correct for the boiler calibration: convert the boiler to the available gas when necessary (see section no. 3.7.); this operation must only be performed by qualified technical personnel;
- the gas supply cock is open;
- **there are no fuel gas leaks;**
- the main switch installed ahead of the boiler is turned on;
- the 3-bar safety valve is not stuck;
- there are no water leaks;
- the pump has not seized;
- the condensate trap installed on the boiler is discharging condensate correctly and is not stuck.



**Should the boiler not be installed in compliance with the prevailing laws and standards, notify the system supervisor and do not test the boiler.**

### 4.2. Switching on and switching off

To switch the boiler on and off, refer to the "**Instructions for the User**".

## 5. MAINTENANCE

**Any maintenance (and repair) work must only be carried out by qualified personnel.**

The user is strongly advised to have the boiler serviced and repaired by a qualified Service Centre.

Appropriate boiler maintenance ensures efficient operation, environment preservation, and safety for people, animals and objects.



**Once maintenance operations are finished, refit front panel, power off and on again using the switch installed ahead of the boiler.**

### 5.1. Maintenance schedule

The boiler must be serviced at least once every year.



**Disconnect electric power supply before starting any maintenance procedure, involving replacement of components and/or cleaning inside parts of boiler.**

Maintenance operations include check and cleaning procedures. In particular:

#### Inspections and checks:

- check general integrity of the boiler;
- check boiler and network gas supply for leakage;
- check gas supply pressure to boiler;
- check boiler ignition sequence;
- check boiler combustion parameters by flue gas analysis;
- check the condition and seal integrity of the flue gas venting pipes;
- check the state of combustion fan;
- check integrity of safety devices of the boiler in general;
- check for water leaks and oxidised areas on the boiler's couplings;
- check efficiency of the system safety valves;
- check expansion vessel filling pressure;
- check correct draining of condensate from the condensate trap installed on the boiler;
- check wear and tear and, if necessary, replace water heater magnesium anode.

#### The following cleaning is to be done:

- clean the general interior of the boiler;
- clean the gas nozzle;
- clean the air intake and flue gas venting circuits;
- clean the heat exchanger;
- clean the condensate trap and discharge ducts.

When checking the boiler for the very first time, also verify:

- boiler room suitability;
- diameter and length of flue gas system ducts;
- boiler installation in accordance to this "Installation use and maintenance" manual instructions.

**Should the boiler not operate correctly, while not posing danger to people, animals or property, notify the system supervisor both verbally and in writing.**

### 5.2. Combustion analysis

The combustion parameters of the boiler, which have to be checked in order to determine efficiency and emissions, must be measured in compliance with applicable legislation and standards.

## 6. TROUBLESHOOTING

BOILER STATUS	MALFUNCTION	PROBABLE CAUSE	SOLUTION
E01*	Burner does not ignite	Gas supply failure.	Check gas supply. Check gas supply cock or gas network safety valve intervention.
		Gas valve is disconnected.	Reconnect it.
		Gas valve is faulty.	Replace it.
		The board is faulty.	Replace it.
	Burner does not ignite: there is no spark	Ignition relay is faulty.	Replace the electrode.
		Ignition transformer is faulty	Replace the ignition transformer.
		Electronic board does not ignite. It is faulty.	Replace electronic board.
	Burner ignites for a few seconds and goes off.	Electronic board does not detect flame: inverted phase and neutral.	Check the correct phase-neutral connection to the power supply.
		Detection electrode cable is interrupted.	Reconnect or replace wire.
		Detection electrode is faulty.	Replace the electrode.
		Electronic board does not detect flame: it is faulty.	Replace electronic board.
		Ignition heat input setting is too low.	Increase it
		Minimum heat input is not set correctly.	Check burner setting
E02*	Flow temperature exceeded the max. allowed value.	Circulation pump is faulty.	Replace it.
		Circulation pump is seized.	Check pump electrical connection.
E03*	Flue thermostat triggering.	Poor flue draught.	Check the chimney and ambient air suction openings.
		Flue gas / air intake duct is obstructed.	Check for any duct obstruction, and eliminate.
		Flue gas thermostat is faulty.	Replace it.
E04**	CH system water pressure is low.	The system is leaking.	Check system.
		Pressure transducer is disconnected.	Reconnect it.
		Pressure transducer is faulty.	Replace it.
E05**	CH flow probe failure	Flow probe is electrically disconnected.	Reconnect it.
		Flow probe faulty.	Replace it.
E07**	Flue gas probe failure	Flue probe is electrically disconnected.	Reconnect it.
		Flue probe is faulty.	Replace it.
E09	System pressure is too close to the max. limit.	During manual filling, a system pressure too close to the safety valve drain value has been restored.	Progressively drain the system until the error symbol disappears.
E12**	Water heater probe failure	Probe is disconnected.	Reconnect it.
		Probe is faulty.	Replace it.
E15**	Return probe failure	Probe is disconnected.	Reconnect it.
		Probe is faulty.	Replace it.
E31**	Remote Control connection failure (only shown on Remote Control display).	The Remote Control is not connected to boiler board.	Reconnect it.
		Remote control faulty.	Replace it.
		Boiler board is faulty.	Replace it.



BOILER STATUS	MALFUNCTION	PROBABLE CAUSE	SOLUTION
<b>E35**</b>	Safety thermostat protecting the mixed 'zone 2' triggering (with zone kit installed, only)	Mixer valve is faulty.	Replace it.
		Thermostat is disconnected.	Reconnect it.
		Thermostat is faulty	Replace it.
<b>E36**</b>	Flow probe failure on one of the installed zones.	Probe is disconnected.	Reconnect it.
		Probe is faulty.	Replace it.
<b>E40*</b>	Fan failure.	Fan disconnected.	Reconnect it.
		Fan faulty.	Replace it.
<b>E41**</b>	No communication between board and peripheral devices (panel interface and/or zone/solar boards).	Interface display is disconnected.	Reconnect it.
		Zone/solar boards are disconnected.	Reconnect them.
		Interface display and/or zone/solar boards are faulty.	Replace them.
<b>E42</b>	Solar heating plant setting error.	Wrong boiler board or solar board setting parameters.	Check that the P03 and P18 parameter set values match with those specified on the reference tables.
<b>E44**</b>	Ambient probe 1 failure.	Ambient probe is disconnected	Reconnect it.
		Ambient probe is faulty	Replace it.
<b>E45**</b>	Ambient probe 2 failure.	Ambient probe is disconnected	Reconnect it.
		Ambient probe is faulty	Replace it.
<b>E46</b>	Pressure transducer failure.	Pressure transducer is disconnected.	Reconnect it.
		Pressure transducer is faulty.	Replace it.
<b>E49</b>	The interface does not work.	The interface does not communicate with the boiler board.	Replace it.
<b>E80*</b>	The $\Delta T$ between flow and return is not within the limits.	Flow and/or return probes are faulty.	Replace them.
		Obstructed bypass pipe	Remove any obstructions, or replace the pipe.
		The bypass valve is not assembled or wrongly assembled.	Restore bypass valve correct assembling.
		Heat exchanger primary circuit is obstructed.	Clean or replace the exchanger
<b>E86*</b>	Flow temperature increases too quickly.	Pump is seized.	Unseize the pump.
		Pump is faulty.	Replace it.
		Air present inside heating system.	Bleed the air from the boiler by opening the jollies on the exchanger and pump.
<b>E87*</b>	Flow temperature increases too quickly.	Circulation of foreign water in boiler.	Check that there are no other boilers or additional cascading heat sources.
		Air present inside heating system.	Bleed the air from the boiler by opening the jollies on the exchanger and pump.
<b>E89***</b>	Faulty flue temperature value.	Flue probe on heat exchanger is faulty or damaged.	Replace it.
<b>E98</b>	The max. number of resets from the boiler touch screen has been reached.	The user has reached the max. number of resettable errors from boiler control panel.	Power off and then on using the switch installed ahead of the boiler.
<b>E99</b>	The max. number of resets from the Remote Control has been reached.	The user has reached the max. number of resettable values from the Remote Control.	Reset boiler interface.

- \* errors that can be reset by the user by keeping the 'Reset' button pressed
- \*\* self-resettable errors, they automatically reset as soon as the failure is corrected
- \*\*\* errors that can be reset only by the Technical Service personnel

In case errors **E51, E52, E53, E73, E85, E90 and E91** might occur, contact a qualified Service Centre.

# MANUFACTURER'S COMPLIANCE STATEMENT

Gas Directive 2009/142/EC  
Efficiency Requirements Directive 92/42/EC  
Electromagnetic Compatibility Directive 2004/108/EC  
Low Voltage Directive 2006/95/EC

**FONDITAL S.p.A.**  
having its registered office in  
**Via Cerreto 40 - 25079 Vobarno (BS), Italy**

## STATES

that the products

**Itaca KB 24, Itaca KB 32**

are manufactured in conformity

1. With the Type described in the CE-Type Examination Certificate  
and in the CE-Type Examination Certificate

**51CM4094**  
**51CM4095DR**

following the provisions of the Directives  
**Gas Directive 2009/142/EC**  
**Efficiency Requirements Directive 92/42/EC**  
which satisfy the essential requisites.

2. With the provisions of the **Electromagnetic Compatibility Directive 2004/108/EC.**
3. With the provisions of the **Low Voltage Directive 2006/95/EC.**

**Fondital S.p.A.**

For management  
Officer i/c Technical Office

Eng. Roberto Cavallini

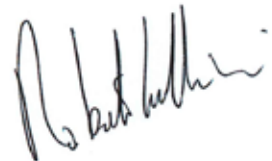

Vobarno, date of issue or of postal mark





0LIBMCEN30

**Fondital S.p.A.**

25079 VOBARNO (Brescia) Italy - Via Cerreto, 40  
Tel. +39 0365/878.31 - Fax +39 0365/878.304  
e mail: [info@fondital.it](mailto:info@fondital.it) - [www.fondital.com](http://www.fondital.com)

The manufacturer reserves the right to modify his/her products as deemed necessary, without altering the basic characteristics of the products themselves.