



LIPARI TN

11i - 14i

IST 03 C 1079 - 01

DOMESTIC GAS WATER HEATERS INSTALLATION, USE AND MAINTENANCE

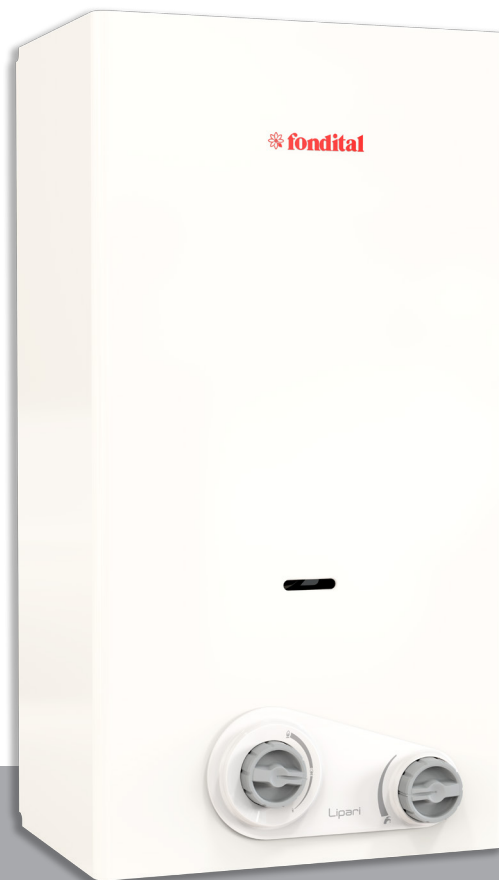

CE

EN

Translation of the original
instructions (in Italian)

 **fondital**

The device is well built in accordance with the current legislation.

The CE sign positioned on the product indicates that it conforms to the following European Directives:

- **Gas appliance directive 2009/142/EC**
- **Directive 2009/125/EC Ecodesign requirements for energy-related products**
- **Directive 2010/30/EU Indication of the consumption of energy by labelling**
- **Delegated regulation (EU) no. 812/2013**
- **Delegated regulation (EU) no. 814/2013**



The appliance complies with the European Directive 2010/30/EU “ErP Energy Labelling”.

The energy label carries the information regarding the product's energy efficiency characteristics.

In this way the end consumer can identify and compare similar products and can make informed choices regarding high efficiency appliances.

Below is a description of the label fixed to the shell of the appliance and the product sheet with the information required by the Directive.

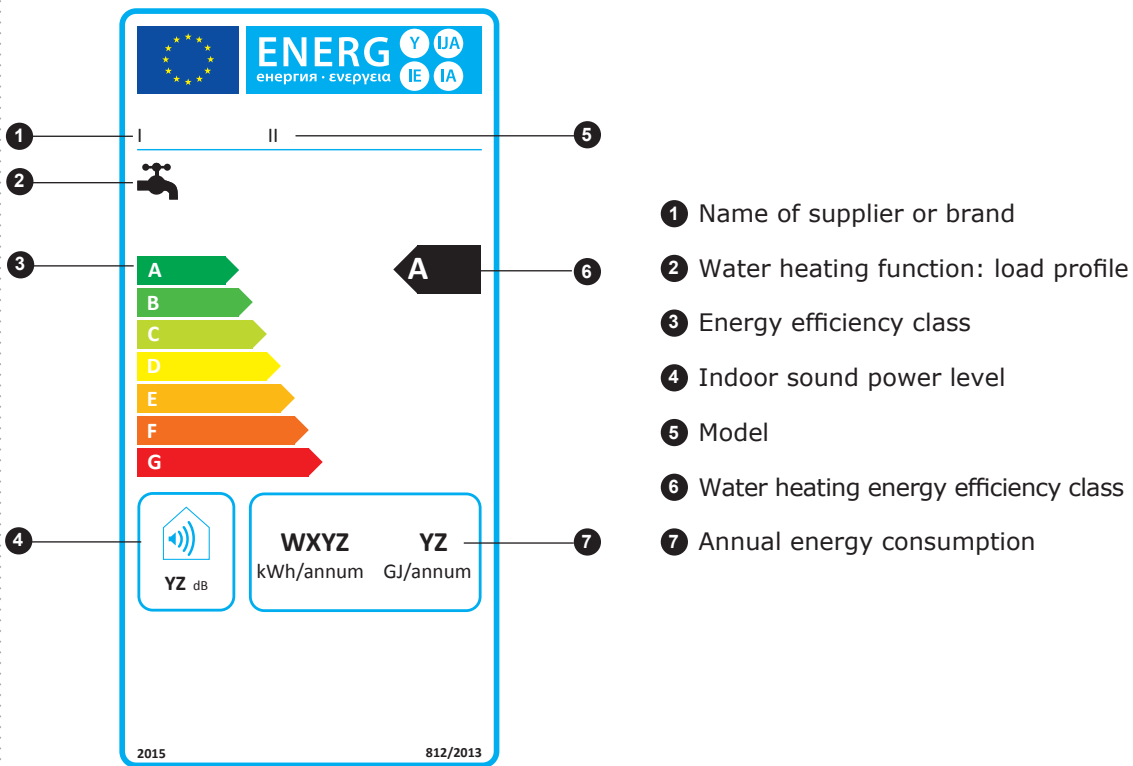

PRODUCT DATASHEET			
Fondital		Lipari Tn 11i	Lipari Tn 14i
2	Declared load profile	M	L
4	Indoor sound power level	dB(A)	56
6	Water heating energy efficiency class	A	A
	Water heating energy efficiency class	%	73,8
7	Annual energy consumption	GJ	6
	Annual energy consumption	kWh	0
	Nitrogen oxide emissions	mg/kWh	103



WARNING



This booklet contains information relevant to the user as well as the installer.
The user must read the following chapters: General safety, Flue gas device and Operation.

INDEX

GENERAL SAFETY	pag. 5
1 TECHNICAL CHARACTERISTICS	pag. 5
1. a Dimensions	pag. 5
1. b Main components	pag. 6
1. c Technical Data	pag. 7
2 INSTALLATION	pag. 8
2. a Regulations	pag. 8
2. b Mounting to wall	pag. 8
2. c Room ventilation	pag. 8
2. d Electrical connection to battery	pag. 8
2. e Gas Connection	pag. 9
2. f Water connection	pag. 9
2. g Disposal of waste product	pag. 9
2. h Gas transformation	pag. 10
3 OPERATION	pag. 12
3. a Function	pag. 12
3. b Usage	pag. 12
4 MAINTENANCE	pag. 13
4. a Removing the casing	pag. 13
4. b Troubleshooting: Problems and solutions	pag. 14
5 GENERAL TERMS OF WARRANTY	pag. 15

In parts of the manual the following symbols are used:



WARNING = for actions that require caution and adequate preparation



PROHIBITED = for actions that MUST NOT be performed

The water heater package contains:

- 2 Two knobs to attach to the control panel after installation
- 1 Water filter to insert in the water valve pipe fitting.

GENERAL SAFETY WARNINGS

The Operation Manual is an integral part of the product and so must be carefully preserved in order to accompany the product; if it is lost or damaged another copy can be requested from the Technical Assistance Centre.

- ⚠ The installation of the device and any other repairs or maintenance must be performed by qualified personnel according to the law in force, in compliance with the installing regulations including any revisions.
- ⚠ It is recommended that trained personnel install the device.
- ⚠ The device must be used according to the manufacturer specifications. The manufacturer cannot be held contractually or otherwise responsible for damage caused to persons, animals or objects as a result of incorrect installation, repair or maintenance or improper usage.
- ⚠ The product's safety or automatic regulation devices must not be modified unless performed by the manufacturer.
- ⚠ This device is intended for heating water and therefore must be connected to a water distribution network who's load and settings are compatible with the product.
- ⚠ If water spills, turn off the water supply and advise the qualified personnel at the Technical Assistance Centre.
- ⚠ If the machine is not used for prolonged periods turn off the gas supply. If there is a risk of the water freezing, empty the water heater.
- ⚠ If the machine breaks down or does not function properly, deactivate it, do not attempt to perform any repairs.
- ⚠ The machine's maintenance must be performed at least once a year: Book a maintenance session with the Technical Assistance Centre ahead of time to save wasting time and money afterwards.
- ⚠ When the product has reached the end of its serviceable life, it shall be disposed of in an environmentally friendly way; ensuring that the majority of the product is fully recycled.

When using the device the following safety rules must be applied:

- ⊘ Do not use the machine for purposes other than those intended by the manufacturer.
- ⊘ Do not block the intake and dissipation grills or the ventilation openings in the area where the device is installed with rags, paper or any other materials.
- ⊘ If a gas leak is detected, do not switch on any electrical devices, telephones or any other objects that could produce a spark. Ventilate the area by opening the doors and windows and switch off the gas supply.
- ⊘ Do not place objects on top of the device.
- ⊘ Do not leave flammable containers or substances in the area where the device is installed.
- ⊘ Do not attempt to repair the machine if it breaks down and/or works incorrectly.
- ⊘ Children or inexperienced persons are prohibited from using the device.
- ⊘ It is prohibited to open sealed elements.

To maintain the proper functioning of the device:

- Periodically clean the devices exterior with soapy water, this improves its appearance as well as preserving it from corrosion in the long term.
- Do not use solvents, powders or abrasive sponges.
- Do not clean the device and/or its parts with flammable materials (e.g. petrol, alcohol, diesel etc.).

1. TECHNICAL CHARACTERISTICS

1.a Dimensions

Misure in mm

	Tn 11i	Tn 14i
A	592	650
B (Ø)	110	130
C	101	101
D	245	245
E	314	365
F	97	117
G	31	51
H	83	103
I	70	94

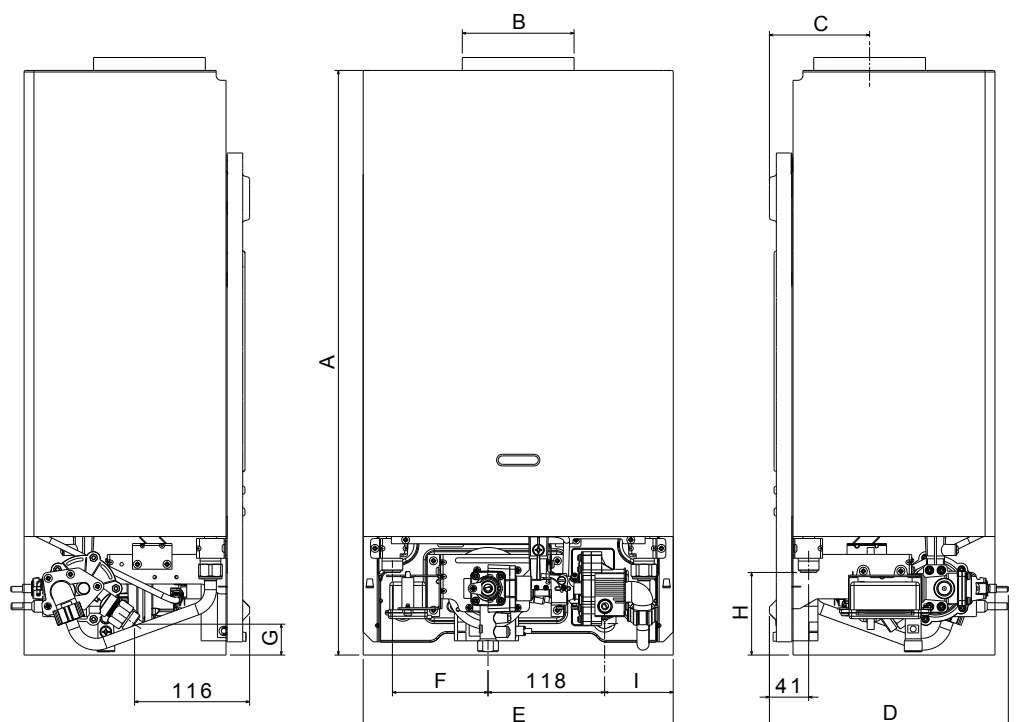
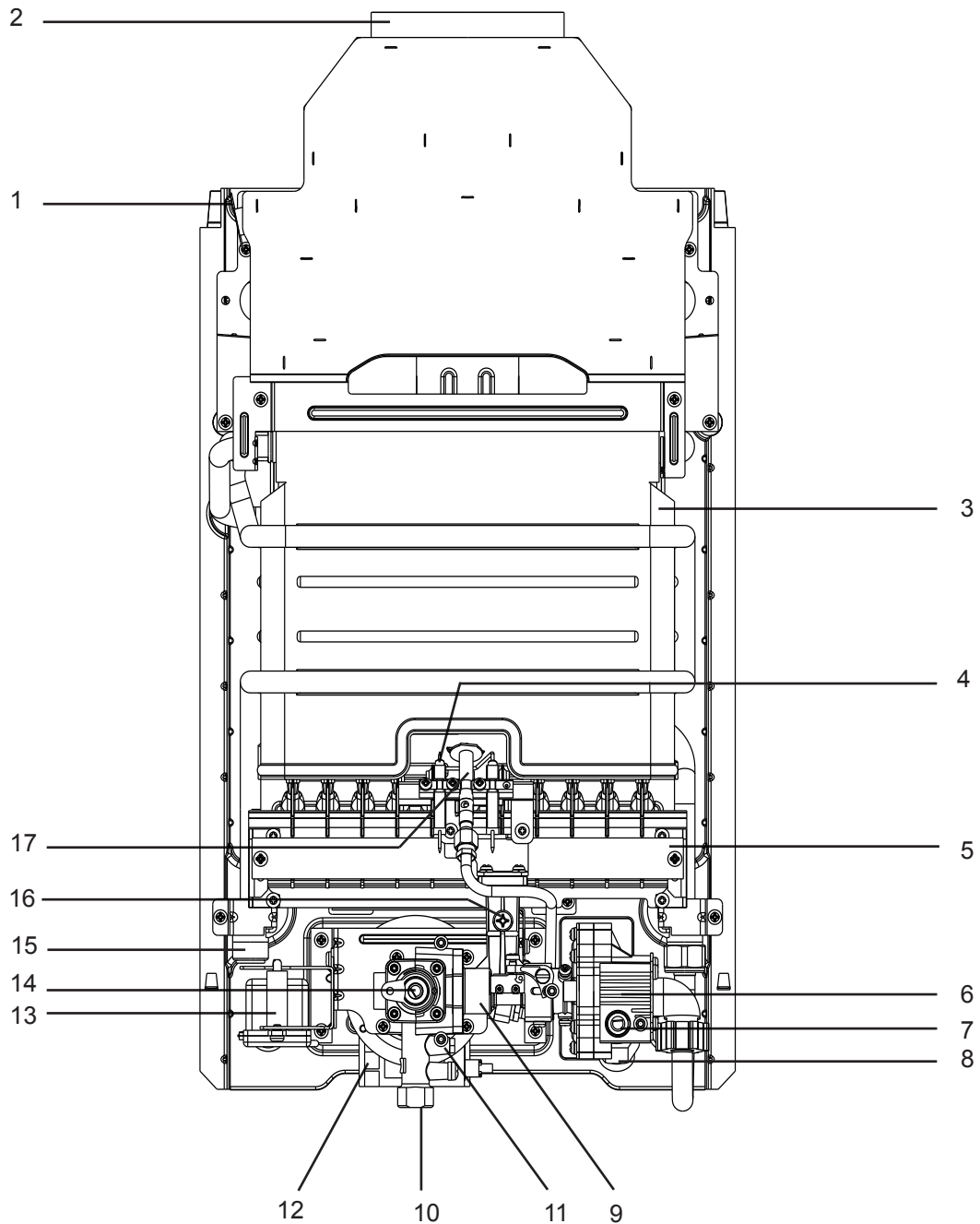

Fig. 1

1.b Main components



1	Flue gas release safety device
2	Release hood
3	Heat exchanger
4	Ignition electrode
5	Burner
6	Hydraulic valve
7	Temperature regulator
8	Water input
9	Gas valve
10	Gas input
11	Gas adjustment screws
12	Electronic devices
13	Battery box
14	Economiser
15	Water outlet
16	Gas pressure intake
17	Pilot burner

Fig. 2

1.c Technical Data

Lipari		Tn 11i			Tn 14i			
		kW - kcal/h			kW - kcal/h			
Nominal power usage (Pn)		19,0 - 16.340			23,7 - 20.374			
Nominal Thermal range (Qn)		21,8 - 18.748			27,2 - 23.392			
Minimal power usage (Pm)		7,5 - 6.424			7,5 - 6.424			
Minimal Thermal range (Qm)		9,0 - 7.740			9,0 - 7.740			
GAS TYPE		METHANE GAS	BUTANE	PROPANE	METHANE GAS	BUTANE	PROPANE	
		G20	G30	G31	G20	G30	G31	
P.C.I. (15° C 1013 mbar)	MJ/m ³	34,02	116,09	88	34,02	116,09	88	
W.I. (15° C 1013 mbar)	MJ/m ³	45,67	80,58	70,69	45,67	80,58	70,69	
Nominal feed pressure		mbar	20	28-30	37	20	28-30	37
Consumption	m ³ /h	2,31	-	-	2,88	-	-	
	kg/h	-	1,72	1,69	-	2,14	2,11	
Burner Pressure		mbar	12,20	27,50	35,10	13,00	27,00	34,30
Ø pilot flame nozzle		mm	0,35	0,25		0,35	0,25	
Ø main burner nozzle		mm	1,18	0,71		1,18	0,72	
nozzles		N.	11			13		
Ø gas connection			1/2"			1/2"		
Maximum flue gas load		g/s	13,20	12,40	13,00	18,40	17,70	19,00
flue gas temperature		°C	185	180	182	168	163	158
Category			II2H3+			II2H3+		

WATER		Tn 11i		Tn 14i	
Input range	l/min	select. min. from 2,5 to 5	select. max from 5 to 10,8	select. min. from 2,5 to 6,7	select. max from 6,7 to 13,6
Water temperature elevation	°C	approximately 50	approximately 25	approximately 50	approximately 25
Minimum pressure		0,2		0,2	
Nominal pressure		2		2	
Maximum pressure		10		10	
Ø Water connections		1/2"		1/2"	
Ø flue gas release tube		110		130	

DIMENSIONS AND WEIGHTS		DEVICE	PACKAGE	DEVICE	PACKAGE
Height	mm	592	655	650	713
Length	mm	314	361	363	410
Depth	mm	245	280	245	280
Weight	Kg	11,10	12,30	12,60	14,00

Nota: temperatura acqua fredda di riferimento di 15°C.

2. INSTALLATION

2.a Regulations

The use of gas devices is controlled by precise regulations. It is essential to observe regulations in force.

Installation of liquid petroleum gas (L.P.G) must comply with all the distributor's requirements and those of the regulations.

2.b Wall mounting

Warning

Do not install this device in an area that contains dust, greasy vapour and/or corrosive elements.

- The device must be installed on a suitable wall surface in proximity to a fume disposal flue
- It is vital to leave the minimal distances around the device as shown in Fig.3 to allow for maintenance operations to take place.

Location

The water heater must not be tightly placed in an enclosure or slot, it should have an adequate flow of air around it

- The water heater must not be placed above a kitchen or other cooking devices that might deposit grease vapour on its exterior leading to corrosion
- Surfaces that sensitive to heat (e.g. wood) must be protected using appropriate insulation.
- Fig. 4 displays the dimensions necessary for wall mounting

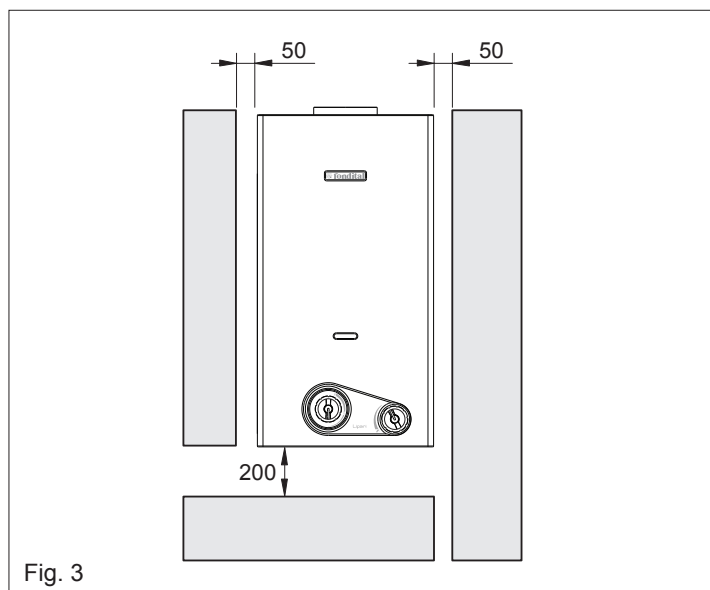

Fig. 3

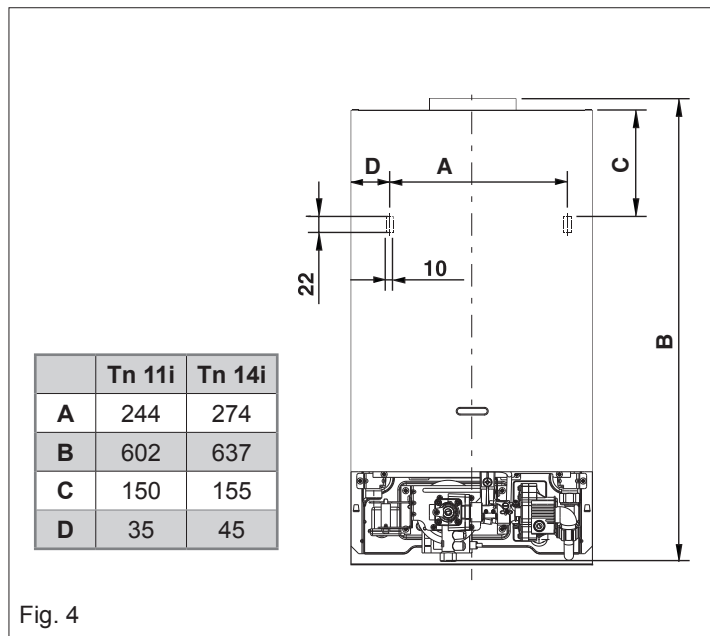

Fig. 4

2.c Room ventilation

The installation of the water heater must comply with regulations in force including any updates. See paragraph 2.a

Warning: This device can only be installed in venues that are permanently ventilated according to regulation in force.

Air circulation

It is vital that areas where gas devices are installed (type B) have access to the amount of air necessary for the regular combustion of gas as well as the ventilation of the venue.

- It is prohibited to use an extractor fan, fireplaces and other similar devices at the same time as the water heater
- The area where the water heater is installed must have a regular flow of air for ventilation.

Air flow

The flow of air must occur by the following means:

- Permanent openings in the wall that lead outdoors
- Single or collective ventilation ducts.

The air used for ventilation must be taken directly from an outside location, that is far from sources of pollution.

Indirect ventilation from adjacent areas are permitted with the following limitations:

- The adjacent area is equipped with direct ventilation
- The devices within the area to ventilate are connected to a waste duct
- The adjacent area does not contain a bedroom and is not a common area;
- The adjacent area is not a fire hazard such as a storage area for flammable materials, garage etc.
- The adjacent area is not lower than the area to ventilate as this might lead to an opposing draught (this can be caused by other devices that operate on the basis of combustion, a fireplace or any suction device that have not been given an adequate air supply)
- The air flow from the adjacent area occurs freely through permanent openings.

2.d Electrical connection to battery

The device is powered by a 1.5 V battery, alkaline long lasting model LR20, thus it is not necessary to connect the device to a power socket.

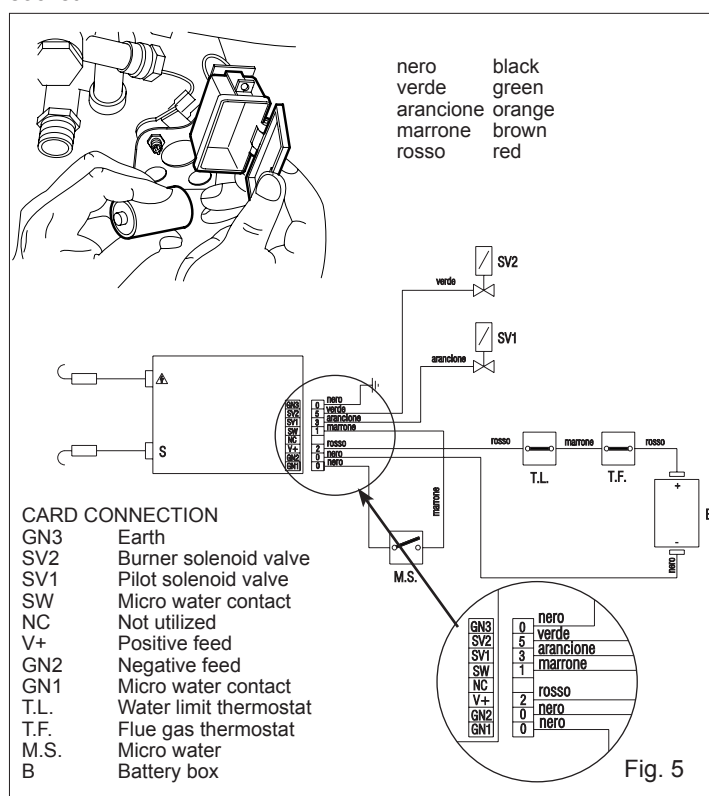

Fig. 5

2.e Gas Connection

See paragraph 2.a

Determine the pipe diameter according to current regulations. Before installing the device blow in the gas pipe to eliminate any residue from its manufacturing. Connect the water heater to the internal system's gas pipes and place a tap above the device for the halting and release of gas.

The water heaters that are powered by tanks of L.P.G. gas with regulation and interception devices, must be connected correctly so to guarantee the safety of persons and the surrounding area. Follow all related regulations.

When initially installing the device qualified persons must perform the following tests:

- Check that the internal and external parts of the gas supplying device are sealed;
- check that the gas quantity supplied is equal to that required by the device;
- check that the device receives the type of gas it is manufactured to process;
- check that the gas supply pressure does not go beyond the maximum pressure values displayed on the information plate;
- check that the gas supply system supplies the necessary amount of gas to the device and that it is equipped with all the necessary safety devices prescribed by current regulations.

If the user is absent for a lengthy period, turn off the main gas supply tap.

Do not obstruct the area's ventilation openings where the device is installed to avoid dangers such as the build up of toxic and explosive substances. Do not utilize gas tubes to earth electrical devices.

2.f Water connection

Connect the water heater to the water supply and insert a tap to intercept the water above the device. From the front, the cold water input is on the right and the hot water output is on the left.

- ⚠ Insert the filter into the water valve input fitting.
- ⚠ Remove the plastic nut from the hot water output fitting before connecting it to the water supply.

Ensure that the tubes of your water system are not used to earth your electrical system or telephone, they are absolutely inappropriate for performing this task.

In a short amount of time this can damage tubes and the device.

2.g Disposal of waste product

This B11BS water heater is supplied with a device for releasing flue gas.

For output of combustion by-products refer to the regulations in force including any updates. See paragraph 2.a

The gas devices with an attachment for a waste gas flue must be connected directly to properly working chimney or flue pipe; only if these devices are not present is it then permitted to release gases directly outside.

The fitting of devices to a chimney or flue pipe must occur via a smoke channel. Smoke channels must be connected to a chimney or a smoke channel in the same or adjacent area to where the device is installed and must be made of materials resistant to mechanical strain, heat and the effects of combustion by-products and their condensation. The flue gas temperature must always be above condensation temperature in all points of the smoke channel regardless of external conditions.

FLUE GAS RELEASE SAFETY DEVICE

The product is equipped with a series of flue gas release safety devices. The device ensures the correct release of combustion by-products; the flow of combustible gas to the release conduit and the smoke channel.

The safety device contains a "thermostat", it can stop the flow of gas to the main burner and the pilot flame.

The safety device can be triggered by the partial or total obstruction of the release conduit or the smoke channel.

To reset the device it is necessary to press the flue gas thermostat key (Fig. 7) close use a screwdriver and reopening the hot water tap.

If the device or its electrical connections breaks down, the product can not be put ON, it ensures a safe condition

If the device or its electrical connections breaks down, the machine operation is blocked.

If the machine is constantly blocked as a result of the flue gas safety device, it is necessa-

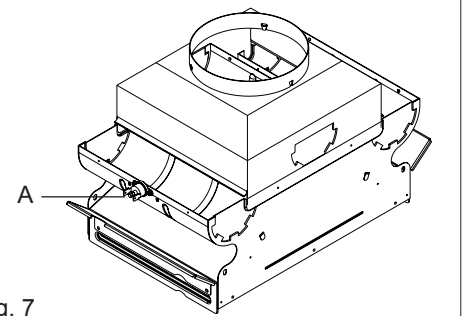

Fig. 7

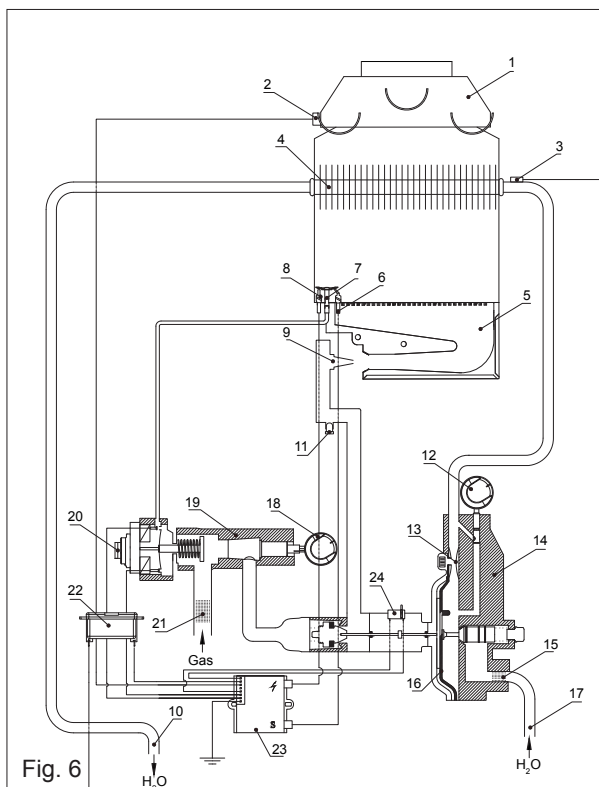

Fig. 6

1	Release hood
2	Flue gas safety device
3	Water limit thermostat
4	Heat exchanger
5	Burner
6	Sensor electrode
7	Pilot burner
8	Ignition electrode
9	Injector
10	Hot water output

11	Pressure intake
12	Temperature selector
13	Venturi
14	Hydraulic valve
15	Water filter
16	Membrane
17	Cold water input
18	Economiser
19	Gas valve
20	Safety device
21	Gas filter
22	Battery
23	Electrical card
24	Microswitch

ry to request the assistance of a qualified technician according to law in force, to check the correct release of flue gas through the release conduit and/or the smoke channel, according to the installation regulation.

It is highly prohibited to attempt to modify or remove the flue gas safety device; this risks the safety of the user and persons in the area. Only a qualified technician who is authorised by the manufacturer can meddle with the safety device in order to check its functionality or to substitute it if necessary.

If it is necessary to replace the device it is vital to only use "original parts" supplied by the manufacturer since it has been designed, studied and regulated to be fitted with the water heater.

2.h Gas transformation

Transforming the product so it may receive a different type of gas can be easily performed even while it is mounted. The instructions for transforming and regulating the product to receive various types of gas are below.

This operation must be performed by qualified personnel according to law in force.

TRANSFORMATION FROM METHANE TO LPG

Transforming the product so it may receive a different type of gas can be easily performed even while it is mounted.

Before any operation ensure that the gas and water supply are switched off.

I – SUBSTITUTION OF THE PILOT INJECTOR

- Disconnect the pilot flame tube (Fig. 8-9)
- Remove the pilot injector
- Insert the seal contained in the transformation kit (Fig. 10)

II – SUBSTITUTION OF THE BURNER INJECTORS

- Remove the screws that hold the pilot flame in position (Fig. 11)
- Remove the screws that hold the diffuser in place (Fig. 12)
- Turn on the left the pilot group (Fig. 13)
- Remove the 4 screws of the gas valve (Fig. 14)
- Disconnect the water valve from the water supply removing the inlet connection (Fig. 15)
- Disconnect the microswitch's cables (Fig. 16)
- Remove the connection (see part. 1 - Fig. 17) and turn on the right the water valve and the diffuser as indicated in Fig. 18
- Disconnect the water valve and the diffuser from the water inlet pipe by the nut (see part. 2 in Fig. 19 and 17) and at the same time extract the large spring and the small spring/modulation valve set (Fig. 20)
- Unscrew the injectors and substitute them with those found in the transformation kit (Fig. 21)

III – SUBSTITUTION OF THE MODULATION VALVE

After the operations of the points I and II

- Substitute the modulation valve with the one in the kit
- Insert the valve and the large spring, taking care with the direction of the insertion (Fig. 22-22a) and making sure that the drilled spring guide disc is in its correct position (Fig. 23)

IV – DISABLING THE GAS ADJUSTER

- Remove the protective cap (Fig. 24)
- Regulate the supply calibration screws so that the maximum amount of gas can pass (disk completely horizontal), referred to technical data tab.



It is necessary to use a pressure regulator that operates at 30 mbar for Butane Gas and at 37 mbar for Propane Gas. The above values must be measured using a barometer connected to the device's pressure entrance.

TRANSFORMATION FROM LPG TO METHANE GAS

Execute operations I, II and III described above

IV – ENABLING THE GAS ADJUSTER

- Remove the protective cap
- Regulate the pressure screws so that the burner reaches the pressure levels indicated on the technical data



Ensure that the gas pressure is at 20 mbar.

WARNING – IMPORTANT

After the gas transformation:



Check that all the disassembled parts are perfectly sealed once the device is operational using a soapy solution.



Write on adhesive paper "Converted to", including the date of the operation, the name and signature of the person who performed the transformation and attach it to the device near the older information plate.

IT	Trasformato a
EN	Converted to
FR	Transformé à
ES	Transformado en
PT	Transformado para
/ /	Sign.

IT-ES-PT: I2H3+
G20-20mbar
G30/G31-28-30/37mbar

N.G.
B11BS
I2H
G20: 20 mbar

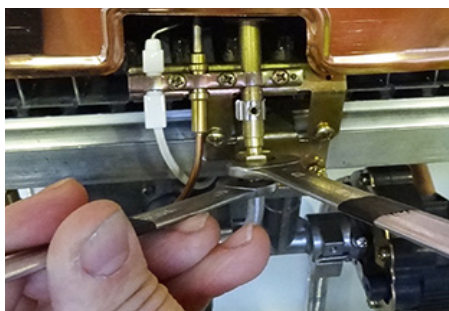

Fig. 8

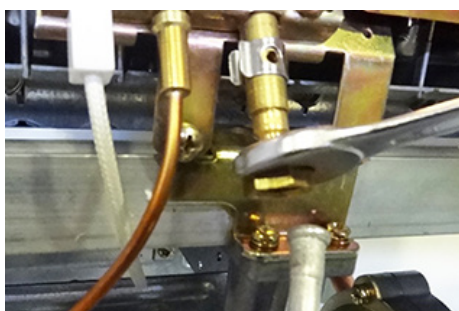

Fig. 9

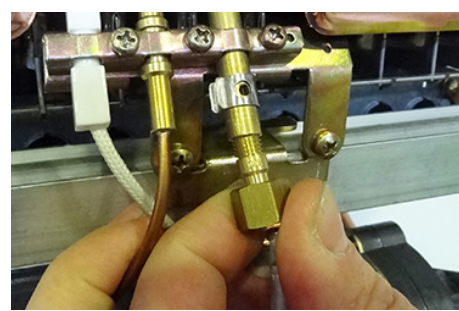

Fig. 10

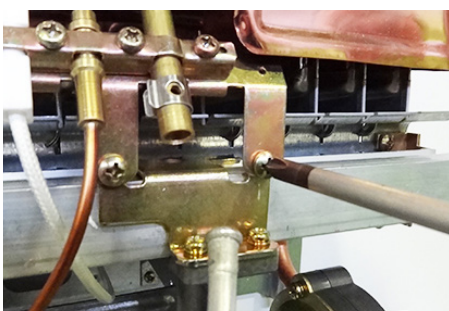

Fig. 11

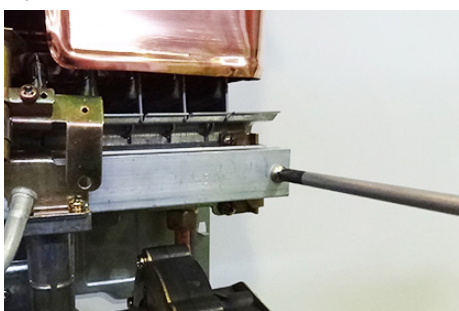

Fig. 12

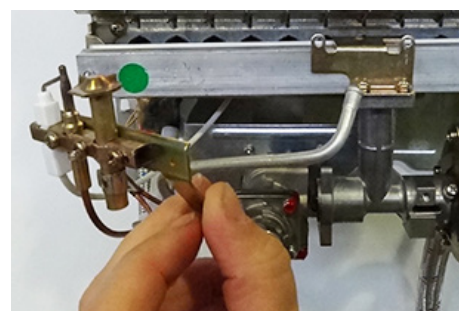

Fig. 13

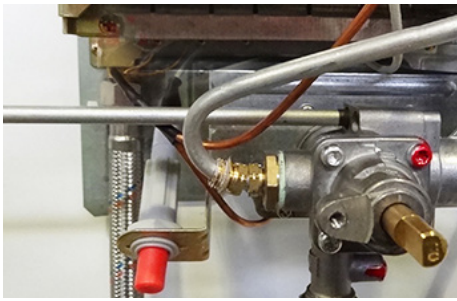

Fig. 14

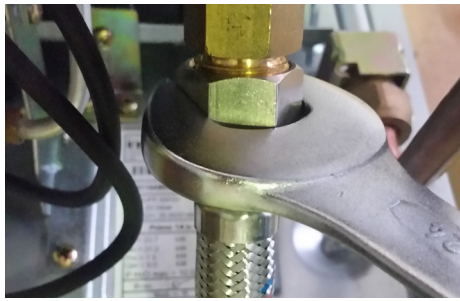

Fig. 15

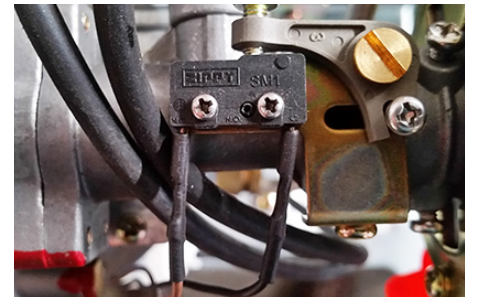

Fig. 16

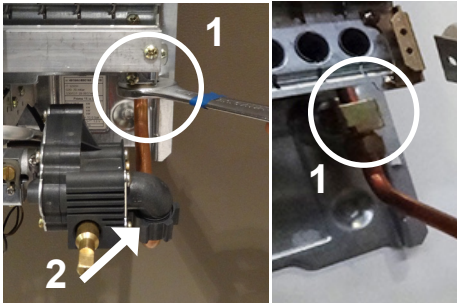

Fig. 17

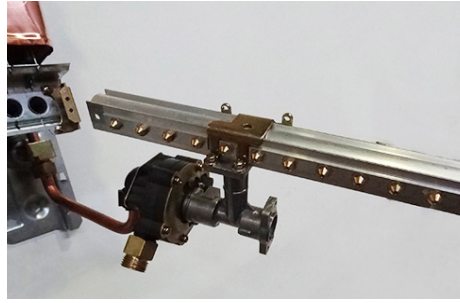

Fig. 18

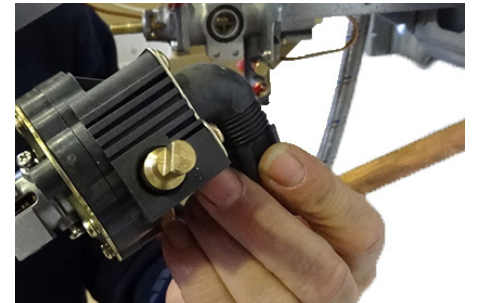

Fig. 19



Fig. 20

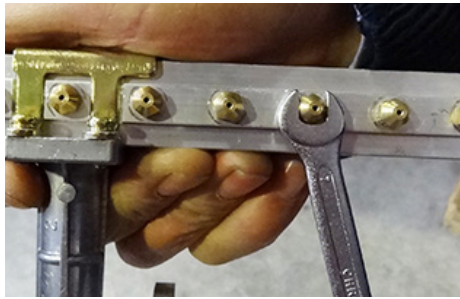

Fig. 21

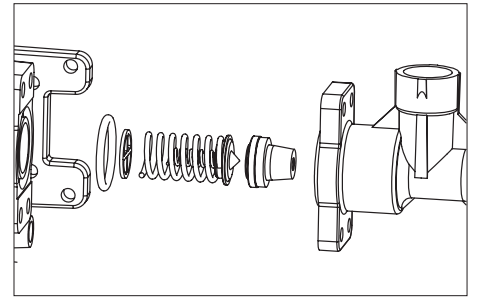

Fig. 22

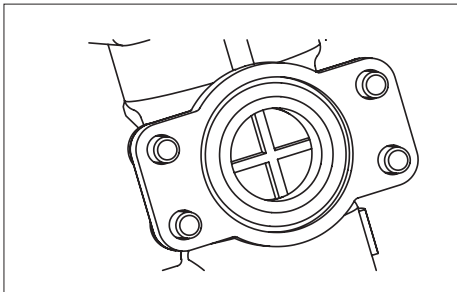

Fig. 23

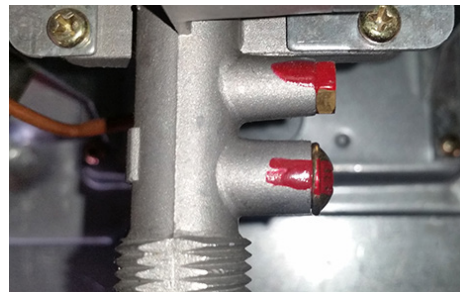
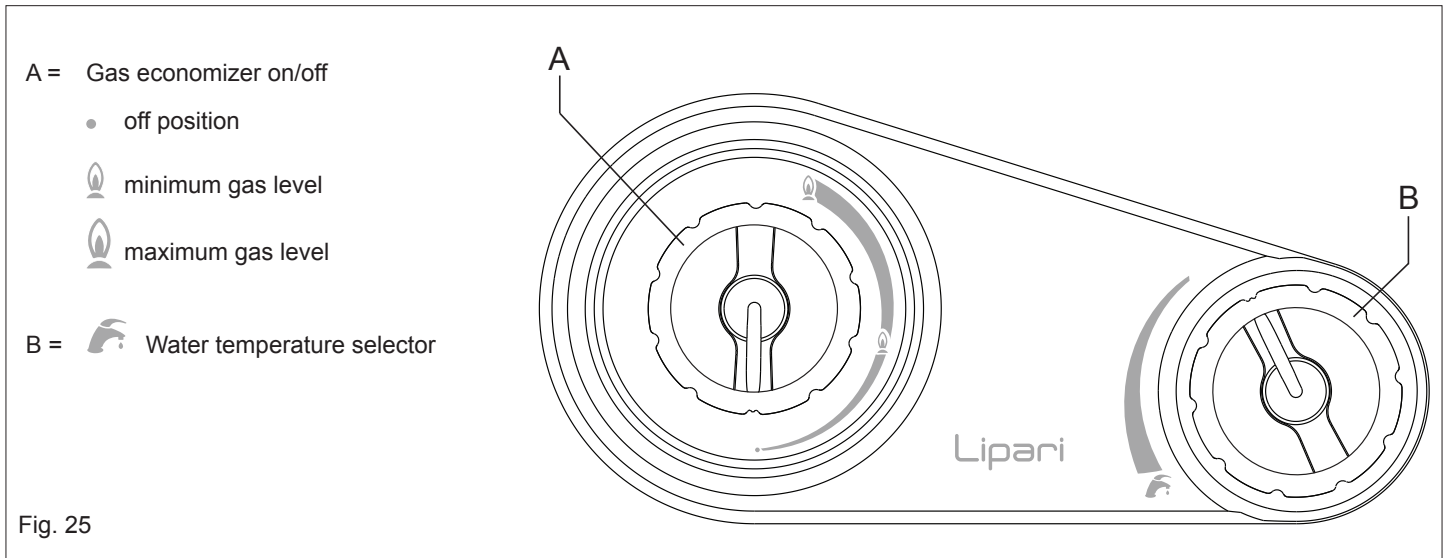

Fig. 24

3. OPERATION



3.a Function

The water heater is used for the production of instant hot water. The removal of hot water can be performed by multiple taps.

By turning on the relative tap, the main burner switches on heating the water that passes.

These devices with a modifiable flame are particularly suited for usage with mechanical mixers and thermostats.

This water heater, in contrast with other water heaters with a fixed flame, has a modulation valve to optimise the water heaters operation. It allows for the water to be heated using less water pressure and gas by modulating the flame according to the amount of water used, maintaining the water extracted at a constant temperature. The water heater uses automatic variation that is "PROPORTIONAL", able to change the gas consumption (modulating the flame) to respond to the amount of water extracted.

This device is equipped with an electronic tool that is powered by a 1.5 V battery that automatically switches on the pilot flame and then the burner every time that hot water is extracted.

The flame is switched on using a card that ionizes the flame

Lipari Tn 11i: for the extraction of 2,5 to 5 l/min the temperature of the water supplied remains at 60°C, (in this case the has valve supplies the burner with the necessary quantity of gas proportional to the water supplied), above 5 l/min to 11 l/min the water temperature varies from 60°C to 40°C.

Lipari Tn 14i: for the extraction of 2,5 to 7 l/min the temperature of the water supplied remains at 60°C, (in this case the has valve supplies the burner with the necessary quantity of gas proportional to the water supplied), above 7 l/min to 14 l/min the water temperature varies from 60°C to 40°C

3.b Usage

Ensure that the gas tap and all water taps are switched off

- Turn on the Main gas supply tap or that of the gas tank if using Liquefied Petroleum Gas (L.P.G.)
- Open the gas tap, not supplied with the device, placed immediately before the water heater on the gas input pipe
- Rotate knob A towards the large flame (ON 🔥), during rotation, when the small flame is reached it is necessary to press lightly while turning until it reaches its destination.
- When hot water is requested, the device automatically turns on the pilot flame, this lights the main burner.
- When the hot water request has terminated (turning the water tap off) the burner automatically switches off, the device then awaits another heating request.

If after 60 seconds it does not switch on, the flame detector interrupts the flow of gas and blocks the device.

To reuse the device after it has been blocked, close the hot water extraction tap and then reopen it to restart the sequence.

If the main burner accidentally switches off, the device will attempt to turn it on again.

If within 60 seconds the device does not function it is blocked.

The device is built to function with normal water pressure; in addition a temperature selector B is also supplied.

Rotate the knob completely to the left to obtain the maximum water output or completely to the right for the minimum water output.

The machine is switched off by rotating knob A to the (● OFF) position.

When the water heater is not used for long periods close the gas supply tap or the LPG gas valve on the tank.

For the best operational results it is recommended to have a qualified technician service the machine at least once a year.

Gas economizer

The device is equipped with a gas economizing device which is used to choose the temperature of the water so it may be supplied at the temperature necessary while saving gas.

The economizing device is activated by turning the knob A until it reaches the picture of the small flame (MIN 🔥). Using the economizer limits the amount of heating when the hot water usage is modest (water supplied is already warm or there is a reduced usage, for example in summer).

DANGER OF FREEZING

If there is a possibility that the area where the device is stalled could reach below 0°C, the device must be emptied of all water contained.

4. MAINTENANCE

To maintain the machine at maximum efficiency, have qualified personnel perform a maintenance check at least once a year.

Before cleaning or performing maintenance, opening or disassembling the panels, switch off the device and turn off the gas supply. Check the main burner and the pilot flame, the ignition electrode, the safety valve and that there is no leakage. Check that there is nothing obstructing the passages within the exchanger smoke channel.

To clean the outside of the panels utilize a cloth with soap and water.

Do not use solvents, powders or abrasive sponges.

Do not clean the device and/or its parts with flammable materials (e.g. petrol, alcohol, diesel etc.).

4.a Removing the casing

To remove the outer casing follow the steps below:

- Remove the selector Knobs (A and B)
- Remove the screws (C)
- Shift the casing upwards to free it from the upper and lateral hooks
- Shift the casing forwards
- To reinsert the casing, follow the above steps in reverse order

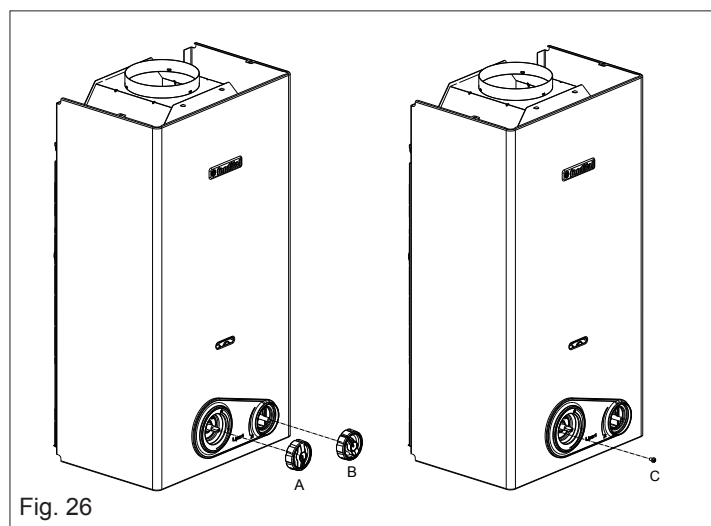

Fig. 26

4.b Troubleshooting: problems and solutions

For the best functioning of the water heater, to prolong its lifetime and ensure that it is always safe, ensure that it is inspected at least once a year by a trained professional. The trained professional is to perform the following maintenance operations:

- Remove any rust from the burner
- Remove any deposit on the glow plug by the electrode
- Clean the combustion tank
- Check the ignition, switching off and general functionality of the device
- Check that the gas and water tubes and connections are sealed

Warning: the following repair instructions are only to be performed by qualified and authorized technicians.

PROBLEM	CAUSE	SOLUTIONS
There is no spark	<ul style="list-style-type: none"> - Exhausted battery - Electrical cable of device is disconnected - Electrical card is broken - There isn't sufficient water pressure - The membrane is broken - The electrode is damaged 	<ul style="list-style-type: none"> - Substitute - Insert - Test, substitute - Repair the device to guarantee pressure, rotate the selector knob all the way to the right - Substitute - Substitute
The pilot does not switch on when there is a spark	<ul style="list-style-type: none"> - Safety device broken - No gas supply - Air in the gas tubes 	<ul style="list-style-type: none"> - Substitute - Open the gas tap - Release gas
The burner does not switch off when the water turns off	<ul style="list-style-type: none"> - Grime on the gas shutter - Valve piston or stem is locked in open position - Micro lever is locked in open position - If an LPG supply, check the gas pressure 	<ul style="list-style-type: none"> - Test, clean - Disassemble, clean and eventually substitute - Test - Regulate and if necessary substitute the tank pressure regulator
The exchanger blade becomes dirty in a small amount of time	<ul style="list-style-type: none"> - Poor draught or dusty surroundings - Yellow flame - Excess gas consumption 	<ul style="list-style-type: none"> - Check the smoke channel efficiency - Check the gas type and clean the burner - Check and regulate
There is a smell of gas	<ul style="list-style-type: none"> - Due to the loss of gas in the tubes, check the tubes and find the leak 	<ul style="list-style-type: none"> - Do not activate electric switches or any object that produces sparks in local area
There is a smell of gas	<ul style="list-style-type: none"> - It can be caused by obstruction in the flue gas circuit - Excess gas consumption 	<ul style="list-style-type: none"> - Check the efficiency of the smoke channel and the flue gas conduit - Check and regulate

5. GENERAL TERMS OF WARRANTY

The Warranty is the one provided by the regulations and laws governing the sale of consumer goods in the country of purchase. For further information contact the dealer/importer.

Warranty exclusions

The warranty is excluded with respect to damage, malfunctions and defects that may be detected on Fondital gas water heaters and caused by:

- a) Transport by third parties.
- b) Negligence in the storage and handling of the product.
- c) Inability to use the product and accessories, and failure to follow instructions and warnings outlined in the use and maintenance manual supplied.
- d) Insufficient flow rate and defective gas, water and power supplies.
- e) Tampering or work by personnel not authorised by the manufacturer.
- f) Installation of the product in an unsuitable place (internal or external) and problems arising from incorrect or improper installation.
- g) Inadequacy of flues and/or the flue gas venting pipe and combustion air intake, as well as use of components, flue pipes or heat transfer fluids that are not suitable for the type of products that are installed or are not Fondital original parts.
- h) Storage in unprotected areas of construction sites.
- i) Failure to empty the system or premature installation.
- j) Corrosion of the system and formation of limescale build-up or other deposits arising from the supply water.
- k) Failure to clean the system with suitable products whether it be new or old.
- l) Force majeure due to particular weather events (e.g., earthquakes, floods, lightning, storms, excessive precipitation, etc.), as well as fires, vandalism, theft; stray currents and/or harmful effects due to atmospheric elements.
- m) Use of inadequate fuel and/or in any case for reasons not depending on the manufacturer.
- n) Forced or prolonged suspension of product operation.

Furthermore, the warranty is considered void in the following cases:

- a) If the end user is not current with payments.
- b) If the system is not installed in full compliance with regulations and laws, as well as the instructions and warnings published in the installation, use and maintenance manual supplied with the product.
- c) In case of skipped or inadequate periodic maintenance.
- d) In case of use of non-original spare parts.

Furthermore, these operations are not covered by the warranty: plumbing, electrical, gas supply and flue connections, combustion analysis, as well as activities and operations to access the product, like disassembling furnishings or covers, preparation of scaffolding, use of platforms, cranes etc.

Moreover, the customer will bear all the expenses if service is required to rectify erroneous technical work, tampering, or, in any case, damage to the product not attributable to manufacturing defects.



O L I B M E E N S O

Fondital S.p.A.
25079 VOBARNO (Brescia) Italy - Via Cerreto, 40
Tel. +39 0365/878.31
Fax +39 0365/878.576
e-mail: info@fondital.it
www.fondital.com

The manufacturer reserves the right to modify his/her products as deemed necessary, without altering the basic characteristics of the products themselves.

Uff. Pubblicità Fondital IST 03 C 1079-01 Aprile 2017 (04/2017)