

Grant VortexBlue

Internal Combi

Condensing Oil Boiler Range

Installation and Servicing Instructions

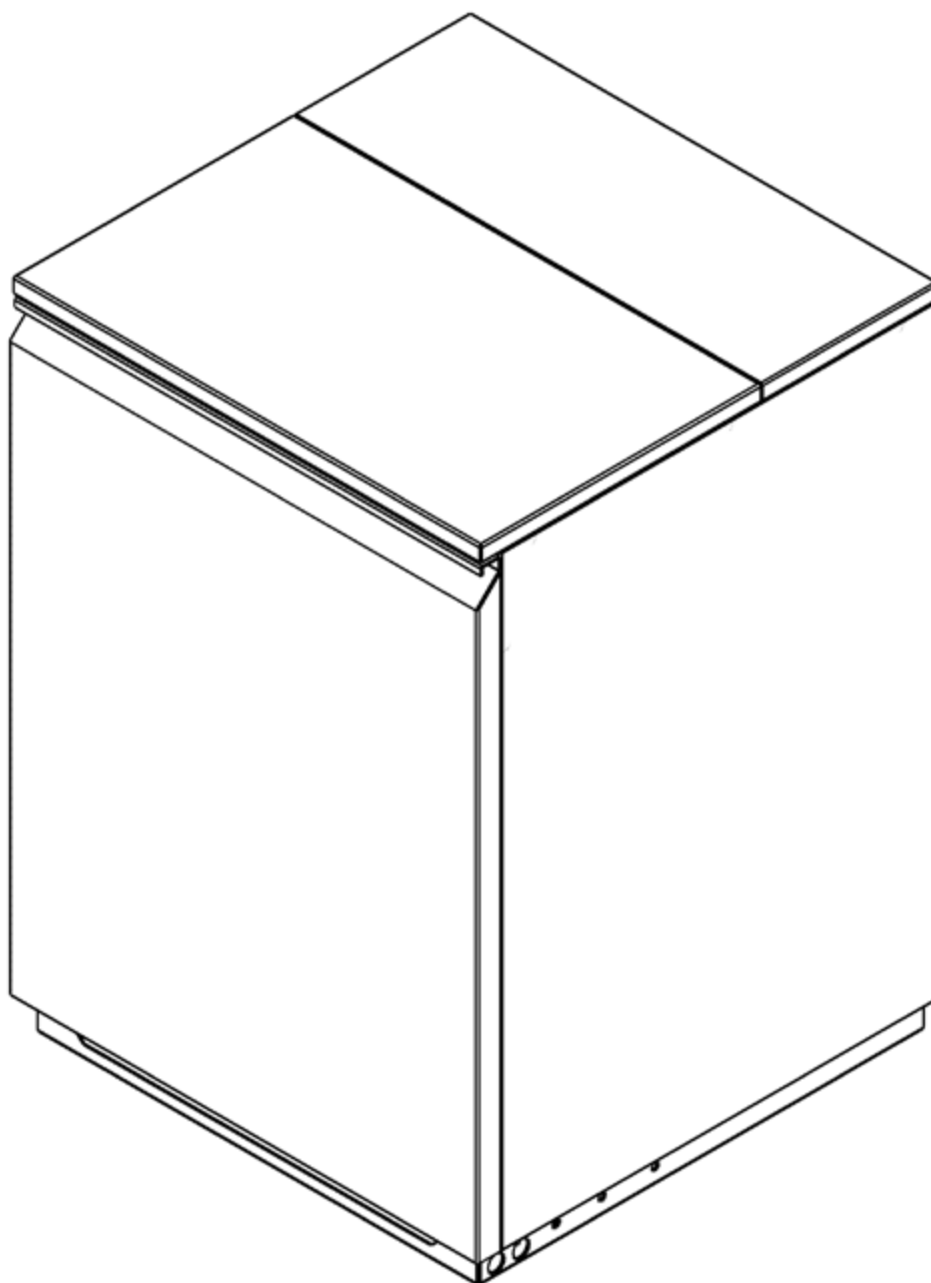
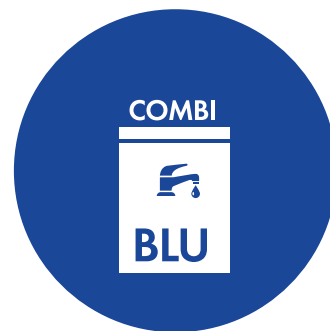

IMPORTANT NOTE FOR INSTALLERS

These instructions are intended to guide installers on the installation, commissioning and servicing of the Grant VortexBlue oil boiler. After installing the boiler, leave these instructions with the user.

A user handbook is available to guide users in the operation of the oil boiler.

SPECIAL TEXT FORMATS

The following special text formats are used in these instructions for the purposes listed below:

! WARNING !

Warning of possible human injury as a consequence of not following the instructions in the warning.

! CAUTION !

Caution concerning likely damage to equipment or tools as a consequence of not following the instructions in the caution.

! NOTE !

Used for emphasis or information not directly concerned with the surrounding text but of importance to the reader.

PRODUCT CODES AND SERIAL NUMBERS COVERED

The serial numbers used on Grant oil boilers consist of a fifteen digit numerical code with the final three digits being the product identifier.

For example:

100000200218727

These instructions cover the following product codes and serial numbers:

Product code	Serial number identifier
VTXBFCOMBI21	727
VTXBFCOMBI26	728
VTXBFCOMBI36	729

SERVICING

The boiler should be serviced at least every twelve months and the details entered in the Service Log in the user handbook.

FUEL TYPE

All Grant Vortex boilers are suitable for use with Class C2 Kerosene.

The use of Class D Gas Oil on all Grant Vortex Low NOx and Blue Flame boilers DOES NOT comply with ErP requirements or EU regulations, and as a result Grant UK does not condone its use.

Grant VortexBlue boilers are NOT suitable for use with bio-kerosene.

! NOTE !

This appliance can be used by children aged from 8 years and above and persons with reduced physical, sensory or mental capabilities or lack of experience and knowledge if they have been given supervision or instruction concerning use of the appliance in a safe way and understand the hazards involved.

Children shall not play with the appliance. Cleaning and user maintenance shall not be made by children without supervision.



GRANT ENGINEERING (UK) LIMITED

Hopton House, Hopton Industrial Estate, Devizes, Wiltshire, SN10 2EU

Tel: +44 (0)1380 736920 Fax: +44 (0)1380 736991

Email: info@grantuk.com www.grantuk.com

This manual is accurate at the date of printing but will be superseded and should be disregarded if specifications and/or appearances are changed in the interests of continued product improvement. However, no responsibility of any kind for any injury, death, loss, damage or delay however caused resulting from the use of this manual can be accepted by Grant Engineering (UK) Limited, the author or others involved in its publication.

All goods sold are subject to our official Conditions of Sale, a copy of which may be obtained on application.

© Grant Engineering (UK) Limited. No part of this manual may be reproduced by any means without prior written consent.

CONTENTS

1	INTRODUCTION	4	9	FLUE SYSTEM AND AIR SUPPLY	30
	1.1 How a condensing boiler operates	4		9.1 Air supply	30
	1.2 Boiler description	4		9.2 Conventional flue systems	30
	1.3 Flue options	4		9.3 Connecting a conventional flue	33
	1.4 Boiler components	5		9.4 Balanced flue systems	33
				9.5 Prepare the wall	37
				9.6 Flue clearances	38
2	TECHNICAL DATA	6	10	COMMISSIONING	40
	2.1 Boiler technical data	6		10.1 Before switching on	40
	2.2 Burner settings	7		10.2 Burner settings:	
	2.3 Flue gas analysis	7		RDB2.2 BG BLU Burners	41
	2.4 Boiler dimensions	8		Switching on	42
3	OIL STORAGE AND SUPPLY SYSTEM	10		10.4 Running the boiler	42
	3.1 Fuel supply	10		10.5 Balancing the system	43
	3.2 Burner oil connection	12		10.6 Completion	43
4	INSTALLATION	14		10.7 Information for the user	43
	4.1 Introduction	14	11	SERVICING	44
	4.2 Boiler location	14		11.1 Checks before servicing	44
	4.3 Regulations compliance	14		11.2 Dismantling prior to servicing	44
	4.4 Heating system design considerations	14		11.3 Cleaning the boiler	44
	4.5 Pipework materials	15		11.4 Cleaning the burner:	
	4.6 Connections	15		RDB 2.2BG BLU Burners	46
	4.7 Preparation for installation	15		11.5 Cleaning the burner:	
	4.8 Installing the boiler	15		Other components	47
	4.9 Expansion vessel	15		11.6 Recommissioning	47
	4.10 Filling the heating system	16	12	FAULT FINDING	48
	4.11 Before you commission	16		12.1 Initial checklist -	
	4.12 Completion	16		For installers or service engineers	48
5	PIPE CONNECTIONS	17		12.2 Main fault finding procedures	49
	5.1 Water connections	17		12.3 Poor hot water checklist	51
	5.2 Making the water connections	18		12.4 Burner fault indication	52
	5.3 Domestic hot water system	18		12.5 Burner fault diagnosis	52
	5.4 To use the water hardness kit	18		12.6 Riello RDB BLU fault finding chart	53
6	CONDENSATE DISPOSAL	19	13	SPARE PARTS	54
	6.1 General requirements	19		13.1 Boiler parts list	54
	6.2 Connections	19		13.2 Sealed system parts list	54
	6.3 Pipework	19		13.3 Riello RDB BLU burners	55
	6.4 External pipework	19	14	DECLARATION OF CONFORMITY	57
	6.5 Condensate soakaway	20	15	HEALTH AND SAFETY INFORMATION	58
	6.6 Condensate trap	20		15.1 Insulation materials	58
	6.7 Condensate disposal pipework	20		15.2 Sealant and adhesive	58
	6.8 Inspection and cleaning of trap	20		15.3 Kerosene and Gas Oil fuels	58
	6.9 External condensate trap fitting	21	16	END OF LIFE INFORMATION	59
7	SEALED SYSTEMS	22	17	PRODUCT FICHE	60
	7.1 Sealed system requirements	22	18	GUARANTEE	61
	7.2 Filling the sealed system	23	A1	RDB BLU BURNER INFORMATION	63
	7.3 Venting the pump	23	A2	WILO YONOS PARA RS RKC CIRCULATING PUMP	67
	7.4 Pressure relief (safety) valve operation	23	A3	WILO-PARA 25-130/7-50/SC-6#GRA CIRCULATING PUMP	69
8	ELECTRICAL	24			
	8.1 General	24			
	8.2 Connecting the power supply	24			
	8.3 Connecting the controls - Heating only	25			
	8.4 Connecting the controls - Heating and hot water	25			
	8.5 Connecting an external frost thermostat	26			

1 INTRODUCTION

1.1 HOW A CONDENSING BOILER OPERATES

During the combustion process, hydrogen and oxygen combine to produce heat and water vapour. The water vapour produced is in the form of superheated steam in the heat exchanger. This superheated steam contains sensible heat (available heat) and latent heat (heat locked up in the flue gas). A conventional boiler cannot recover any of the latent heat and this energy is lost to the atmosphere through the flue.

The Grant Vortex condensing boiler contains an extra heat exchanger which is designed to recover the latent heat normally lost by a conventional boiler. It does this by cooling the flue gases to below 90°C, thus extracting more sensible heat and some of the latent heat. This is achieved by cooling the flue gases to their dew point (approximately 55°C).

To ensure maximum efficiency, the boiler return temperature should be 55°C or less, this will enable the latent heat to be condensed out of the flue gases.

- The boiler will achieve net thermal efficiencies of 100%.

To achieve maximum performance from the Grant Vortex boiler, it is recommended that the heating system is designed so that a temperature differential of 20°C between the flow and return is maintained.

The Grant Vortex boiler will however still operate at extremely high efficiencies even when it is not in condensing mode and therefore is suitable for fitting to an existing heating system without alteration to the radiator sizes. The boiler is capable of a maximum flow temperature of 75°C.

1.2 BOILER DESCRIPTION

The Grant VortexBlue Combi range of automatic pressure jet oil boilers have been designed for use with a sealed central heating system and will provide domestic hot water at mains pressure.

All boilers are supplied with the control panel and burner factory fitted.

The boilers are suitable for use in a sealed central heating system only. All combi models are supplied with the necessary components factory fitted. Refer to Section 7.

All boilers are supplied with the control panel and burner factory fitted.

All the models in the current Grant VortexBlue Combi range of boilers are designed to comply with the maximum NOx emissions* under the Energy-related Products Directive (ErP).

* From the 26th September 2018, the maximum NOx emissions for all new oil fired boilers (up to and including 400kW for both new build and replacement boiler installations) is 120mg/kWh.

1.3 FLUE OPTIONS

The boilers can be connected to either a conventional flue system or a balanced flue system, as required.

1.3.1 FOR CONVENTIONAL FLUE APPLICATIONS

Where a chimney is to be lined - Grant recommends the use of the Grant 'Orange' flue system, specifically designed for the Vortex range of condensing boilers. Refer to Section 9.2 for further details.

Where a rigid conventional flue is required, Grant recommends the use of the Grant 'Hybrid' flue system, which uses components from the Grant 'Orange' and 'Green' flue systems. Refer to Figure 9-4 for details. This flue system is suitable for all Grant VortexBlue Combi oil boilers.

The 'Orange' system flue components used for the internal part of the Hybrid system (extensions and elbows) are from the smaller 100mm size range (e.g. WE45/100 elbow, WX450/100 450mm extension, etc.) – refer to Table 9-3.

The 'Green' system twin wall flue components used for the external part of the Hybrid system are from the larger '200' size range (e.g. GTV/200B terminal, GX950/200B 950mm extension, etc.) that have a 100mm internal flue diameter – refer to Table 9-5.

The Grant flue adaptor kit (Grant product code: CFA15/70) will also be required as this contains:

- a) the flue adaptor required to connect the 'Orange' system flue components to the boiler flue outlet (no flue adaptor is supplied with the boiler).
- b) the adaptor to connect the single wall 'Orange' system flue to the twin wall 'Green' system flue.

The maximum vertical height (from the top of the boiler to the terminal) of the 'Hybrid' Green/Orange flue system is 19 metres.

! NOTE !

The flue system materials and construction MUST be suitable for use with oil-fired condensing boilers. Failure to fit a suitable conventional flue may invalidate the guarantee on the boiler.

1.3.2 FOR BALANCED FLUE APPLICATIONS

The following flue kits are available from Grant UK. Refer to Section 9.4.

Yellow system

Standard low level concentric balanced flue - components available:

- Low level concentric balanced flue kit - short and standard lengths available
- Extensions 225 mm, 450 mm and 675 mm (internal use only)
- 90° extension elbow (internal use only)
- 45° extension elbow (internal use only)
- 45° elbow (internal use only)
- Plume diverter kits

Green system

Standard external high level/vertical flue starter kit (room sealed) - components available:

- External high level/vertical flue starter kit short (room sealed)
- Extensions 150 mm, 250 mm, 450 mm, 950 mm
- Adjustable extension 195 to 270 mm
- 45° elbow
- High level terminal
- Vertical terminal

White system

High level and vertical concentric balanced flue kit - components available:

- Extensions 225 mm, 450 mm, 950 mm
- Adjustable extension 275 to 450 mm
- Vertical concentric balanced flue kit
- 45° elbow

Red system (for VortexBlue Combi 21 and 26 only)

A flexible vertical balanced flue system designed to be fitted inside an existing masonry chimney.

Consisting of three sections:

- Concentric white painted flue pipe connected to the boiler
- Vertical concentric flexible flue (flexible stainless steel flue liner inside a stainless steel air inlet liner)
- Terminal assembly for chimney top mounting

Flue extensions and 45° elbows from the White system may be used.

Fitting instructions for the Low level, High level and Vertical balanced flue systems are supplied with the kits.

1.4 BOILER COMPONENTS

All burners are pre-set for use with kerosene and are supplied ready to connect to a single pipe fuel supply system with a loose flexible fuel line and 3/8" to 1/4" BSP male adaptor supplied with the boiler.

If required, an additional flexible fuel line (900 mm in length, product code: RBS36 or 600mm in length, product code: RBS36XS) and 3/8" to 1/4" BSP male adaptor (product code: Z3003602) are available to purchase from Grant UK, for two-pipe oil supply systems.

The temperature of the water leaving the boiler to heat the radiators is user adjustable.

The setting of the boiler thermostat on the VortexBlue Combi boilers has no affect on the hot water performance.

The boiler is fitted with an overheat thermostat (which allows it to be used on a sealed central heating system) which will automatically switch off the boiler if the heat exchanger exceeds a pre-set temperature of 110°C ± 3°C.

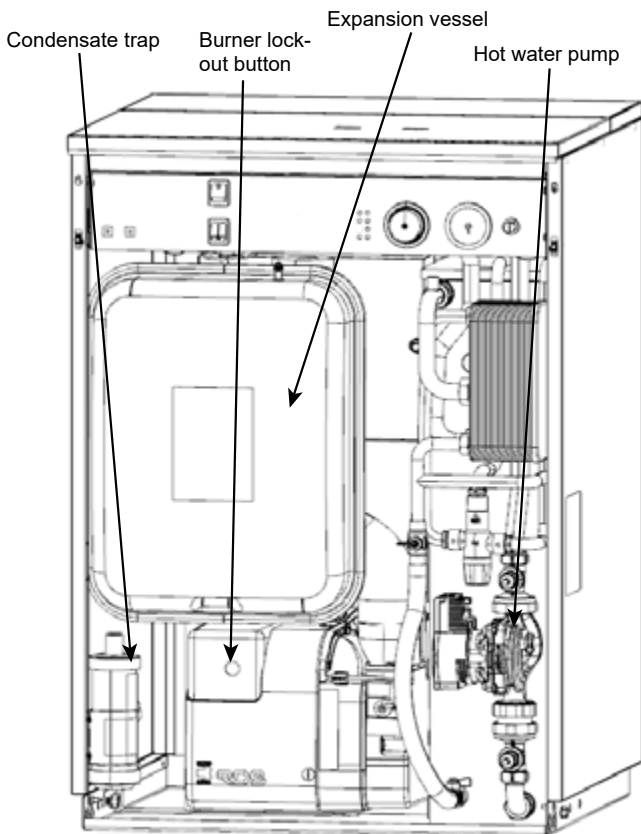

Figure 1-1: Boiler components (VortexBlue Combi 21)

Figure 1-1 shows the components in the VortexBlue Combi boilers and the position of the control panel.

Figure 1-2 shows the details of the control panel.

The control panel is fitted with an ON/OFF switch, heating switch, hot water switch, indicator lights, boiler thermostat, pressure gauge and manual reset for the overheat thermostat.

1.4.1 BOILER CONTROLS

To access the control panel, pull off the front door panel from the boiler. The controls on the panel are as follows:

Boiler On/Off switch

This switches the boiler on and off. The boiler ON/OFF switch incorporates a 'mains on' neon which lights when the boiler is switched on. Please note that the 'mains on' neon does not necessarily indicate that the burner is firing. See Boiler Indicator Lights information in the next column.

When the ON/OFF switch is set to on, the POWER indicator LED on the control panel will also light. This also does not necessarily indicate that the boiler is firing.

! NOTE !

If the ON/OFF switch is set to off the boiler will NOT supply central heating or domestic hot water. The built-in frost thermostat will also not operate.

Heating/Hot Water Switch

When set to TIMED the boiler will only provide central heating/hot water during the 'on' periods set on the timer. When set to the CONSTANT position the boiler provides central heating/hot water continuously, overriding all of the timer settings.

Heating Thermostat

This control allows the temperature of the water leaving the boiler to heat the radiators to be adjusted. This will be set by the installer to the optimum temperature for efficient operation of the boiler. It should be left set in this position.

Boiler Indicator Lights

These red LEDs, located on the boiler control panel, indicate the operating situation of the boiler as below:

PUMP	Power to the relevant circulating pump
POWER	Mains power to the boiler is switched on
FLOW	DHW flow switch has been activated.
DEMAND	Demand for heating (and/or hot water) from the heating system controls.
OVERHEAT	Boiler overheat thermostat has operated and switched the boiler off.
BURNER	Power to the burner for it to operate.

Overheat Thermostat (Overheat Reset)

The boiler is fitted with a safety overheat thermostat which will automatically switch off the boiler in the case of a control malfunction causing overheating.

System Pressure Gauge

This is to indicate the water pressure in the sealed heating system.

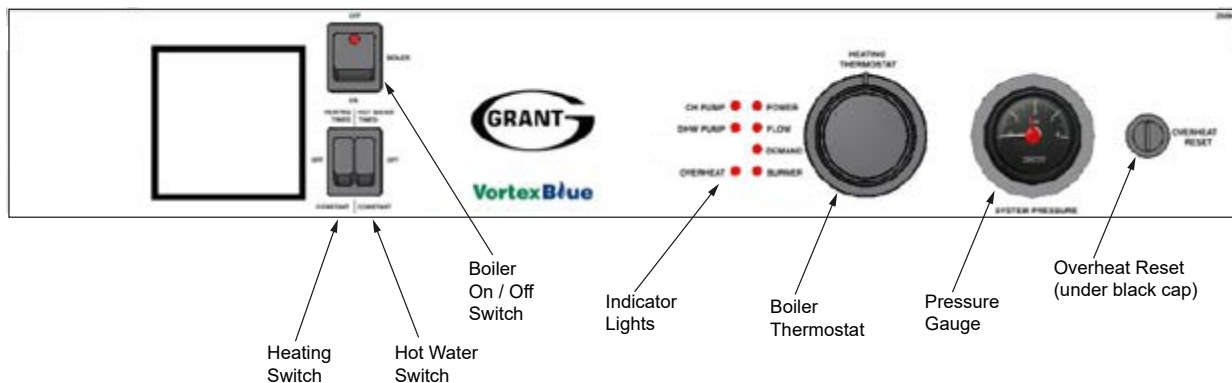

Figure 1-2: VortexBlue Combi boiler control panel

2 TECHNICAL DATA

2.1 BOILER TECHNICAL DATA

Table 2-1: Boiler technical data

	Units	VortexBlue Internal Combi 21	VortexBlue Internal Combi 26	VortexBlue Internal Combi 36
Water content (including 32 litre primary store)	litre	48.5	48.5	53.5
	gal	10.7	10.7	11.8
Weight (dry) *	kg	160	177	200
	lb	353	390	441
Maximum heat output (Kerosene)	kW	21.0	26.0	36.0
	Btu/h	71,700	88,700	123,000
Heating system flow and return connections	mm	22	22	28
Cold water mains inlet	mm	15	15	22
Domestic hot water outlet	mm	15	15	22
Minimum flow rate ($\Delta T=10^{\circ}\text{C}$)	l/h	1,800	2,200	3,000
Minimum flow rate ($\Delta T=20^{\circ}\text{C}$)	l/h	900	1,100	1,500
Pressure relief valve discharge	mm	15		
Minimum heating system pressure (cold) **	bar	1.5		
Expansion vessel (pre-charged at 1 bar)	litres	24		
Maximum heating system volume ***	litres	105	105	100
Minimum domestic hot water flow rate		3.0 litres/min (0.66 gal/min)		
Maximum domestic hot water temperature	$^{\circ}\text{C}$	65 (factory set)		
Maximum mains water inlet pressure	bar	8.0		
Minimum recommended mains water inlet pressure	bar	2.5		
Condensate connection		22 mm (only connect plastic pipe)		
Flue diameter (conventional)	mm	100		
Waterside resistance $\Delta T=10^{\circ}\text{C}$	mbar	28.5		26.0
Waterside resistance $\Delta T=20^{\circ}\text{C}$	mbar	10.0		9.5
Maximum static head	m	28		
Minimum circulating head	m	1		
Boiler thermostat range	$^{\circ}\text{C}$	65 to 75		
Limit (safety) thermostat shut off temperature	$^{\circ}\text{C}$	110 \pm 3		
Maximum hearth temperature	$^{\circ}\text{C}$	Less than 50		
Electricity supply		~230 1ph 50Hz 5A fused		
Burner motor power	Watts	90		
Absorbed motor power	kW	0.15		
Starting current	Amps	2.0		
Running current	Amps	0.85		
Oil connection		1/4" BSP male (on end of flexible fuel hose)		
Conventional flue draught	mbar	Minimum: 0.087 - Maximum: 0.37		
	in wg	Minimum: 0.035 - Maximum: 0.15		
Maximum operating pressure - sealed/open system	bar	2.0		
Maximum operating pressure - pressure relief valve	bar	3.0		
Boiler type		ON/OFF		

* Weight includes burner (and expansion vessel) but excludes flue

** Refer to Section 7.2 for further information on filling the system.

*** Based on expansion vessel charge of 1.3 bar and initial cold system pressure of 1.5 bar. These values are the remaining system volume available after deducting the boiler water content.

2.2 BURNER SETTINGS

Table 2-2: Burner settings

Boiler models (burner type)	Heat output		Nozzle	Oil pressure (bar)	Smoke No.	Burner head type	Fuel flow rate (kg/h)	Flue gas temp. (°C)	CO ₂ (%)	Flue gas VFR ‡ (m ³ /hr)
	(kW)	(Btu/h)								
VortexBlue Internal Combi 21 (RDB2.2 BG1 BLU 21)	21.0	71,700	0.60/80°ES	8.5	0 - 1	BG1	1.75	70 - 80	12.0	23.0
VortexBlue Internal Combi 26 (RDB2.2 BG2 BLU 26)	26.0	88,700	0.65/80°ES	10.0	0 - 1	BG2	2.16	75 - 80	12.0	28.5
VortexBlue Internal Combi 36 (RDB2.2 BG3 BLU 36)	31.5*	107,500	0.85/80°ES	9.0	0 - 1	BG3+	2.62	70 - 75	12.0	34.5
	36.0	123,000	0.85/80°ES	11.0	0 - 1	BG3+	2.99	75 - 80	12.0	39.5

Notes:

‡ Flue gas VFR: Flue gas volumetric flow rate

1. The data given above is approximate only and is based on the boiler being used with a low level balanced flue.

2. The above settings may have to be adjusted on site for the correct operation of the burner.

3. Gas Oil is NOT suitable for use with Grant Vortex boiler range

4. The flue gas temperatures given above are ± 10%.

5. When commissioning, the air damper **must be** adjusted to obtain the correct CO₂ level.

6. * Factory settings: Combi 36 - 31.5 kW.

7. The combustion door test point may be used for CO₂ and smoke readings only. Do not use this test point for temperature or efficiency readings.

8. The installer must amend the boiler data label if the output is changed.

2.3 FLUE GAS ANALYSIS

To allow the boiler to be commissioned and serviced, the boiler is supplied with a combustion test point on the front cleaning door.

When this test point is used please note the following:

- The test point is for CO₂ and smoke readings only.
- The boiler efficiency and temperature must be taken from the flue test point on high level, vertical and conventional flue adaptors.
- Concentric low level flues do not contain a test point. The temperature and efficiency readings must be taken from the flue terminal.

2.4 BOILER DIMENSIONS

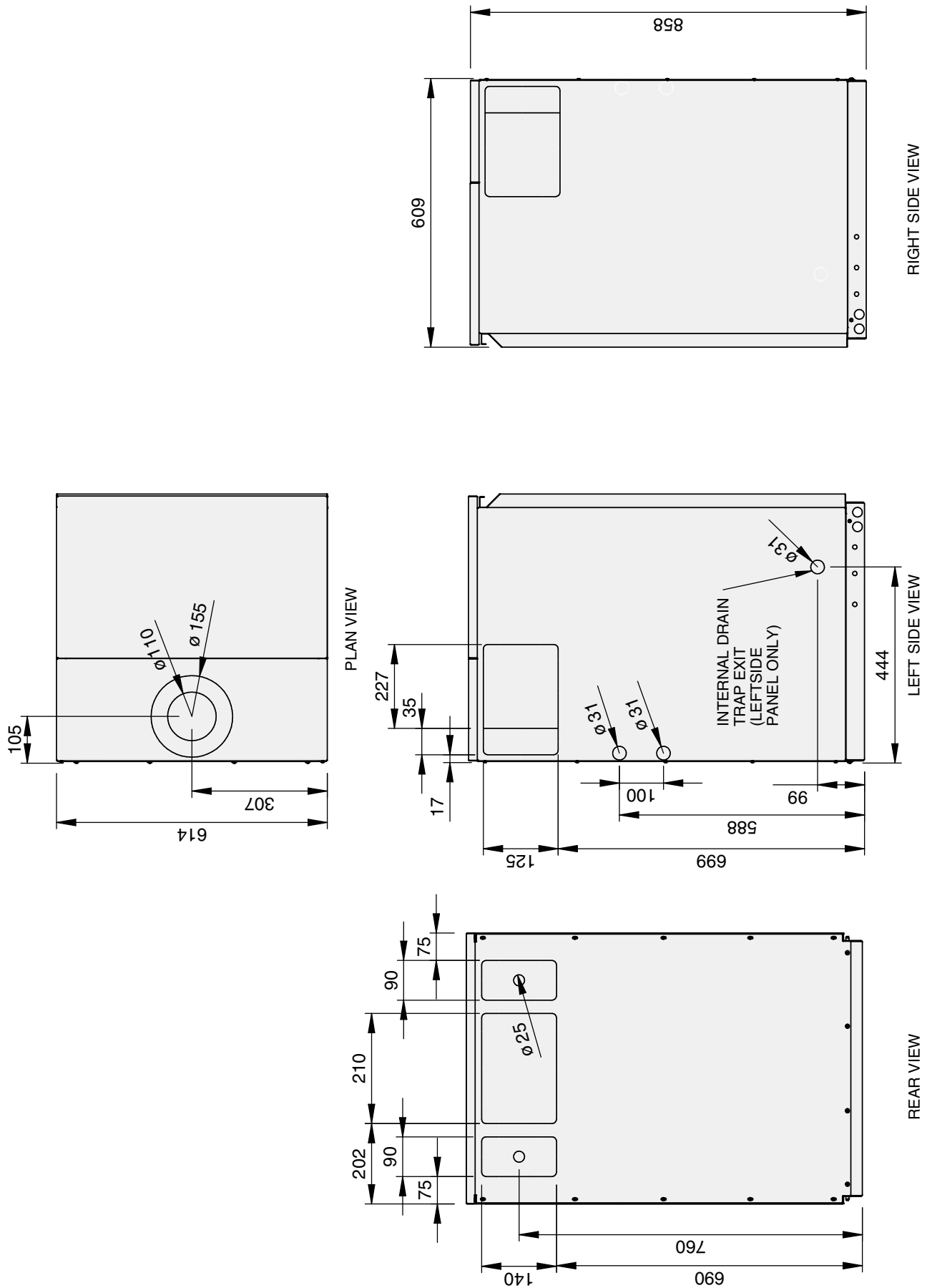

Figure 2-1: VortexBlue Combi Internal 21 and 26 dimensions

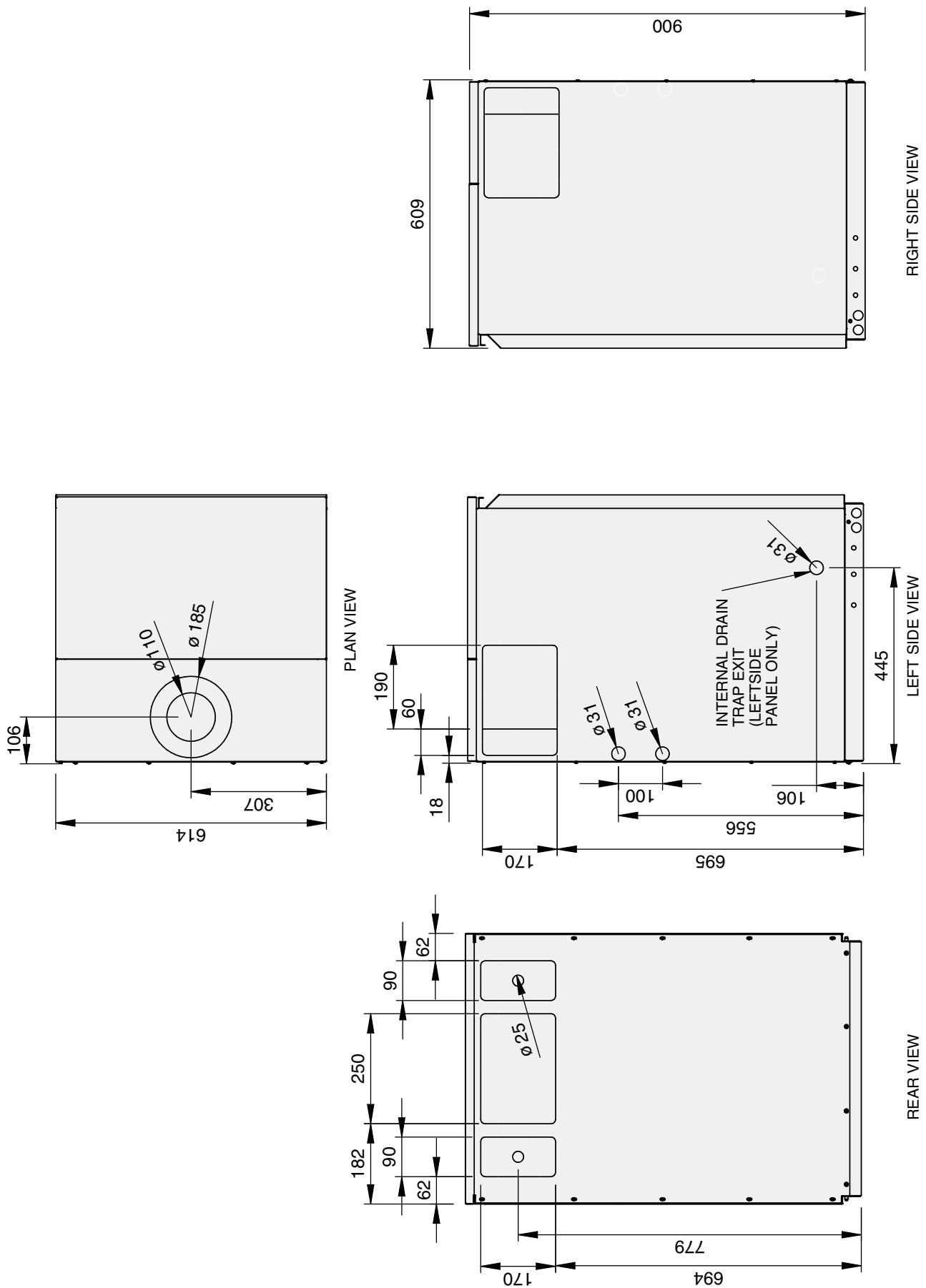

Figure 2-2: VortexBlue Combi Internal 36 dimensions

3 OIL STORAGE AND SUPPLY SYSTEM

3.1 FUEL SUPPLY

3.1.1 FUEL STORAGE

The tank should be positioned in accordance with the recommendations given in BS 5410-1 (Code of practice for liquid fuel firing. Installations for space heating and hot water supply purposes for domestic buildings). This gives details of the requirements for suitable oil tank construction, tank installation, tank bases, fire protection and secondary containment.

For installations of greater than 70kW output capacity, the tank should be installed accordance with BS 5410-2.

Oil storage tanks should comply with the following standards:

- Plastic tanks OFT T100
- Steel tanks OFT T200

! CAUTION !

A galvanised tank must not be used.

! NOTE !

Plastic tanks should be stood on a firm non-combustible base that adequately and uniformly supports the weight of the tank over its entire base area.

The tank capacity should be selected to suit the appliance rated output. Refer to BS5410-1 for guidance.

3.1.2 FUEL PIPES

Fuel supply pipes should be either copper or steel. Galvanised pipes or fittings should not be used.

Plastic oil supply pipe conforming to BS EN 14125 can be used for underground pipe runs, but must not be used above ground.

All soft copper pipe connections should preferably be made using flared fittings. If compression fittings are to be used, a suitable pipe insert must be fitted into the pipe end.

Soft soldered connections must NOT be used on oil supply pipework.

Fuel supply pipework should be of a suitable diameter, depending on the type of oil supply system being used. Refer to information given in sections 3.1.3, 3.1.4 or 3.1.5.

Run pipes as level as possible to prevent air being trapped. Take the most direct route possible from tank to burner whilst locating the pipe where it will be protected from damage.

Pipes should be supported to prevent sagging and sleeved where they pass through a wall.

A metal body fuel filter with a filtration size of no more than 50 µm (micron) must be fitted in the oil supply pipe close to the tank. This should be fitted with sufficient clearance around and below it to allow easy access for maintenance.

An isolating valve should also be fitted at the tank, before the filter, to allow the oil supply to be shut off for the filter to be serviced.

A second filter (15 µm for Kerosene) must be located closer to the burner to protect the burner pump and nozzle from contamination. Refer to Figures 3-1 to 3-3.

A remote sensing fire valve must be installed in the fuel supply line in accordance with BS5410-1.

A fusible wheelhead type combined isolating/fire valve MUST NOT be used in place of a remote sensing fire valve.

The fire valve must be located outside; just before the oil line enters the building, with the fire valve sensor located above the burner.

A spring clip for mounting the sensor is supplied fitted to the boiler, on the rear of the control panel.

The fire valve should be located after the second (15 micron) filter, i.e. between the filter and the point at which the oil line enters the building. Refer to Figures 3-1 to 3-3.

The fire valve must have an operating temperature of between 90 and 95°C to avoid unnecessary nuisance shut-offs to the oil supply.

A flexible fuel hose and ¼" isolating valve are supplied loose with the boiler, to make the final connection to the burner.

If a two-pipe system or deaerator is to be used, the following additional items will be required:

- Flexible fuel hose ¾" male x ¼" female (product code: RBS36 - 900 mm / product code: RBS36XS - 600mm)
- ¾" x ¼" BSP adaptor (product code: Z3003602)
- ¼" isolating valve (product code: ISOLATION1/4)

These are available to purchase from Grant UK.

Metal braided flexible fuel hoses should be replaced ANNUALLY when the boiler is serviced.

Long life flexible fuel hoses should be inspected annually and replaced, if necessary, or after a maximum five years service life.

Flexible fuel hoses MUST NOT be used outside of the appliance casing.

3.1.3 SINGLE PIPE (GRAVITY) SYSTEM - (REFER TO FIGURE 3-1)

Head A (m)	Maximum pipe run (m)	
	10 mm OD pipe	12 mm OD pipe
0.5	10	20
1.0	20	40
1.5	40	80
2.0	60	100

If the storage tank outlet is at least 300 mm above the level of the burner oil pump, a single pipe (gravity) system should be used.

The maximum height of the oil level above the burner oil pump when the tank is full, must not exceed four metres. If this height is exceeded, a pressure reducing valve must be fitted in the oil supply pipe between the tank and the burner oil pump.

The maximum length of pipe run from the tank to the burner is limited by the minimum head of oil (the height of the tank tank outlet above the burner oil pump).

3.1.4 TWO PIPE SYSTEM - (REFER TO FIGURE 3-2)

Head A (m)	Maximum pipe run (m)	
	10 mm OD pipe	12 mm OD pipe
0	35	100
0.5	30	100
1.0	25	100
1.5	20	90
2.0	15	70
3.0	8	30
3.5	6	20

If the storage tank outlet is below the level of the burner oil pump, a two pipe (sub gravity) system can be used.

The return pipe should be at the same level as the tank outlet, between 75 to 100 mm above the base of the tank. The return pipe should be a sufficient distance from the tank outlet so as to prevent any sediment disturbed by the return entering the supply pipe from the tank.

A non-return valve should be fitted in the supply pipe, along with a fire valve and filters (refer to section 3.1.2 - fuel pipes). A non-return valve should also be fitted in the return pipe if the top of the tank is above the burner oil pump.

The maximum suction height (from the tank outlet to the level of the burner oil pump), must not exceed 3.5 metres.

The pump vacuum should not exceed 0.4 bar. Beyond this limit, gas is released from the oil.

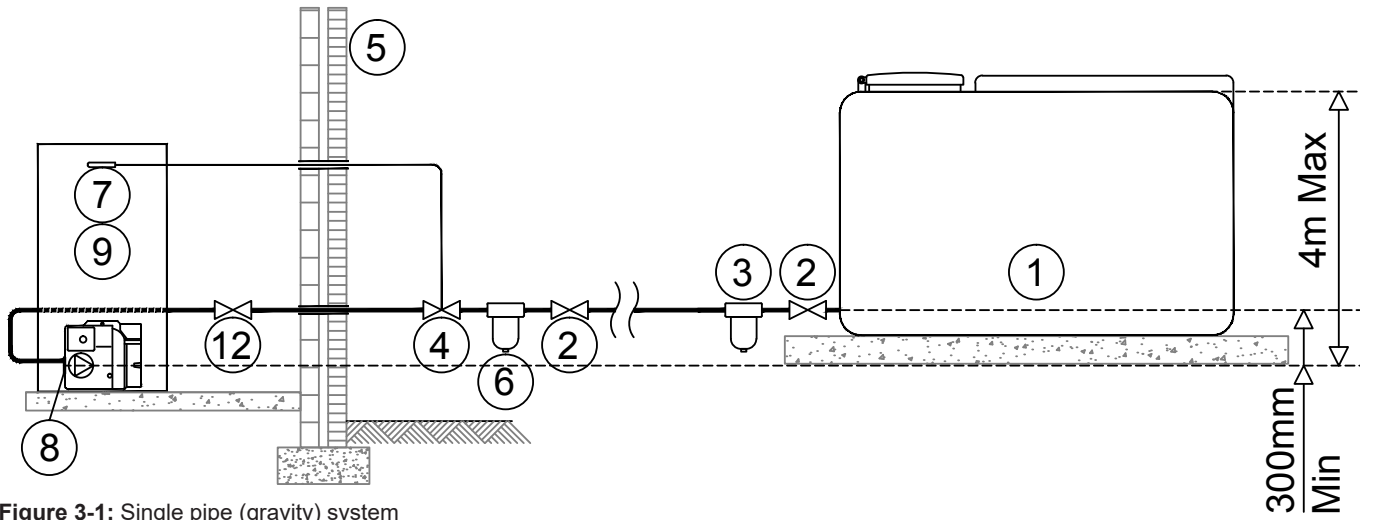

Figure 3-1: Single pipe (gravity) system

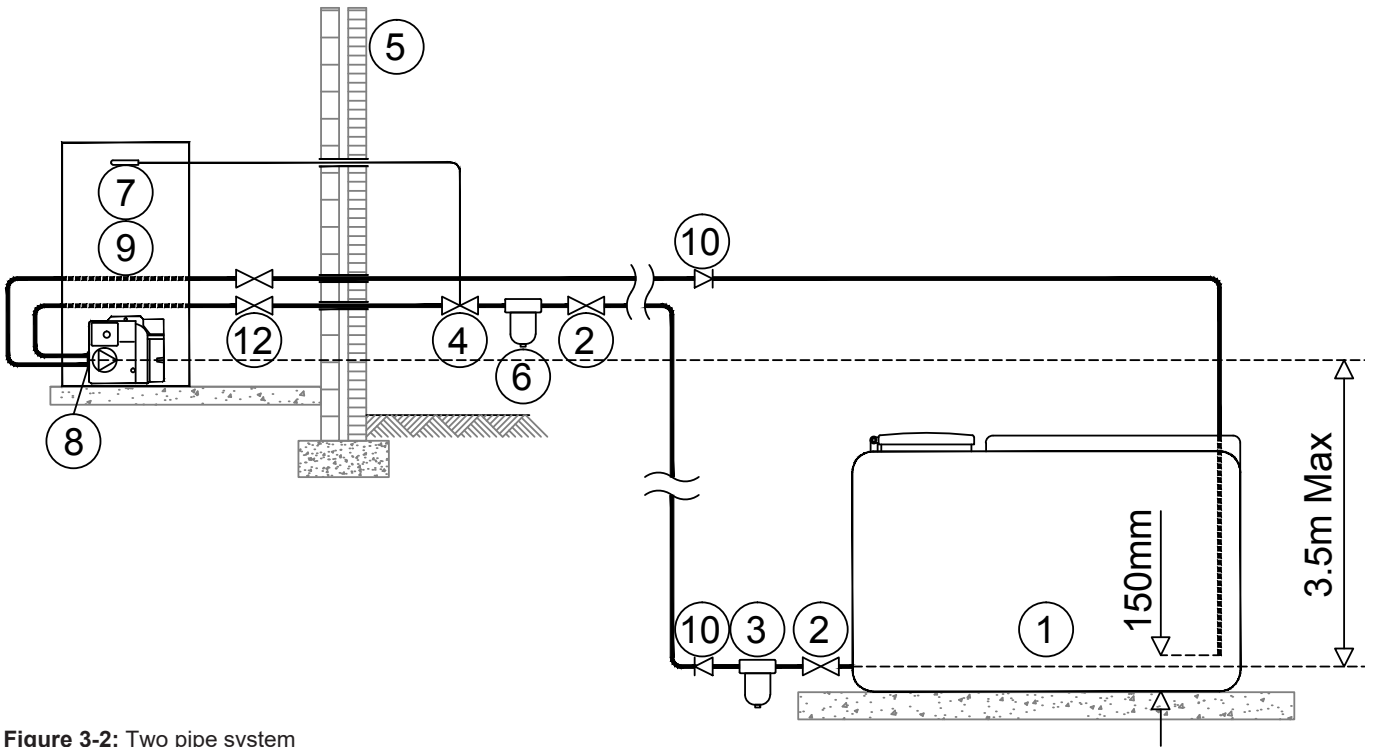

Figure 3-2: Two pipe system

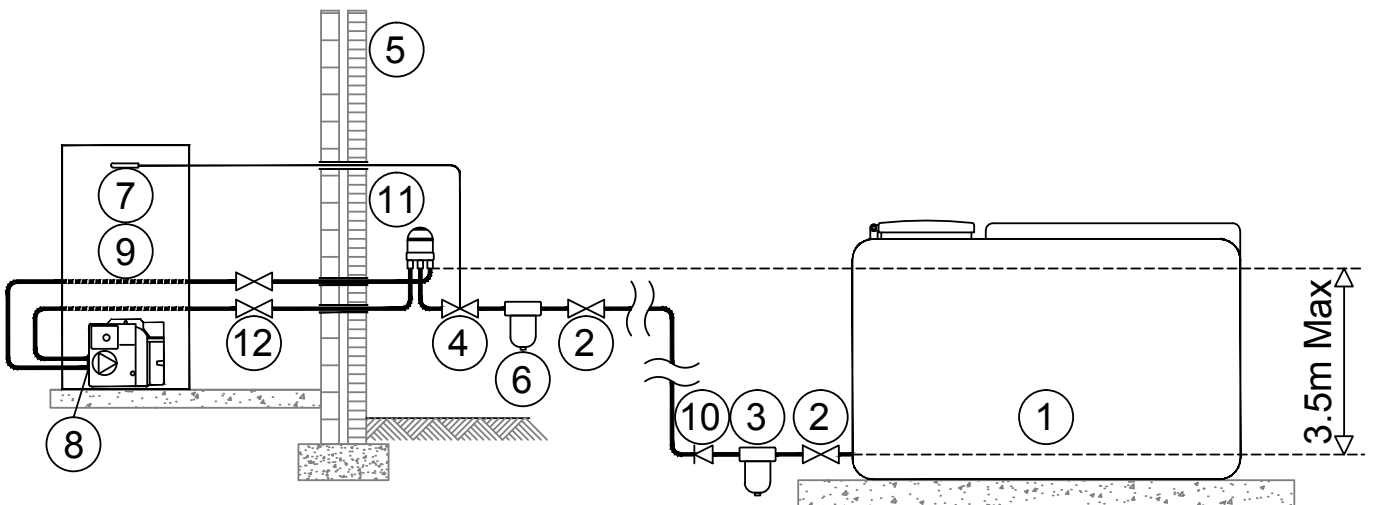

Figure 3-3: De-aeration device system

Key to oil supply diagrams

1	Oil tank	5	External wall	9	Burner
2	Isolating valve	6	Oil filter (15µm max. filtration size)	10	Non-return valve
3	Oil strainer	7	Fire valve sensor	11	De-aerator*
4	Fire valve to BS5410-1	8	Oil pump	12	Appliance isolation valves

* Position of de-aeration device must be level with or above the oil pump

For guidance on the installation of top outlet fuel tanks and suction oil supply pipe sizing, refer to OFTEC Technical Book 3: Storage and Supply, available for purchase from OFTEC.

If a two-pipe system is to be used, the following additional items will be required:

- Flexible fuel hose 3/8" male x 1/4" female (product code: RBS36 - 900 mm / product code: RBS36XS - 600mm)
- 3/8" x 1/4" BSP adaptor (product code: Z3003602)
- 1/4" isolating valve (product code: ISOLATION1/4)

These are available to purchase from Grant UK.

3.1.5 SINGLE PIPE (SUCTION) SYSTEM WITH DEAERATOR - (REFER TO FIGURE 3-3)

If the storage tank outlet is below the level of the burner oil pump, an alternative to the two pipe (sub gravity) system is the single pipe (suction) system using a deaerator, e.g. a 'Tiger Loop' device.

The deaerator creates a loop with the burner oil pump, with the oil being circulated through the pump out to the deaerator and back to the pump. Any air in the single pipe lift from the tank is removed from the oil, collected in the deaerator and then discharged to outside.

! WARNING !

To prevent any fuel vapour being discharged within the building, the deaerator must be fitted outside, in accordance with BS 5410-1, unless it is specifically designed to be installed inside.

The de-aerator must be mounted vertically at the same level as (or above) the burner oil pump. Refer to Figure 3-3.

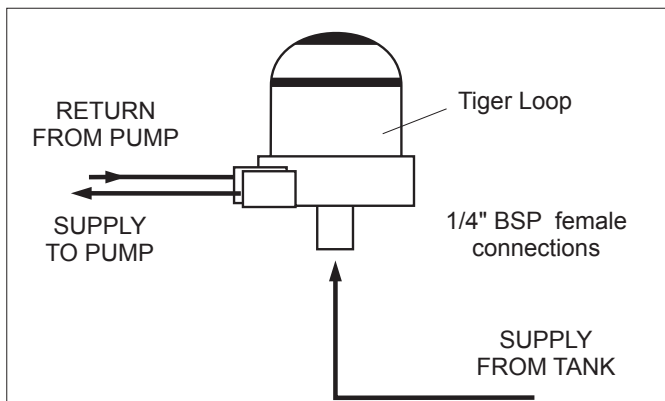

Figure 3-4: Tiger loop de-aeration device

An external deaerator must not be fitted within 500 mm of a flue terminal.

Always follow the manufacturers installation instructions supplied with the deaerator.

To use a de-aerator, the following additional items will be required:

- Flexible fuel hose 3/8" male x 1/4" female (product code: RBS36 - 900 mm / product code: RBS36XS - 600mm)
- 3/8" x 1/4" BSP adaptor (product code: Z3003602)
- 1/4" isolating valve (product code: ISOLATION1/4)

These are available to purchase from Grant UK.

3.2 BURNER OIL CONNECTION

! WARNING !

The blanking plug supplied in the inlet (suction) port is plastic and will not provide an oil tight seal when the pump is running.

Ensure that the supply from the tank is connected to this port and that the plastic plug is discarded.

The burner fuel pump is supplied factory set for use with a single pipe (gravity) oil supply system.

For ease of access to the burner oil pump connections, the burner should be removed from the boiler as follows:

1. Remove the red plastic burner cover.
 - Unscrew and remove the TWO fixing screws from the stud on the burner flange and remove the cover from the burner.
2. Unscrew and remove the single burner fixing nut from the stud on the burner flange (at the top of the burner) using a 13 mm spanner. Retain the fixing nut for re-fitting the burner.
3. Carefully withdraw the burner from the boiler.

3.2.1 SINGLE PIPE (GRAVITY) CONNECTION - REFER TO FIGURE 3-5

Connect the oil supply to the burner oil pump as follows:

1. Unscrew and remove the plastic blanking plug from the suction port of the burner oil pump and discard it.
2. Fit the nut of the elbow connection on the flexible fuel hose (supplied with the boiler) into the suction port and tighten.
3. Fit the 1/4" isolating valve (supplied with the boiler) to the end of the rigid oil supply pipe using a fitting to suit the pipe size and type (not supplied).
4. Connect the other end of the flexible fuel hose to the isolating valve using the 3/8" x 1/4" BSP adaptor (supplied with the boiler).
5. Re-fit the burner to the boiler.

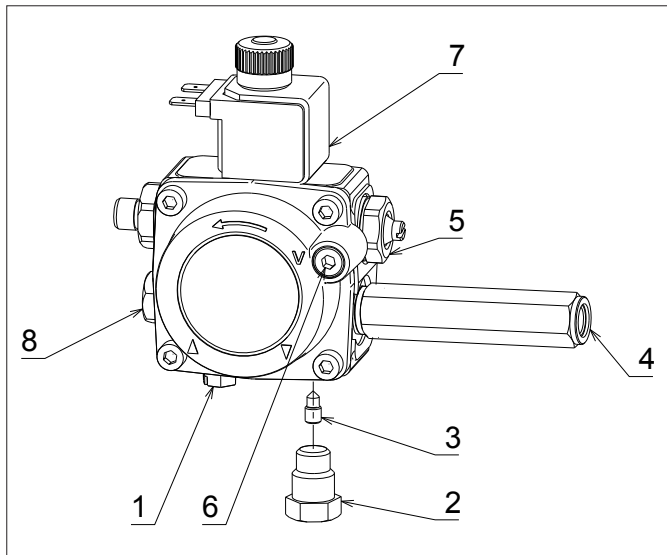

Figure 3-5: Riello RDB pump

Figure 3-6: Key to Riello RDB pump

Item	Description
1	Inlet (suction) port
2	Return port
3	By-pass screw
4	Pressure gauge port
5	Pressure adjustment
6	Vacuum gauge port
7	Solenoid
8	Auxiliary pressure test point

3.2.2 TWO PIPE CONNECTION

For either a two pipe (sub gravity) or a single pipe (suction) system with a deaerator, the following additional items will be required:

- Flexible fuel hose $\frac{3}{8}$ " male x $\frac{1}{4}$ " female (product code: RBS36 - 900 mm / product code: RBS36XS - 600mm)
- $\frac{3}{8}$ " x $\frac{1}{4}$ " BSP adaptor (product code: Z3003602)
- $\frac{1}{4}$ " isolating valve (product code: ISOLATION1/4)

These are available to purchase from Grant UK.

Connect the oil supply to the burner oil pump as follows:

1. Fit the flexible fuel hose (supplied with the boiler) to the suction port of the burner oil pump, as detailed in Section 3.2.1.

With either a two pipe (sub gravity) system or a single pipe (suction) system with a deaerator, the by-pass screw (supplied with the boiler) must be fitted to the burner oil pump as follows:

1. Unscrew and remove the blanking plug from the return port on the burner oil pump and discard it.
2. Fit the by-pass screw into the threaded hole (inside the return port) and fully screw it in using an allen key.
3. Fit the nut of the elbow connection on the flexible fuel hose into the return port and tighten.
4. Fit the $\frac{1}{4}$ " isolating valve (not supplied) to the end of the rigid oil return pipe (to the deaerator or oil tank) using a fitting to suit the pipe size and type (not supplied).
5. Connect the other end of the flexible fuel hose (not supplied) to the isolating valve using a $\frac{3}{8}$ " x $\frac{1}{4}$ " BSP adaptor (not supplied).
6. Re-fit the burner to the boiler.

4 INSTALLATION

4.1 INTRODUCTION

The boiler is supplied already fully assembled in a carton which is carefully packed with packing materials. The installation procedure therefore begins with unpacking of the packed boiler.

4.2 BOILER LOCATION

The boiler must stand on a firm and level surface capable of supporting the boiler when full of water. Refer to Section 2.1 for weights.

It does not require a special hearth as the temperature of the boiler base is less than 50°C.

Sufficient clearance must be allowed at the front of the boiler to remove the burner and baffles for servicing.

All VortexBlue Combi boilers can be serviced from the front, but it is preferable for any worktop above the boiler to be removable.

Care should be taken when siting the condensate trap if it is to be fitted outside the boiler. Refer to Section 6.9.

4.3 REGULATIONS COMPLIANCE

! NOTE !

Failure to install and commission appliances correctly may invalidate the boiler guarantee.

Installation of a Grant Vortex boiler must be in accordance with the following recommendations:

- Building Regulations for England and Wales, and the Building Standards for Scotland issued by the Department of the Environment and any local Byelaws which you must check with the local authority for the area.
- Model and local Water Undertaking Byelaws.
- Applicable Control of Pollution Regulations.
- National Building Regulations and any local Byelaws.
- Model Byelaws and the Water Supply Regulations.
- The following OFTEC requirements:
 - OFS T100 Polythene oil storage tanks for distillate fuels.
 - OFS T200 Fuel oil storage tanks and tank bunds for use with distillate fuels, lubrication oils and waste oils.Further information may be obtained from the OFTEC Technical Book 3 (Installation requirements for oil storage tanks) and OFTEC Technical Book 4 (Installation requirements for oil fired boilers).

The installation should also be in accordance with the latest edition of the following British Standard Codes of Practice (and any relevant amendments):

- BS 5410-1: 2019 (Code of practice for liquid fuel firing. Installations for space heating and hot water supply purposes for domestic buildings)
 - This standard covers domestic installations up to 70kW.
- BS 5410-2: 2018 (Code of practice for liquid fuel firing. Non-domestic installations)
 - This standard should be followed with regard to installations with an output capacity in excess of 70kW.
 - Where the combined outputs of multiple appliances located together at a domestic dwelling exceed 70kW then then a dedicated plant room as specified in BS 5410-2 is recommended.
- BS EN 12828 (Heating systems in buildings. Design for water-based heating systems)
- BS EN 12831-1 (Energy performance of buildings. Method for calculation of the design heat load)
- BS EN 14336 (Heating systems in buildings. Installation and commissioning of water based heating systems)
- BS 7593 (Code of Practice for treatment of water in domestic hot water central heating systems)
- BS 7671 (Requirements for Electrical installations, IET Wiring Regulations)

- BS 7291 (Thermoplastics pipe and fitting systems for hot and cold water for domestic purposes and heating installations in buildings. General requirements)
- BS 7074-1 (Application, selection and installation of expansion vessels and ancillary equipment for sealed water systems. Code of practice for domestic heating and hot water supply)
- BS 2869 (Fuel oils for agricultural, domestic and industrial engines and boilers. Specification)

! WARNING !

BS5410-1: 2019 requires that appliances located in a building or structure or within a restricted area externally should have a CO detector conforming to BS EN 50291-1 installed in the same room/space.

4.4 HEATING SYSTEM DESIGN CONSIDERATIONS

! WARNING !

Before starting any work on the boiler or fuel supply, please read the Health and Safety information given in Section 15.

To achieve the maximum efficiency possible from the Grant Vortex boiler, the heating system should be designed to the following parameters:

RADIATORS:

- Flow temperature 70°C
- Return temperature 50°C
- Differential 20°C

Size radiators with a mean water temperature of 60°C.

Design system controls with programmable room thermostats or use weather compensating controls to maintain return temperatures below 55°C.

! NOTE !

The boiler should not be allowed to operate with return temperatures of less than 40°C when the system is up to temperature.

The use of a pipe thermostat is recommended to control the re- turn temperature when using weather compensating controls.

UNDERFLOOR:

- Flow temperature 50°C
- Return temperature 40°C
- Differential 10°C

In underfloor systems, it is essential that the return temperature must be maintained at or above 40°C to prevent internal corrosion of the boiler water 'primary' jacket.

Refer to Table 2-1 for the size and type of the connections and Section 5 for the position of the connections.

4.5 PIPEWORK MATERIALS

The Grant Vortex boiler is compatible with both copper and plastic pipe. Where plastic pipe is used it must be of the oxygen barrier type and be the correct class (to BS 7291-1) for the application concerned.

On either sealed or open-vented systems; where plastic pipe is used a minimum of ONE metre of copper pipe (or as per pipe manufacturers instructions) MUST be connected between both the boiler flow and return connections and the plastic pipe.

! NOTE !

Do not connect plastic pipe directly to the boiler.

Grant UK does not accept any responsibility for any damage, however caused, to plastic piping or fittings.

SEALED SYSTEMS

If plastic pipe is to be used, the installer must check with the plastic pipe manufacturer that the pipe to be used is suitable for the temperature and pressures concerned.

Plastic pipe must be Class S to BS 7291-1.

! WARNING !

When plastic pipe is used, the system MUST incorporate a low pressure switch to shut off power to the boiler if the system pressure drops below 0.2 bar. A suitable low pressure switch kit is available to purchase from Grant UK (product code: MPCBS62).

UNDERFLOOR PIPEWORK

Plastic pipe may be used on underfloor floor systems where the plastic pipe is fitted after the thermostatic mixing valve. Copper tube must be used for at least the first metre of flow and return primary pipework between the boiler and the underfloor mixing/blending valves.

4.6 CONNECTIONS

4.6.1 FLOW, RETURN AND HOT WATER CONNECTIONS

Refer to Section 5.

4.6.2 CONDENSATE CONNECTION

The condensate trap is supplied loose in the burner box and needs to be fitted as shown in Figure 6-2.

Refer to Section 6 for details of the condensate disposal pipework.

4.6.3 DRAIN COCK

A drain cock is fitted at the bottom on the front of the boiler to allow the heating system to be drained.

There is also a drain cock fitted at the bottom on the front of the primary store.

4.7 PREPARATION FOR INSTALLATION

1. Carefully remove the packaging from the boiler and remove it from the transit pallet.
2. Pull off the boiler front panel and remove the literature pack.
3. Lift off the two parts of the case top and remove the water connecting fittings.

4.8 INSTALLING THE BOILER

1. Having decided upon the position of the boiler and type of flue, prepare the wall as described in Section 9. Ensure that the flue terminal position complies with the necessary clearances.
2. Make the water connections as described in Section 5. If access will be restricted, make any connections to the boiler before placing it in its final position. Refer to Section 7 for information regarding sealed systems.

! NOTE !

If using a balanced flue system - install the balanced flue system before connecting the heating system pipework to the boiler. Once the flue system is fitted then complete the water connections and fill the heating system.

3. Ensure the requirements are met for the disposal of condensate as described in Section 6.
4. Connect the power supply as described in Section 8.
5. Connect the flue and ensure there is an adequate air supply as described in Section 9.

4.9 EXPANSION VESSEL

The Combi 21, Combi 26 and Combi 36 models are supplied with a 24 litre expansion vessel located in the front of the boiler.

Should it be required, the expansion vessel can be relocated. If this option is chosen, the vessel must be connected to the heating system by using a suitable fitting (not supplied), via the flexible hose, in a convenient position where it can be readily accessed for servicing.

The expansion vessel fitted is supplied with a charge pressure of 1.0 bar (equivalent to a maximum static head of 10.2 metres), however this charge pressure must be increased to 1.3 bar to suit the cold system fill pressure of 1.5 bar. Refer to Section 7.2 for further details.

The charge pressure must not be less than the actual static head at the point of connection.

Do not pressurise the vessel above 1.5 bar.

! NOTE !

The air pressure in the vessel must be checked annually. The central heating system volume, using the expansion vessel as supplied, must not exceed the recommended volumes. Refer to Section 2.1. If the system volume is greater, an extra expansion vessel (complying with BS 4841) must be fitted as close as possible to the central heating return connection on the boiler. The charge pressure of the extra vessel must be the same as the vessel fitted in the boiler.

Refer to BS 7074-1 for further guidance.

The air charge pressure may be checked using a tyre pressure gauge on the expansion vessel Schraeder valve.

The vessel may be re-pressurised using a suitable pump. When checking the air pressure the water in the heating system must be cold and the system pressure reduced to zero.

4.10 FILLING THE HEATING SYSTEM

Refer to Section 7.2 (Filling the Sealed System).

4.11 BEFORE YOU COMMISSION

To avoid the danger of dirt and foreign matter entering the boiler the complete heating system should be thoroughly flushed out – both before the boiler is connected and then again after the system has been heated and is still hot. This is especially important where the boiler is to be installed on an older system.

For optimum performance after installation, the boiler and the associated heating system must be flushed in accordance with the guidelines given in BS 7593 (Treatment of water in domestic hot water central heating systems). This must involve the use of a proprietary cleaner, such as Sentinel X300 (new systems), Sentinel X400 (existing systems), or Fernox Restorer.

After cleaning, it is vitally important that all traces of the cleaner are thoroughly flushed from the system.

For long term protection against corrosion and scale, after cleaning/flushing a suitable inhibitor should be added to the system water, such as Sentinel X100 or Fernox MB-1, in accordance with the manufacturers' instructions.

Failure to follow the above will invalidate the guarantee.

If the boiler is installed in a garage or out house, in order to provide further protection should there be a power failure in cold weather, a combined anti-freeze and corrosion inhibitor can be used such as Sentinel X500 or Fernox Alphi-11. Follow the manufacturers' instructions supplied to achieve the level of anti-freeze protection required.

For details of the Sentinel Products visit www.sentinel-solutions.net and for Fernox products visit www.fernox.com.

Grant UK strongly recommends that a Grant Mag One in-line magnetic filter/s (or equivalent*) is fitted in the heating system pipework. This should be installed and regularly serviced in accordance with the filter manufacturer's instructions.

* As measured by gauss. The MagOne magnetic filter has a gauss value of 12000.

4.12 COMPLETION

Following installation of the boiler, instruct the user in the operation of the boiler, the boiler controls, the heating controls and the safety devices.

Please ensure that the OFTEC CD/10 installation completion report (provided with the boiler) is completed in full, leaving the top copy with the user and retain the carbon copy for your own records.

Ensure that the User Handbook (supplied with the boiler) is handed over to the user.

5 PIPE CONNECTIONS

5.1 WATER CONNECTIONS

Water connections may be from the rear, left or right hand side. If using low level side exit flue, connections must be on the opposite side to the flue.

FLOW AND RETURN CONNECTIONS

All models are supplied with a push-fit elbow connection for the heating flow and return:

- Combi 21 and 26 - 22 mm
- Combi 36 - 28 mm

HOT WATER CONNECTIONS

All models are supplied with push-fit elbow connections for the cold water mains inlet pipe and hot water outlet pipe:

- Combi 21 and 26 - 15 mm
- Combi 36 - 22 mm

! CAUTION !

All pipes to be fitted into the push-fit connectors provided should be cut using a pipe slicer or pipe cutter - to leave the pipe ends with a slight radius and free from any burrs or sharp edges.

Pipes to be used with these fittings should not be cut square using a hacksaw.

ALL MODELS

A 15 mm discharge pipe must be connected to the safety valve outlet connection. The pipework between the safety valve and the boiler must be unrestricted, that is, no valves. The discharge pipe should be run to the outside of the building and terminate so that it cannot cause injury to persons or property.

A drain tap is provided at the bottom on the front of the boiler (and also on the hot water store on the VortexBlue Combi).

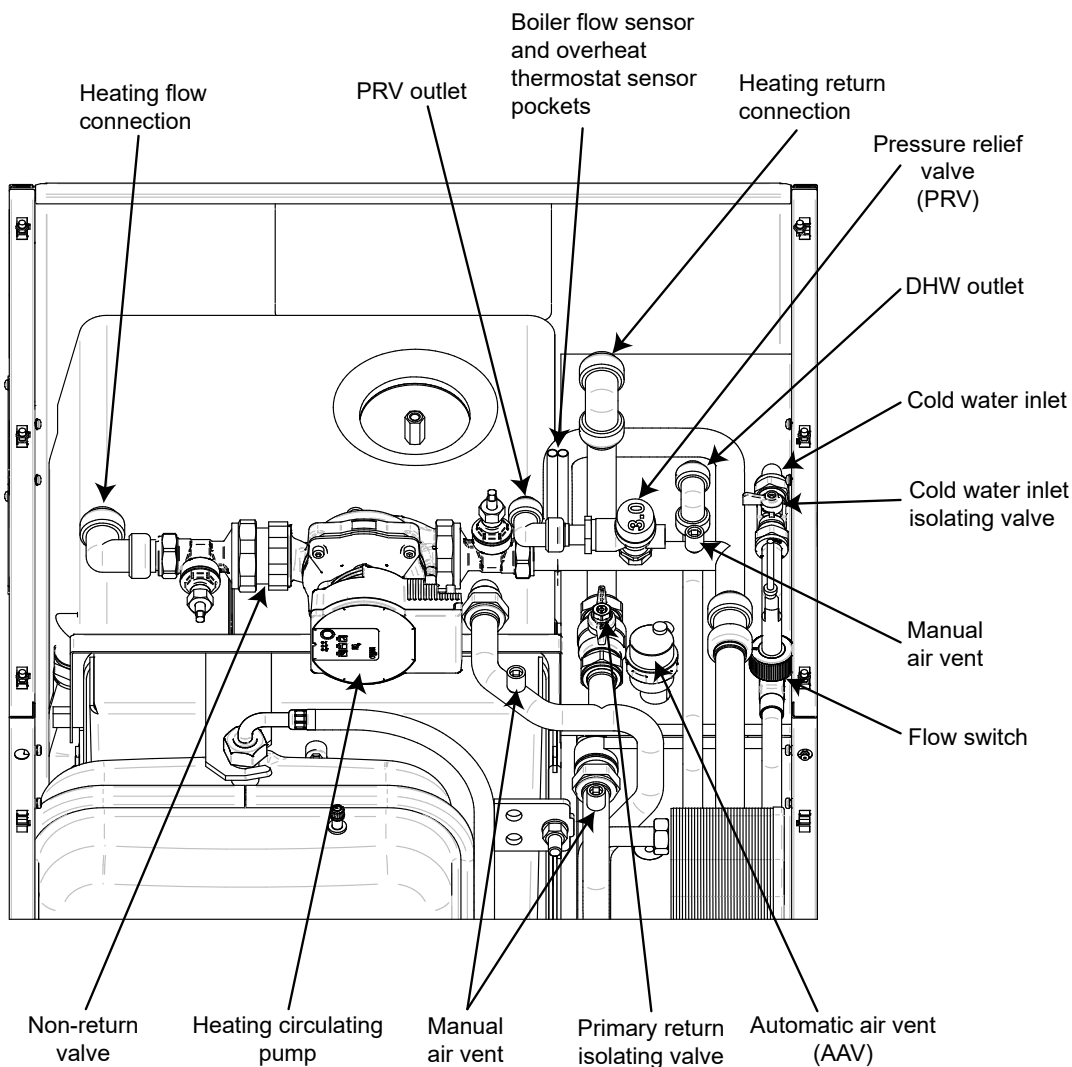

Figure 5-1: VortexBlue Combi pipe positions

5.2 MAKING THE WATER CONNECTIONS

Flow and return pipework can be routed to either side of the boiler, dependant on the flue system used, from the push-fit elbows (supplied) on the flow and return connections. Refer to Figure 5-1 for flow and return pipework positions.

Holes are provided in the rear of the casing side panels to allow the condensate pipe to be run through the back of the boiler. It will be necessary to remove the back panel from the boiler casing to fit this pipework, and to refit the panel before placing the boiler in its final position. Refer to Figure 6-3.

If access will be restricted, make any connections to the boiler before placing it in its final position. If using a balanced flue system - Install the balanced flue system before connecting the heating system pipework to the boiler.

5.3 DOMESTIC HOT WATER SYSTEM

To maintain a longer and more consistent hot water temperature, a flow restrictor is factory fitted to the VortexBlue Combi 21 to limit the flow rate to approximately 12 litres/minute, and to the VortexBlue Combi 26 to limit the flow rate to approximately 15 litres/minute.

The flow restrictor is located in the outlet side of the cold water inlet isolating valve.

A flow restrictor is not fitted to the VortexBlue Combi 36.

The incoming mains water pressure should be between 1 and 8 bar to ensure efficient operation.

! NOTE !

If the pressure is above 8 bar a pressure reducing valve must be fitted.

The boiler may still operate down to a pressure of 1.0 bar but with a reduced flow rate. The minimum flow rate needed for the flow switch to operate is 3 litres/minute.

To ensure economic use, the pipe runs between the boiler and hot taps should be as short as possible and in 15 mm copper pipe or 22 mm for the VortexBlue Combi 36 only. Where possible the pipework should be insulated to reduce heat loss.

All taps and mixing valves used in the domestic hot water system must be suitable for operating at a mains pressure of up to 8 bar.

If required, a shower may be fitted in the domestic hot water system. It is recommended that thermostatically controlled shower valves are used to protect against a flow of water at too high a temperature. If a fixed head type shower is used, no anti-siphonage devices are required. If a loose or flexible head type shower is used, it must be arranged so that the head cannot fall closer than 25 mm above the top of the bath, thereby preventing immersion in the bath water. If this is not practicable, an anti-siphonage device must be fitted at the point of the flexible hose connection.

The supply of hot and cold mains water direct to a bidet is allowed (subject to local Water Undertaking requirements) provided that the bidet is of the overrim flushing type. The outlets should be shrouded and unable to have a temporary hand held spray attached. Arrangements for antisiphonage are not necessary.

Before the mains water supply pipe is connected to the boiler, it should be thoroughly flushed out to avoid the danger of dirt or foreign matter entering the boiler.

The mains water connection to the boiler must be the first connection from the mains supply.

5.4 TO USE THE WATER HARDNESS KIT

! NOTE !

A water hardness test kit is supplied with the boiler. Should the total hardness of the water supply exceed 125 ppm, an in-line scale inhibitor should be fitted in the cold water supply to the boiler.

Consult the local Water Undertaking if in doubt.

Do not immerse the test strip in running water and avoid contact.

1. Fill a clean container with a sample of water from the mains cold water supply to the boiler.
2. Immerse the test strip in the water for approximately one second, ensuring that all the test zones are fully wetted.
3. Shake off the surplus water and wait for one minute.
4. Assess the colouration of the test zones using the following chart.

Table 5-1: Key to water hardness

Green areas	Violet areas	Hardness	Total hardness mg/l (ppm)
4	0	Very soft	<50 mg/l calcium carbonate
3	1	Soft	<70 mg/l calcium carbonate
2	2	Medium	<125 mg/l calcium carbonate
1	3	Hard	<250 mg/l calcium carbonate
0	4	Very hard	<370 mg/l calcium carbonate

Note: 1mg/l = 1 ppm (part per million)

If the hardness reading is found to be in the medium to very hard range (the shaded area), it is essential that some form of water conditioner or softener is fitted to reduce scale formation within the combination boiler. Failure to do so may invalidate both the manufacturers guarantee and any extended guarantee covering the appliance.

The water conditioner or softener should be fitted to the cold water supply serving the appliance and in accordance with the manufacturer's instructions. Grant UK cannot be held responsible for any damage or misuse caused by the fitting of any water conditioning device.

! CAUTION !

Please protect the domestic hot water system from harmful effects of scale. Problems caused by the build-up of limescale are not covered under the terms of the guarantee.

6 CONDENSATE DISPOSAL

6.1 GENERAL REQUIREMENTS

When in condensing mode the Grant Vortex boilers produce condensate from the water vapour in the flue gases.

This condensate is moderately acidic with a pH value of around 3.27 (similar to orange juice).

Provision must be made for the safe and effective disposal of this condensate.

Condensate can be disposed of using one of the following methods of connection:

Internal connection (preferred option)

- into an internal domestic waste system (from kitchen sink, washing machine, etc.)
- directly into the soil stack

External connection

- into an external soil stack
- into an external drain or gully
- into a rainwater hopper (that is part of a combined system where sewer carries both rainwater and foul water)
- purpose made soakaway

All condensate disposal pipes **must** be fitted with a trap - whether they are connected internally or externally to a domestic waste system/soil stack or run externally to a gully, hopper or soakaway.

6.2 CONNECTIONS

Connections into a rainwater hopper, external drain or gully should be terminated inside the hopper/drain/gully below the grid level but above the water level.

! CAUTION !

Condensate disposal pipes must not be connected directly into rainwater downpipes or to waste/soil systems connected to septic tanks.

Condensate should not be discharged into 'grey water' systems that re-use water used in the home (not including water from toilets).

It should be noted that connection of a condensate pipe to the drain may be subject to local Building Control requirements.

6.3 PIPEWORK

Condensate disposal pipework must be plastic (plastic waste or overflow pipe is suitable).

! NOTE !

Copper or steel pipe is NOT suitable and MUST NOT be used.

Condensate disposal pipes should have a minimum 'nominal' diameter of 22 mm (¾") - e.g. use 21.5 mm OD polypropylene overflow pipe.

Condensate disposal pipes must be fitted with a fall (away from the boiler) of at least 2.5° (~45 mm fall per metre run).

! NOTE !

Where it is not possible for the pipe to fall towards the point of discharge - either internally into a waste system or externally to a gully (e.g. for boilers installed in a basement), it will be necessary to use a condensate pump.

Condensate disposal pipes should be kept as short as possible and the number of bends kept to a minimum.

Pipes should be adequately fixed to prevent sagging, i.e. at no more than 0.5 metre intervals.

6.4 EXTERNAL PIPEWORK

Ideally, external pipework, or pipework in unheated areas, should be avoided. If unavoidable, external pipework should be kept as short as possible (less than 3 metres) and 32 mm waste pipe used to minimise the risk of ice blocking the pipe in freezing conditions.

The number of bends, fittings and joints on external pipes should be kept to a minimum to reduce the risk of trapping condensate.

! NOTE !

For boilers installed in an unheated area such as a loft, basement, outhouse or garage, all condensate pipework should be as 'external'.

The pipework should be insulated using suitable waterproof and weather resistant insulation.

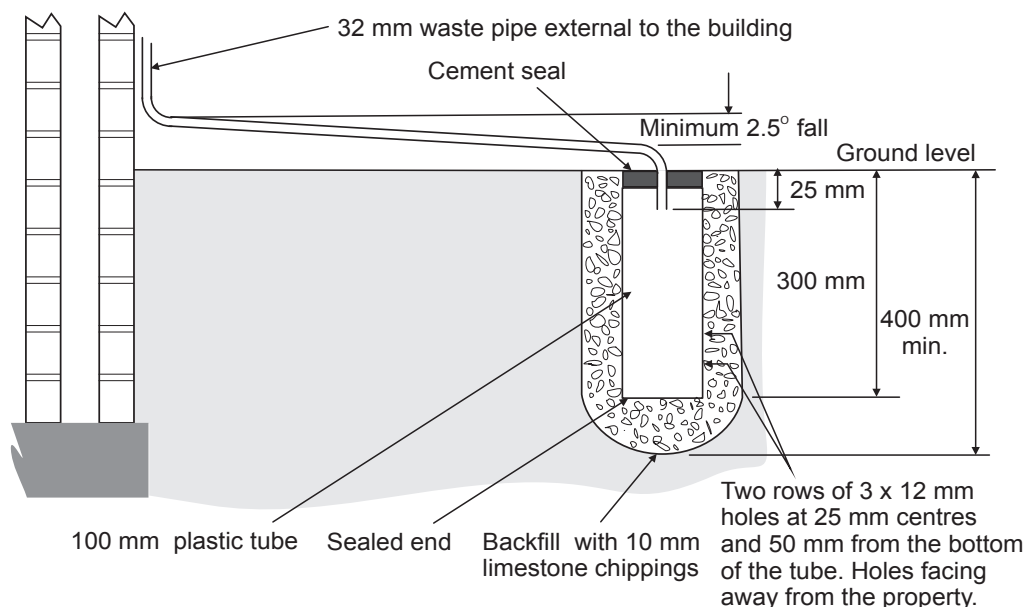

Figure 6-1: Purpose made condensate soakaway

6.5 CONDENSATE SOAKAWAY

To keep external pipework to a minimum, locate the soakaway as close as possible to the boiler but ensure it is at least 500 mm from building foundations and away from other services, e.g. gas, electricity, etc.

The condensate pipe may be run above or below ground level and can enter either the top or side of the soakaway tube. Refer to Figure 6-1.

Ensure that the drainage holes in the soakaway tube face away from the building.

Backfill both the soakaway tube, and the hole around it, with 10 mm limestone chippings.

Only use a soakaway where the soil is porous and drains easily. Do not use in clay soils or where the soil is poorly drained.

! CAUTION !

Any damage due to condensate backing up into the boiler due to a high water table, in the case of a soakaway, or flooded drains when the condensate disposal is via a gully or soil stack, is not covered by the Grant product guarantee.

6.6 CONDENSATE TRAP

Grant Vortex boilers are supplied with a condensate trap to provide the required 75 mm water seal in the condensate discharge pipe from the boiler.

The condensate trap is factory fitted inside the boiler casing - mounted on the inside of the left hand side panel - in an accessible position to allow for routine maintenance.

! NOTE !

If required, this condensate trap may be re-located outside the boiler casing. Refer to the procedure given in Section 6.9. This procedure must be carried out before the boiler is installed.

This trap incorporates a float (which will create a seal when the trap is empty) and an overflow warning outlet (fitted with a plastic sealing cap), see Figure 6-2.

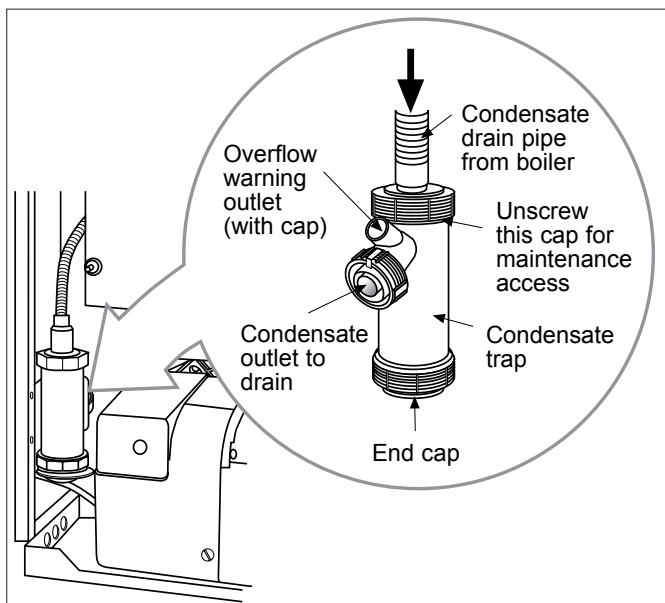

Figure 6-2: Condensate trap

A flexible hose connects the outlet of the condensing heat exchanger to the trap inlet. Ensure the elbow connector on the hose is fully pushed onto the 'top hat' inlet connector of the trap.

With the trap fitted inside the boiler casing, the sealing cap must be fitted. If the trap is re-located outside the boiler then the following applies:

- If connecting the condensate discharge - either internally or externally - into a waste system or soil stack - the sealing cap must be fitted in the trap outlet.
- On external discharge systems to a hopper, gully or soakaway, the sealing cap should be removed from the trap outlet.
- If there is any discharge of condensate from the overflow outlet, this could indicate a blockage (possibly due to freezing). Turn off the boiler and investigate the cause. If necessary contact your service engineer for assistance.

! WARNING !

Care should be taken when siting the trap such that the overflow outlet is readily visible and that any condensate overflowing from the outlet cannot cause either a hazard to persons or damage to surrounding property or equipment.

6.7 CONDENSATE DISPOSAL PIPEWORK

The condensate trap outlet is at an angle of 48° below the horizontal. This is to automatically give a 3° fall on any 'horizontal' runs of condensate disposal pipe. Refer to Figure 6-2 and see trap outlet/pipe.

The outlet of the trap will accept 21.5 mm to 23 mm OD Polypropylene overflow pipe for the condensate discharge pipe.

This discharge pipe can exit through the left side of the boiler through one of two pre-cut 'knock-outs' in the lower part of the left casing panel. Push out the 'knock-out' from the required hole taking care not to distort the side panel.

! NOTE !

When connecting plastic discharge pipe, ensure that the pipe is fully pushed into the outlet end on the flexible hose to prevent the possibility of leakage.

6.8 INSPECTION AND CLEANING OF TRAP

The trap **must** be checked at regular intervals (e.g. on every annual service) and cleaned as necessary to ensure that it is clear and able to operate.

The bottom bowl can be unscrewed from the trap body for inspection and cleaning.

To inspect and clean the trap:

1. Disconnect flexible condensate hose from inlet connector.
2. Unscrew the inlet connection nut.
3. Remove the inlet connector and nut from trap.
4. Disconnect the condensate disposal pipe from the trap outlet.
5. Remove trap from bracket.
6. Remove float from trap - clean if necessary.
7. Inspect inside of trap and clean as necessary.
8. Check the condition of the flexible condensate hose between the trap and the boiler.
9. Re-assemble trap, re-fit to boiler and re-connect flexible hose. Ensure that hose is fully pushed onto the trap inlet connector.

! CAUTION !

Failure to regularly check and clean the condensate trap may result in damage to the boiler and will not be covered by the product guarantee.

6.9 EXTERNAL CONDENSATE TRAP FITTING

! NOTE !

This procedure must be carried out before the boiler is installed.

To re-locate the factory-fitted trap outside the boiler casing, use the following procedure:

1. Remove both the top casing panel(s) from the boiler.
2. Unscrew and remove the screws securing the bottom of the rear panel to the base tray of the boiler casing.
3. Grip the top of the rear panel and pull it upwards. Slide it all the way up and out of the channels on the rear edge of the two casing side panels to remove it from the boiler. Refer to Figure 6-3.
4. Push out pre-cut 'knock-out' from condensate outlet hole in rear of left side casing panel.
5. Disconnect condensate discharge hose from heat exchanger and condensate trap and remove it from the boiler.
6. Replace with condensate trap hose (Grant product code: VBS107).
7. Pass the straight connector end of the hose through the new hole in the left hand casing panel. Push the straight connector firmly onto the condensate outlet connection of the condensing heat exchanger as far as possible.
8. Refit the rear casing panel. Ensure that both edges of the rear panel are correctly located into the channels in the rear edge of both side casing panels. Then carefully slide the rear panel fully down until the top edges is level with the top edges of the side panels.
9. Secure the bottom of the rear panel to the base tray with the screws previously removed.
10. Remove the trap from the mounting bracket.
11. Unscrew and remove the trap mounting bracket from the left side panel.
12. Fix the trap mounting bracket to the wall adjacent to the boiler in the required position.

! NOTE !

The top of the trap must be below the condensate connection on the boiler.

13. Re-fit the trap to the mounting bracket. The mounting bracket supplied with the trap must be used - the trap should not be supported by the condensate pipework only.
14. Connect the flexible condensate hose to the trap - pushing the right angle hose connector onto the trap inlet connection.

! NOTE !

The flexible hose must fall continuously from the outlet to the top of the trap.

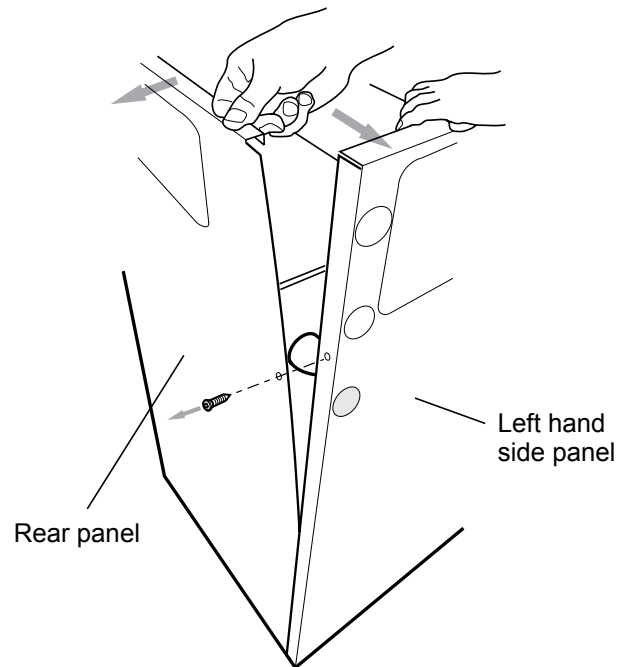

Figure 6-3: Gaining access to the condensate outlet

7 SEALED SYSTEMS

7.1 SEALED SYSTEM REQUIREMENTS

All Grant VortexBlue Combi boilers must be used as part of a sealed system complying with the requirements of BS EN 12828, BS EN 12831 and BS EN 14336.

The maximum temperature of the central heating water is 75°C.

The boiler is supplied factory fitted with the following items:

- 24 litre diaphragm expansion vessel complying with BS EN 13831*
- Pressure gauge
- Pressure relief (safety) valve
- Approved filling loop

7.1.1 EXPANSION VESSEL

On all VortexBlue Combi models the expansion vessel is factory fitted on the front of the boiler, inside the casing.

It is connected to the boiler via a flexible hose to allow the vessel to be removed from the boiler to access the boiler to access the front cleaning door without disconnecting it. Take care to ensure that the flexible hose is not twisted or kinked.

! NOTE !

Ensure that the expansion vessel is of sufficient size for the system volume.

Refer to BS 7074-1 or the Domestic Heating Design Guide to check the vessel size required.

7.1.2 PRESSURE GAUGE

The pressure gauge is factory fitted in the boiler control panel. It has an operating range of 0 to 4 bar. Refer to Section 1.4.

7.1.3 PRESSURE RELIEF (SAFETY) VALVE

The pressure relief (safety) valve is factory fitted to the flow pipework on the top of the boiler.

A discharge pipe should be connected to the outlet of the pressure relief (safety) valve. This discharge pipe must terminate in a position that will allow the discharge to be seen, but cannot cause injury to persons or damage to property. Refer to Section 5.1 for further details.

7.1.4 FILLING LOOP

In order to fill or top up the heating system, a factory fitted filling loop is located at the front of the boiler, to the right of the expansion vessel.

Refer to Section 7.2 for details on how to fill and vent the system.

7.1.5 HEATING SYSTEM

The maximum 'setpoint' temperature for the central heating water is 75°C. Refer to Section 1.1.

An air vent should be fitted in the flow and return pipes of the highest point of the system.

If thermostatic radiator valves are fitted to all radiators, a system by-pass must be fitted. The by-pass must be an automatic type.

All fittings used in the system must be able to withstand pressures up to 3 bar. Radiator valves must comply with the requirements of BS 2767.

One or more drain taps (to BS 2879) must be used to allow the system to be completely drained.

If thermostatic radiator valves are fitted, the system must incorporate an adequate by-pass.

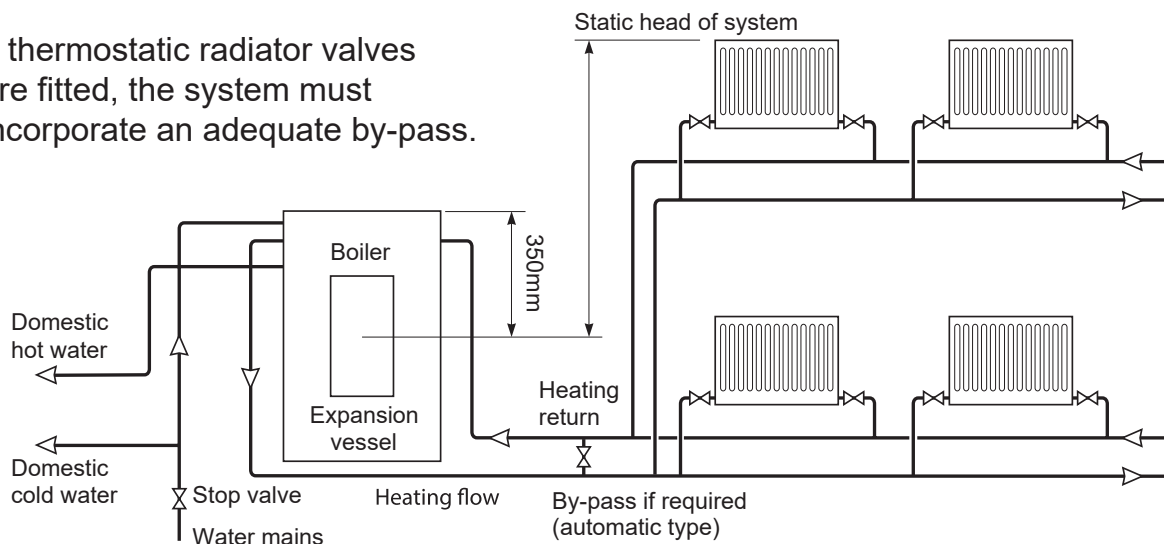

Figure 7-1: Sealed system

7.2 FILLING THE SEALED SYSTEM

Filling of the system must be carried out in a manner approved by the local Water Undertaking.

The procedure for filling the sealed system is as follows:

1. BEFORE filling the system, set the air charge pressure in the expansion vessel to 1.3 bar, i.e. 0.2 bar below the cold system fill pressure of 1.5 bar.

! NOTE !

The air charge pressure may be checked using a tyre pressure gauge on the expansion vessel Schraeder valve. The vessel may be re-pressurised, when necessary, using a suitable pump. When checking the air charge pressure, the water in the heating system must be cold and the system pressure reduced to zero.

2. Check that the cap on the automatic air vent on the primary store is open one turn. Refer to Figure 5-1.
3. Ensure that the flexible filling loop is connected between the double check valve (on the cold water pipe) and the filling point on the drain cock connection in the lower right corner of the boiler.
Also ensure that the shut off valves on both the double check valve and the fill point are closed.
Note that these valves are open when the operating lever is in line with the valve, and closed when it is at right angles to it.
4. Open the shut off valve on the fill point valve.
5. Gradually open the shut off valve on the double check valve until water is heard to flow into the system from the cold water supply.
6. When the needle of the pressure gauge is between 0.5 and 1.0 bar, close the shut off valve on the double check valve.
7. Vent each radiator in turn, starting with the lowest one in the system, to remove air.
8. Open each of the manual air vents in turn to vent the boiler and boiler pipework. See Figure 5-1.
9. Vent the pump. Refer to Section 7.3 and Appendix A2.
10. Continue to fill the system until the pressure is 1.5 bar. Close the fill point valve.
The system fill pressure (cold) should be 0.2 - 0.3 bar greater than the vessel air charge pressure.
Refer to the Domestic Heating Design Guide for further information if required.
11. Repeat steps 7 to 9 as required until system is full of water at 1.5 bar and vented.
12. Water may be released from the system by manually operating the safety valve until the system design pressure is obtained.
13. Close the shut off valves on the fill point and double check valves and disconnect the filling loop.
14. Leave the cap open one turn on the automatic air vent on the primary store.
15. Check the system for water soundness, rectifying where necessary.
16. Set the heating switch on the boiler control panel to OFF. Set the hot water switch to constant and switch the boiler ON. Refer to Figure 1-2 for control panel details.
17. Allow the boiler to run until the primary store is heated and the burner switches off.
18. Note the system pressure using the red marker on the pressure gauge. Then vent the boiler by using the manual air vents on the boiler pipework in turn.
19. Re-check the system pressure and top up to get back to the pressure noted in step 18 above.

7.3 VENTING THE PUMP

For those heating circulating pumps fitted with a vent plug, it is important that the pump is properly vented to avoid an air lock and also prevent it running dry and damaging the bearings.

Unscrew and remove the plug from the centre of the pump motor. Using a suitable screwdriver, rotate the pump spindle about one turn. Replace the plug in the motor. Do not over tighten.

! NOTE !

Some heating circulating pumps are not fitted with a vent plug so it is not possible to vent these pumps in the manner described above. Refer to pump manufacturers own instructions for further details.

If a Wilo Para pump is used, please refer to Appendix A3 at the back of this installation and servicing manual for guidance on venting the pump.

7.4 PRESSURE RELIEF (SAFETY) VALVE OPERATION

Check the operation of the pressure relief (safety) valve as follows:

1. Turning the head of the valve anticlockwise until it clicks. The click is the safety valve head lifting off its seat allowing water to escape from the system.
2. Check that the water is escaping from the system.
3. Top-up the system pressure, as necessary, by following the procedure outlined in Section 7.2.

! NOTE !

For information on the circulating pump fitted to all VortexBlue combi models, please refer to Appendix A2 or A3 as required at the back of this installation and servicing manual.

8 ELECTRICAL

! WARNING !

Ensure that the electrical supply has been isolated before making any connections to the boiler.

8.1 GENERAL

The VortexBlue Internal Combi requires a permanent ~230 V 1ph 50Hz supply. It must be protected by a 5 Amp fuse.

Refer to Figure 8-1 for the control panel wiring diagram for all VortexBlue Internal combi models.

Refer to Figures 8-2, 8-3 and 8-4 for wiring diagrams showing how to connect the control system.

! WARNING !

The Vortex Boiler contains electrical switching equipment and must be earthed.

The supply must be fused at 5 Amp and there must only be one common isolator for the boiler and control system, providing complete electrical isolation.

A fused double pole switch or a fused three pin plug and shuttered outlet socket should be used for the connection.

The power supply cable should be at least 0.75 mm² PVC as specified in BS 6500, Table 16.

All the wiring and supplementary earth bonding external to the boiler must be in accordance with the current IET Wiring Regulations.

Any room thermostat or frost thermostat used must be suitable for use on mains voltage.

In the event of an electrical fault after installation of the boiler, the following electrical system checks must be carried out:

- Short circuit
- Polarity
- Earth continuity
- Resistance to earth

! NOTE !

If the supply cord is damaged, it must be replaced by the manufacturer, its service agent or similarly qualified persons in order to avoid a hazard.

8.2 CONNECTING THE POWER SUPPLY

A three core cable is required to connect the boiler terminal block to the live supply. Refer to Figure 8-1 for boiler wiring terminal details.

! NOTE !

Ensure that the route and length of the supply cable is such that the boiler front cover plate can be easily removed without disconnecting the supply cable from the terminal block.

The procedure for connecting the boiler power supply is as follows:

1. Lift off the boiler top front casing panel, if it has not already been removed.
2. Loosen (do not remove) the four screws securing the control panel to the side panels, hinge the panel forward and allow it to drop down to gain access to the top of the panel.
3. Remove the two screws securing the terminal block cover and lift off the cover.
4. Remove the screws securing the cable clamp and open clamp. Route the supply cable through the cable clamp.
5. Connect the power supply cable to the left hand terminal block as follows:
 - Brown to mains live (terminal 3)
 - Blue to mains neutral (terminal 2)
 - Green/Yellow to mains earth (terminal 1)
6. Make the remaining required connections to the control panel, as detailed in this section.
7. Secure the cable clamp.
8. Re-fit terminal block cover on control box and fasten with the two screws previously removed.
9. Close the hinged panel and tighten the four screws securing the control panel to the side panels.
10. Replace top casing panels.
11. Ensure that all external wiring is adequately supported.

! WARNING !

After completing electrical connections and before reconnecting the electrical supply to the boiler, replace the terminal block cover and secure it using the screws provided.

12. Re-connect the electrical supply and check operation of heating system controls (programmer, room thermostats, etc.).
13. Refer to Instructions provided with the programmer for operation and setting.
14. Leave the Programmer and Thermostat Instructions with the user after installation for their future reference.

BURNER LEAD PLUG/SOCKET CONNECTOR

On all models, the electrical cable between the boiler control panel and burner is now fitted with an in-line 4-way plug and socket connector. This enables the burner to be easily disconnected from the boiler control panel for ease of removal for servicing.

8.3 CONNECTING THE CONTROLS - HEATING ONLY

To control the central heating on / off periods only (and not the domestic hot water), it is recommended to use one of the following options:

- A remote single channel timer and room thermostat.
- A 'plug-in' Grant Mechanical 24-hour timer (product code: MTKIT) and room thermostat.
- A programmable room thermostat.

With any of these options the timer, room thermostat or programmable room thermostat should be sited at a suitable and convenient location within the property.

CONNECTION OF AN EXTERNAL REMOTE TIMER AND ROOM THERMOSTAT

! WARNING !

Any remote timer must be of a single channel 230V type with voltage free output contacts. Refer to Figure 8-2 for connection details.

1. Lift off the boiler case top panel, if it has not already been removed.
2. Loosen (do not remove) the four screws securing the control panel to the side panels, hinge the panel forward and allow it to drop down to gain access to the top of the panel.
3. Remove the two screws securing the terminal block cover and lift off the cover.
4. Remove the screws securing the cable clamp and open clamp.
5. Pass a 3-core cable (or 3-core and earth if the room thermostat to be used has an earth connection) through the cable clamp on the control panel.
6. Remove the Orange room thermostat link wire from terminals 25 & 26 on the connection block and connect the wires from the room thermostat. Refer to Figure 8-2 for further details.
7. Connect the room thermostat to the terminal block in accordance with the room thermostat manufacturer's instructions.
8. Pass a 4-core cable (or 4-core and earth if the timer to be used has an earth connection) through the cable clamp on the control panel.
9. Connect the two switch wires from the timer to terminals 19 & 20 on the connection block, using Figure 8-2 for guidance.
10. Connect the live, neutral (and earth if required) from the timer to terminals 3, 2 & 1 respectively on the boiler terminal block. Refer to Figure 8-2 for further details.
11. Make the remaining required connections to the control panel, as detailed in this section.
12. Secure the cable clamp.
13. Re-fit terminal block cover on control box and fasten with the two screws previously removed.
14. Close the hinged panel and tighten the four screws securing the control panel to the side panels.
15. Replace top casing panels.
16. Re-connect electrical supply and check operation of the timer and room thermostat.
17. Refer to the Fitting and User Instructions supplied with the timer for operating and setting.
Leave the Timer and Room Thermostat Fitting and User instructions with the user after installation.

FITTING AND CONNECTION OF A GRANT 'PLUG-IN' 24-HOUR TIMER (MTKIT) AND ROOM THERMOSTAT

1. Pass a 3-core cable (or 3-core and earth if the room thermostat to be used has an earth connection) through the cable clamp on the control panel.
2. Remove the Orange room thermostat link wire from terminals 25 & 26 on the connection block and connect the wires from the room thermostat. Refer to Figure 8-3 for further details.
3. Connect the room thermostat to the terminal block in accordance with the room thermostat manufacturer's instructions.

Fit and connect the 'plug-in' timer as follows:

1. Remove front and top boiler casing panels. Loosen (do not remove) the four screws securing control panel to the side panels. Hinge the panel forward to access top and rear of control panel.
2. Remove the two screws and lift off the terminal block cover from top of control panel.
3. Remove the four screws from the rear of the control panel and remove the rear access cover.
4. Carefully push through and remove square pre-cut 'knockout' section in the control panel front.
5. Feed the wires through hole in control panel front and then up through rectangular opening in control panel top. Connect wires to terminals 19 & 20 on the control panel, using Figure 8-3 for guidance.
6. Carefully fit the timer into the square hole in the control panel.
7. Using a flat-bladed screwdriver first push and then turn clockwise the plastic lugs at the top R.H. and the bottom L.H. corners of the timer, to secure the timer to the fascia.
8. Re-fit the rear access cover to the control panel and secure with the four screws previously removed.
9. Make the remaining required connections to the control panel, as detailed in this section.
10. Secure the cable clamp.
11. Re-fit terminal block cover on control box and fasten with the two screws previously removed.
12. Close the hinged panel and tighten the four screws securing the control panel to the side panels.
13. Replace front and top casing panels.
14. Reconnect electrical supply and check the operation of the timer. Refer to Fitting and User Instructions supplied with the timer for setting.

8.4 CONNECTING THE CONTROLS - HEATING AND HOT WATER

If control of both the heating and hot water operation of the boiler is required, it is recommended to use a two channel programmer and room thermostat.

! NOTE !

If a two-channel programmer is used with the VortexBlue Internal Combi, the user must be made aware that if the hot water channel is left in the OFF position, hot water may not be available on demand, and that the primary store may need to recover before any hot water is available.

CONNECTION OF EXTERNAL REMOTE PROGRAMMER AND ROOM THERMOSTAT

! NOTE !

The remote two-channel programmer must be suitable for 230V and internally linked. Refer to Figure 8-4 for connection details.

1. Lift off the boiler case top panel, if it has not already been removed.
2. Loosen (do not remove) the four screws securing the control panel to the side panels, hinge the panel forward and allow it to drop down to gain access to the top of the panel.
3. Remove the two screws securing the terminal block cover and lift off the cover.
4. Remove the screws securing the cable clamp and open clamp.
5. Pass a 3-core cable (or 3-core and earth if the room thermostat to be used has an earth connection) through the cable clamp on the control panel.
6. Remove the Orange room thermostat link wire from terminals 25 & 26 on the connection block and connect the wires from the room thermostat. Refer to Figure 8-4 for further details
7. Connect the room thermostat to the terminal block in accordance with the room thermostat manufacturer's instructions.
8. Pass a 4-core cable (or 4-core and earth if the remote programmer to be used has an earth connection) through the cable clamp on the control panel.
9. Connect the two switch wires from the programmer as shown in Figure 8-4.
10. Connect the live, neutral (and earth if required) from the timer to terminals 3, 2 & 1 respectively on the boiler terminal block. Refer to Figure 8-4 for further details.
11. Make the remaining required connections to the control panel, as detailed in this section.
12. Secure the cable clamp.
13. Re-fit terminal block cover on control box and fasten with the two screws previously removed.
14. Close the hinged panel and tighten the four screws securing the control panel to the side panels.
15. Replace top casing panels.
16. Re-connect electrical supply and check operation of the timer and room thermostat.
17. Refer to the Fitting and User Instructions supplied with the timer for operating and setting.

Leave the Timer and Room Thermostat Fitting and User instructions with the user after installation.

8.5 CONNECTING AN EXTERNAL FROST THERMOSTAT

The boiler is fitted with two forms of pre-set internal frost protection, as follows:

Water temperature:

Should the central heating water temperature (detected by the flow thermistor) fall to below 8°C this frost protection function will be activated and will operate as follows to protect the boiler from freezing:

- The heating circulating pump will run for a period of 15 minutes. If during this time the water temperature exceeds 15°C the pump will stop.
- If after the 15 minutes the temperature is less than 10°C the burner will fire and continue to do so until the flow thermistor detects a temperature of 30°C when the burner will stop. The heating circulating pump will then run for a period of 2 minutes before also stopping.

Air temperature:

Should the air temperature around the boiler fall to below 5°C this frost protection will be activated and will operate as follows to protect the boiler from freezing:

- First the heating circulation pump will operate for a period of 15 minutes. If after that time the air temperature sensed exceeds 10°C the pump will stop.
- If after the 15 minutes the temperature is less than 10°C the burner will fire and continue to do so until the flow thermistor detects a temperature of 30°C when the burner will stop. The heating circulating pump will then run for a period of 2 minutes before also stopping.

For additional protection of either the entire heating system, or any exposed parts of the heating system (e.g. if the boiler is installed in an external boiler house, un-heated garage or attic) a remote frost thermostat can be connected to the boiler. This will operate in conjunction with the internal frost protection and, when activated, the boiler will operate as described at the start of Section 8.5.

This remote frost thermostat should be sited within the house in such a place that any rise or fall in ambient air temperature can be detected, i.e. in a room with a radiator.

To connect a remote frost thermostat (for example, a Danfoss Randall RET230F), proceed as follows:

1. Lift off the boiler case top panel, if it has not already been removed.
2. Loosen (do not remove) the four screws securing the control panel to the side panels, hinge the panel forward and allow it to drop down to gain access to the top of the panel.
3. Remove the two screws securing the terminal block cover and lift off the cover.
4. Remove the screws securing the cable clamp and open clamp.
5. Connect the wires from the frost thermostat to terminals on the control panel as follows:
 - Frost thermostat Neutral (N) to terminal 21 on PCB connector.
 - Frost thermostat Live (L) to terminal 24 on PCB connector.
 - Frost thermostat Switched Live-ON (3) to terminal 23 on PCB connector.
6. Refer to Figures 8-2 to 8-4 for typical connection of Remote Frost Thermostat.
7. If an alternative Frost thermostat to the Danfoss Randall RET230F is used, connect it in accordance with the frost thermostat manufacturer's instructions.
8. Make the remaining required connections to the control panel, as detailed in this section.
9. Secure the cable clamp.
10. Re-fit terminal block cover on control box and fasten with the two screws previously removed.
11. Close the hinged panel and tighten the four screws securing the control panel to the side panels.
12. Replace top casing panels.

! NOTE !

This external frost thermostat will operate in parallel with the internal frost thermostat.

! NOTE !

For total system protection against freezing, particularly during extended periods without electrical power, Grant recommend the use of a combined heating system antifreeze and corrosion inhibitor, used in accordance with the manufacturer's instructions.

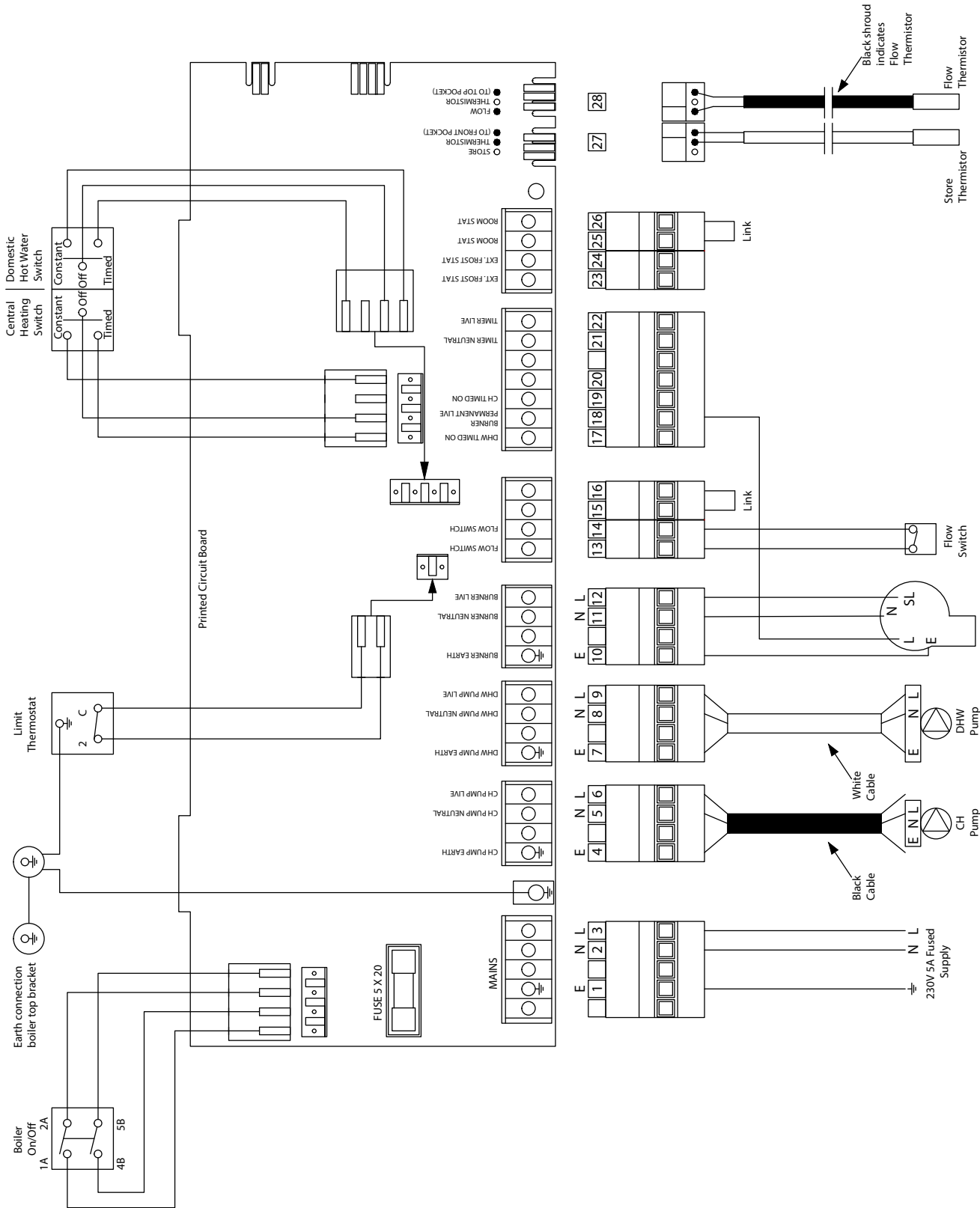

Figure 8-1: VortexBlue internal Combi control panel wiring diagram

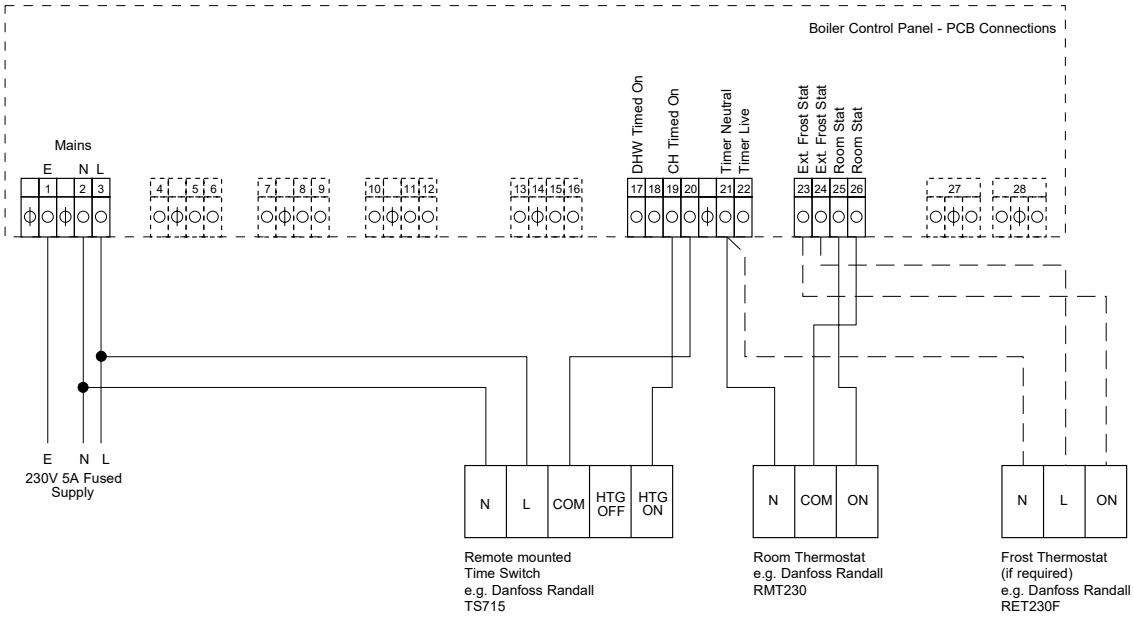

Figure 8-2: Connections for a remote timer and room thermostat

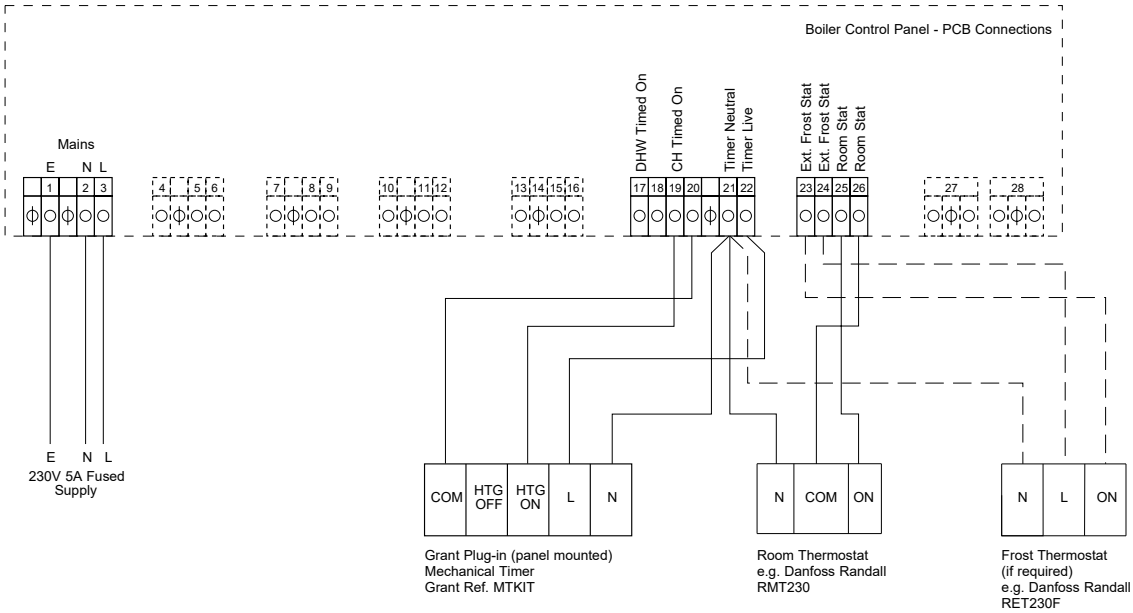

Figure 8-3: Connections for an MTKIT and room thermostat

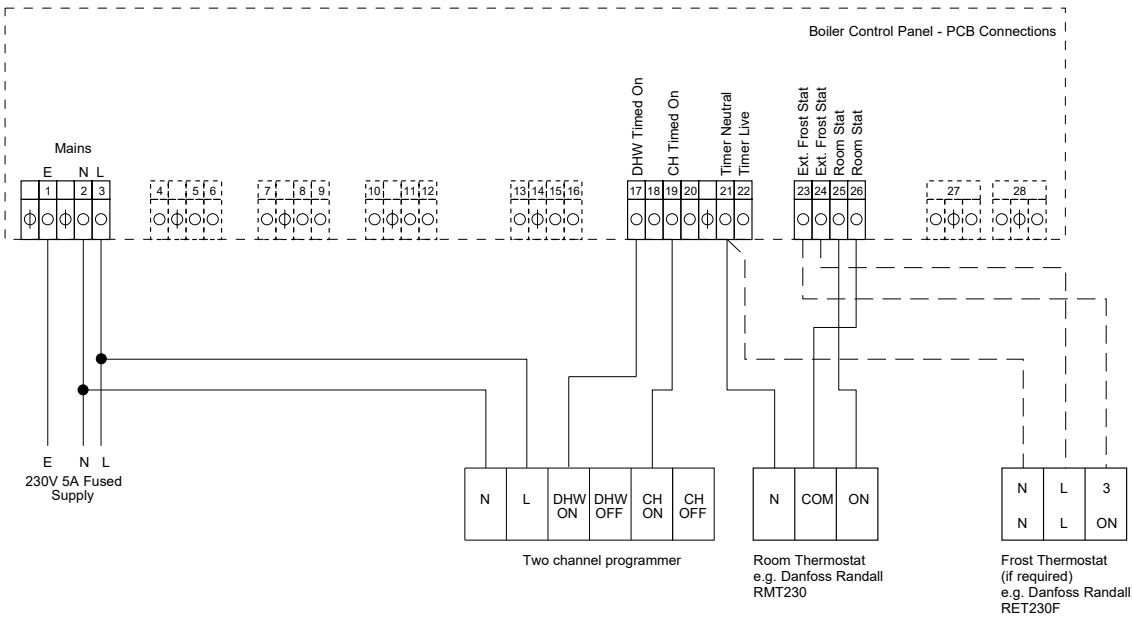

Figure 8-4: Connections for remote two channel programmer and room thermostat

Page intentionally left blank

9 FLUE SYSTEM AND AIR SUPPLY

9.1 AIR SUPPLY

A sufficient permanent air supply to the boiler should be provided for the following reasons:

- For proper combustion of fuel and effective discharge of combustion products to the open air.
- For the ventilation of any confined space in which the boiler is installed to prevent overheating of the boiler and any equipment in and near the boiler.

It is essential to ensure that any ventilation openings in the property are positioned to avoid accidental blockage and also to minimise discomfort caused to the building occupants by draughts.

Further details may be obtained from BS 5410-1.

! NOTE !

For a boiler fitted in a compartment, which is ventilated as shown, no additional allowance is necessary.

Open flue - Extract fans, where needed, should be in accordance with Section 5.4.7 in BS 5410-1.

All ventilation areas given are for domestic applications and relate to the full output rating of the boiler.

For installations in older dwellings (constructed prior to the introduction of Approved Document L1A 2006) the first 5 kW of output can be ignored. For all other cases refer to BS 5410-2.

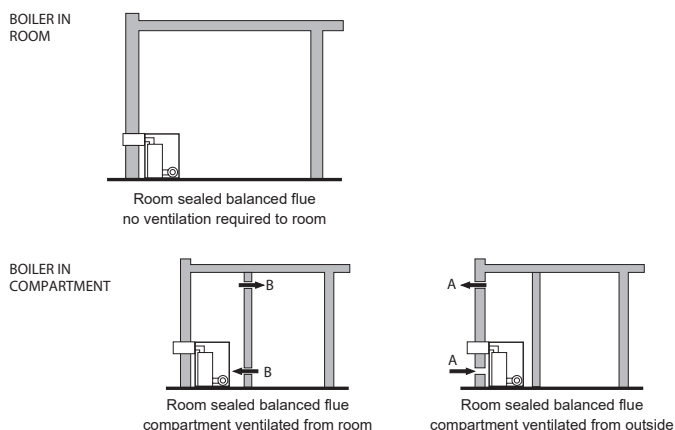

Figure 9-1: Air supply for room sealed balanced flue boilers

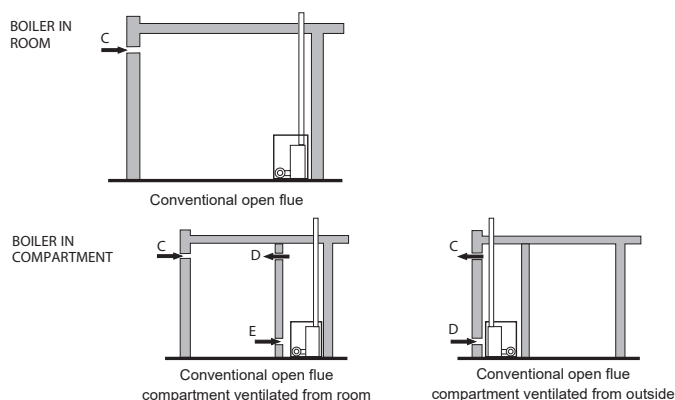

Figure 9-2: Air supply for conventional flue boilers

9.2 CONVENTIONAL FLUE SYSTEMS

! NOTE !

Under no circumstances can Grant Vortex boilers be installed with existing flue systems. Only flue systems and components suitable for wet flues should be used.

Failure to install the correct type of flue system will invalidate the guarantee.

Grant condensing boilers have high operating efficiencies and low flue gas temperatures. Care must be taken to ensure the flue system is suitable for the very low flue gas temperatures and condensate in the flue gases.

Suitable conventional flue systems are available from Grant UK.

The flue must terminate in a down draught free area, i.e. at least 600 mm above the point of exit through the roof or preferably above the ridge level.

The condensate may be allowed to run back into the boiler. A condensate drain at the base of the flue system is not required.

The high level flue terminal must be at least 600 mm from any opening into the building, and 600 mm above any vertical structure or wall less than a horizontal distance of 750 mm from the terminal.

If an existing chimney is to be used, it must be lined with a smooth bore stainless steel liner suitable for use with oil fired condensing boilers. The top and bottom of the annular space must be sealed.

Grant recommends the use of the Grant 'Orange' flue system, specifically designed for the Vortex range of condensing boilers.

The internal flue and liner diameter for all models up to 46 kW output must be 100 mm (4 in).

The maximum vertical height (from the top of the boiler to the terminal) for the 'Orange' system is 19 metres.

Table 9-1: Ventilation areas

Output	21		26		36	
	cm ²	in ²	cm ²	in ²	cm ²	in ²
Vent A	116	18	143	22	198	31
Vent B	232	36	286	44	396	61
Vent C	116	18	143	22	198	31
Vent D	232	36	286	44	396	61
Vent E	348	54	429	69	594	92

! NOTE !

The Grant Orange system flexible stainless steel liner is directional. The arrows marked on the liner MUST be pointing vertically upwards, following the direction of the flue gases. Failure to comply with this instruction could lead to a leakage of condensate from the flue liner.

If a rigid flue is used externally, it must be of the twin-wall type, to reduce the possibility of the condensate freezing in the flue, incorporating seals at all joints, constructed with a stainless steel inner skin and be suitably insulated and weatherproofed. The internal flue diameter for a rigid flue for all Combi models is 100 mm (4 in). Use the larger '200' size of 'Green' system components as listed in Table 9-5.

For a rigid conventional flue system Grant recommends the use of the Grant 'Hybrid' flue system, which uses the Grant Green and Orange flue system components for this application. Refer to Section 1.3 for details.

! NOTE !

As no flue adaptor is supplied with the boiler, in order to correctly connect the hybrid system, it will be necessary to purchase the Grant CF adaptor kit (product code: CFA15/70).

If required, it is possible to use the white painted single-wall straight flue extensions, adjustable extensions and elbows from the Grant 'Orange' system for the internal section of the flue system, see Figure 9-3. These components can be fitted between the boiler connector and flue adaptor. The flue adaptor, to which the external twin-wall 'Green' flue components are connected, can therefore be situated just before the flue system passes through the wall. See Figure 9-4.

! NOTE !

Grant 'Orange' system single-wall flue components must not be used externally.

The maximum vertical height (from the top of the boiler to the terminal) for the 100 mm diameter hybrid 'Green/Orange' system is 19 metres.

Grant 'Green' twin-wall flue is recommended for externally run flues to reduce the possibility of the condensate freezing in the flue.

No part of any flue system should be made of an asbestos material; aluminium must not be used in any part of the flue.

Only stainless steel flue components should be used.

If the draught conditions are satisfactory, the flue should terminate with a standard cowl.

Refer to the locally applicable Building Regulations, BS 5410:1 and OFTEC Installation Requirements (OFTEC Technical Books 2 and 4) for further guidance on conventional flue systems.

! CAUTION !

It is important to ensure that the flue system is sealed and that condensate cannot escape. Up to 1.5 l/h of condensate can be produced in a conventional flue system.

Do not use fire cement. The use of high temperature silicone sealants is recommended.

! NOTE !

To comply with the requirements of the Building Regulations Approved Document J - conventional flue systems must have a flue data plate. A suitable data plate is supplied with the Grant Orange flue system and should be displayed next to the boiler or flue.

FLUE LINING KITS

Grant EZ-Fit Flexi Pack conventional flue system (Orange System)

A range of Flexi pack conventional flue lining kits are available from Grant UK. The packs have been specifically produced for Grant Vortex oil fired condensing boilers.

The pack includes a terminal/top plate/flexi flue adaptor, stainless steel smooth bore flexible flue liner, a rigid to flexi adaptor and a boiler flue connector.

100mm Flue Lining components are suitable for use on all Grant Vortex Internal Combi models.

Table 9-2: Conventional flue kits

Product code	Flexi pack (Orange system)
GFKIT 6/100	100 mm diameter x 6 metre
GFKIT 8/100	100mm diameter x 8 metre
GFKIT 10/100	100mm diameter x 10 metre
GFKIT 11/100	100mm diameter x 11 metre
GFKIT 12/100	100mm diameter x 12 metre
GFKIT 14/100	100mm diameter x 14 metre
GFKIT 16/100	100mm diameter x 16 metre

Extensions

A range of white powder coated single wall extensions are available to connect the boiler to the flexible liner.

The nominal diameter of the extensions is 100 mm.

Extensions are supplied with locking bands.

Table 9-3: Extensions

Product code	Extensions (Orange system)
WX 150/100	100 mm diameter x 150 mm
WX 250/100	100 mm diameter x 250 mm
WX 450/100	100 mm diameter x 450 mm
WX 950/100	100 mm diameter x 950 mm
WXA 250/100	100 mm diameter adjustable extension (235 to 300 mm)
WE 45/100	100 mm diameter 45° elbow

! NOTE !

The rigid flue between the boiler and flexible flue liner should incorporate an adjustable section to allow inspection and cleaning of the flue system.

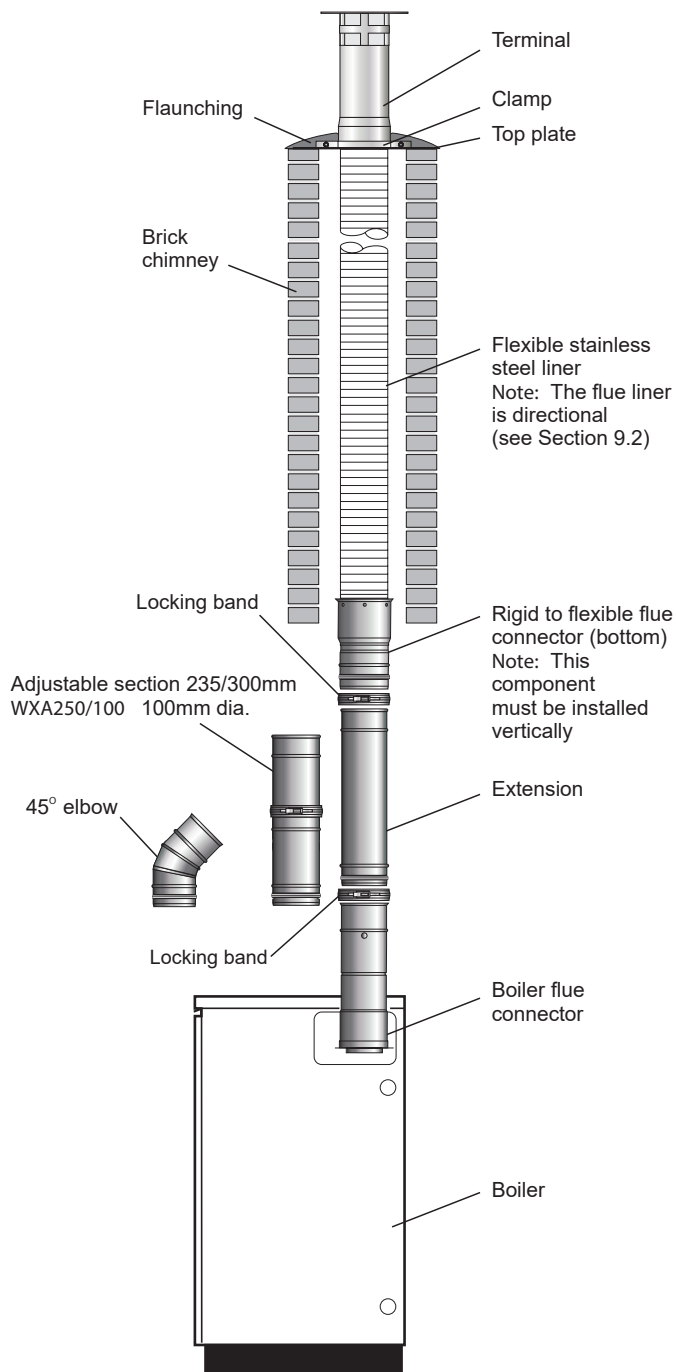

Figure 9-3: Grant Orange flue system in a typical brick chimney

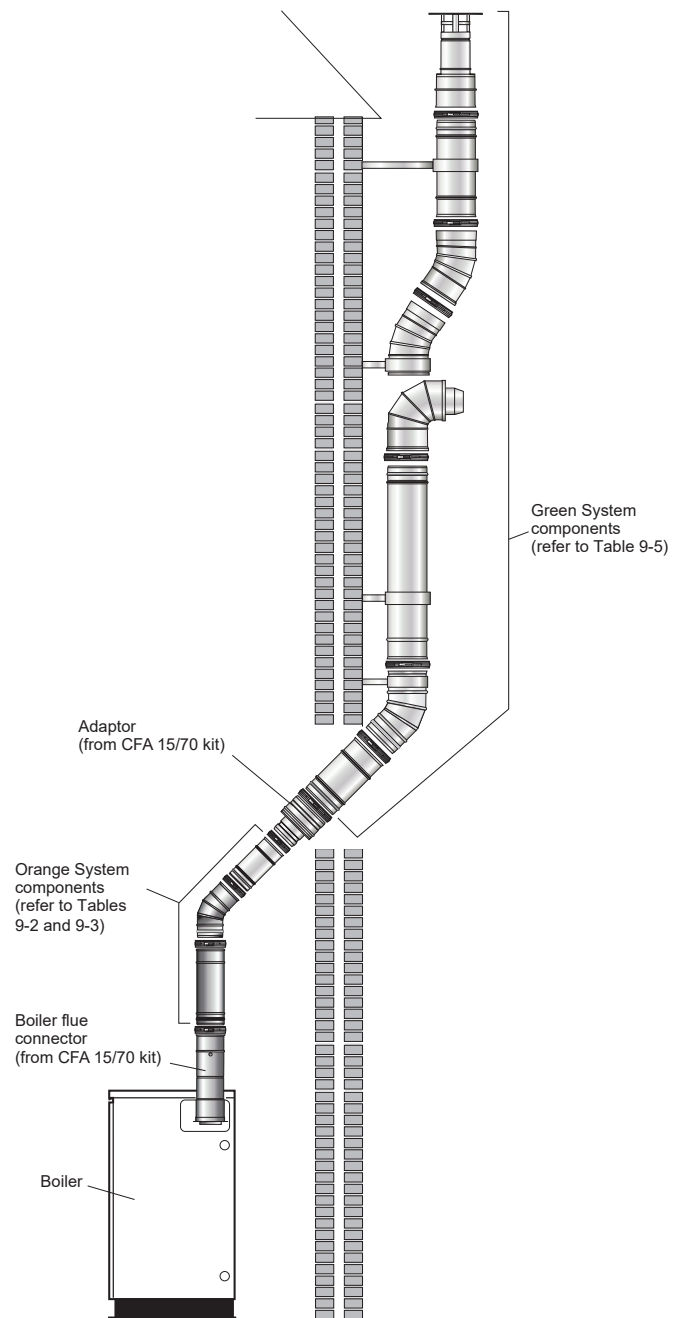

Figure 9-4: Hybrid flue system using Grant Orange and Green systems components

9.3 CONNECTING A CONVENTIONAL FLUE

If the Grant 'Orange' flue system is being used – follow the instructions supplied with the flue kit.

If the Grant 'Hybrid' system, utilising components from the Grant Green and Orange flue systems, is to be fitted to the boiler then the Grant CF adaptor kit (product code: CFA15/70) must be used – refer to both Section 1.3 and Figure 9-4.

To fit the adaptor kit, proceed as follows:

1. Fully screw the length of threaded studding (provided in the kit) into the nut located in the centre of the boiler flue outlet.
2. Fit the boiler connector (from the CF adaptor kit) over the threaded studding.
3. Position flange on to the neoprene gasket around the boiler flue outlet, ensuring that small spigot on the base of the connector is located in the hole in the centre of the neoprene gasket and that end of studding passes through the hole in the of the spacer bracket.
4. Fit washer and wing nut provided onto the end of threaded studding and secure connector in position by tightening down on wing nut – as shown in Figure 9-5.
5. Fit the flue adaptor (from the adaptor kit) into the boiler connector.

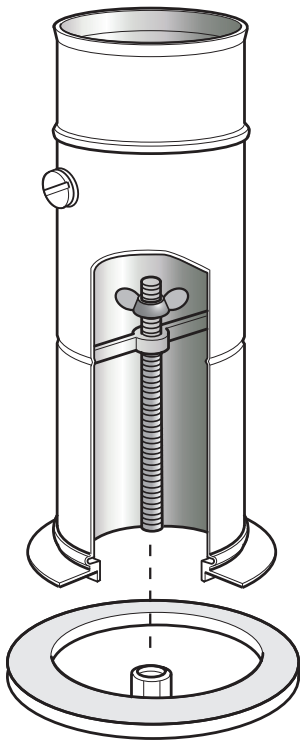

Figure 9-5: Boiler flue connector

! NOTE !

Lubricate the seal on the adaptor using the lubricant provided before attempting to fit the flue adaptor.

6. Fit the first section of flue into the flue adaptor and secure using the clamp band provided.
7. Assemble the remainder of the flue system as required, lubricating the seal on each component before fitting.

9.4 BALANCED FLUE SYSTEMS

Apart from a conventional flue, several balanced flue options are available for use with the Grant Vortex boilers.

All are suitable for use with Class C2 Kerosene.

! NOTE !

None of the flue sections in the following systems can be cut.

LOW LEVEL HORIZONTAL BALANCED FLUE (YELLOW SYSTEM)

Available in Short (for single thickness brick walls) and Standard kits.

Extensions are available which extend the flue by 225 mm, 450 mm or 675 mm. (For internal use only).

90° and 45° elbows are also available. (For internal use only).

The maximum flue length - from the centre of the boiler flue outlet to the outer face of the wall - is 4 metres (with or without elbows included).

No more than 2 x 45° or 1 x 90° elbow should be fitted per system.

The low level balanced flue (Yellow system) is supplied with a stainless steel guard. This must be fitted in all circumstances to prevent objects from entering the flue outlet.

The guard must be fitted centrally over the flue terminal and securely fixed to the wall.

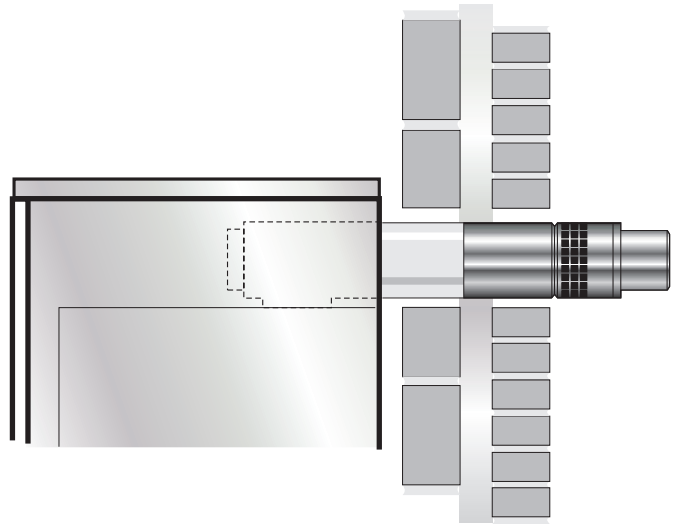

Figure 9-6: Low level balanced flue

PLUME DIVERTER KIT FOR LOW LEVEL BALANCED FLUE (YELLOW SYSTEM)

Should the low level balanced flue supplied with the boiler be discovered to cause a plume nuisance after its installation, a plume diverter kit is available to purchase from Grant UK for the purpose of re-directing the flue gases to a higher level (according to the minimum clearances shown in Figure 9-13).

The plume diverter kit has been designed to be retrofitted to an existing yellow system low level balanced flue by attaching directly to the low level terminal supplied with the boiler.

This kit is available in two sizes, product codes as follows:

- GDPA90B - suitable for installations of up to 26kW (maximum vertical length of 2.08m)
- GDPA200B - suitable for installations ranging from 26-70kW. (maximum vertical length of 2.14m)

While every effort has been made to make this retrofit as simple as possible for the installer, it is necessary for the installer to drill an 8mm hole in the side of the existing flue terminal to ensure that the condensate produced by the flue gases during normal operation drain back into the boiler.

It is also necessary for the installer to spot drill two 3mm holes in the existing flue terminal. With the plume diverter starter elbow in its final position on the existing flue terminal, use the holes in either side of this elbow as a guide to drill the two holes in the terminal and fix the elbow to the existing terminal by driving one of the two self-tapping screws provided into each hole.

More detailed installation instructions for this system can be found in the fitting instructions supplied with the kit.

Please see Figure 9-7 for a visual representation of the contents of the plume diverter kit.

A series of extensions and other accessories are available for use with this kit. Please contact Grant UK for further information.

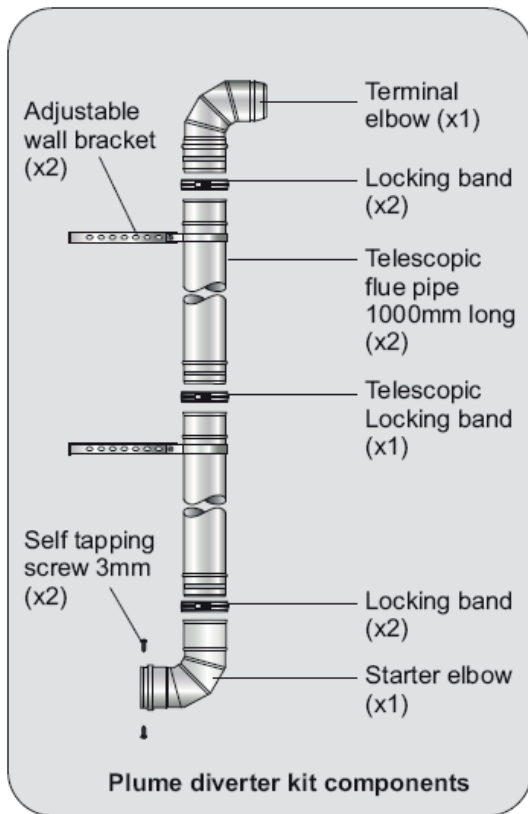

Figure 9-7: Yellow system Plume Diverter Kit

VERTICAL / HIGH LEVEL (HORIZONTAL) BALANCED FLUE (WHITE SYSTEM)

VERTICAL SYSTEM

This version of the White system allows the flue to rise vertically from the boiler to exit vertically through the roof by utilising a vertical terminal with an integrated cowl.

The maximum flue length for this system - from the top of the boiler flue outlet to the terminal - is 12 metres for all Grant Vortex boilers.

HIGH LEVEL (HORIZONTAL) SYSTEM

This version of the White system allows the flue to rise vertically within the building before exiting horizontally through the wall by utilising a terminal with a 90° bend.

The maximum flue length for this system - from the top of the boiler flue outlet to the outer face of the wall - is 10 metres for all Grant Vortex boilers.

Refer to Figure 9-8 for a visual representation of the High Level White system.

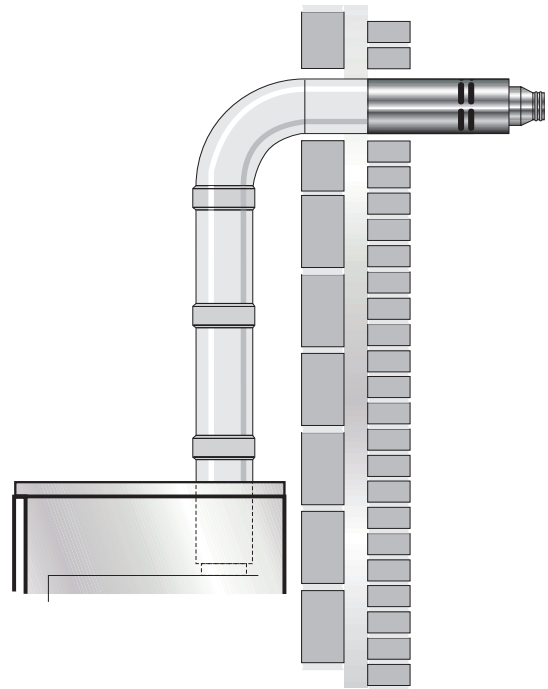

Figure 9-8: High level balanced flue

The following items are additionally available for BOTH versions of the White system:

- Extensions to extend the flue by 225 mm, 450 mm or 950 mm.
- An adjustable extension of 275 to 450 mm.
- A 45° elbow - No more than 6 x 45° elbows should be fitted per system. Each elbow reduces the overall maximum length of the system by 1 metre.

Two types of locking band are supplied with each kit, as follows:

- **Type 1.** A white painted band - for connecting fixed joints together, i.e. any joint that does not slide.
- **Type 2.** A white painted band - to cover the sliding joint on the adjustable (telescopic) section.

! NOTE !

The locking band for the adjustable section is labelled for easy identification.

Refer to Table 9-4 for a list of White system components and their product codes.

Table 9-4: White system components - product codes

Item	Combi 21 and 26 models	Combi 36 models
1.2 metre high level adjustable flue kit c/w 90° elbow and terminal	HLK015090	HLK0290200
Adjustable vertical 3 metre flue kit c/w terminal and storm collar	VTK055090	VTK0690200
225 mm extension	EXTK31225/90	EXTK32225/200
450 mm extension	EXTK09450/90	EXTK10450/200
950 mm extension	EXTK11950/90	EXTK12950/200
275 to 450 mm adjustable extension	EXTK13ADJ/90	EXTK14ADJ/200
45° elbow	ELBK2145/90	ELBK2245/200
Pitched roof flashing - aluminium (VTK055090 and VTK0690200)	VTMF200	
Pitched roof flashing - lead	VTK25P90 (includes collar)	VTK26P240 (no collar) VTK26P200/X (includes collar)
Flat roof flashing - aluminium	VTK27F90	VTK28F200
Wall bracket	BRK2990	BRK30200

FLEXIBLE VERTICAL BALANCED FLUE (RED SYSTEM)

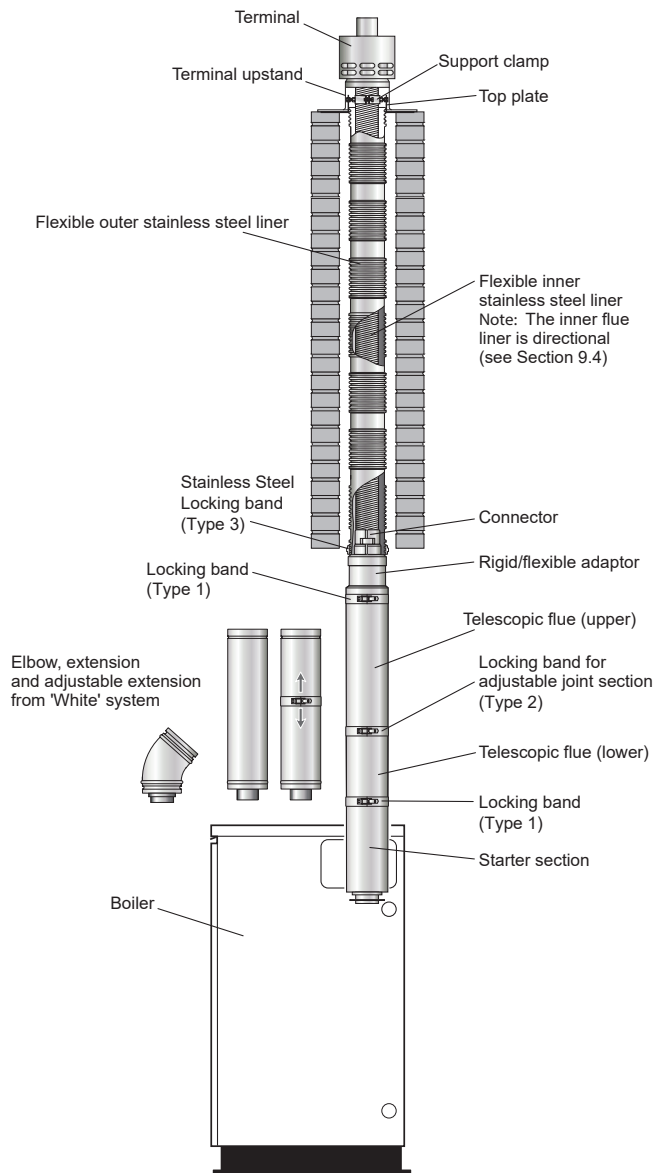

Figure 9-9: Red system balanced flue

This is a flexible vertical balanced flue system (for the Combi 21 and Combi 26 models only) designed to be fitted inside an existing masonry chimney. See Figure 9-9.

It basically consists of three sections:

- Concentric white painted flue pipe connected to the boiler.
- The vertical concentric flexible flue consists of a flexible stainless steel inner flue liner (directional) inside a flexible stainless steel outer flue liner.
- Terminal assembly for chimney top mounting.

The flue pipe seals are factory fitted and must be lubricated with the lubricant supplied before assembly.

The Red system is supplied as a separate kit. Flue extensions and 45° elbows from the White system may be used to extend the flue between the boiler and the flexible section of the system.

The maximum vertical straight length of flue, from the top of the boiler to the top of the terminal, is 20 metres – using no more than four 45° elbows. Deduct 1 metre of straight flue length for every elbow used.

! NOTE !

If the flexible liners must pass around an offset inside the chimney, deduct two metres of straight flue length to compensate for this.

The Grant Red system flexible stainless steel liner is directional. The arrows marked on the inner liner MUST be pointing vertically upwards, following the direction of the flue gases. Failure to comply with this instruction could lead to a leakage of condensate from the flue liner.

Flue extensions cannot be cut, use adjustable extensions where required.

Three types of locking band are supplied with the kit, as follows (Refer to Figure 9-9):

- **Type 1.** A white painted band - for connecting the white painted flue sections that butt together, i.e. the joints with the starter section and the rigid/flexible adaptor.

! NOTE !

Two of this type of locking band are supplied in the kit. Refer to Figure 9-9.

A single locking band of this type is supplied with every additional elbow, extension kit or adjustable extension kit used.

- **Type 2.** A white painted band - to cover the sliding joint on the white painted adjustable (telescopic) section.

! NOTE !

The locking band for the adjustable section is labelled for easy identification.

A single locking band of this type is supplied with every additional adjustable extension kit used.

- **Type 3.** An unpainted stainless steel band - to secure the outer of the two stainless steel flue liners to the white painted rigid/flexible adaptor.

The flue kit includes a Black coated terminal with upstand and is designed to be fixed (using the screws provided) to the top of a masonry chimney.

The flue system may be offset using 45° elbows (product code: ELBK2145/90 models up to 26 kW output).

No more than a maximum of four elbows should be used per system.

EXTERNAL BALANCED FLUE (GREEN SYSTEM)

Where it is not practical to use a low level (Yellow system) or internal high level/vertical (White system) balanced flue, the boiler can be fitted with an external vertical/high level flue (Green system).

See Figure 9-10.

The Starter kit fits to the boiler in the same way as a low level balanced flue (Yellow system) and the external Tee allows the connection of a twin wall insulated flue pipe and a combustion air inlet - providing a room sealed flue system.

The external system can terminate at either high level or vertically (above roof level) as required.

See Figure 9-10.

The minimum dimensions for locating the terminal from building features (windows, doors, etc.) are shown in Figure 9-13.

The terminal must be positioned so as to avoid products of combustion accumulating in stagnant pockets around the buildings or entering into buildings. Care should be taken that the plume from condensed flue gases does not cause a nuisance.

The components listed on the following page for the external flue (Green system) components are available from Grant UK.

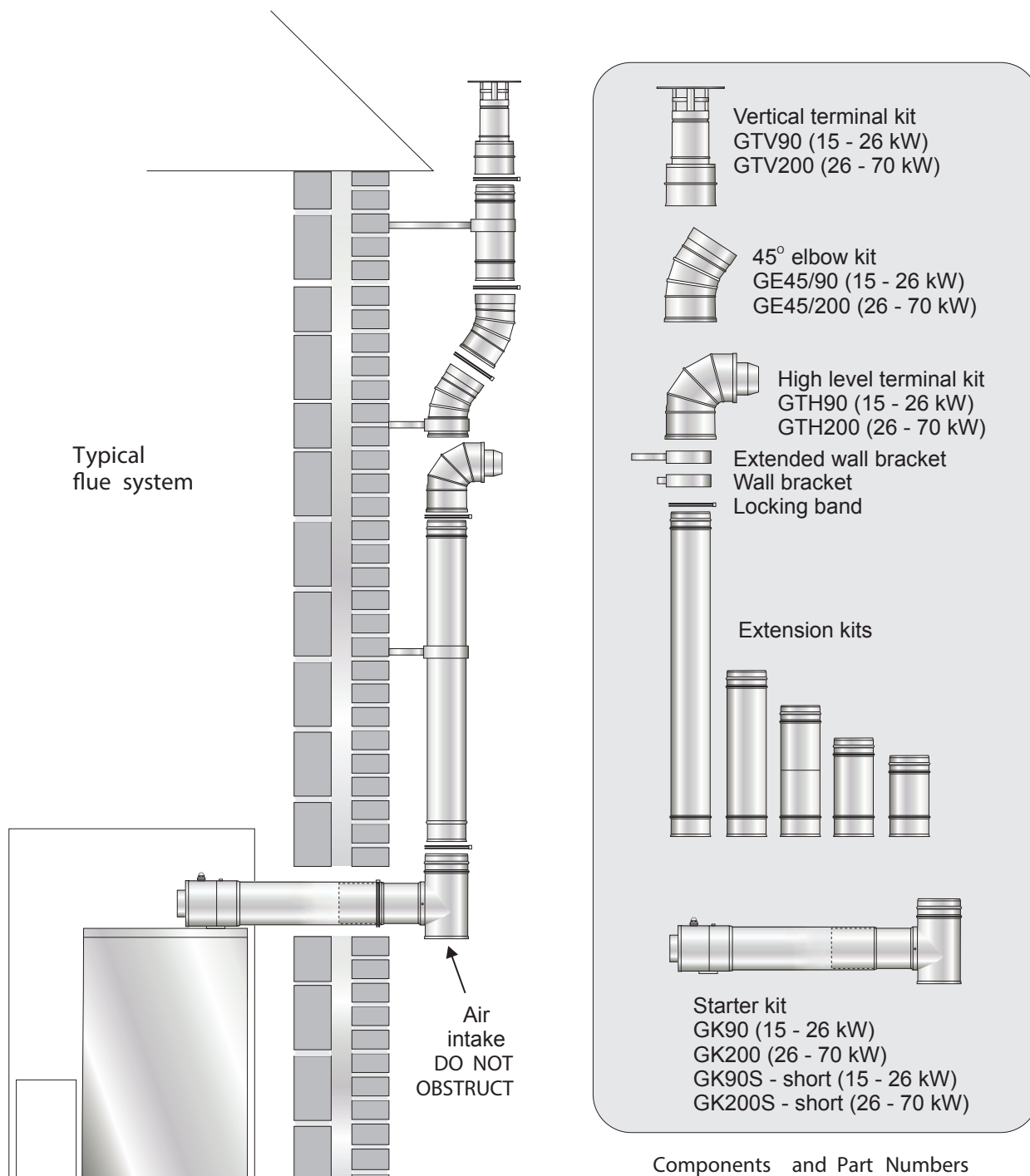

Figure 9-10: External balanced flue (green system)

Table 9-5: Green system components - product codes

Item	Combi XS 26, 21 and 26 models	Combi 36 models
Standard starter kit (stainless steel)	GK90B	GK200B
Short starter kit (stainless steel)	GK90SB	GK200SB
150 mm extension	GX150/90B	GX150/200B
250 mm extension	GX250/90B	GX250/200B
450 mm extension	GX450/90B	GX450/200B
950 mm extension	GX950/90B	GX950/200B
195 - 270 mm adjustable extension	GXA250/90B	GXA250/200B
45° elbow	GE45/90B	GE45/200B
Straight terminal	GTL90B	GTL200B
High level 90° terminal	GTH90B	GTH200B
Vertical terminal	GTV90B	GTV200B
Wall bracket - standard	GWB90B	GWB200B
Wall bracket - extended	GEB90B	GEB200B

9.5 PREPARE THE WALL

9.5.1 LOW LEVEL BALANCED FLUE

If the boiler is to be used with a low level balanced flue (Yellow system) make the hole in the wall for the flue as shown in Figure 9-11.

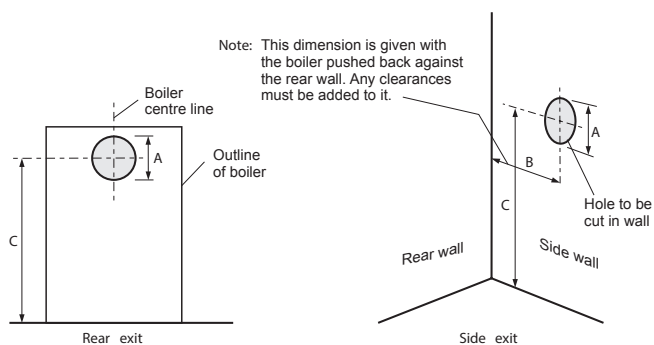

Figure 9-11: Flue hole dimensions and position for low level system

Table 9-6: Low level balanced flue hole cutting dimensions

Model	Dimension (mm)		
	A (dia.)	B	C
21 & 26	127	120	764
36	162	120	786

! NOTE !

Dimension A given in Table 9-6 includes an extra 10 mm over the size of the terminal to provide clearance for fitting.

! NOTE !

Dimension C given in Table 9-6 includes the depth of the neoprene gasket on top of the heat exchanger when fully compressed to 2mm.

9.5.2 HIGH LEVEL AND VERTICAL BALANCED FLUE

If the boiler is to be used with the high level balanced flue (White system) make the hole in the wall as shown in Figure 9-12.

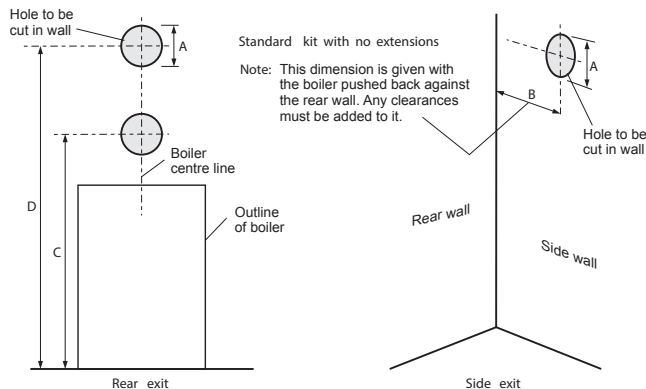

Figure 9-12: Flue hole dimensions and position for high level system

Table 9-7: High level balanced flue hole cutting dimensions

Model	Dimension (mm)			
	A (dia.)	B	C	D
21 and 26	175	120	1,229*	1,739 - 2,134**
36	200	120	1,281*	1,716 - 2016**

* Dimension C for starter section and elbow/terminal only

** Dimension D starter section, adjustable extension and elbow/terminal from white system only

! NOTE !

Dimension A given in Table 9-7 includes an extra 10 mm over the size of the terminal to provide clearance for fitting.

! NOTE !

Dimensions C and D given in Table 9-7 include the depth of the neoprene gasket on top of the heat exchanger when fully compressed to 2mm.

Fitting instructions for the high level balanced flue and vertical balanced flue are supplied with the flue kits.

Adjustable extensions

The adjustable extensions are telescopic.

The wall terminal section is adjustable and is suitable for a wall thickness of 215 mm to 450 mm.

Simply adjust to the required length using a twisting motion. The outer pipes must overlap by a minimum of 25 mm.

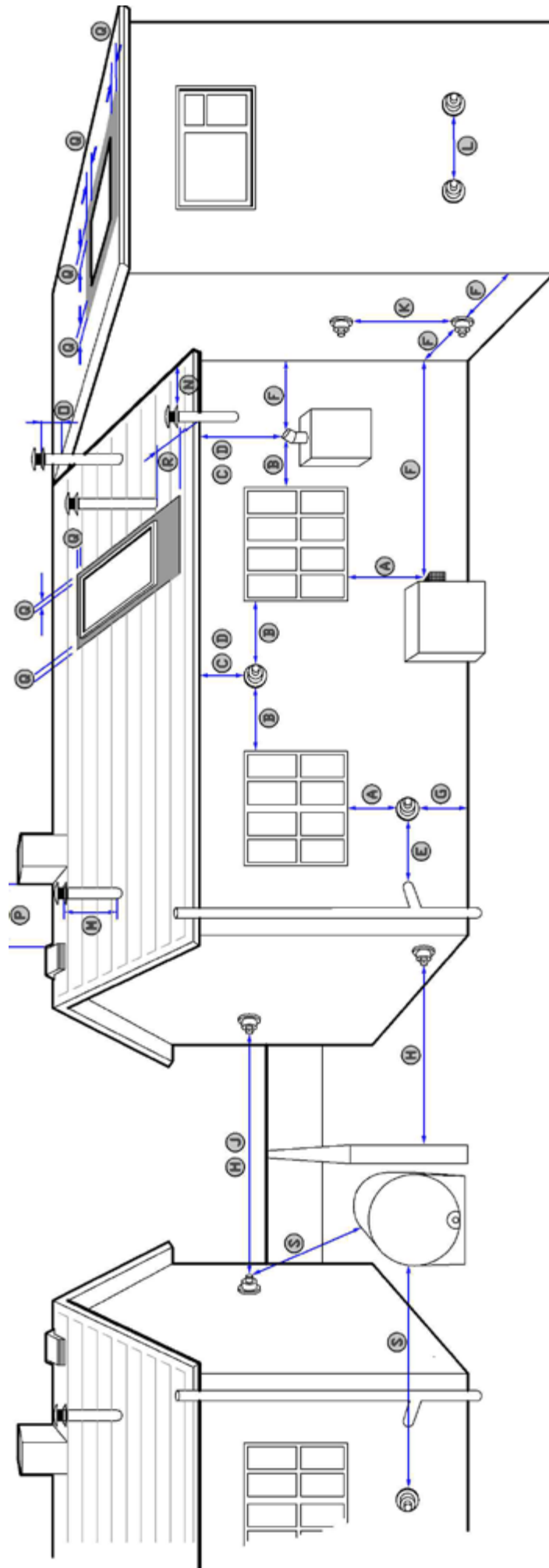

Figure 9-13: Flue clearances

Table 9-8: Flue clearances

Ref	Location of outlet	Minimum distance (mm)	
		Pressure jet	Condensing
A	Directly below an opening, air brick opening, opening window, etc.	600	1,000 **
B	Horizontally to an opening, air brick opening, opening window, etc.	600	1,000 **
C	Below a gutter, eaves or balcony with protection	75 *	1,000 **
D	Below a gutter, eaves or balcony without protection	600	1,000 **
E	From vertical sanitary pipework	300	
F	From an internal or external corner	300	
G	Above ground or balcony level	300	
H	From a surface or boundary facing the terminal	600	2,500 **
J	From a terminal facing the terminal	1,200	
K	Vertically from a terminal on the same wall	1,500	
L	Horizontally from a terminal on the same wall	750	
M	Above the highest point of an intersection with the roof	600	
N	From a vertical structure to the side of the terminal	750	
O	Above a vertical structure less than 750 mm from the side of the terminal	600	
P	From a ridge terminal to a vertical structure on the roof	1,500	
Q	Above or to the side of any opening on a flat or sloping roof	300	
R	Below any opening on a sloping roof	1,000	
S	From oil storage tank (Class 1)	1,800 ***	

* A heat shield at least 750 mm wide must be fitted to provide protection of combustible material.

** Clearances required by BS 5410-1:2019 to alleviate the effect of plume nuisance. If a risk assessment shows that there will be no impact from pluming, then the 'pressure jet' figure could apply - seek confirmation from Local Authority Building Control.

*** Seek guidance from OFTEC Book 3 (Oil Storage and Supply).

NOTES

- Appliances burning class D fuel have additional restrictions. Refer to BS 5410-1:2019.
- Vertical structure in N, O and P includes tank or lift rooms, parapets, dormers, etc.
- Terminating positions A to L are only permitted for appliances that have been approved for low level flue discharge when tested in accordance with BS EN 303-1, OFS A100 or OFS A101.
- Terminating positions should be at least 1.8 metres from an oil storage tank (Class 1) unless a wall with at least 30 minutes fire resistance and extending 300 mm higher and wider than the tank is provided between the tank and the terminating position.
- Where a flue is terminated less than 600 mm away from a projection above it and the projection consists of plastics or has a combustible or painted surface, then a heat shield of at least 750 mm wide should be fitted to protect these surfaces.
- If the lowest part of the terminal is less than 2 metres above the ground, balcony, flat roof or other place to which any person has access, the terminal should be protected by a guard.
- Notwithstanding the dimensions given above, a terminal should not be sited closer than 300 mm to combustible material. In the case of a thatched roof, double this separation distance should be provided. It is also advisable to treat the thatch with a fire retardant material and close wire in the immediate vicinity of the flue.
- A flue or chimney should not pass through the roof within the shaded area delineated by dimensions Q and R.
- Where protection is provided for plastics components, such as guttering, this should be to the standard specified by the manufacturer of the plastics components.
- Terminals must not be sited under car ports.
- Terminals at low levels (terminals under 2.1 metres) have more restrictive recommendations and should not be positioned near public footways, frequently used access routes, car parking spaces less than 2.5 metres from the terminal or patio's (hard surface area).

Further guidance can be obtained from BS 5410-1:2019, OFTEC Book 4 (Installation) and Approved Document J.

Grant UK flue products are fully compliant with the CE (Communauté Européenne/European Community) standards having undergone rigorous product testing.

10 COMMISSIONING

To ensure safe and efficient operation, it is essential that a Grant VortexBlue boiler is commissioned as detailed in the following procedure.

To access the controls, remove the front panel from the boiler (pull forward at the top and then lift off).

The controls are shown in Figure 10-1.

10.1 BEFORE SWITCHING ON

1. Ensure the boiler is isolated from the electrical supply and the boiler ON/OFF switch is set to OFF.
2. Check that the high limit thermostat bulb and both thermistor sensors are correctly located in their respective pockets. Refer to Figures 5-1 and 10-2. Check condition of both thermistor cables and thermostat capillary. Ensure they are not damaged, broken, kinked or crushed.
3. Remove the nuts and washers securing the front cleaning door. Withdraw the door – take care as it is heavy!
4. Check that the turbulators are in position and that the ends are vertical. Refer to Figure 11-3.
5. Check that the baffles are in position. Refer to Figures 11-1 and 11-2 as required.
6. Re-fit cleaning door and check it is fitted correctly and that a good seal is made.
7. Unscrew the burner fixing nut (located at the top of the mounting flange) and remove the burner from the boiler.
8. Check/adjust the burner settings as described in Section 10.2 (Burner Settings).
9. Re-fit the burner to the boiler and tighten the fixing nut. **DO NOT OVERTIGHTEN!**
10. Check that the sealed system has been vented and pressurised and there are no leaks.
11. Ensure all air vents are open. Refer to Figure 5-1.
12. Check that all fuel line valves are open.
13. Remove the plastic burner cover if it was not previously removed.
14. Connect a combined vent manifold and pressure gauge to the pressure gauge connection port on the oil pump. See Figure 3-5. Open the vent screw on the vent manifold to vent the oil supply whilst the pump is running.
15. Check that all system controls are calling for heat and turn the boiler thermostat to maximum.

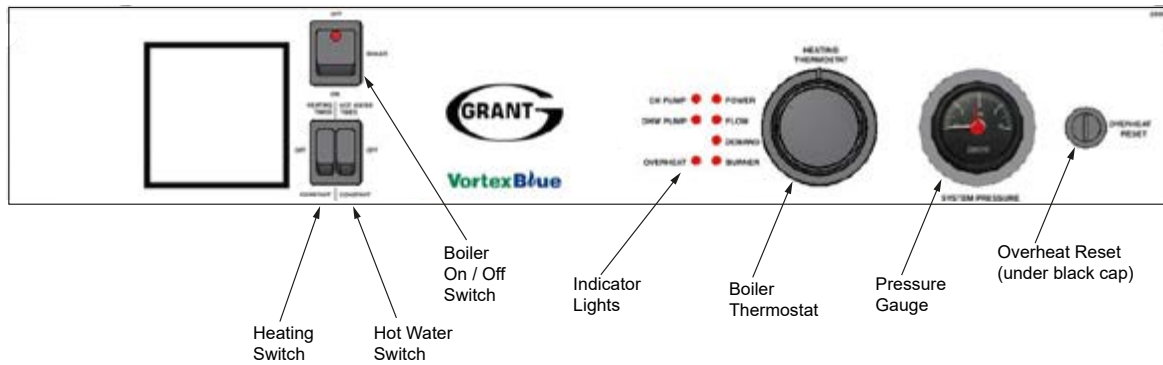

Figure 10-1: VortexBlue Internal Combi control panel

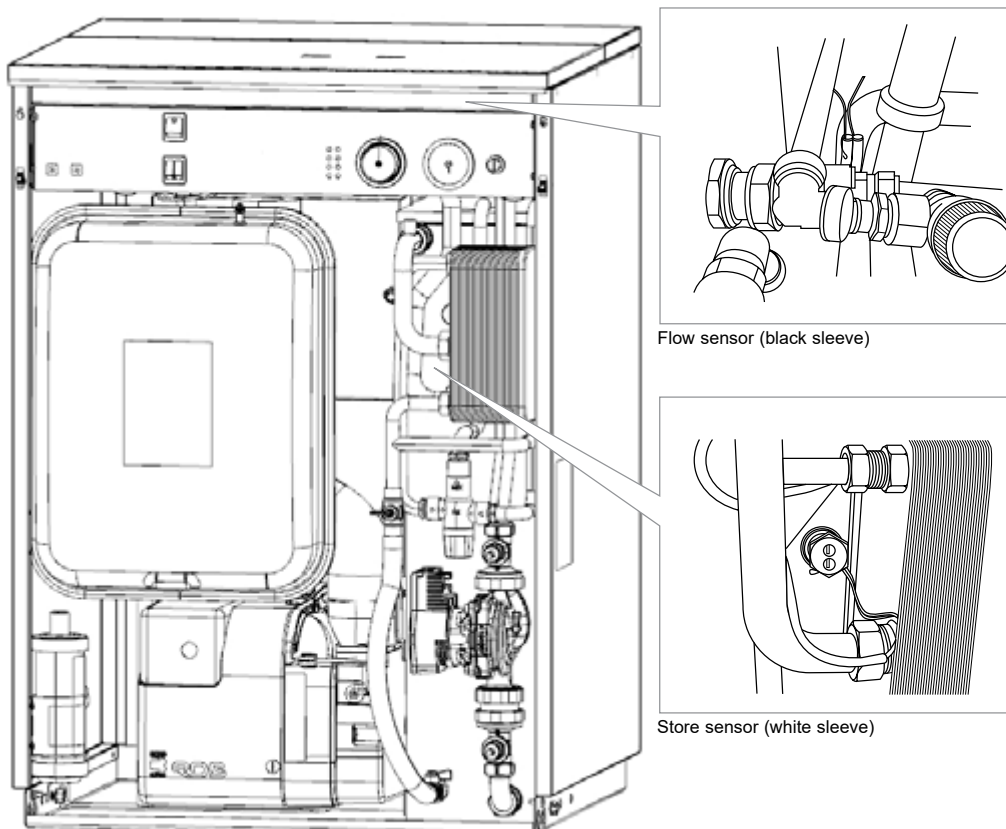

Figure 10-2: Position of boiler components - VortexBlue Combi boiler

10.2 BURNER SETTINGS: RDB2.2 BG BLU BURNERS

FOR ALL MODELS

With the burner removed from the boiler:

1. Remove the burner head. Refer to Figure 10-3. Loosen the two fixing screws (1) and carefully separate the head (2) from burner.

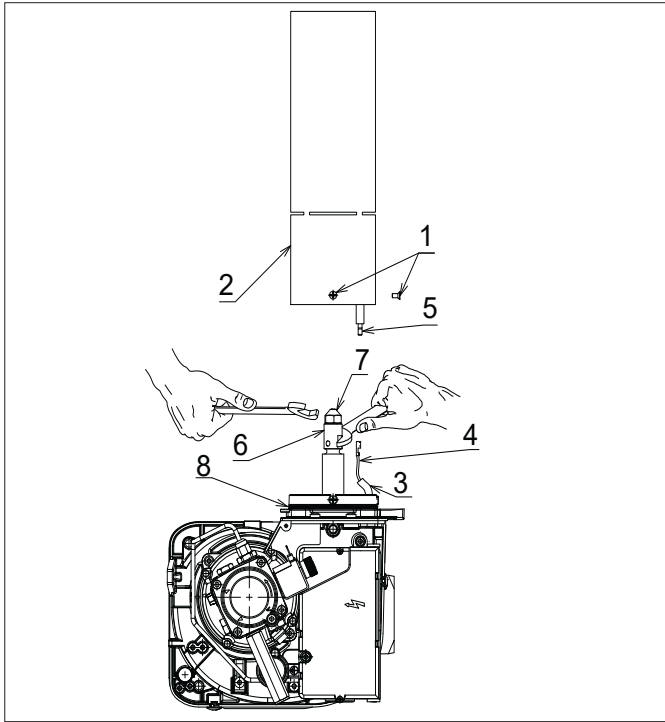

Figure 10-3: Burner head and nozzle holder

2. Refer to Figure 10-3. Disconnect both ignition leads (4) from the electrodes (5).
To do this:
 - Carefully slide the insulative sleeve (3) down the ignition lead and away from the metal connectors.
 - Grasp the metal connector - not the ignition lead - and pull it off the electrode.
 - Repeat this for the second ignition lead.
3. Check the nozzle (7) is correct for the required boiler output. Refer to Table 2-2 for the correct nozzle size and type for the required boiler output.
4. Use a 16 mm spanner to remove/re-fit the nozzle (7), whilst holding the nozzle holder (6) using a 17 mm spanner.

! CAUTION !

The use of an ill-fitting spanner will damage the nozzle and could lead to an incorrect flame pattern and poor combustion.

! NOTE !

Ensure that the nozzle is securely tightened so that it does not leak but DO NOT OVER TIGHTEN!

5. Check/adjust electrode setting. Refer to Figure 10-4.
6. Reconnect the ignition leads to the electrodes, as follows. Refer to Figure 10-3.
 - First, ensure the insulative sleeve (3) is slid down the ignition lead and is not covering the metal connector.
 - Firmly push the metal connector (4) on to the electrode (5).
 - Carefully slide the insulative sleeve (3) to fully cover the metal connector (4) on the ignition lead.
 - Repeat this for the second ignition lead.

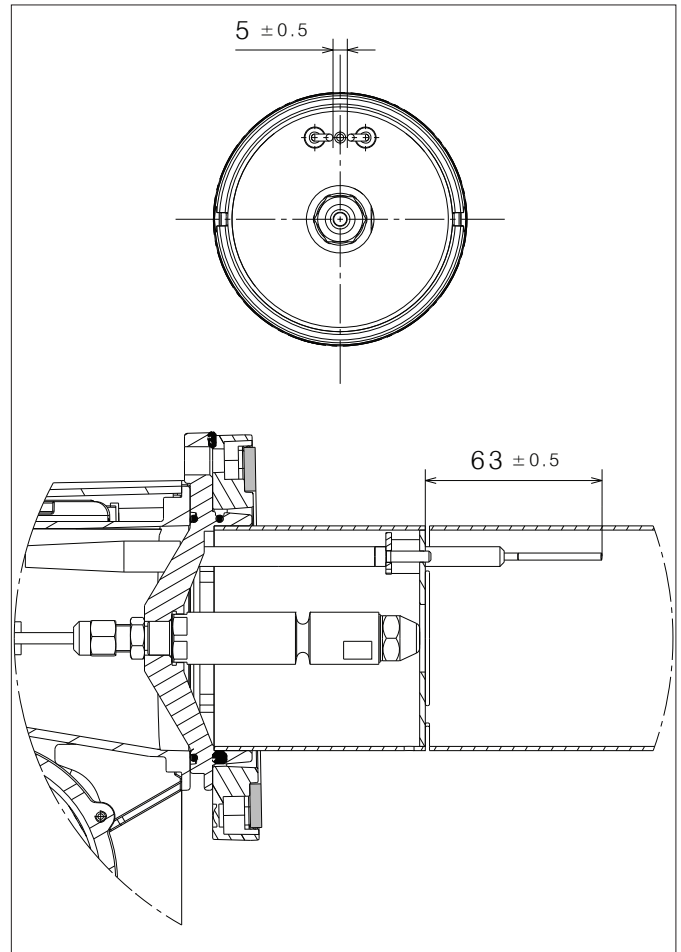

Figure 10-4: Ignition electrode settings

7. Re-fit the burner head. Refer to Figure 10-3.
 - Check the electrodes are at the top of the head.
 - Locate the head fixing screws (1) in the countersunk slots in the burner collar.
 - Tighten the two screws (1) to secure the head (2) in position on the burner.

10.3 SWITCHING ON

1. Check that all system controls are calling for heat and turn the boiler thermostat to maximum.
2. Switch on the electricity supply to the boiler.
3. Set the boiler On/Off switch to ON. A neon on the switch lights when it is in the ON position. The boiler will now light automatically.

Note that the neon lights when the boiler is switched on, but does not necessarily indicate the burner is firing.

Set both the Hot Water and Heating switches to ON. The burner should then fire. Open the vent screw on the vent manifold to vent the supply while the oil pump is running

4. Fully open a hot tap and allow it to run for a few moments to vent the internal primary circuit. The Hot Water pump will operate and the burner should light within about 12 seconds. If the burner does not light and the 'Lock-out' reset button lights, wait for about 45 seconds then press the reset button to restart the ignition process. This procedure may have to be repeated during first lighting.
5. Close the hot tap. The burner will continue to fire to heat the primary water in the boiler or primary store until the required temperature is reached.

! NOTE !

Grant Vortex Combi boilers incorporate a "pump overrun" feature, within the control circuit board, that operates as follows:

- **When reheating the Primary Hot Water store:** the burner will cut out when the boiler reaches 83°C (as detected by the boiler "flow" thermistor).
- **If there is a demand for Central Heating:** the hot water "store" pump will run on for 90 seconds before it stops and the "central heating" pump then comes in.
- **If there is no demand for Central Heating:** the hot water "store" pump will continue to run until the temperatures in the Primary Hot Water store and the boiler have equalised. The adjustable Boiler thermostat on the control panel regulates the boiler temperature when in Heating mode only. The recommended flow temperature setting is 70°C.

The Primary Hot Water store temperature is controlled via the "store" thermistor and control circuit board. The control thermostat has NO influence on either the store temperature or the hot water temperature at the tap.

! NOTE !

The hot water pump will continue to run for a short period after the burner has stopped.

The boiler will now be operating in the central heating mode.

! NOTE !

The burner may not fire immediately in the central heating mode.

6. With the burner alight, check the fuel pressure. Refer to Section 2.2 (burner settings).
7. Adjust the pressure if necessary - refer to Figure A1-1 in Appendix A1 towards the back of this manual.

! NOTE !

It is important that the oil pressure is correctly set.

8. Operate the boiler until it reaches normal operating temperature. Check oil supply/return pipe for leaks, rectifying where necessary.

9. Check the operation of the boiler thermostat. Ensure that by turning it anticlockwise it switches the burner off.
10. With the burner alight, re-check the fuel pressure and re-adjust if necessary. Turn the boiler off, remove the pressure gauge and replace the plug in the pump.
11. Ensure that there are no oil leaks, replace the burner cover.
12. On balanced flue installations - Ensure the flexible air inlet tube is correctly connected to both the burner air inlet and the flue system.

10.4 RUNNING THE BOILER

1. Relight the boiler and allow it to run for at least 20 minutes.
2. Check the smoke number, if it is 0-1 then it is satisfactory.
3. Using a calibrated electronic flue gas analyser, set to the correct fuel, check the %CO₂ in the flue gases.

! NOTE !

To allow the boiler to be commissioned and serviced correctly a combustion test point is provided on the front cleaning door. Both the %CO₂ and smoke test may all be carried out using this test point.

This test point is not suitable for measuring boiler efficiency or conventional flue draught.

4. When using the test point on the cleaning cover note that the flue gas temperature reading will be higher than that measured in the flue thus resulting in an inaccurate efficiency reading. To obtain an accurate flue gas temperature and efficiency, the reading can only be measured outside through the low level flue terminal (or the test point on the conventional flue starter section when used).
5. For high level and vertical balanced flues, the reading may be taken from the flue test point provided on the flue system. Refer to Section 9.
6. For conventional flues, a test point is provided in the conventional flue adaptor for flue draught and flue gas temperature measurement. Refer to Section 9.
7. Set the %CO₂, as indicated on the flue gas analyser, to the required value as given in Section 2.2 for the boiler concerned.
8. Adjust the burner air damper, using the hexagonal key supplied, to achieve the required %CO₂. Refer to Figure A1-1 in Appendix A1 towards the back of this manual.
9. To increase the %CO₂:
 - Turn the screw anti-clockwise. This will close down the burner air damper and decrease the combustion air entering the burner.To decrease the %CO₂:
 - Turn the screw clockwise. This will open up the burner air damper and increase the combustion air entering the burner.
10. When the %CO₂ is set to the correct level, re-check the smoke number if the burner air damper has been moved. Under no circumstances must the smoke number be above 1.

! NOTE !

For safe and efficient operation of the boiler it is essential that the air damper is correctly set to give the required %CO₂ in the flue gases.

10.5 BALANCING THE SYSTEM

1. When the boiler has been adjusted and is running satisfactorily, balance the central heating system by adjusting the radiator lock shield valves.
Start with the radiator nearest the boiler and adjust the valves to achieve the required temperature drop across each radiator.
If thermostatic radiator valves have been installed, check the system bypass.
2. Switch off the boiler.

10.6 COMPLETION

1. With the system hot, check again for leaks, rectifying where necessary. Drain the system while it is hot to complete the flushing process. Refill and vent the sealed system.
2. A suitable central heating system inhibitor must be added to protect the system against the effect of corrosion.
3. A suitable antifreeze should be used to prevent damage to the boiler in areas where electrical power failure can occur in winter months.
4. Replace the top, front and rear panels as necessary.

! NOTE !

After commissioning the boiler complete the OFTEC CD/11 commissioning report. Leave the top copy with the user and retain the carbon copy.

If the boiler is to be left in service with the User, set the controls and room thermostat (if fitted) to the User's requirements.

If the boiler is not to be handed over immediately, close the boiler fuel supply valve and switch off the electricity supply.

! CAUTION !

If there is any possibility of the boiler being left during freezing conditions, then the boiler and system should be drained. Alternatively, a suitable heating system antifreeze should be used.

10.7 INFORMATION FOR THE USER

The User must be advised (and demonstrated if necessary) of the following important points:-

- How to start and switch off the boiler and how to operate the system controls.
- The precautions necessary to prevent damage to the central heating system and to the building, in the event of the boiler not being in operation during frost conditions.
- The importance of servicing the boiler to ensure safe and efficient operation. This should normally be required only once a year.
- The type of fuel used.
- That any servicing or replacement of parts must only be carried out by a suitably qualified engineer.
- Ensure that the boiler controls and room thermostat (if fitted) are set to the User's requirements.
- Tell the User the system pressure and show them the position of the safety valve discharge pipe.
- Show the User how to reset the overheat thermostat and how to restart the boiler if it goes to 'Lockout'.

11 SERVICING

To ensure safe and efficient operation it is essential that a Grant Combi boiler is serviced at regular intervals of no longer than 12 months.

Servicing and replacement of parts must only be carried out by a suitably qualified engineer.

! CAUTION !

Details of every service should be entered in the Service Log, in the Boiler Handbook.

This information may be required to validate the Grant extended guarantee.

! WARNING !

Before starting any work on the boiler or fuel supply, please read the Health and Safety information given in Section 15 of these Instructions.

11.1 CHECKS BEFORE SERVICING

The following sequence of checks should be made before starting any servicing work:

1. Check the flue terminal and ensure it is not blocked or damaged.
2. Run the boiler and check the operation of its controls.
3. Ensure that all water system connections and fittings are sound. Remake any joints and check the tightness of any fittings that may be leaking.
4. Allow the boiler and system to cool down.
5. The boiler is part of a sealed central heating system, check the system pressure, check the operation of the pressure relief valve and check the expansion vessel air charge. Refer to Section 7.
6. Refill, vent and re-pressurise the system as necessary. Refer to Section 7.
7. Check that any ventilation openings are of adequate free area and are clear of obstructions. Refer to Section 9.
8. Remove any sludge/water from the fuel tank by opening the sludge valve at the lower end of the tank (if fitted).
9. Ensure that all fuel system connections and fittings are sound. Remake any joints and check the tightness of any fittings that may be leaking.
10. With the fuel supply valve (at the oil tank) closed, clean/replace the filter element and clean the filter bowl.

! WARNING !

Before servicing, set the boiler ON/OFF switch to OFF, isolate the electricity supply and close the fuel supply valve.

The data label on the inside of the case side panel will indicate the fuel used and the nozzle fitted.

11.2 DISMANTLING PRIOR TO SERVICING

The procedure for dismantling the boiler is as follows:

1. Remove the front panel from the boiler (pull forward at the top and lift off).
2. Carefully lift up the expansion vessel and remove it from the boiler. Place it on the floor, taking care not to strain the flexible pipe.
3. Disconnect the flexible air tube from the burner.
4. Unscrew and remove the two fixing screws and remove the

red cover from the burner.

5. Remove the burner fixing nut (located at the top of the mounting flange) and withdraw the burner from the boiler. If required, disconnect the flexible oil line(s), using a suitable container to prevent any oil spillage.
6. Check or replace the flexible fuel supply hose, as follows:
 - Braided flexible fuel supply hoses (as supplied with the boiler) should be replaced annually, i.e. when the boiler is serviced.
 - Long-life hoses should be inspected annually. If in doubt replace the hose(s). In any event, these hoses must be replaced every five years.

! NOTE !

With a two-pipe oil supply there will be two flexible hoses connected to the burner. Identify (mark if necessary) which is the inlet and return if they are to be disconnected.

11.3 CLEANING THE BOILER

The procedure for cleaning the boiler is as follows:

1. Remove the nuts and washers securing the front cleaning door and withdraw the door. Take care - it is heavy.
2. Remove the baffles as shown in Figure 11-1 and Figure 11-2.
3. Remove all deposits from the baffle plates and all the boiler internal surfaces using a stiff brush and scraper if necessary.
4. Check the condition of the flue, clean as necessary.
5. Check the condition of the front cleaning door seal and replace if necessary.
6. Replace the baffles, ensuring they are correctly fitted. Refer to Figures 11-1 and 11-2, as appropriate.
7. Pull out the spiral turbulators from the heat exchanger tubes. See Figure 11-3. Clean the turbulators using a stiff brush.
8. Test the heat exchanger condensate drain by pouring water into one of the lower tubes and observe whether the water discharges from the 22 mm condensate outlet. Replace the turbulators.
9. Replace the front cleaning door, ensuring the seal is in good condition and secure it in position with the nuts and washers previously removed. Tighten to form a seal.
10. Remove the condensate trap and check that it is not blocked and is operating correctly, i.e. the float is free to move. Clean the trap and float as required.
11. Check the condition of the flexible condensate hose between the trap and the boiler.
12. Check that the boiler condensate outlet is unobstructed. Clean if necessary.

! NOTE !

The condensate trap and condensate outlet must be checked on every service and cleaned as necessary. The end cap is not sealed to the trap body and can be removed for cleaning. Ensure that this cap is correctly re-fitted before re-starting the boiler.

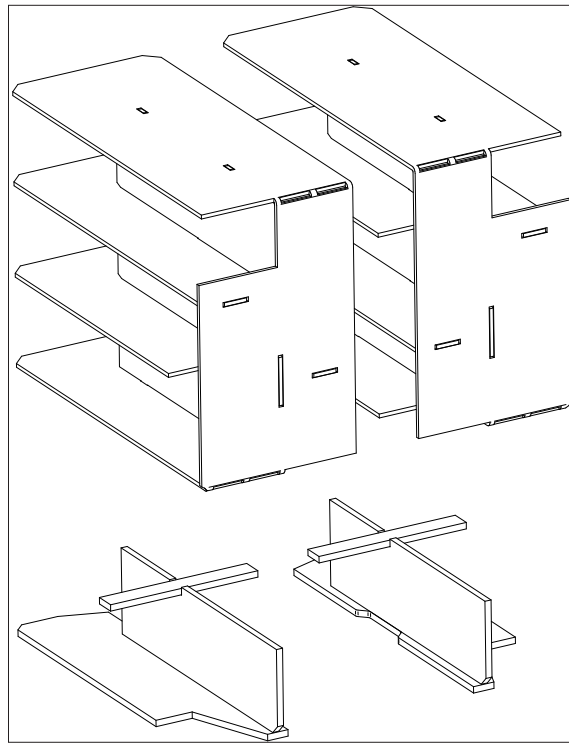

Figure 11-1: Baffles in VortexBlue Combi 21 & 26

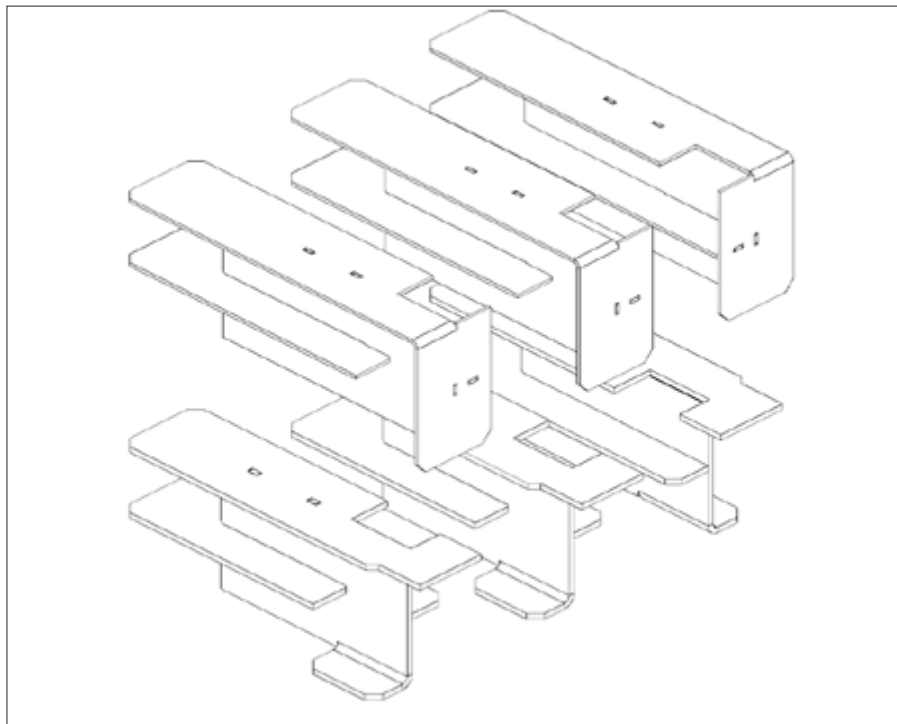

Figure 11-2: Baffles in VortexBlue Combi 36

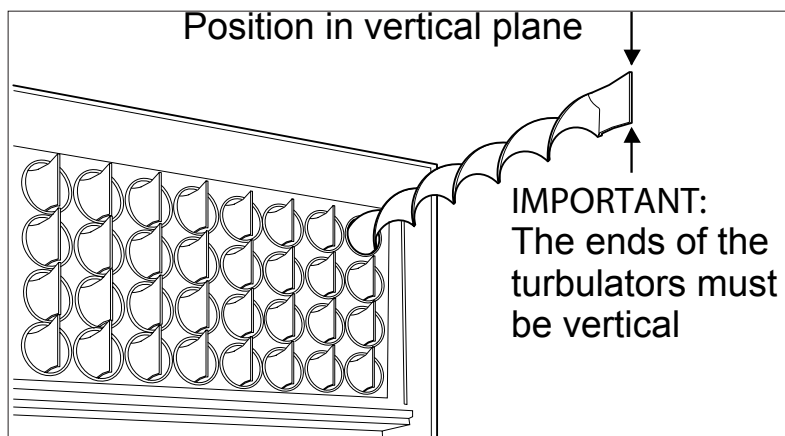

Figure 11-3: Turbulators in VortexBlue Combi boilers

11.4 CLEANING THE BURNER: RDB2.2 BG BLU BURNERS

FOR ALL MODELS

With the burner removed from the boiler:

Burner head, nozzle and electrodes:

1. Remove the burner head. Refer to Figure 10-3. Loosen the two fixing screws (1) and carefully separate the head (2) from the burner.
2. Inspect the burner collar o-ring (8) for signs of perishing. The burner collar o-ring should be inspected annually and replaced as necessary. Part code: Z3008878.
3. Refer to Figure 10-3. Disconnect both ignition leads (4) from the electrodes (5)
To do this:
 - Carefully slide the insulation sleeve (3) down the ignition lead and away from the metal connector.
 - Grasp the metal connector (4) - not the ignition lead - and pull it off the electrode.
 - Repeat this for the second ignition lead.
4. Clean the burner head.
5. Replace the nozzle (7). The nozzle should always be replaced on an annual service. Refer to Table 2-2 for the correct nozzle size and type for the required boiler output. Do NOT attempt to clean the nozzle.
6. Use a 16 mm spanner to remove/re-fit the nozzle, whilst holding the nozzle holder using a 17 mm spanner.

! CAUTION !

The use of an ill-fitting spanner will damage the nozzle and could lead to an incorrect flame pattern and poor combustion.

! NOTE !

Ensure that the nozzle is securely tightened so that it does not leak but **DO NOT OVERTIGHTEN!**

7. Inspect/clean the ignition electrodes.
To remove them from the burner head for inspection:
 - Using a 3mm allen key, unscrew and remove the electrode screw and retaining plate.
 - Carefully withdraw both electrodes from the burner head.
 - Wipe clean and check for any cracks in the ceramic insulation.
 - Replace if necessary.
8. Re-fit the electrodes and secure using screw and retaining plate.

! NOTE !

Do not overtighten the fixing screw as this may damage the electrode insulators.

9. Check/adjust the electrode setting. Refer to Figure 10-4.
10. Reconnect ignition leads to the electrodes, as follows. Refer to Figure 10-3.
 - First, ensure the insulation sleeve (3) is slid down the ignition lead and is not covering the metal connector.
 - Firmly push the connector (4) on to the electrode (5).
 - Carefully slide the insulation sleeve (3) to fully cover the metal connector (4) on the ignition lead.
 - Repeat this for the second ignition lead.
11. Re-fit the burner head. Refer to Figure 10-3.
 - Check that the electrodes are at the top of the head.
 - Locate the head fixing screws (1) in the countersunk slots in the burner collar.
 - Tighten the two screws (1) to secure the head (2) in position on the burner.

! NOTE !

When re-fitting the burner head ensure that the ignition leads do not obscure the UV cell.

11.5 CLEANING THE BURNER: OTHER COMPONENTS

UV Cell

The UV cell is a push-fit in the front of burner body. Refer to Figure A1-1 in Appendix A1 towards the back of this manual.

1. Holding the body of the UV cell and NOT the cable, carefully pull the UV cell out of the burner.
2. Clean the sensor end of the UV cell.
3. Check the sliding collar on the UV cell is positioned as far forward as possible on the body of the UV cell. Refer to figure 11-4.
4. Replace UV cell back in the burner and check that it is fully pushed in.

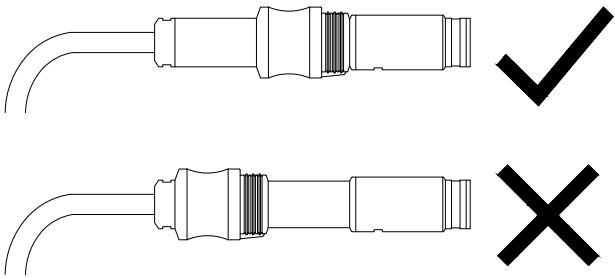

Figure 11-4: UV Cell Collar Position

Burner air inlet cover

This is located on the right hand side of the burner. Refer to Figure A1-1 in Appendix A1 towards the back of this manual.

1. Unscrew and remove the two screws and remove the air inlet cover from the burner.
2. Check inside and remove any debris, leaves, hair, fluff, etc. from the air inlet cover and air damper..
3. Check the condition of the rubber seal around the air inlet cover. Replace if damaged or missing.

Burner fan housing

This is located over the fan impeller. Refer to Figure A1-1 in Appendix A1 towards the back of this manual.

With the burner air inlet cover already removed:

1. Unscrew and remove the four screws and remove the fan housing from the burner.
2. Check and clean the fan impeller and remove any debris, leaves, hair, fluff etc.
3. Check the fan housing is clean and clean as required.
4. Check the rubber seal around the fan housing. Replace if damaged or missing.
5. Re-fit the fan housing to the burner and secure with the four screws.
6. Re-fit the air inlet cover to the burner and secure with the two screws.

Oil pump filter

This is located under the end cover on the oil pump. Refer to Figure A1-1 in Appendix A1 towards the back of this manual.

1. Unscrew and remove the four cap screws securing the pump end cover.
2. Remove the filter and wash in kerosene.
3. Check the O-ring seal around the end cover. Replace if damaged.
4. Replace the filter and end cover.
5. Re-fit the four cap screws, tightening evenly, to secure the end cap.

11.6 RECOMMISSIONING

! WARNING !

To ensure safe and efficient operation of the boiler it is important that recommissioning is carried out, especially combustion checks (%CO₂ level, flue gas temperature and smoke number) after the boiler has been serviced. Refer to the Commissioning instructions in Section 10.

12 FAULT FINDING

12.1 INITIAL CHECKLIST - FOR INSTALLERS OR SERVICE ENGINEERS

12.1.1 IF THE BOILER FAILS TO LIGHT

First follow the procedure below

Power supply	Check that the fused spur for the heating system is switched on. Check that the fuse has not blown. Check that the electricity supply has not failed; check circuit breaker in consumer unit.
Heating system controls	Check that the timer or programmer is working and set to an 'ON' period. Check that all thermostats are set to the required temperature and are 'calling' for heat.
Boiler controls	Check that the boiler 'ON/OFF' switch is set to 'ON'. Check that the 'POWER' demand indicator on the control panel is lit. Check that the 'DEMAND' indicator is lit.
Burner	Check if the burner lockout reset button (on front face of burner) is lit. If YES: press in the reset button to start the burner. If burner fails to light and goes to lockout again, refer to Section 12.4.
If burner still fails to light	Follow the 'burner not operating' procedure in Section 12.2 (C).

12.1.2 FOR HOT WATER - ALL THE FOLLOWING INDICATOR LIGHTS MUST BE LIT

POWER	If not lit, this indicates a problem with the power supply to the boiler - switched off or possibly blown a fuse.
DHW PUMP	If flashing, this indicates either a 'store' thermistor or PCB fault. Refer to the 'is the DHW PUMP indicator flashing' procedure in Section 12.2 (B).
FLOW	If not lit when a hot tap is opened, this indicates either a lack of water flow or possible flow switch problem.
DEMAND	If not lit, this indicates either timer/programmer is not 'calling' for hot water or 'hot water' switch is not set to 'constant'.
BURNER	If flashing, this indicates a PCB fault. Refer to the 'is the burner indicator lit' procedure in Section 12.2 (B).

NOTE: There may be a delay before the 'burner' indicator is lit when the store is up to temperature

12.1.3 FOR NIGHT TIME HOT WATER FUNCTION - ALL THE FOLLOWING INDICATOR LIGHTS MUST BE LIT

POWER	If not lit, this indicates a problem with the power supply to the boiler - switched off or possibly blown a fuse.
DHW PUMP	If flashing, this indicates either a 'store' thermistor or PCB fault. Refer to the 'is the DHW PUMP indicator flashing' procedure in Section 12.2 (B).
FLOW	If not lit when a hot tap is opened, this indicates either a lack of water flow or possible flow switch problem.
DEMAND	If not lit, this indicates either timer/programmer is not 'calling' for hot water or 'hot water' switch is not set to 'constant'.
BURNER	If flashing, this indicates a PCB fault. Refer to the 'is the burner indicator lit' procedure in Section 12.2 (B).

NOTE: The 'DHW PUMP' indicator may be lit if the boiler is operating to heat the store which has priority over the central heating operation.

There may be a delay before the 'BURNER' indicator is lit when the store is up to temperature.

For further guidance, refer to Section 12.2 (main fault finding procedures).

12.2 MAIN FAULT FINDING PROCEDURES

A NO CENTRAL HEATING - BUT HOT WATER OK

First, set the hot water switch to OFF

Is the 'DEMAND' indicator lit?	NO	Check programmer/timer and room thermostat are calling for heating.
	NO	Checking 'heating' switch is set to 'TIMED'.
Is the 'CH PUMP' indicator lit?	YES PCB is supplying voltage to the CH pump but the pump is not working.	Check electrical connections at the pump. Check for 230V at the pump terminals. Check if CH pump is stuck: <ul style="list-style-type: none"> • Check for rotation of shaft/impellar. • If still not operating, replace the CH pump.
	YES CH pump is not but there is no circulation.	Check both pump valves are open. Check non-return valve on CH pump is operational (not sticking). Check there are no air locks in the system (if removal of air is difficult - see additional check list).
Is the 'CH PUMP' indicator lit?	NO	Check the non-return valve on the CH pump - is it stuck blocked open - check/rectify. NOTE: CH return will be better than flow if CH non-return valve is jammed open. Check by closing one heating pump valve to stop circulation - does the store then come up to temperature? If the problem is not due to CH non-return valve - continue to the next check.
Is the 'CH PUMP' indicator flashing?	YES Fast or slow flash	First, set boiler 'ON/OFF' switch to 'OFF'. Wait 5 seconds Then set 'ON/OFF' switch back to 'ON'.
	Fast flash (twice per second): Indicates a possible fault with the 'flow' thermistor.	Check CH 'flow' thermistor connection to the PCB. Replace 'flow' thermistor.
If the 'CH PUMP' indicator continues flashing?	Slow flash (once every 2 seconds): Indicates a possible fault with the PCB relay.	Replace PCB
	YES	Is the burner firing? If no: refer to 'burner not operating' procedure in Section 12.2 (C).

B NO HOT WATER - BUT CENTRAL HEATING OK

First, set the heating switch to OFF

Is the 'DEMAND' indicator lit?	NO	Check programmer is calling for hot water. If no programmer is fitted: check 'hot water' switch is set to 'CONSTANT'.
	NO	Check 'heating' switch is set to 'TIMED'.
Is the 'FLOW SWITCH' indicator lit?	NO	Check hot water tap is open. Check water flow rate is at least 3 litres/minute.
	Cannot achieve 3 litres/minute	Check the mains stop tap is open fully. Check the cold water isolation valve in the boiler is open. Check if the flow restrictor (located in the cold water isolation valve) is clear. If not, clean restrictor or remove from valve. NOTE: No flow restrictor is fitted to the Combi 36 model.
	Is the water pressure OK? Low water pressure = low water flow rate.	Check standing water pressure. 2 bar minimum standing pressure required. Check running (dynamic) pressure. 1 bar minimum dynamic pressure required.
	If water pressure is OK.	Check for blockage in plate heat exchanger unit. NOTE: In hard water areas, scale will be produced that can block the plate heat exchanger if no anti-scale protection has been installed. Refer to Section 5 for further details.
Is the 'FLOW SWITCH' indicator lit?	Is plate heat exchanger is OK.	Check flow switch is correctly positioned: the arrow (on flow switch body) must point in the direction of flow, i.e. toward the front of boiler. Check switch is free to operate: close cold water isolation valve, remove flow switch from pipework - manually operate switch paddle to check. Remove any debris/blockage from the pipework body or switch paddle. Check for electrical continuity between flow switch terminals when switch is closed. No continuity - replace flow switch. No 230V - check connections at PCB. If still no 230V - replace PCB.
	YES	Flow switch is activated. Continue to the next check.
Is the 'DHW PUMP' indicator lit?	NO	Continue to next check.
Is the 'DHW PUMP' indicator flashing?	YES Fast or slow flash	First, set boiler 'ON/OFF' switch to 'OFF'. Wait 5 seconds. Then set 'ON/OFF' switch back to 'ON'.
	If the 'DHW PUMP' indicator continues flashing.	Fast flash (twice per second): Indicates a possible fault with the 'store' thermistor. Check DHW 'store' thermistor connection to PCB. Replace 'store' thermistor.
Is the 'DHW PUMP' indicator lit?	Slow flash (once every 2 seconds): Indicates a possible fault with the PCB (relay).	Replace PCB.
	YES PCB is supplying voltage to the DHW pump - but pump is not working.	Check for electrical connections at the pump. Check for 230V at the pump terminals. Check if CH pump is stuck: <ul style="list-style-type: none"> • Check for rotation of shaft/impeller. • If still not operating, replace the DHW pump.
	YES DHW pump is working but no circulation.	Check both pump valves are open. Check non-return valve on DHW pump is operational (not sticking). Check there are no air locks in the system (if removal of air is difficult - see additional check list).
Is the 'DHW PUMP' indicator lit?	YES DHW pump is working and water is circulating.	Hot or warm water should be present at hot tap. If not: refer to 'poor hot water' procedure in Section 12.3.
	Is the 'BURNER' indicator lit?	YES
Is the 'BURNER' indicator lit?	YES	Is burner firing? If no: refer to 'burner not operating' procedure in Section 12.2 (C).

C BURNER NOT OPERATING

First, set either hot water or heating to ON

Is the 'BURNER' indicator lit?	NO	Refer to 'initial checklist' for guidance.
	NO	Continue to next check.
Is the 'BURNER' indicator flashing?	YES	First, set boiler 'ON/OFF' switch to 'OFF'.
	Fast or slow flash.	Wait 5 seconds Then set 'ON/OFF' switch back to 'ON'.
If the 'BURNER' indicator continues flashing.	Slow flash	Replace PCB
	(once every 2 seconds): Indicates a possible fault with the PCB (relay).	
Is the 'BURNER' indicator lit?	YES	Check all electrical connections to burner control box.
	PCB is supplying voltage to the burner - but the burner is not working.	Check for 230V at L and N terminals in control box. Is 'lockout' button (on control box) lit? If yes: press 'lockout' button to reset burner. If burner does not fire, refer to Section 12.4 (burner fault finding).

12.3 POOR HOT WATER CHECKLIST

Always check the basics before changing parts.

Burner	If heat energy input is incorrect: heat energy output will be incorrect. Poor heat input = poor hot water.	Check nozzle is correct size. Check oil pump pressure is correct. Check combustion is correctly set.
DHW pump	Plate heat exchanger requires water circulation from primary store to operate.	Check pump speed setting: it must be maximum. Check pump valves are fully open.
Thermistors	DHW 'store' and CH 'flow' thermistors must detect temperatures correctly.	Check both are fully inserted in their pockets.
Water flow rate at hot tap	Excessive flow rate exceeds heat input from burner. Excessive flow rate = poor hot water.	Check flow rate at tap. Combi 21 = 12 litres/minute maximum. Combi 26 = 15 litres/minute maximum. Combi 36 = 18 litres/minute maximum.
Water pressure	Excessive pressure has a major influence on flow rate.	Check standing and operating water pressure. 2 bar minimum standing pressure required. 8 bar maximum standing pressure. If greater than 8 bar; fit a pressure reducing valve on the cold supply to the boiler. 1 bar minimum dynamic pressure required.
Water condition	Scale forming in the plate heat exchanger = poor heat transfer in plate = poor hot water temperature.	Check for scale in the plate heat exchanger. Replace plate heat exchanger if necessary. In hard water areas some form of anti-scale device or water softener must be fitted. NOTE: Faults due to hard water scaling are not covered by the product guarantee.
Thermostatic blending valve	Must be correctly set to provide optimum hot water.	Check if blending valve is scaled up (refer to 'water condition' above). Clean or replace as necessary.

! NOTE !

For an overview of the fault diagnostic capabilities built into the circulating pumps that come installed in all VortexBlue Combi models, please refer to Appendix A2 or A3, as required, at the back of this installation and servicing manual.

12.4 BURNER FAULT INDICATION

Whenever a burner lockout occurs the cause is displayed via the reset push button indicator LED on the control box. The colour, sequence and speed of the indicator LED flashes identify the specific lockout type and the possible causes are listed in Table 12-1.

Table 12-1: Burner fault indication

Lockout description	Lockout time	LED colour	Probable cause
Presence of extraneous light during standby	After 25 seconds	RED blinking	• Presence of a false flame signal before the heat request
Presence of extraneous light detected during pre-purging	After 25 seconds	RED blinking	• Presence of false flame signal during pre-purging
Extraneous light detected during post-purging	After 25 seconds	RED blinking	• Presence of false flame signal during post-purging (or pre-heating if the short-circuit socket is not connected)
The flame is not detected after the safety time	After 5 seconds from oil-valve starts	RED steady ON	• UV sensor defective or dirty • Oil valve defective or dirty • Faulty ignition transformer • Badly regulated burner • Oil fuel not present
Flame failure during operation	After 3 recycles	RED blinking	• Badly adjusted burner • Oil valve defective or dirty • UV sensor defective or dirty
Fan motor error	Immediate (during pre-purge)	RED, ORANGE blinking inverted	• Faulty fan motor • Fan motor not connected
Malfunction in the internal control circuit that drives the oil valve	Immediate (during pre-purge)	RED, GREEN blinking inverted	• Faulty oil valve • Internal control circuit that drives the oil valve faulty
Eeprom error	Immediate (during pre-purge)	ORANGE, GREEN blinking inverted	• Faulty internal memory

12.5 BURNER FAULT DIAGNOSTICS

Table 12-2: Burner faults

Faults	Possible cause	Fault diagnostics	Solutions
The burner does not start when there is heat demand	Lack of electrical supply	OFF	Check presence of voltage in the L - N of the four pin plug Check the conditions of the fuses. Check that safety thermostat is not in lockout
	The UV sensor sees an extraneous light	GREEN, RED blinking	Eliminate the extraneous light.
	The connections in the control box are wrongly inserted	OFF	Check and connect all the plugs and sockets properly.
The burner goes into lockout mode before or during the pre-purging	The UV sensor sees extraneous light	RED blinking	Eliminate the extraneous light.
Burner runs normally in the pre-purge and ignition cycle and locks out after about 5 seconds	The UV sensor is dirty	RED steady ON	Clean it
	The UV sensor is faulty		Replace it
	Flame moves away or fails		Check pressure and output of the fuel
			Check air output
			Change nozzle
	Check the coil of solenoid valve		
Burner starts with an ignition delay	The ignition electrodes are wrongly positioned	GREEN blinking	Adjust them according to the instructions of this manual
	Air output is too high		Set the air output according to the instructions of this manual
	Nozzle dirty or worn		Replace it

12.6 RIELLO RDB BLU FAULT FINDING CHART

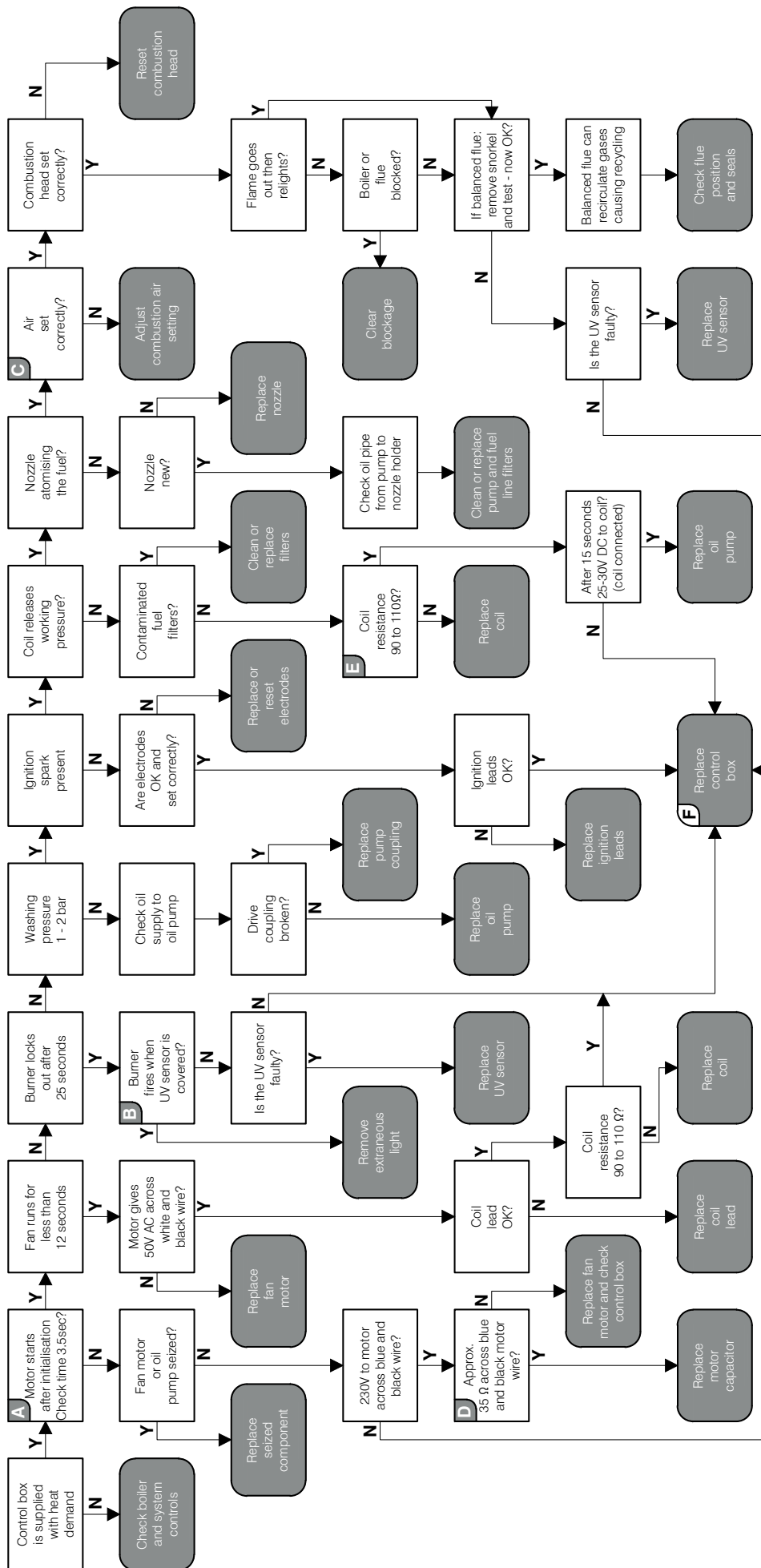

13 SPARE PARTS

13.1 BOILER PARTS LIST

Table 13-1: Boiler parts list

Description	Grant UK product code
Cleaning door nut and washer set	EFBS14
Double pole switch	EFBS19
Baffle set (complete) - Combi 21 & 26	VBS01
Baffle set (complete) - Combi 36	VBS36
Turbulator baffle - 360 mm (single) - all models	VBS05
Combustion Door - Combi 21 and 26	MPCBS110A
Combustion Door - Combi 36	VBS69Z
Cleaning door rope seal - Combi 21 and 26	VBS15
Cleaning door rope seal - Combi 36	VBS16
Limit thermostat (110°C) c/w Earth wire	VBS147
Wilo Yonos Para RKC HE circulating pump (7m head) - all models before November 2019	VBS126
Wilo Para SC HE circulating pump (7m head) - all models from November 2019	VBS159
Temperature Control PCB (c/w sensors) - all models	MPCBS54E
Temperature Control PCB (w/o sensors) - all models	MPCBS96
Direct H/W Sensor for PCB - all models	MPCBS98
Central Heating Sensor for PCB - all models	MPCBS97
Manual Air Vent - all models	MPCBS68
Automatic Air Vent	MPCBS29
Plate Heat Exchanger	MPCBS53A
Thermostatic Mixing Valve	MPCBS22F
Flow Switch - All models	MPCBS71X
Single Pole Low Pressure Switch	MPCBS49X
Non-Return Check Valve (28mm) - all models	MPCBS81B
Pump Valve pair (22mm) - Combi 21 and 26	MPCBS69
Pump Valve pair (28mm) - Combi 36	MPCBS64

13.2 SEALED SYSTEM PARTS LIST

Table 13-2: Sealed system parts list

Description	Grant UK product code
Expansion vessel (24 litre)	VBS124
Water pressure gauge	VBS08
Pressure relief valve (3.0 bar)	MPCBS123
Pressure relief valve with pressure gauge port (3.0 bar)	MPCBS124
Expansion vessel flexible hose - all models	VBS125
Filling Loop Kit (c/w valves)	MPCBS30

13.3 RIELLO RDB BLU BURNERS

This section gives an exploded view of the Riello burners in the Grant VortexBlue boilers, and a parts list associated with them.

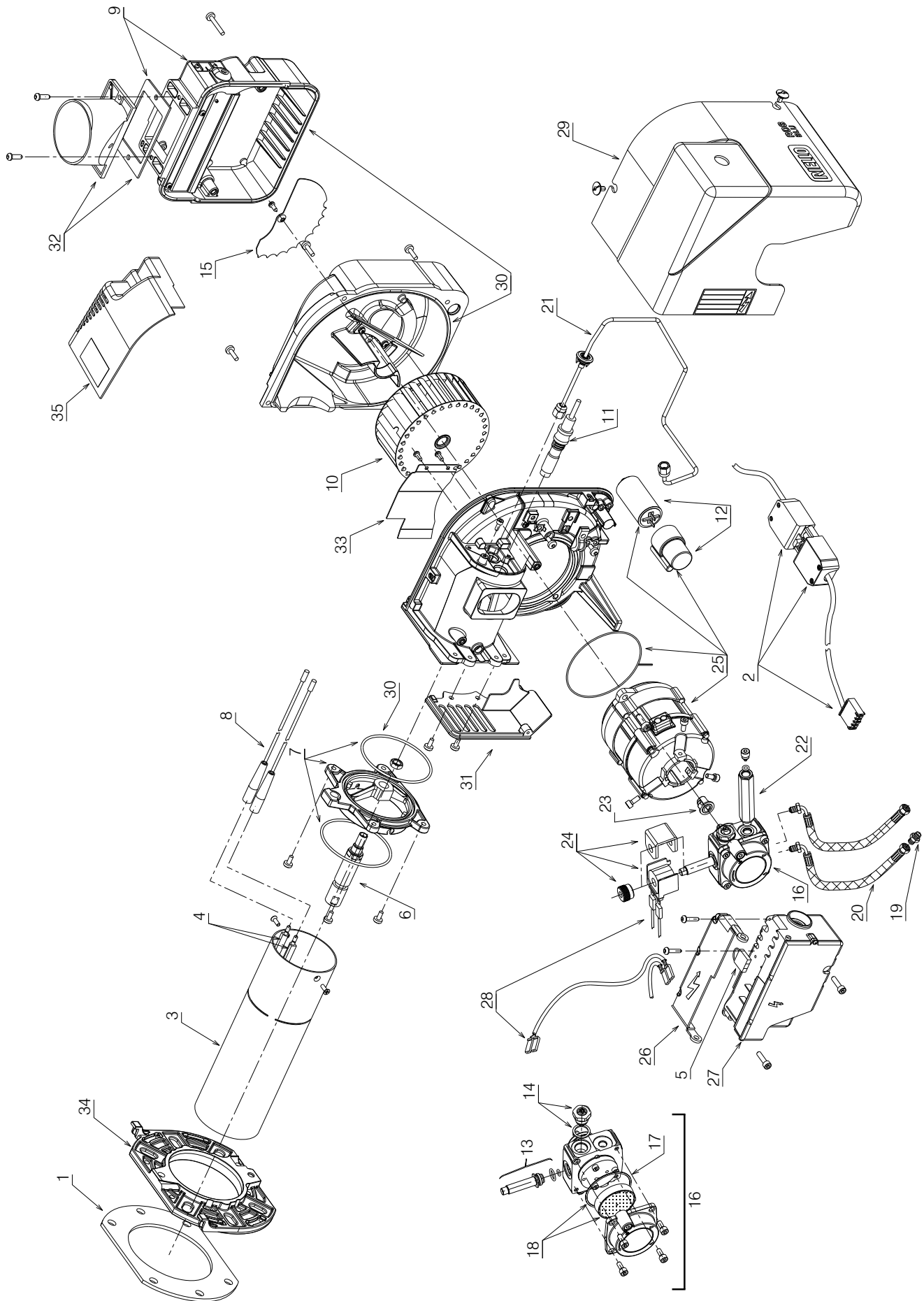

Figure 13-1: Exploded view of Riello RDB BLU burner

Table 13-3: Riello RDB BLU Burner Parts List

Key	Description	VortexBlue Combi 21	VortexBlue Combi 26	VortexBlue Combi 36	Riello product code	Grant UK product code
1	Gasket - refer to item 34	✓	✓	✓	N/A	N/A
2	4-pin connector	✓	N/A	N/A	20117417	Z20117417
	4-pin connector	N/A	✓	✓	20117432	Z20117432
3	Combustion head - BG1	✓	N/A	N/A	20117435	Z20117435
	Combustion head - BG2	N/A	✓	N/A	20120985	Z20120985
	Combustion head - BG3+	N/A	N/A	✓	20133762	Z20133762
4	Ignition electrodes	✓	✓	✓	20117455	Z20117455
5	Pre-heater jumper	✓	✓	✓	20045862	Z20045862
6	Nozzle holder	✓	✓	N/A	20117459	Z20117459
	Nozzle holder	N/A	N/A	✓	20117461	Z20117461
7	Collar (including o-rings)	✓	✓	N/A	20117472	Z20117472
	Collar (including o-rings)	N/A	N/A	✓	20117476	Z20117476
8	Ignition HT lead	✓	✓	✓	20105111	Z20105111
9	Air damper assembly	✓	N/A	N/A	3008647	Z3008647
	Air damper assembly	N/A	✓	✓	3008839	Z3008839
10	Fan	✓	✓	✓	3005788	Z3005788
11	UV sensor	✓	✓	✓	20095126	Z20095126
12	Capacitor 4.5 µF	✓	✓	✓	20071576	Z20071576
13	Solenoid valve	✓	✓	✓	3007871	Z3007871
14	Pump pressure regulator	✓	✓	✓	20032135	Z20032135
15	Air adjuster disc	N/A	N/A	N/A	20094349	Z20094349
16	Oil pump	✓	✓	✓	20030953	Z20030953
17	O-ring (pump filter) - 10 pack	✓	✓	✓	3007175	Z3007175
18	Pump filter and o-ring	✓	✓	✓	3020436	Z3020436
19	Oil hose connector - 3/8 x 1/4	✓	✓	✓	3003602	Z3003602
20	Flexible oil hose	✓	✓	✓	3007621	Z3007621
21	Oil pipe	✓	✓	✓	20117488	Z20117488
22	Pressure gauge connector	✓	✓	✓	3008876	Z3008876
23	Oil pump drive coupling - 10 pack	✓	✓	✓	3000443	Z3000443
24	Solenoid coil	✓	✓	✓	3008648	Z3008648
25	Motor and capacitor 4.5 µF	✓	✓	✓	20071577	Z20071577
26	Control box cover	✓	✓	✓	20094351	Z20094351
27	Control box	✓	✓	✓	20117694	Z20117694
28	Solenoid coil lead	✓	✓	✓	3008682	Z3008682
29	Cover	✓	✓	✓	20117497	Z20117497
30	O-ring kit	✓	✓	✓	3008878	Z3008878
31	Front shield	✓	✓	✓	3020306	Z3020306
32	Air intake - balanced flue	✓	✓	✓	3020281	Z3020281
33	Air baffle	✓	✓	N/A	20117504	Z20117504
33	Air baffle	N/A	N/A	✓	20117506	Z20117506
34	Flange and gasket*	✓	✓	✓	20116712	Z20116712
35	Air intake - conventional flue	N/A	N/A	N/A	20012046	Z20012046

* The flange and gasket are supplied as a combined pack.

14 DECLARATION OF CONFORMITY

EC DECLARATION OF CONFORMITY

In accordance with BS EN ISO/IEC 17050-1:2004

We: Grant Engineering (UK) Limited

Of: Hopton House
Hopton Industrial Estate
Devizes
SN10 2EU

Telephone: +44 (0)1380 736920

Fax: +44 (0)1380 736991

Email: info@grantuk.com

Website: www.grantuk.com

Declare that:

Equipment: Domestic oil boilers

Model Name/Number: Grant VortexBlue Combi 21, 26 and 36

Note: All Grant Combi variants are supplied with glandless high efficiency integrated circulators

In accordance with the following Directives:

2006/95/EEC Conforms with the safety objectives of the Low Voltage Directive and its amending directives.

2004/108/EC Conforms with the essential protection requirements of the Electromagnetic Compatibility Directive and its amending directives.

92/42/EC Conforms with the requirements of the Boiler Efficiency Directive.

2010/30/EU Conforms with the Labeling of Energy related products to EU (no) 811/2013

2009/125/EC Conforms with the Ecodesign of Energy related products to EU (no) 813/2013

I hereby declare that the equipment named above has been tested and found to comply with the relevant sections of the above referenced specifications. The unit complies with all essential requirements of the Directives.

Responsible Person: Neil Sawers

Position: Technical Manager

Signature:



Date: November 2018

15 HEALTH AND SAFETY INFORMATION

Under the Consumer Protection Act 1987 and Section 6 of the Health & Safety at Work Act 1974, we are required to provide information on substances hazardous to health (COSHH Regulations 1988).

Adhesives, sealants and paints used in the manufacture of the product are cured and present no known hazards when used in the manner for which they are intended.

The following other materials are present in the product:

15.1 INSULATION MATERIALS

Material Types:

Ceramic fibre board, mineral wool.

Description:

Rigid board, slabs, sleeves, gaskets, ropes.

Known Hazards:

May cause temporary irritation or rash to skin. High dust levels may irritate eyes and upper respiratory system.

Precautions:

Avoid unnecessary or rough handling, or harsh abrasion of boards. Normal handling and use of material should not produce high dust levels.

Avoid inhalation, and contact with skin and eyes.

After handling always follow normal good hygiene practices.

Protection:

Use disposable gloves, face mask and eye protection.

First Aid:

Eyes - If irritation occurs, wash eyes with copious amounts of water.

If symptoms persist, seek immediate medical advice.

Skin

If irritation occurs, wash under running water before washing with soap and water.

Inhalation

Remove to fresh air, drink water to clear throat and blow nose to remove dust/fibres.

Ingestion

Drink plenty of water.

15.2 SEALANT AND ADHESIVE

Material Types:

Silicone elastomer.

Description:

Sealant and adhesive.

Known Hazards:

Irritation to eyes.

Precautions:

Avoid inhalation of vapour, contact with eyes and prolonged or repeated contact with skin.

After handling always follow normal good hygiene practices.

Protection:

Use eye protection. Rubber or plastic gloves should be worn where repeated contact occurs and a face mask worn when working in confined spaces.

First Aid:

Eyes

Flush eyes with water for 15 minutes. Seek immediate medical attention.

Skin

Wipe off and wash with soap and water.

Inhalation

Remove to fresh air.

15.3 KEROSENE AND GAS OIL FUELS (MINERAL OILS)

Known Hazards:

The effect of mineral oils on the skin vary according to the duration of exposure and the type of oil.

The lighter fractions remove the protective grease naturally present on the skin, leaving it dry, liable to crack and more prone to damage by cuts, abrasions and irritant chemicals.

Skin rashes (Oil acne) most often on arms, but also on any part of the body in contact with oil or oily clothing.

Contact with fuel oils can cause dermatitis.

Precautions:

Avoid as far as possible any skin contact with mineral oil or with clothing contaminated with mineral oil.

The use of a lanolin-based barrier cream is recommended, in conjunction with regular washing with soap and rinsing with water to ensure all oil is removed from the skin.

Take care to prevent clothing, especially underwear, from becoming contaminated with oil.

Do not put oily rags or tools in pockets, especially trouser pockets.

Have first-aid treatment at once for an injury, however slight.

Do not inhale any vapours from mineral oils.

16 END OF LIFE INFORMATION

GENERAL

Grant oil boilers incorporate components manufactured from a variety of different materials. The majority of these materials can be recycled whilst the smaller remainder cannot.

Materials that cannot be recycled must be disposed of according to local regulations using appropriate waste collection and/or disposal services.

DISASSEMBLY

There is little risk to those involved in the disassembly of this product. Please refer to and follow the Health and Safety Information given in the Installation & Servicing Instructions provided with the boiler.

For guidance on the disassembly of the boiler refer to the information given in the Servicing section of the Installation & Servicing Instructions provided with the boiler.

RECYCLING

Many of the materials used in Grant oil boilers can be recycled, these are listed in the table below:

COMPONENT	MATERIAL
Outer casing panels	Mild steel (polyester powder coated)
Primary heat exchanger and baffles	Mild steel
Secondary heat exchanger	Stainless steel
Secondary heat exchanger spirals	Aluminium alloy
Pipework	Copper
Burner body/flange	Aluminium alloy
Burner oil pump	Aluminium alloy/steel
Riello oil burner cover	Plastic
Electrical wiring	Copper/plastic
Thermostats	Copper/plastic
Printed Circuit boards	Copper/plastic

DISPOSAL

All materials other than those listed above must be disposed of responsibly as general waste.



Neil Sawers
Technical Manager

17 PRODUCT FICHE

Product fiche concerning the
 COMMISSION DELEGATED REGULATIONS
 (EU) No 811/2013 of 18 February 2013
 (EU) No 813/2013 of 2 August 2013

VortexBlue Internal Combi	Symbols	Unit	Combi 21	Combi 26	Combi 36
Condensing boiler			Yes	Yes	Yes
Low temperature boiler			No	No	No
B1 boiler			No	No	No
Combination heater			Yes	Yes	Yes
Rated heat output	Prated	kW	21	26	36
Useful heat output					
At rated heat output and high temperature regime	P_4	kW	21	26	36
At 30% of rated heat output and low temperature regime	P_1	kW	6.3	7.8	10.8
Auxiliary electricity consumption					
At full load	elmax	kW	0.13	0.13	0.15
At part load	elmin	kW	0.052	0.052	0.039
In standby mode	P_{SB}	kW	0.009	0.009	0.009
Declared load profile			XL	XL	XL
Daily electricity consumption	Q_{elec}	kWh	0.23	0.23	0.205
Annual electricity consumption	AEC	kWh	50.5	50.5	45.2
Useful efficiency					
Seasonal space heating energy efficiency	η_s	%	91.71	91.71	94.56
At rated heat output and high temperature regime	η_4	%	93.6	93.6	95.1
At 30% of rated heat output and low temperature regime	η_1	%	96.4	96.4	99.3
Other items					
Standby heat loss	P_{stby}	kW	0.264	0.264	0.522
Ignition burner power consumption	P_{ign}	kW	0	0	0
Annual energy consumption	Q_{HE}	kWh	-	-	-
Sound power level indoors	L_{WA}	dB	51	51	54
Emissions of nitrogen oxides	NO_x	mg / kWh	73	73	74
Emission class			2	2	2
Water heating efficiency	η_{wh}	%	62.6	62.6	60.38
Daily fuel consumption	Q_{fuel}	kWh	27.2	30	31.1
Annual fuel consumption	AFC	GJ	21.556	26.673	24.67

18 GUARANTEE

You are now the proud owner of a Grant Vortex condensing boiler from Grant Engineering (UK) Limited which has been designed to give years of reliable, trouble free operation.

Grant Engineering (UK) Limited guarantees the manufacture of the boiler including all electrical and mechanical components for a period of **twelve months from the date of installation**⁴, provided that the boiler has been installed in full accordance with the installation and servicing instructions issued.

This will be extended to a total period of **two years** if the boiler is registered with Grant Engineering (UK) Limited within **thirty days of installation** and it is serviced at twelve month intervals³. See main Terms and Conditions below.

Registering the product with Grant Engineering (UK) Limited

Please register your Grant Vortex condensing boiler with Grant Engineering UK Limited **within thirty days of installation**. To do so visit:

www.grantuk.com/support/product-registration

You can register your boiler for a further **twelve months** guarantee (giving **two years** from the date of installation⁴). This does not affect your statutory rights¹.

If a fault or defect occurs within the manufacturer's guarantee period

If your boiler should fail within the guarantee period, you must contact Grant Engineering (UK) Limited who will arrange for the repair under the terms of the guarantee, providing that the boiler has been correctly installed, commissioned and serviced (if the appliance has been installed for more than twelve months) by a competent person and the fault is not due to tampering, running out of oil, oil contamination, debris, system water contamination, misuse, trapped air or the failure of any external components not supplied by Grant Engineering (UK) Limited, e.g. fire valve, motorised valve, etc.

This two year guarantee only applies if the boiler is registered with Grant Engineering (UK) Limited within thirty days of installation⁴ and is serviced after twelve months³.

In the first instance

Contact your installer or commissioning engineer to ensure that the fault does not lie with the system components or any incorrect setting of the system controls that falls outside of the manufacturer's guarantee otherwise a service charge could result. Grant Engineering (UK) Limited will not be liable for any charges arising from this process.

If a fault covered by the manufacturer's guarantee is found

Ask your installer to contact Grant Engineering (UK) Limited Service Department on +44 (0)1380 736920 who will arrange for a competent service engineer to rectify the fault.

Remember - before you contact Grant Engineering (UK) Limited

- Ensure the boiler has been installed, commissioned and serviced by a competent person in accordance with the installation and servicing instructions.
- Ensure there is oil to supply the burner.
- Ensure the problem is not being caused by the heating system or its controls. Consult the boiler handbook for guidance.

Free of charge repairs

During the **two year** guarantee period no charge for parts or labour will be made provided that the boiler has been installed and commissioned correctly in accordance with the manufacturer's installation and servicing instructions, it was registered with Grant Engineering (UK) Limited within thirty days of installation⁴ and, for boilers over twelve months old, details of annual service is available³.

The following documents must be made available to Grant Engineering (UK) Limited on request:

- Proof of purchase
- CD10 Installation Completion Form (or equivalent document)
- CD11 Commissioning Report Form (or equivalent document)
- Service documents (CD11 or equivalent document)

Chargeable repairs

A charge may be made (if necessary following testing of parts) if the breakdown is due to any fault(s) caused by the plumbing or heating system, e.g. contamination of parts due to system contamination, sludge, scale, debris or trapped air. Refer to 'Extent of manufacturer's guarantee'.

Extent of manufacturer's guarantee

The manufacturer's guarantee does NOT cover the following:

- If the boiler has been installed for over **two years**.
- If the boiler has not been installed, commissioned, or serviced by a competent person in accordance with the installation and servicing instructions.
- Instances where the serial number has been removed or made illegible.
- Fault(s) due to accidental damage, tampering, unauthorised adjustment, neglect, misuse or operating the boiler contrary to the manufacturer's installation and servicing instructions.
- Damage due to external causes such as bad weather conditions (flood, storms, lightning, frost, snow, or ice), fire, explosion, accident or theft.
- Fault(s) due to incorrectly sized expansion vessel(s), incorrect vessel charge pressure or inadequate expansion on the system.
- Fault(s) caused by external electrics and external components not supplied by Grant Engineering (UK) Limited.
- Problems caused by lack of oil or faults with the oil storage and supply system.
- Fault(s) due to contamination of the oil storage and supply system, e.g. water or debris.
- Bleeding or removing oil storage tank contamination or blockages from oil lines.
- Problems due to the flue system being incorrectly fitted or not installed to meet installation requirements.
- Boiler servicing, de-scaling or flushing.
- Cleaning out condensate traps/discharge pipes or thawing out frozen condensate pipework.
- Checking and replenishing system pressure.
- Oil supply pipelines, electrical cables and plugs, external controls not supplied by Grant Engineering (UK) Limited.
- Heating system components, such as radiators, pipes, fittings, pumps and valves not supplied by Grant Engineering (UK) Limited.
- Instances where the oil boiler has been un-installed and re-installed in another location.
- Use of spare parts not authorised by Grant Engineering (UK) Limited.
- Consumable items including, but not limited to, oil nozzles, oil hoses, gaskets and seals.

IMPORTANT

The nozzle and braided oil hose supplied with the boiler are only covered for the period up to the time of the first service (twelve months). Both **must** be changed on the first service and on every annual service thereafter.

IMPORTANT

A suitable oil filter with a minimum 15µ filtration **must** be installed in the oil supply line.

Do not wait until the fuel supply runs out before you re-order. Sludge in the bottom of the tank may be drawn into the fuel lines. It is recommended that the boiler is switched off when the new oil supply is delivered and that the fuel is allowed to settle for an hour before restarting the boiler.

Terms of manufacturer's guarantee

- The Company shall mean Grant Engineering (UK) Limited.
- The boiler must be installed by a competent person and in full accordance with the relevant Codes of Practice, Regulations and Legislation in force at the time of installation.
- The boiler is guaranteed for **two years** from the date of installation⁴, providing that every twelve months the annual service has been completed³ and the boiler registered with the Company within thirty days of installation. Any work undertaken must be authorised by the Company and carried out by a competent service engineer.
- This guarantee will be invalid if the boiler does not have an annual (every twelve month) service and will then be limited to twelve months from the date of installation⁴.
- The shell (heat exchanger) of the oil boiler is covered by a **five year parts and labour** guarantee from the date of installation⁴. This is subject to the following:
 - The boiler is operated correctly, in accordance with the Installation and servicing instructions.
 - Grant Engineering (UK) Limited **strongly recommends** that a Grant Mag-One in-line magnetic filter/s (or equivalent⁵) is fitted in the heating system pipework. This should be installed and regularly serviced in accordance with the filter manufacturer's instructions. We reserve the right to ask for proof of installation – failure to provide this may result in the guarantee becoming invalid.
 - Proof is provided that the system has been flushed or chemically cleaned where appropriate (refer to BS 7593) and that the required quantity of a suitable corrosion inhibitor added.
 - Proof of annual servicing (including the checking of any expansion vessels and pressure relief valves) must be provided if and when requested by the Company.
- This guarantee does not cover breakdowns caused by incorrect installation, neglect, misuse, accident or failure to operate the boiler in accordance with the manufacturer's installation and servicing instructions.
- The boiler is registered with the Company within thirty days of installation. Failure to do so does not affect your statutory rights¹.
- The balance of the guarantee is transferable providing the installation is serviced prior to the dwelling's new owners taking up residence. Grant Engineering (UK) Limited must be informed of the new owner's details.
- The Company will endeavour to provide prompt service in the unlikely event of a problem occurring, but cannot be held responsible for any consequences of delay however caused.
- This guarantee applies to Grant Engineering (UK) Limited boilers purchased and installed on the UK mainland, Isle of Wight, Channel Islands, Isle of Man and Scottish Isles only². Provision of in-guarantee cover elsewhere in the UK is subject to agreement with the Company.
- All claims under this guarantee must be made to the Company prior to any work being undertaken. Invoices for call out/repair work by any third party will not be accepted unless previously authorised by the Company.
- Proof of purchase and date of installation, commissioning and service documents must be provided on request.
- If a replacement boiler is supplied under the guarantee (due to a manufacturing fault) the product guarantee continues

from the installation date of the original boiler and **not** from the installation date of the replacement⁴.

- The oil boiler must be connected to a mains water supply (installations utilising a private water supply are not covered by this guarantee).
- Breakdown/failure due to lime scale will not be covered by this guarantee.
- The replacement of a boiler under this guarantee does not include any consequential costs, such as the removal or replacement of worktops, kitchen units, etc.
- The boiler (excluding external modules) must not be sited in a location where it may be subjected to frost.

Hard water advice (for Combi boilers only)

If you live in a hard water area, protection against scaling must be given to the domestic hot water heat exchanger of your combination boiler.

You should fit an appropriate scale inhibitor or water softener as any breakdown caused by water scaling is not covered by the manufacturer's guarantee. Ask your installer for advice.

Foot notes

1. Your statutory rights entitle you to a one year guarantee period only.
2. The UK mainland consists of England, Scotland and Wales only. Please note that for the purposes of this definition, Northern Ireland and Scilly Isles are **not** considered part of the UK mainland.
3. We recommend that your oil boiler is serviced every twelve months (even when the guarantee has expired) to prolong the lifespan and ensure it is operating safely and efficiently.
4. The guarantee period will commence from the date of installation, unless the installation date is more than six months from the date of purchase, in which case the guarantee period will commence six months from the date of purchase.
5. As measured by gauss. The MagOne magnetic filter has a gauss measurement of 12,000.

Version 1.2 – February 2017

APPENDIX A1

RDB BLU BURNER INFORMATION

A1.1 GENERAL

! WARNING !

The burner and flange are matched.
 If the burner is changed, the correct flange for the replacement burner **MUST** be fitted.
 Refer to Section 13 (Spare Parts).

All Grant VortexBlue boilers are fitted with a Riello RDB BLU blue flame burner. This has been designed to operate with reduced NOx emissions that meet the European Ecodesign emissions regulations.

From September 2018 the maximum permissible NOx level for oil fired boilers is 120mg/kWh. All Grant VortexBlue boilers, fitted with the Riello RDB BLU burner, will operate well below this minimum level and thus fully comply with these emissions regulations when they come into effect.

A1.2 BURNER FEATURES

The Riello RDB BLU blue flame burner fitted to the Grant VortexBlue boilers is very similar to the Riello RDB 'yellow flame' burners, such as those fitted to the Vortex range of oil fired boilers.

The main differences with the blue flame burner are as follows:

- An Ultra Violet (UV) sensor is used - the blue flame cannot be detected by the usual photocell.
- A digital control box is used - the UV cell cannot be used with the usual "analogue" control box.
- A clear reset button (on the control box) with burner status and fault identification by the use of different coloured indicator lights.
- A longer combustion head – to allow the necessary recirculation of the combustion gases.
- A post purge following flame shut off – requiring a permanent live to the burner in addition to the usual switched live.

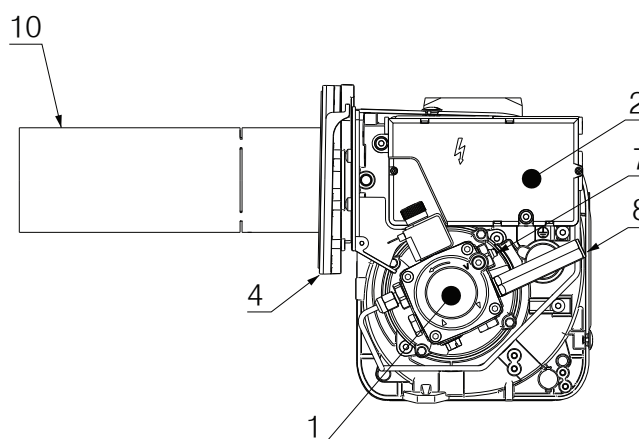
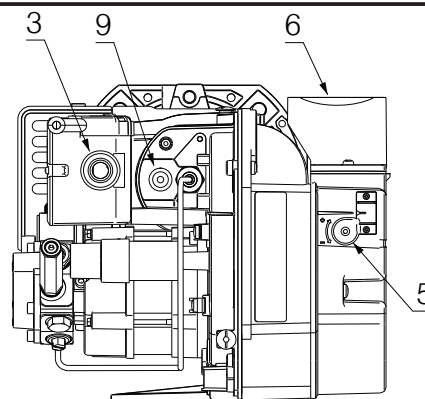

Figure A1-1: Burner components

Table A1-1: Burner components key

Key	Description
1	Oil pump
2	Digital control box
3	Reset push-button with lockout lamp
4	Flange with insulating gasket
5	Air damper adjustment screw
6	Snorkel (balanced flue)
7	Pump pressure adjustment screw
8	Pressure gauge port
9	UV sensor
10	Combustion head

A1.3 DIGITAL CONTROL BOX

The digital control box fitted to this burner has several different features compared to the more commonly used 'analogue' control box.

A1.3.1 Reset Push-button

This is a clear (transparent) button that will indicate the operating status of the burner and also burner faults depending on the colour of the indicator LED visible through the reset button.

If there is no heat demand to fire the burner, the indicator LED will be off, i.e. no colour visible through the reset push button.

Refer to Figure A1-1 for the location of the control box and reset push-button.

If the reset push-button LED is indicating a lockout (refer to Section A1.3.3), press the reset button to attempt to re-start the burner. If the burner then operates correctly the lockout may have been caused by a temporary fault that has now cleared. If the lockout persists the cause of the fault should be diagnosed and rectified.

! NOTE !

To operate the reset push-button it must be pressed in and briefly held (for at least one second) before releasing.

! NOTE !

The burner can only be reset 5 times consecutively, after which the mains power supply has to be switched off and then back on for a further 5 reset attempts to be available.

A1.3.2 Operating Status Indication

From start up the operating status of the burner is displayed via the reset push-button indicator LED on the control box. Refer to Table A1-2.

A1.3.3 Burner Fault Indication

Whenever a burner lockout occurs the cause is displayed via the reset push-button indicator LED on the control box. Refer to Table A1-3.

A1.3.4 Last Lockout Display

The control box memorises the details of the last lockout that occurred and this information can be recalled and displayed by the reset push-button indicator LED.

To operate this function:

- Press and hold the reset push-button for 25 seconds.
- During this time the reset push button indicator LED will first flash RED (twice) and then flash GREEN (once) and then GREEN again (three times).
- As soon as it flashes GREEN four times release the reset push-button immediately.
- The reset push-button indicator LED will then display the last lockout indication, e.g. constant red.
- Refer to the Fault Diagnostics table in Section 12.4 of this installation manual to identify the fault from the indicator LED sequence.

The lockout fault will only be displayed for a period of 10 seconds. If required, this period can be extended by re-pressing the reset push-button during the display of the lockout. The lockout display will then be extended by a further 10 seconds.

Table A1-2: Burner operating status indicator

Status	Reset push-button colour	Seconds		Notes
OFF	OFF	-	-	
Pre-purge	ORANGE blinking	0.5	0.5	
Safety time	GREEN blinking	0.5	0.5	
Normal operating position	GREEN	-	-	Steady ON

Table A1-3: Burner operating status indicator

Status	Reset push-button colour	Seconds		Notes
Extraneous light (false flame signal)	GREEN, RED blinking alternately	0.5	0.5	
Frequency supply error	ORANGE	-	-	Steady ON
Voltage monitor error	ORANGE, GREEN fast blinking alternately	0.2	0.2	
Reset push-button / remote reset anomaly	GREEN, RED fast blinking alternately	0.2	0.2	
Lockout for no flame after safety time	RED	-	-	Steady ON Go to box A*
Lockout for false flame signal	RED blinking	0.5	0.5	Go to box B*
Lockout for maximum number of re-cycles	RED fast blinking	0.2	0.2	Go to box C*
Lockout for fan motor error	RED, ORANGE blinking inverted	2.5	0.5	Go to box D*
Lockout for oil valve error	RED, GREEN blinking inverted	2.5	0.5	Go to box E*
Lockout for eeprom error	ORANGE, GREEN blinking alternately	0.5	0.5	Go to box F*

* Refer to the fault finding chart - Section 12.4.

A1.3.5 Removal of Control Box

! WARNING !

Before removing the control box from the burner, or opening the control box cover, isolate the electrical supply to the boiler.

To remove the control box proceed as follows (referring to Figure A1-2):

- Unscrew and remove screw (1) and open control box cover (2).
- Disconnect all plugs from the control box terminals.
- Unscrew the retaining finger nut and remove the solenoid coil (3) from the oil pump.
- Unscrew and remove the two screws (4) and remove the control box from the burner.
- Disconnect the two ignition leads from the ignition connections on rear of control box.
- Refit the control box to the burner using the reverse of the above procedure.

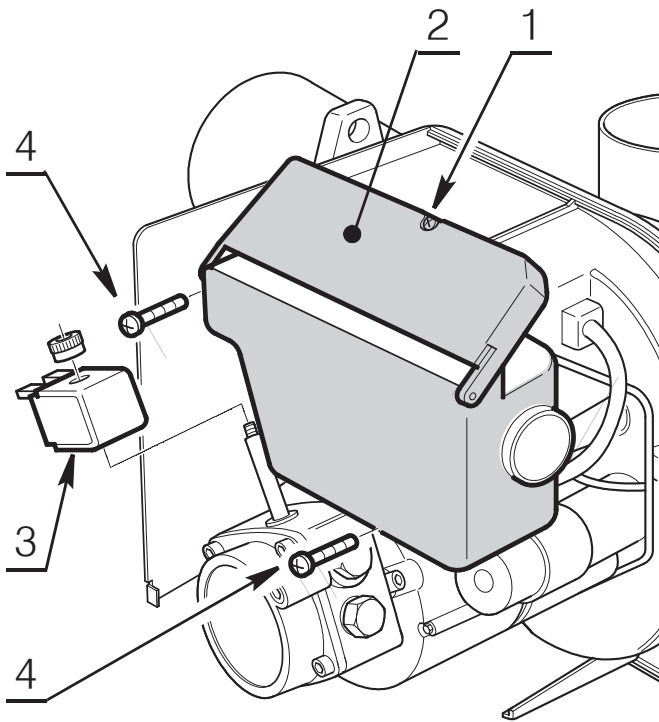

Figure A1-2: Removal of control box

A1.4 BURNER OPERATION

A1.4.1 Burner Operating Times

Table A1-4: Burner operating times

Symbol	Description	Value (seconds)
t0	Standby: the burner is waiting for a heat request	-
t1	Standby time for an input signal: reaction time, control box remains in waiting status for t1	≤ 1
t2	Initialisation standby time: check time following the main power start-up	3.5
t2l	Checks extraneous light during t2: waiting mode for t2l, then lockout: the motor does not start	25
t3	Pre-purge time: the fan motor is working	15
t3l	Checks extraneous light during pre-purging: control box goes into lockout at the end of t3l	25
t3i	Spark pre-ignition time	2
ts	Safety time	5
t4i	Total spark ignition time	10
t4l	Reaction time to achieve safety shut-down due to flame failure	≤ 1
t5i	Spark post-ignition time	3
tr	Re-cycles: Max. no. 3 repetitions of complete start-up sequence if there is a flame failure during operation; the final action at the last attempt following flame failure is a lock-out	3 re-cycles
tpp	Post-purge time: additional purge time at the end of a heat request. Can be interrupted by a new heat request	60

A1.4.2 Presence of Extraneous light or Flame

On burner start up, when the fan starts to pre-purge the burner/boiler, if an extraneous light or flame is detected in the combustion chamber by the UV sensor the burner fan continues to run until either:

- a) The extraneous light or flame disappears, or
- b) 25 seconds elapses, a burner lockout occurs and the fault indicator LED flashes Green/Red if an extraneous light or flame is detected after the fan has started (i.e. at some time during the pre-purge period) the pre-purge time of 15 seconds is reset, and the 25 second time for checking for the presence of extraneous light or flame starts and the fan continues to run.

As above, if the extraneous light or flame does not disappear after 25 seconds a burner lockout occurs. This function is cumulative and can operate a maximum of two times during the burner pre-purge period.

If the extraneous light or flame disappears after 24 seconds (or less) the pre-purge period and the 25 second countdown for checking for extraneous light or flame re-starts. If the extraneous light or flame re-appears the process is repeated. If the extraneous light or flame appears for a third time, the burner goes into lockout.

If during a burner recycle operation due to Flame failure (refer to Section A1.4.4 – Burner Recycle Function) an extraneous light or flame is detected, the 25 second countdown starts for checking for extraneous light or flame.

The presence of extraneous light or flame can also be detected when the burner is in:

- a) The standby condition waiting for a heating demand to start the burner.
- b) The Initialisation period (t2) after the heating demand but before the burner fan starts.

A1.4.3 Spark Ignition Duration

The 'pre-ignition' spark time starts 2 seconds before the oil valve opens (the start of the 5 second 'safety time' period).

The 'post-ignition' spark time ends 3 seconds after the end of the safety time period, i.e. 8 seconds after the oil valve opens.

The ignition spark is present throughout the 'safety time' period (5 seconds) making a total spark ignition period of 10 seconds.

! NOTE !

In the case of continuous ignition sequence recycling after flame failure, or heat demands close to one another, the maximum number of cycle repetitions of the ignition transformer is one attempt every minute.

A1.4.4 Burner Recycle Function

In event of flame failure during burner operation the control box will allow the burner to recycle and repeat the start-up sequence for the burner to attempt to re-fire. This can occur up to a total of three attempts to re-fire the burner. If it fails a fourth time in operation it will cause a burner lockout and the reset push-button indicator LED will be RED.

! NOTE !

After 8½ minutes of continuous burner operation the control box regains one attempt to re-fire (should it be required).

If the power supply to the boiler is disconnected and then reconnected, when the next heat demand is applied to the burner all three possible attempts to re-fire are restored.

A1.4.5 Burner Lockout

In the event of a burner lockout:

If the reset button is pressed four times in succession, without the burner being restarted, pressing the reset a fifth time will 'lock' the reset button. The reset button will flash red and will not respond to being pressed, i.e. it will no longer operate to attempt to restart the burner. This is intended to stop the burner reset from being repeatedly pressed and does not necessarily indicate a fault with the control box.

If this condition occurs, switch the boiler ON/OFF switch (located on the boiler control panel) to OFF. Wait for 5 seconds and then switch it back to ON. The burner reset button should now function as expected.

Before continuing to press the reset button, the cause of the original burner lockout, e.g. lack of fuel, no ignition, etc. must be identified and rectified.

A1.4.6 Post Purge Function

This function allows air flow through the burner for a pre-set time after the burner flame is switched off (on the loss of demand for the burner to fire).

The loss of demand from either the heating system controls, or boiler temperature control, interrupts the switched live to the burner resulting in the fuel supply being shut off and the flame stopped. The permanent supply to the burner maintains the fan operation for a short period to provide the post purging of the burner and boiler prior to the burner re-firing again.

The post-purge function does not operate:

- a) After a burner lockout has occurred
 - b) If the heat demand is interrupted during the pre-purge period.
- However, the post-purge function will operate if the heat demand is interrupted:
- c) During the safety time period (i.e. immediately after burner ignition)
 - d) During normal operation of the burner

If the UV cell detects any extraneous light or flame during the pre-purge period the burner will go to 'lockout' after 25 seconds.

If there is a new heat demand during the post-purge period, the post-purge function is halted (the fan stops) and a new burner operating cycle starts.

APPENDIX A2 WILO YONOS PARA RS RKC CIRCULATING PUMP

A2.1 WILO YONOS PARA RS RKC CIRCULATING PUMP

A2.1.1 PUMP SPECIFICATION

Table A2-1: Pump specification

Make and model	Wilо Yonos PARA RS 15/7.0 RKC FS 130 12
Construction	
Pump housing	Cast iron (with cataphorisis treatment)
Impellar	PP composite with GF 40%
Pump shaft	Stainless Steel
Bearing	Carbon, metal impregnated
Protection Class	IPx4D
Insulation Class	F
Motor Protection	Integrated
Performance	
Max. delivery head	7.2m @ Q = 0 m ³ /h
Max. volume flow	3.3 0 m ³ /h
Minimum suction head @ 50/95°C	0.5/4.5m
Power consumption @ 1 - 230V	3-45W
Nominal Motor Power	37W
Current @ 1 - 230V	0.028 - 0.44 A
Energy Efficiency Index (EEI)	≤ 0.20
Speed	800-4650 rpm
Settings	ΔP-variable (1-7m head) and Constant Speed (I, II and III)
Application	
Maximum Static Pressure	PN6
Temperature range @ maximum ambient temperatures	Maximum ambient temperature 57°C: 0 to 95°C
	Maximum ambient temperature 59°C: 0 to 90°C
	Maximum ambient temperature 67°C: 0 to 70°C
Approved Fluids	Heating Water Water/Glycol - Max 1:1 (above 20% check pumping data)

A2.1.2 PUMP CONTROL PANEL

Wilо Yonos PARA RKC circulating pumps have two possible setting modes:

- Constant speed with three pump speed settings (I, II and III)
- Variable pressure (Δp-v) with pump head adjustable between 1 and 7m head

Figure A2-1 shows the pump control panel with the red selector knob.

Constant Speed Mode (I, II, III)

This is the default setting of the pump and as such is recommended by Grant for heating systems. In this mode the pump speed is not automatically regulated (as with the Variable Pressure Mode), but operates constantly at one of the three possible speeds (set using the red selector knob on the pump control panel).

Variable Pressure Mode (Δp-v)

In this mode the electronic control changes the differential pressure setpoint to be maintained by the pump in a linear fashion between Hs (the value set using the red selector knob on the pump control panel) and ½ Hs. The differential setpoint varies linearly with the volume flow Q.

A2.1.3 INDICATOR LED

The pump is fitted with an indicator LED. This is located around the circumference of the red selector knob. See Figure A2-1 below. This indicates the operating status of the pump and will be illuminated green when the pump is operating normally. This indicator LED can assist in diagnosing and rectifying faults. Refer to Section A2.2.

A2.1.4 SETTING THE PUMP CONTROL MODE

Set the pump to one of the two operating modes as follows:

Constant Speed Mode (I, II, III)

Grant recommends this operating mode for the pump.

To set the pump to the 'Constant Speed' mode, the pointer on the red selector knob must be set to the RIGHT of the mid position. Refer to Figure A2-1.

Set it to point at the required speed setting, I, II or III as required, ensuring that there is adequate flow to distribute the heat from the boiler whilst avoiding high water velocities causing noise in the pipework.

Variable Pressure Mode (Δp-v)

To set the pump to the 'Variable Pressure' mode the pointer on the red selector knob must be set to the LEFT of the mid position. Refer to Figure A2-1.

The further anticlockwise it is set the greater the pressure head setting of the pump – from 1m to 7m head.

If this mode is to be used, set the selector knob at a pressure that represents the maximum pressure (head) loss for the heating system in question.

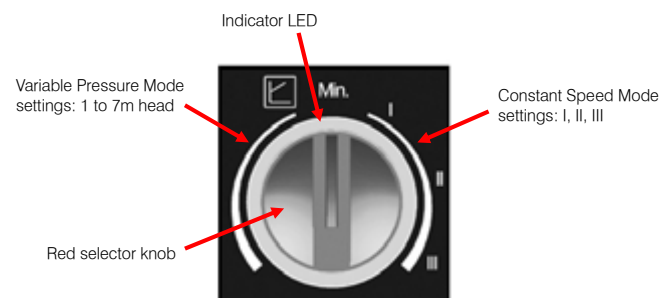

Figure A2-1: Pump control panel with red selector knob and LED indicator

! NOTE !

Both circulating pumps on all Grant Vortex Combi boilers come factory set at Constant Speed Mode III and should be left set on this setting.

The heating circuit circulating pump should be set by the installer to suit the system.

A2.2 CIRCULATING PUMP FAULT DIAGNOSIS - WILO YONOS PARA RS RKC

The indicator LED, located around the circumference of the red control knob can assist in diagnosing and rectifying a fault with the pump. See the table below:

Table A2-2: Pump fault diagnosis

LED condition	Meaning	Diagnostic	Cause	Remedy
Green	Pump operating	Pump runs according to the red knob setting	Normal operation	N/A
Flashes red and green	Pump is operating but stopped	Pump restarts itself after fault has disappeared	Undervoltage Voltage <160V OR Overvoltage Voltage >253V	Check supply voltage is 195V<V<253V
			Overheating: temperature inside motor too high	Check water and ambient temperature
Flashes red	Pump not operating	Pump stopped (blocked)	Pump does not restart itself due to a permanent failure	Replace pump
LED off	No power supply	No voltage to pump control electronics	Pump is not connected to power supply	Check cable connection
			LED is damaged	Check if pump is running
			Electronics are damaged	Replace pump

APPENDIX A3 WILO-PARA 25-130/7-50/SC-6#GRA CIRCULATING PUMP

A3.1 WILO-PARA 25-130/7-50/SC-6#GRA CIRCULATING PUMP

A3.1.1 PUMP SPECIFICATION

Table A3-1: Pump specification

Make and model	Wilo - PARA 25-130/7- 50/SC-6#GRA
Construction	
Pump housing	Cast iron (with cataphoresis treatment)
Impellar	PP composite with GF 40%
Pump shaft	Stainless Steel
Bearing	Carbon, metal impregnated
Motor Data	
Speed	2580 - 4700rpm
Power consumption @ 1 - 230V	8.2 - 50W
Current @ 1 - 230V	0.07 - 0.43A
Minimum starting voltage	170V
Minimum running voltage	160V
Peak inrush current	>3A
Starting torque	>25N.cm
Electrical	
Mains connection	1ph 230V AC +10%/-15% 50/60Hz
Protection Class	IPx4D
Insulation Class	F
Motor Protection	Integrated
Performance	
Max. delivery head	7.7m @ Q = 0 m ³ /h
Max. volume flow	3.5 m ³ /h
Minimum suction head @ 50/95°C	0.5/4.5m
Energy Efficiency Index (EEI)	≤ 0.20
Settings	ΔP-variable (1-7m head) ΔP-constant (1-7m head) Constant Speed (I, II and III)
Application	
Maximum Static Pressure	PN10
Fluid Temperature range @ maximum ambient temperatures (See Section A3.1.2)	Maximum ambient temperature 58°C: 0 to 100°C Maximum ambient temperature 62°C: 0 to 90°C Maximum ambient temperature 66°C: 0 to 80°C Maximum ambient temperature 71°C: 0 to 70°C
Approved Fluids	Heating Water Water/Glycol - Max 1:1 (above 20% check pumping data)

A3.1.2 THERMAL PROTECTION FUNCTION

The pump is equipped with a thermal self-protection mode.

If the fluid temperature exceeds the maximum value at a specific ambient temperature, e.g. 90°C at an ambient of 62°C, the pump will automatically reduce the power consumption, reducing the speed and performance of the pump.

In this condition the Run/Fault signal LED will be blinking RED. When normal temperature conditions return the pump will automatically revert to normal operation.

If the fluid temperature increases further, the thermal protection function may stop the pump temporarily.

In this condition the Run/Fault signal LED on the pump will be constant RED until normal temperature conditions return.

A3.1.3 PUMP COMPONENTS

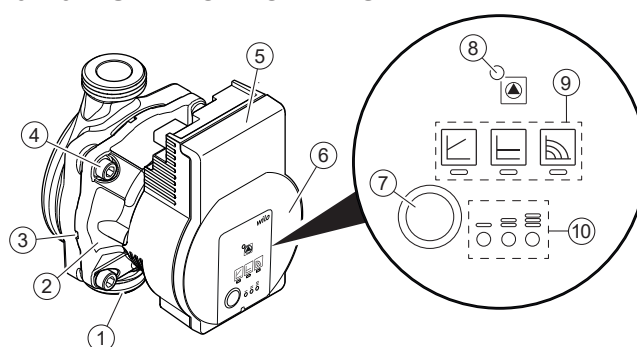

Figure A3-1: Pump components and control panel

1. Pump housing	6. Rating plate
2. Glandless motor	7. Operating button for pump adjustment
3. Condensate drain openings (4 around motor)	8. Run/Fault signal LED
4. Housing screws	9. Display of selected control mode
5. Control module	10. Display of selected pump curve (I, II, III)

A3.1.4 CONTROL PANEL

Indicator LEDs

- Run/Fault signal LED (item 8, Figure A3-1)
 - LED is GREEN when pump is running in normal pump operation.
 - LED lights up red/flashes when there is a fault (refer to Section A3.2).
- Control mode display LEDs (item 9, Figure A3-1)
- Pump curve display LEDs (item 10, Figure A3-1)
- LED combinations are used to indicate when the following functions are in operation:
 - Pump venting (refer to Sections A3.1.5 and A3.1.6 for information on how to activate this function).
 - Manual restart (refer to Sections A3.1.5 and A3.2 for information on how to activate this function).
 - Key lock (refer to Sections A3.1.5 and A3.1.6 for information on how to activate this function).

Operating button - Green (item 7, Figure A3-1)

- Press to select:
 - Control mode
 - Pump curve (within the control mode)
- Press and hold to:
 - Activate the pump venting function (press for 3 seconds)
 - Activate manual restart (press for 5 seconds)
 - Lock/unlock control mode and pump curve (press for 8 seconds)

A3.1.5 OPERATING MODES

Wilo-Para 25-130/7-50/SC-6#GRA circulating pumps have three possible operating modes:

- Variable differential pressure ($\Delta p-v$) with three pre-defined pump curves (I, II and III)
- Constant differential pressure ($\Delta p-c$) with three pre-defined pump curves (I, II and III)
- Constant speed with three pump speed settings (I, II and III)

Variable Differential Pressure Mode ($\Delta p-v$)

Recommended for two-pipe heating systems with radiators to reduce the flow noise at thermostatic valves.

In this mode the electronic control reduces the delivery head of the pump to half in the case of decreasing volume flow in the pipework. There are three pre-defined pump curves (I, II and III) to choose from.

Constant Differential Pressure Mode ($\Delta p-c$)

Recommended for underfloor heating systems.

In this mode the electronic control maintains the set delivery head irrespective of the volume flow from the pump. There are three pre-defined pump curves (I, II and III) to choose from.

Constant Speed Mode

Recommended for systems with fixed system resistance requiring a constant volume flow from the pump.

This is the default setting of the pump and as such is recommended by Grant for heating systems.

In this mode the pump speed is not automatically regulated (as with the Variable or Constant differential pressure modes) but operates constantly at one of the three available speeds (I, II or III)

! NOTE !

Factory default setting is Constant speed mode - pump curve III.

Pump Venting Function

Activated by pressing and holding the green operating button for 3 seconds.

Automatically vents the pump. **This function DOES NOT vent air from the heating system.**

Manual Restart (Unblocking) Function

Activated by pressing and holding the green operating button for 5 seconds.

Unblocks the pump when required, e.g. after a long idle period in the summer.

Key Lock Function

Activated by pressing and holding the green operating button for 8 seconds.

Locks/unlocks the current pump settings set by the operating button, preventing unwanted adjustment of the current pump settings.

Factory Setting Function

Activated by pressing and holding the green operating button whilst switching the pump off, and continuing to hold the button down until all lights on the pump control panel are off.

When the pump is switched back on, it will operate at the original factory settings.

Factory default setting is Constant speed mode - pump curve III.

A3.1.6 COMMISSIONING

After installation of the boiler, commission the pump by using the following procedure:

Venting:

- Fill and vent system correctly. (Refer to Section 7)
- If the pump does not vent automatically use the pump vent function.
- Press and hold the green operating button for 3 seconds and release to start.
- The pump venting function will operate for 10 minutes, during which the pump alternated between off and on to vent air from the pump.
- Pump mode and pump curve LED rows flash in turn at 1 second intervals to indicate when this function is operating.
- To cancel, press and hold green operating button for 3 seconds.
- After 10 minutes the pump automatically reverts to the previously set operating mode, e.g. constant speed -curve III.

! NOTE !

After venting the LED display shows the previous pump settings.

Set Control Mode

- Switch on power to the pump.
- The factory setting is Constant speed mode - pump curve III.
- This will be indicated by the control mode LED and pump curve LED.
- Press the green operating button briefly (approx. 1 second) to change the pump setting.
- Continue to repeat pressing the button, using the following sequence, until the required pump mode and pump curve are set:

Table A3-2: Setting pump control mode

	LED display	Control mode	Pump curve
1		Constant speed	II
2		Constant speed	I
3		Variable differential pressure $\Delta p-v$	III
4		Variable differential pressure $\Delta p-v$	II
5		Variable differential pressure $\Delta p-v$	I
6		Constant differential pressure $\Delta p-c$	III
7		Constant differential pressure $\Delta p-c$	II
8		Constant differential pressure $\Delta p-c$	I
9		Constant speed	III

- Pressing the button for the 9th time returns to the basic setting (constant speed / characteristic curve III).

! NOTE !

Both circulating pumps on all Grant Vortex Combi boilers come factory set at Constant Speed Mode - Pump Curve III and should be left set on this setting.

The heating circuit circulating pump should be set by the installer to suit the system.

Lock Operating Button

- To activate the key lock function press and hold the green operating button for 8 seconds until the LEDs for the selected pump settings briefly flash, then release.
- LEDs flash constantly at 1 second intervals to show that key lock is activated.
- The pump settings can no longer be changed unless the key lock function is deactivated.
- To deactivate the key lock function press and hold the green operating button for 8 seconds, as above.

! NOTE !

All settings and displays are retained if the power supply is interrupted.

A3.2 CIRCULATING PUMP FAULT DIAGNOSIS - WILO-PARA 25-130/7-50/SC-6#GRA

The Run/Fault signal LED (item 8, Figure A3-1) will indicate if there is a fault with the pump and can assist in diagnosing and rectifying that fault as detailed in Table A3-3 below:

Table A3-3: Pump fault diagnosis

Run/Fault LED condition	Diagnostic	Cause	Remedy
Green	Normal Operation	Pump runs according to the pump settings	N/A
Red	Pump is stopped	Pump rotor blocked	Activate pump manual restart function
	Winding	Winding defective	
Flashes red	Under/Over voltage	Undervoltage: Voltage < 160V OR Overvoltage: Voltage > 253V	Check mains voltage and operating conditions (water and ambient temperature)
		Excessive motor temperature	
	Short circuit	Motor current too high	
Flashes red/green	Pump stopped (blocked)	Water flowing through pump but no mains voltage to motor	Check mains voltage, water quantity and pressure and ambient conditions.
	Dry running	Air in pump	
	Overload	Sluggish motor with slower speed than normal operation. Pump is operating outside temperature limits.	
LED off	No power to pump control electrics	Pump is not connected to power supply	Check cable connection
		LED is damaged	Check if pump is running
		Electronics are damaged	Replace pump

Manual Restart (Unblocking) Function:

The pump will attempt an automatic restart if a blockage is detected. If this is not successful, the Run/Fault LED will be constant RED.

To activate the manual restart (unblocking) function:

- Press and hold the green operating button for 5 seconds to activate the manual restart function.
- The restart function will run for up to 10 minutes.
- The pump automatically alternates between forward and reverse operation to unblock the pump.
- Pump mode and pump curve LEDs flash in succession in a clockwise direction to indicate when this function is operating.
- To cancel, press and hold the green operating button for 5 seconds.



GRANT ENGINEERING (UK) LIMITED

Hopton House, Hopton Industrial Estate, Devizes, Wiltshire, SN10 2EU
Tel: +44 (0)1380 736920 Fax: +44 (0)1380 736991
Email: info@grantuk.com www.grantuk.com