

Wessex ModuMax mk3 Boilers

Condensing
Fully Modulating, Pre-Mix, Gas Fired,
Modular Boilers for Heating and
Domestic Hot Water Installations

Installation, Commissioning and Servicing Instructions

Models– 97, 116,
147, 196 & 254

NATURAL GAS I_{2H}
LPG Propane I_{3P}

IMPORTANT NOTE

**THESE INSTRUCTIONS MUST BE READ
AND UNDERSTOOD BEFORE INSTALLING,
COMMISSIONING, OPERATING OR
SERVICING EQUIPMENT**

Customer After Sales Services

Telephone: **01202 662555** E-mail: **service@hamworthy-heating.com** Fax: **01202 662522**

Technical Enquiries

To supplement the detailed technical brochures, technical advice on the application and use of products in the Hamworthy Heating range is available from our technical team in Poole and our accredited agents.

Site Assembly

Hamworthy offer a service of site assembly for many of our products where plant room access is restricted. Using our trained staff we offer a higher quality of build and assurance of a boiler built and tested by the manufacturer.

Commissioning

Commissioning of equipment by our own engineers, accredited agents or specialist sub-contractors will ensure the equipment is operating safely and efficiently.

Service Contracts

Regular routine servicing of equipment by Hamworthy service engineers inspects the safety and integrity of the plant, reducing the risk of failure and improving performance and efficiency. Service contracts enable you to plan and budget more efficiently.

Breakdown service, repair, replacement

Hamworthy provide a rapid response breakdown, repair or replacement service through head office at Poole and accredited agents throughout the UK.

Spare Parts

We offer a comprehensive range of spare parts, providing replacement parts for both current and discontinued products. Delivery options are available to suit you. Please refer to our website for more details.

Wessex ModuMax mk3 Boilers

Condensing
Fully Modulating, Pre-Mix, Gas Fired,
Modular Boilers for Heating and
Domestic Hot Water Installations

Installation, Commissioning and Servicing Instructions

Models– 97, 116,
147, 196 & 254

NATURAL GAS I_{2H}
LPG Propane I_{3P}

NOTE: THESE INSTRUCTIONS MUST BE READ AND UNDERSTOOD BEFORE INSTALLING, COMMISSIONING, OPERATING OR SERVICING EQUIPMENT.

THE WESSEX ModuMax BOILER IS INTENDED FOR USE AS A COMMERCIAL APPLIANCE.

THIS BOILER IS FOR USE ON GROUP H NATURAL GAS (2ND FAMILY) I_{2H} and LPG PROPANE (3RD FAMILY) I_{3P}. PLEASE ENSURE THE RELEVANT INFORMATION WITHIN THIS DOCUMENT FOR EACH SPECIFIC GAS REQUIREMENT IS ADHERED TO PRIOR TO FIRING THE BOILER.

COUNTRY OF DESTINATION : UNITED KINGDOM & REPUBLIC OF IRELAND

THIS BOILER COMPLIES WITH ALL RELEVANT EUROPEAN DIRECTIVES.

PRODUCT IDENTIFICATION No. 86CP58

**PUBLICATION NO. 500001308
ISSUE 'C'
May 2017**

CONTENTS

	Page
1.0 INTRODUCTION	1
2.0 SUPPLY AND DELIVERY	3
3.0 SIZE AND SPACE REQUIREMENTS	6
4.0 SITE LOCATION AND PREPARATION	10
4.1 Site Location	
4.2 Gas Supply	
4.3 Flueing	
4.4 Water Supply	
4.5 Condensate Connections	
4.6 Electrical Supply	
5.0 BOILER ASSEMBLY	15
5.1 Site dis-assembly	
5.2 Boiler Assembly	
5.3 Water Connections	
5.4 Electrical Connections	
6.0 PRE-COMMISSIONING	17
6.1 Gas Supply	
6.2 Ventilation	
6.3 Pipework, Valves and Pump	
6.4 Flue	
6.5 Electrical	
7.0 CHECKS PRIOR TO LIGHTING	18
8.0 INITIAL LIGHTING	21
8.1 Pre-Lighting-up Checks	
8.2 Controls Operation	
8.3 Operating Phases	
8.4 Ignition Controller Check	
8.5 Gas Supply Pressure Check	
8.6 Combustion Checks	
8.7 User Instructions	
9.0 FAULT FINDING	27
9.1 Temperature Limit Thermostat	
9.2 Ignition Controller	
9.3 Wiring Diagram	
10.0 SERVICING	29
10.1 Regular Servicing	
10.2 Annual Service	
10.3 Four Year Service	
11.0 REPLACEMENT OF FAILED COMPONENTS	31
11.1 Hot Surface Ignitor and Flame Probe Assembly	
11.2 Flow/Return Sensor	
11.3 Temperature Limiter	
11.4 Gas Valve	
11.5 Combustion Fan	
11.6 Venturi	
11.7 Burner	
11.8 Ignition Transformer	
11.9 Ignition Controller - LMS	
11.10 Clip in Modules	
11.11 Screen Display	
11.12 Low Gas Pressure Switch	
11.13 Air Pressure Switch	
11.14 Ignition Transformer In-line Fuse	

11.15 Air Inlet Filter

12.0 RECOMMENDED SPARES 35

PICTORIAL AND DIAGRAMATICAL DATA

PAGE

Figure 2.1	Reverse Header Kit as Supplied	5
Figure 2.2	Header Kit Packaged Dimensions.....	5
Figure 3.1.1	Dimensions & Clearances ModuMax 97/116	6
Figure 3.1.2	Dimensions & Clearances ModuMax 147/196/254	7
Figure 3.2.1.1	Manifold Dimensions ModuMax 97/194, 116/232	8
Figure 3.2.1.2	Manifold Dimensions ModuMax 97/291, 116/348	8
Figure 3.2.2.1	Manifold Dimensions ModuMax 147/294, 196/392, 254/508	9
Figure 3.2.2.2	Manifold Dimensions ModuMax 147/441, 196/588, 254/762	9
Figure 4.2	Gas Connection Point	10
Figure 4.4.	Water & Flue Connection Points	12
Figure 4.5.1	Condensate Piping Installation.....	13
Figure 4.5.2	Condensate Connections	13
Figure 4.6	Electrical Connections.....	14
Figure 5.1	Module Fixings	14
Figure 5.2	Flue Collector Box Pre-Assembly.....	15
Figure 5.2.2	Flue Header Connection	16
Figure 5.3.1	Rear Water Connections	16
Figure 7.1	Boiler Gas System Leak Check Diagram	18
Figure 7.2.1	Gas Valve Position	19
Figure 7.2.2	Venturi & Gas Valve -196/254 Boiler.....	20
Figure 7.2.3	Hot Surface Igniter Resistance Check	20
Figure 8.1.1	Gas Valve	21
Figure 8.1.2	General Overview of Low Gas Inlet Pressure Switch	21
Figure 8.2.1	General Overview of Panel Fascia.....	23
Figure 8.2.2	General Overview of Controls	23
Figure 8.3.1	Operating Phases.....	24
Figure 8.6.1	Removal of Sample Point Plug.....	25
Figure 8.6.2	Combustion Analyser Probe Setting	25
Figure 8.6.3	Insertion of Analyser Probe	25
Figure 8.6.4	High Fire Setting.....	26
Figure 8.6.5	Low Fire Setting.....	26
Figure 9.3.2	Wiring Diagram	28
Figure 10.2	Hot Surface Ignitor and Flame Probe Positions	30
Figure 11.4	Ignition Transformer In-line Fuse	34
Figure 11.4	Air Inlet Filter	34

APPENDICES

	PAGE
APPENDIX A	GAS DATA 36
Figure A	General Gas Data 36
APPENDIX B	ELECTRICAL CONNECTIONS AND CONTROLS 38
Figure B	General Electrical Data 38
Figure B1.2	External Control Wiring for Multiple Module Installations..... 39
APPENDIX C	FLUE DATA 40
Figure C	Flue Data Table 40
Figure C1.1.1	Equivalent Flue Resistance Data 42
Figure C1.1.2	Open Natural Draught (B23/B23p) Flue System..... 43
APPENDIX D	VENTILATION 44
Figure D1	Mechanical Ventilation Flow Rates Chart 45
APPENDIX E	WATER DATA 46
Figure E1.1	General Water Data 46
Figure E1.1.1	Typical Piping Layout 47
Figure E1.3	Cold Feed and Vent Pipe Sizes Table 48
Figure E1.3.1	Hydraulic Schematic 1..... 50
Figure E1.3.2	Hydraulic Schematic 2..... 51
Figure E1.3.3	Hydraulic Schematic 3..... 52
Figure E1.3.4	Hydraulic Schematic 4..... 53
Figure E1.3.5	Hydraulic Schematic 5..... 54

1.0 INTRODUCTION

1.1 This boiler must be installed by a competent person.

1.1.2 All installations **MUST** conform to the relevant Gas Safety and Building Regulations.

1.1.3 Health & Safety requirements must also be taken into account when installing any equipment.

1.1.4 Failure to comply with the above may lead to prosecution.

1.2 This boiler is intended for use on Group H Natural Gas (2nd Family) I_{2H} or LPG Propane (3rd Family) I_{3P}

1.2.1 The information relating to Natural Gas & Propane firing is to be found in Appendix 'A'.

1.2.2 Boilers **MUST NOT** use gas other than that for which they are designed and adjusted.

1.2.3 Regulatory disposal and proper recycling of this product can prevent damage to the environment and health risks.

a) For the disposal of the product and the component parts, the services of an accredited waste disposal company should be used.

b) For more information on waste disposal/management, contact the local authority responsible for waste management or the point of sale where the product was purchased.

1.3 The Wessex ModuMax is a gas fired, fully modulating, condensing, fan assisted, open flued central heating / hot water boiler. Using the latest gas / air ratio control technology it is able to provide clean efficient operation across a large output range.

1.3.1 The boiler can be supplied in a modular format, a maximum of three vertically stacked modules being arranged into a single unit sharing a common flue.

1.3.2 Each boiler module utilises a metal fibre, fan assisted, pre-mix burner.

1.3.3 Operation is initiated and controlled by a Navistem boiler management system with a user interface LCD display for accessing and changing boiler parameters.

1.3.4 Each of the boiler models is designed for direct connection to a flue system. The Technical Data for the various arrangements is given in Appendix 'C'. The flue outlets from more than one unit may be connected to a single chimney.

No draught diverter is fitted to the boiler nor is a fixed diverter required in the flue system. However a draught stabiliser may be required for some installations.

1.3.5 The Wessex ModuMax is floor mounted and is intended for the heating of Commercial and Industrial premises.

It may also be used to supply hot water for these premises via an indirect cylinder.

1.3.6 The Wessex ModuMax has a low water content and water flow rates **MUST** be maintained at or above the recommended levels shown in Appendix 'E'.

1.4 If the boiler is to be connected to an un-vented (pressurised) heating system, care must be taken to ensure all extra safety requirements are satisfied and that the relevant interlocks will shut the boiler(s) off should a high or low pressure fault occur.

1.4.1 The pressurisation unit must also incorporate a low level water switch which protects the water pumps and will directly or indirectly shut down the boiler plant should a low water condition occur.

1.4.2 Consideration should also be given to the maximum working pressure of the boiler as given in Appendix 'E'.

Consult Hamworthy Heating Technical Department for help or assistance if in doubt.

1.5 The Wessex ModuMax boiler is not suitable for direct connection to domestic hot water supplies.

1.6 The Wessex ModuMax boiler can be installed with reverse return water flow, (optional HHL pipe kits available) requiring a primary circuit pump and low loss header, or with individual module shunt pumps or electrical isolating valves (not HHL supply)

See Appendix 'E', figure E1.1 for typical schematic layouts

BOILER VARIATIONS

Wessex ModuMax mk3 WM97/97H - Single 97 kW unit
Wessex ModuMax mk3 WM97/194V - Single 194 kW unit. (created by stacking 2 – 97 kW modules vertically).
Wessex ModuMax mk3 WM97/291V - Single 291 kW unit. (created by stacking 3 – 97 kW modules vertically).
Wessex ModuMax mk3 WM116/116H - Single 116 kW unit.
Wessex ModuMax mk3 WM116/232V - Single 232 kW unit
Wessex ModuMax mk3 WM116/348V - Single 348 kW unit
Wessex ModuMax mk3 WM147/147H - Single 147 kW unit.
Wessex ModuMax mk3 WM147/294V - Single 294 kW unit.
Wessex ModuMax mk3 WM147/441V - Single 441 kW unit.
Wessex ModuMax mk3 WM196/196H - Single 196 kW unit.
Wessex ModuMax mk3 WM196/392V - Single 392 kW unit
Wessex ModuMax mk3 WM196/588V - Single 588 kW unit.
Wessex ModuMax mk3 WM254/254H - Single 254 kW unit.
Wessex ModuMax mk3 WM254/508V - Single 508 kW unit.
Wessex ModuMax mk3 WM254/762V - Single 762 kW unit .

1.7 The fully assembled unit is supplied covered with a protective sleeve. The flue assemblies for the stacked models are supplied in a separate pack.

1.8 Each Wessex ModuMax module can be controlled by a 0-10V analogue control input capability which is available via the Navistem boiler control.

1.9 Options

1.9.1 Optional reverse return header kits are available for models:

97/194, 97/291, 116/232, 116/348, 147/294, 147/441, 196/392, 196/588, 254/508 & 254/762

These kits are free-standing allowing installation to the system prior to installing the boiler and can incorporate all necessary valves, inter connecting pipework, and flexible flow and return connections. Refer to individual kit instructions for details.

1.9.2 Controls peripherals

The Navistem boiler management system has the potential to accept the following control options:

1.9.2.1 Clip in Fault Alarm & Run Signal AGU2.550A109

Optional kit for a Run/Fault signal.

(available as a kit from Hamworthy Heating Ltd)

Kit Part No. 563605666

1.9.2.2 Clip in LPB Bus comms OCI345

LPB sequencing of the cascade controlled by Merley / RVS

(available as a kit from Hamworthy Heating Ltd)

Kit Part No. 563605667

1.9.2.3 Additional kits available from Hamworthy Heating :

Merley Sequence Controller - Loose Kit 563605671 or Fully Assembled 563605672

Additional Heating Circuit Kit - 563605673

Domestic Hot Water (DHW) Kit - 563605674

Outside Air Temperature Sensor - 533901457

Room Sensor QAA55 - 533901589

Room Sensor QAA75 - 533901587

1 Zone Heating Circuit Kit - 563605668

2 Zone Heating Circuit Kit - 563605669

3 Zone Heating Circuit Kit - 563605670

1.9.2.4 Regulatory disposal and managed recycling of this product can prevent damage to the environment and health risks.

a) For the disposal of the product and the component parts, the services of an accredited waste disposal company should be used.

b) For more information on waste disposal/management, contact the Local Authority responsible for waste management or the point of sales where the product was purchased.

2.0 SUPPLY AND DELIVERY

Your boiler is despatched to site as a pre-assembled and tested unit. It is the installers responsibility to convey the boiler to the plantroom.

Ensure the boiler is kept secure when handling to avoid it toppling, as this will result in damage.

Each 2 and 3 high stacked Wessex ModuMax model is supplied with a flue collector manifold. This is separately packaged in a dedicated cardboard box. Single Wessex ModuMax boilers do not have an additional flue collector manifold.

NOTE: Care must be taken as impacts will cause damage to the flue collector manifold.

Delivery Verification

When taking delivery please ensure that you have received the correct number of boilers and flue collector manifold to fulfil your order. If any item is missing please contact our after sales service team. Please provide details of your order number and contract number as well as a detailed description of the missing item.

Reverse Return Header Sets

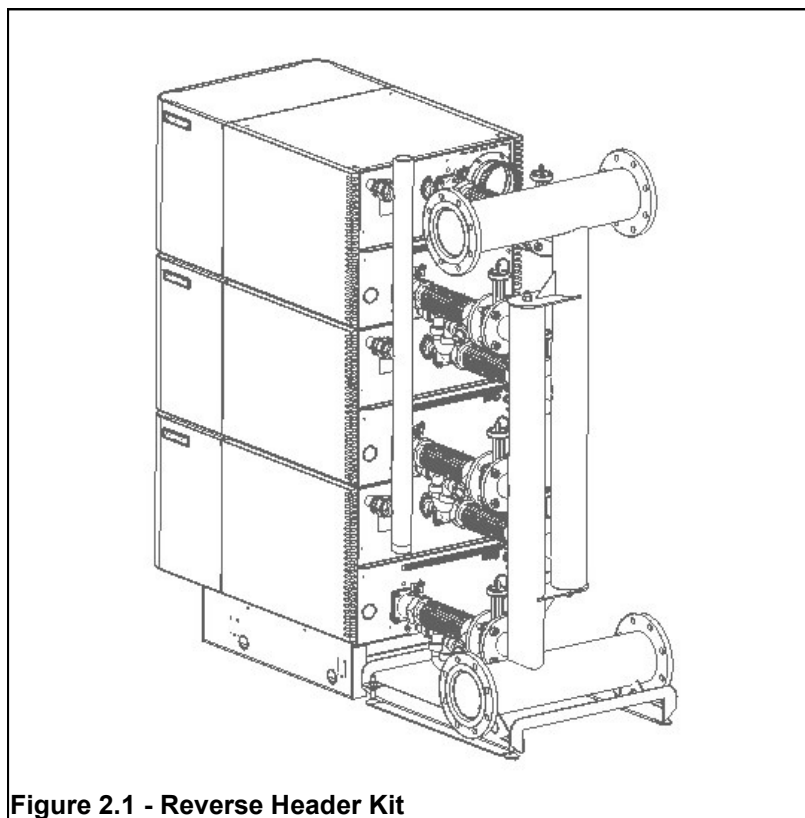

Figure 2.1 - Reverse Header Kit

Where reverse return header sets are used these are packaged separately from the boilers. The packaging for each header set is defined in the table below. Ancillary items such as isolation valves and flexible boiler connectors are packaged in a cardboard box on the same pallet. The whole package is shrink wrapped for security and basic protection.

Model	Depth	Width	Height	Weight
Wessex ModuMax 97/196, 116/232.	1200mm	800mm	1490mm	116Kg
Wessex ModuMax 97/291, 116/348.	1200mm	800mm	2040mm	160kg
Wessex ModuMax 147/294, 196/392, 254/508	1200mm	800mm	1520mm	192kg
Wessex ModuMax 147/441 196/588, 254/762.	1200mm	800mm	2060mm	233kg

Figure 2.2 - Header Kit Packaged Dimensions

3.0 SIZE AND SPACE REQUIREMENTS

3.1 The Wessex ModuMax Series boiler range has been designed to utilise minimum floor space by stacking boiler modules, therefore it is important the plantroom has sufficient ceiling height to allow for installation and connection to the flue system.

Also important is allowance for sufficient access at sides and rear of boiler for flue and pipework connections. See Figure 3.1.1 below.

Figure 3.1.1 - Dimensions and Clearances 97 & 116

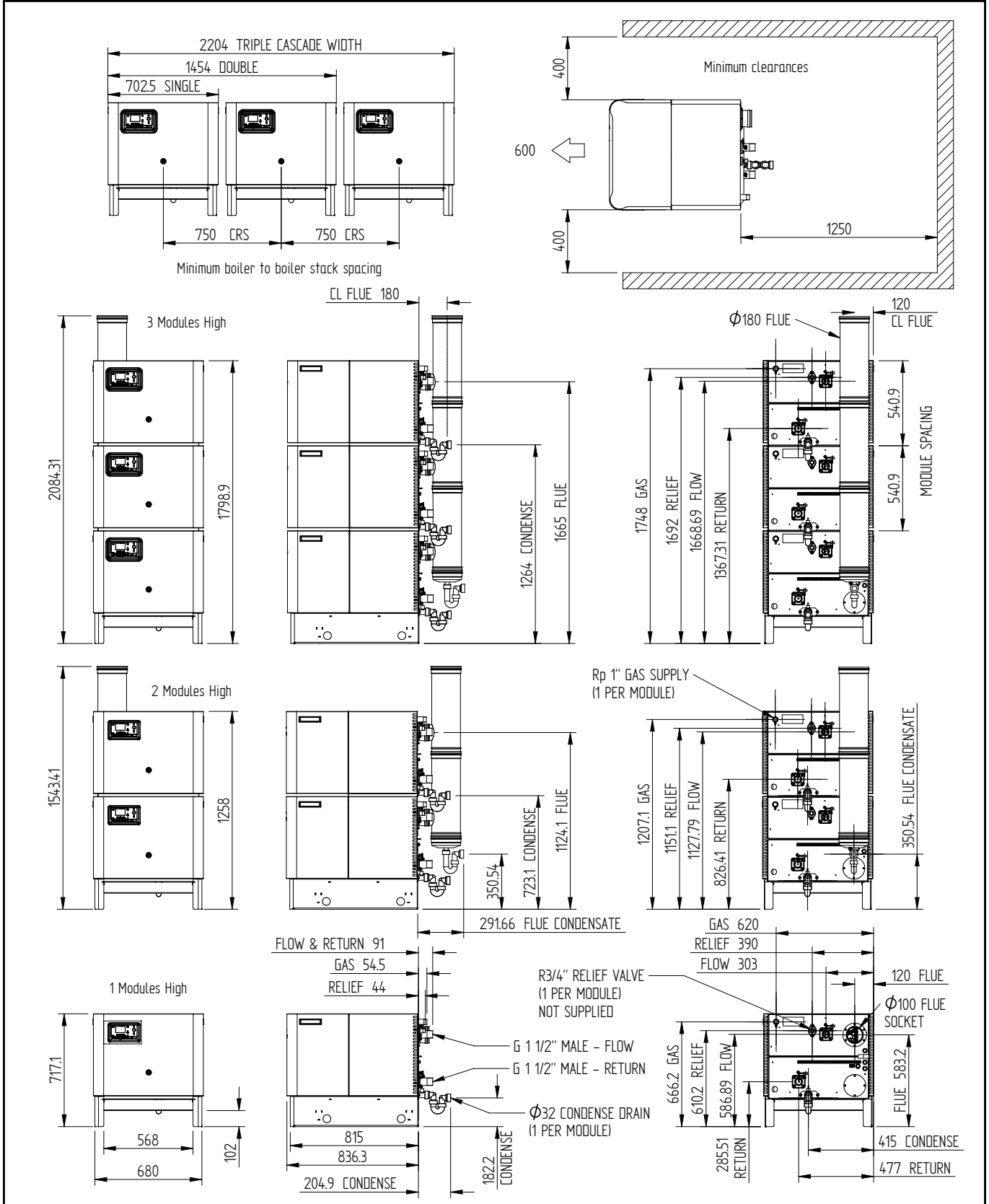
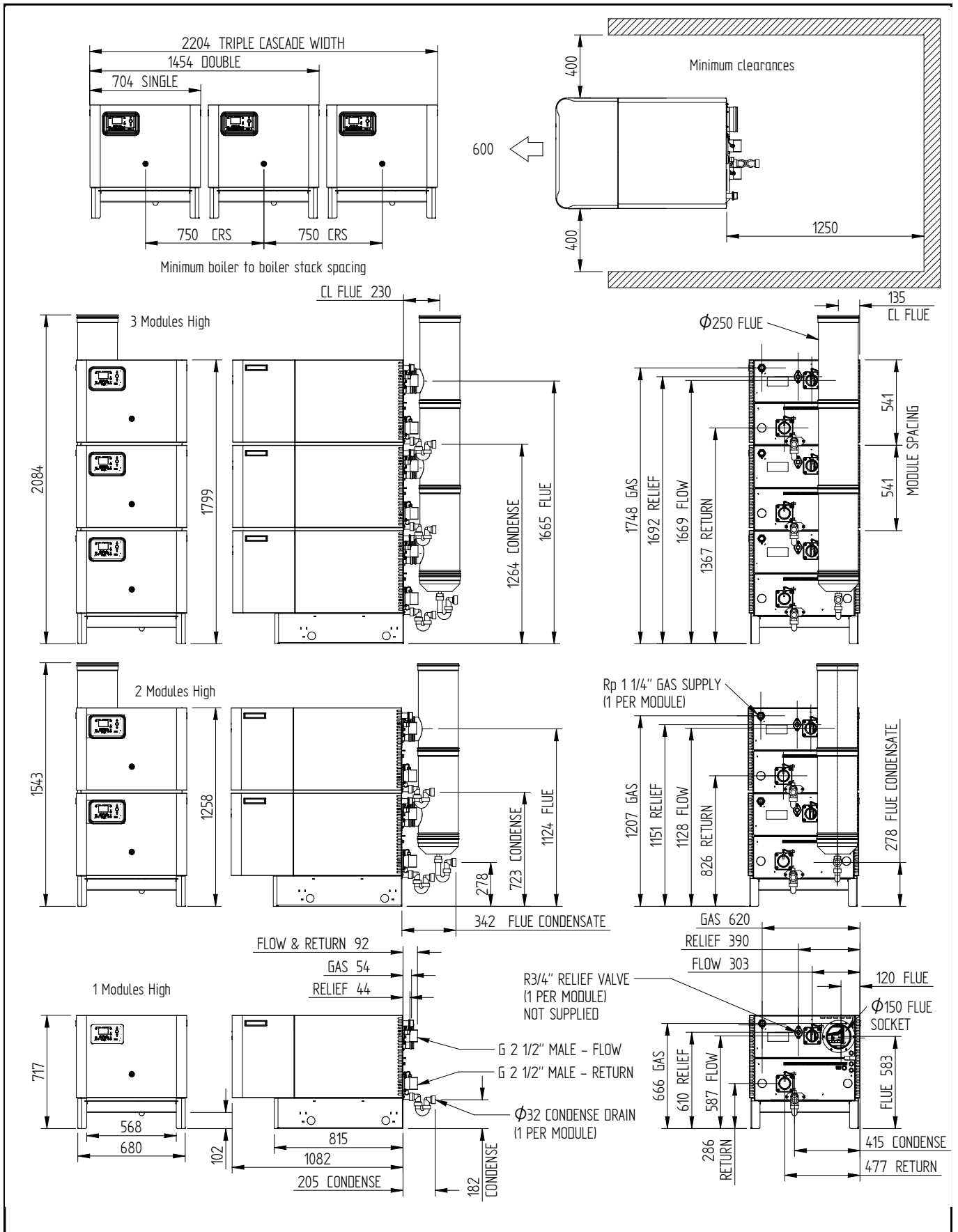

Figure 3.1.2 - Dimensions and Clearances 147/196/254



3.2.1 The Hamworthy Heating Ltd water manifold kit is designed to provide a compact solution for connecting the boilers to the gas supply and flow and return water connections. There are two kits specific to individual models. (Refer to the Installer's Guide 500005117 for specific details on the manifold kit, suitable for 97/116 models)

Optional accessory kits to control shunt pumps and valves can be found on page 2 of this manual

Safety Valve: When using this kit it is important that **each boiler module is fitted with an individual safety valve** using the connection provided on the back of each boiler. This item is not supplied with the boiler.

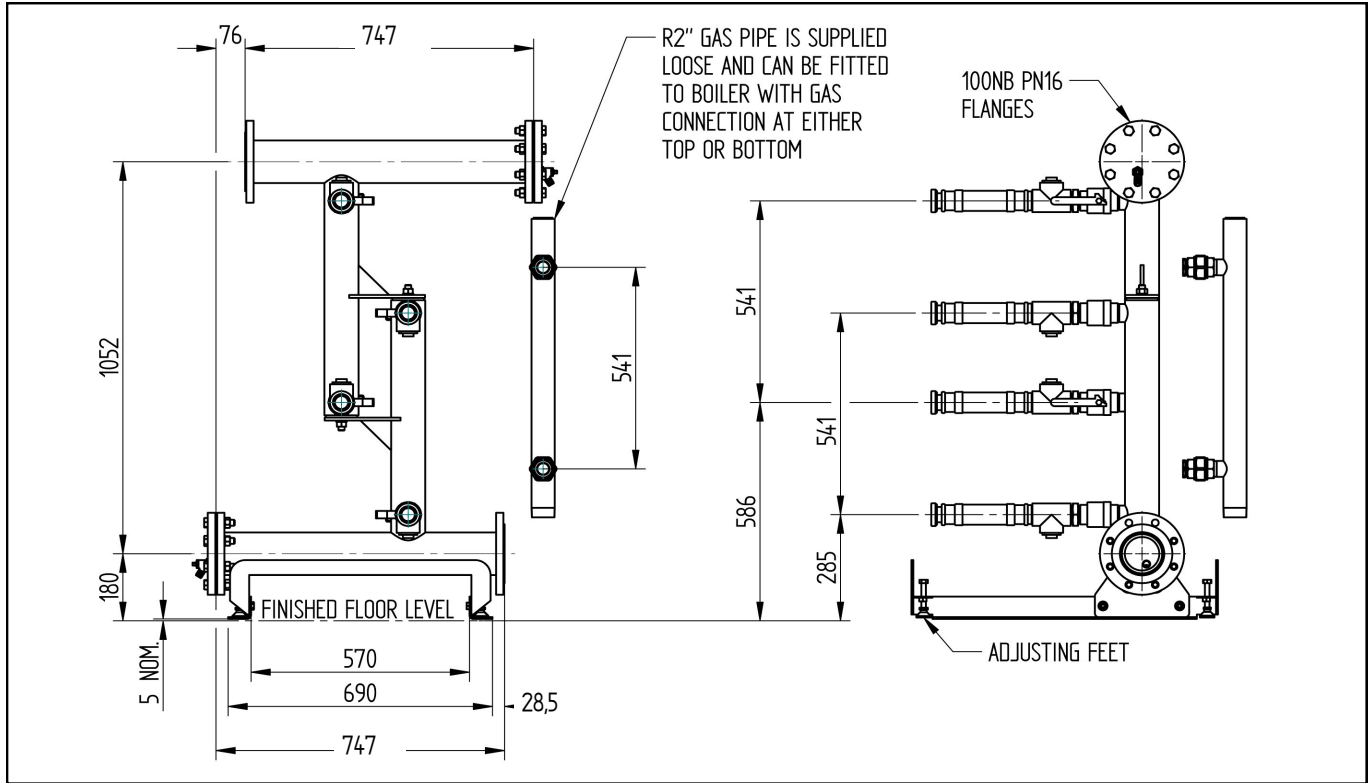

Figure 3.2.1.1 – Manifold Dimensions for ModuMax 97/194 & 116/232

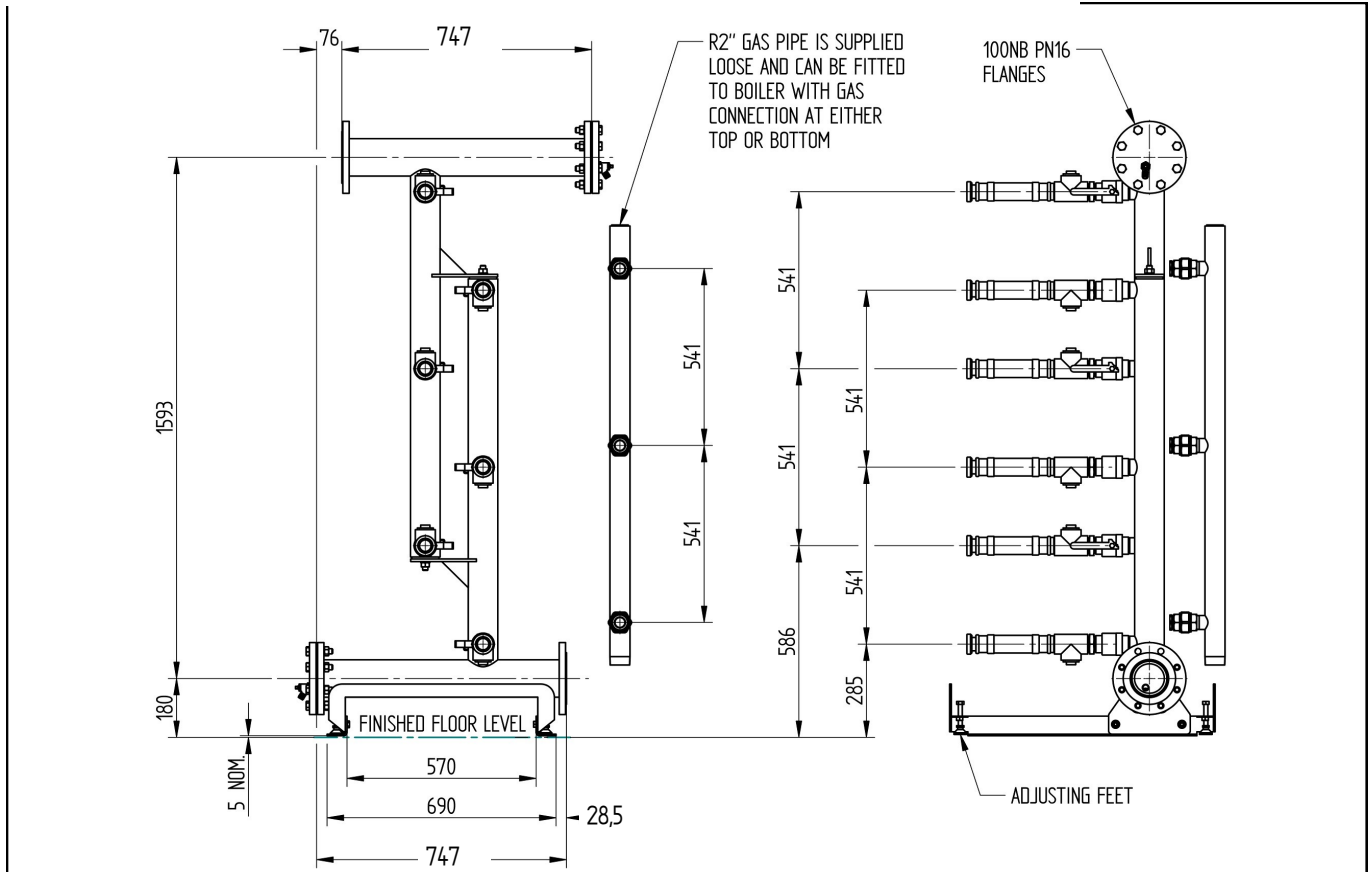

Figure 3.2.1.2 – Manifold Dimensions for ModuMax 97/291 & 116/348

3.2.2 The Hamworthy Heating Ltd water manifold kit is designed to provide a compact solution for connecting the boilers to the gas supply and flow and return water connections. There are two kits specific to individual models. (Refer to the Installer's Guide 500005119 for specific details on the manifold kit, suitable for 147/196/254 models)

Optional accessory kits to control shunt pumps and valves can be found on page 2 of this manual

Safety Valve: When using this kit it is important that **each boiler module is fitted with an individual safety valve** using the connection provided on the back of each boiler. This item is not supplied with the boiler.

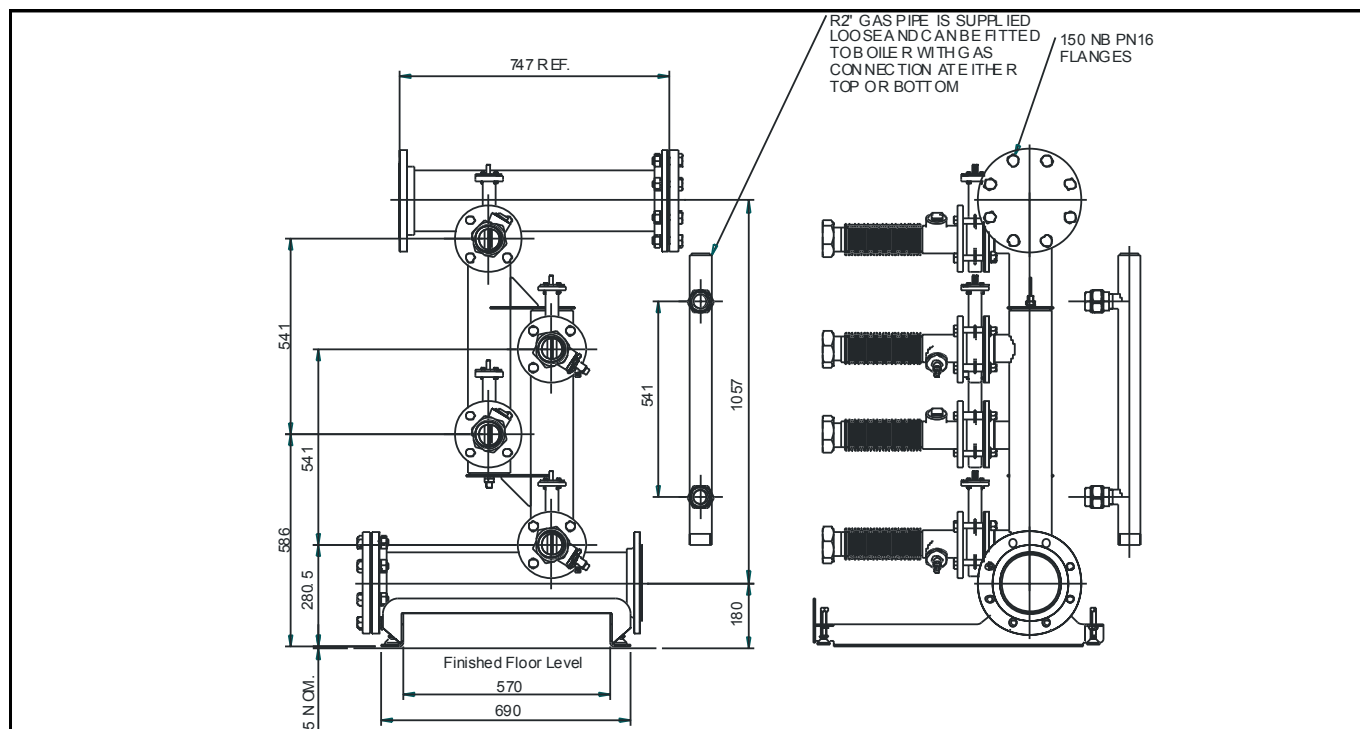

Figure 3.2.2.1 – Manifold Dimensions for ModuMax 147/294, 196/392, 254/508

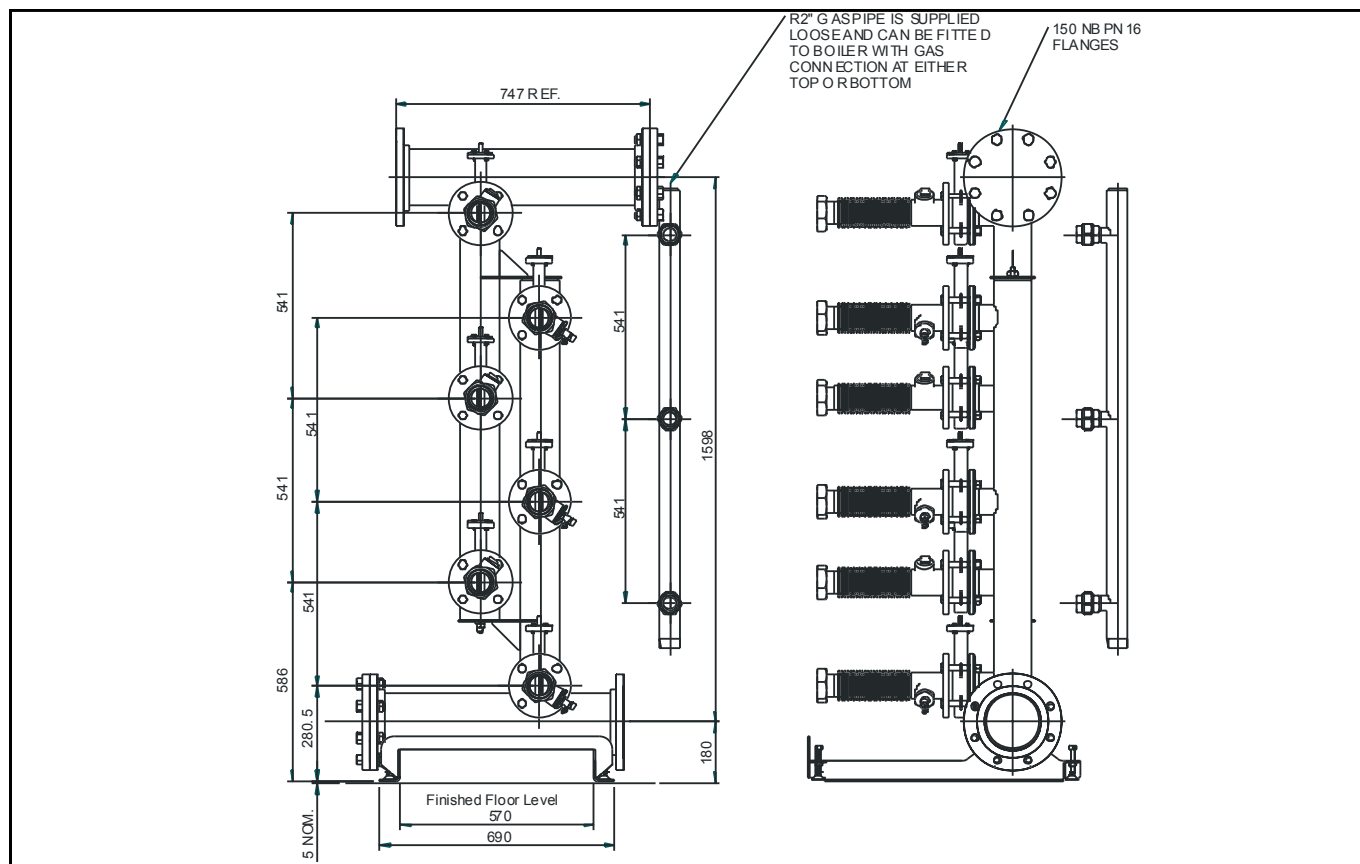

Figure 3.2.2.2 – Manifold Dimensions for ModuMax 147/441, 196/588, 254/762

4.0 SITE LOCATION AND PREPARATION

4.1 Site Location.

DO NOT LIFT THE BOILER BY THE CASING PANELS!

- The floor or plinth for the boilers and water manifold kit must be both flat and level to ensure correct alignment of fittings and connections.
- The floor or plinth must be sufficiently strong to support the weight of both the boilers and manifold kit where used.
- The floor or plinth must be fireproof in accordance with BS 6644.
- The plantroom must have sufficient space for installation of boilers, manifold kits, pipework, pumps controls, flues ventilation, access and servicing and other items of plant.

4.2 Gas Supply.

- Gas supply pipes must be in accordance with BS 6891 or IGE/UP/2
- Gas supply connections to the boiler must not be smaller than the connection on the boiler - Rp1" (97 & 116) & Rp1 1/4" (147/196/254)
- Gas installation must be soundness tested to BS 6891 or IGE/UP/1 & IGE/UP/1A.
- Gas installation must be purged to BS 6891 or IGE/UP/1 & IGE/UP/1A.
- Boiler inlet gas pressure; nominal 20mbar (minimum 17.5mbar) for Natural Gas or nominal 37 - 50mbar (minimum 30mbar) for LPG dynamic at the connection to the boiler.
- Boiler house gas isolation valve must be clearly identified and installed close to the entrance / exit.

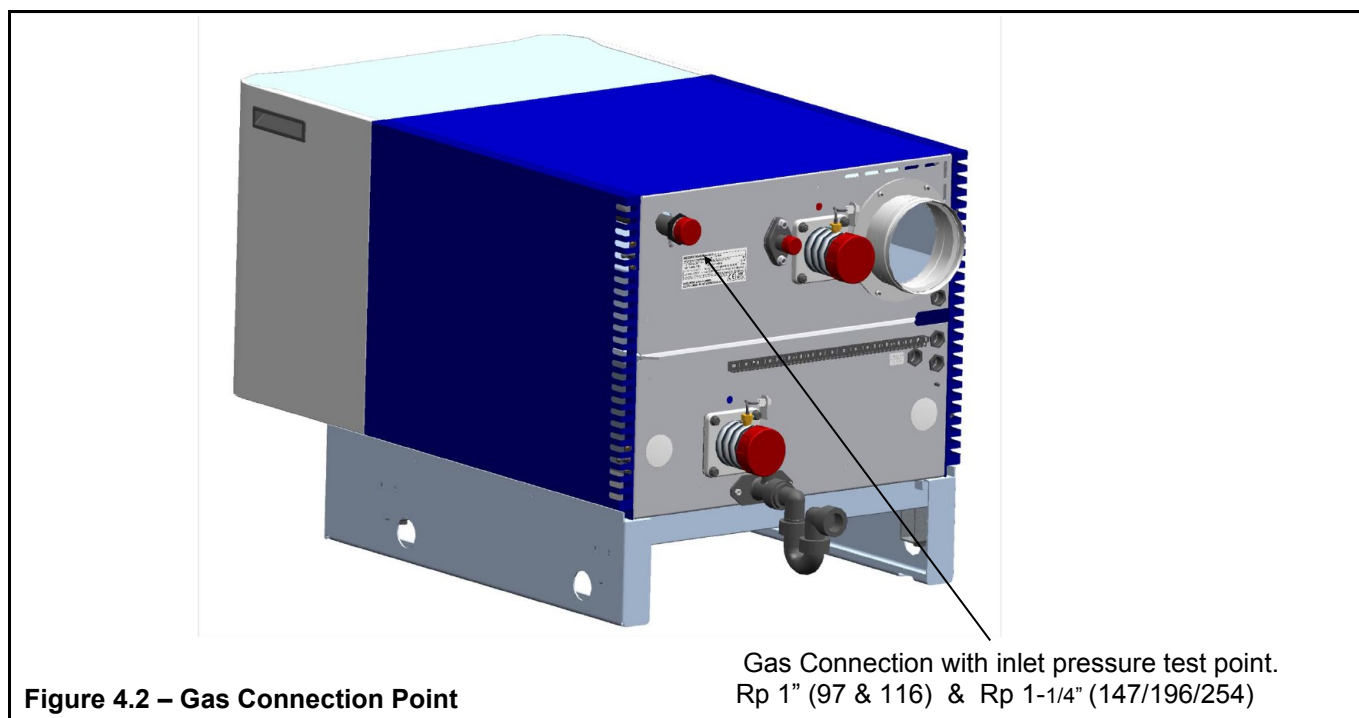

4.3 Flueing

- Flue termination, routing and construction must comply with the requirements of the Clean Air Act 1956, BS 6644 and IGE/UP/10.
- The Wessex ModuMax 97 , 116 ,147, 196 & 254 boilers are intended for connection to a traditional chimney system- refer to Appendix C for installation details.
- Wessex ModuMax 2 and 3 high stacked models must use the headers provided with the boiler prior to any connection to the flue system. A condense trap (32mm dia.) is supplied with the flue header.
- Any flue must be self supporting and separable from the boiler for servicing requirements.
- The maximum number of modules firing into a common chimney is 9. For larger installations refer to HHL Technical
- Due to the low flue gas temperature, 50°C (condensing) - 80 °C (non-condensing), condensation will occur in the flue, flue materials must be non-corrosive and utilise fully sealing joints.
- Flue construction is recommended of a twin wall, insulated type to maintain buoyancy within the flue.
- Adequate facilities must be provided for draining the flue condensation.
- Horizontal flue runs must be kept as short as possible and be inclined at minimum 2° towards the terminal.
- The flue system must be designed acknowledging that there is a positive pressure generated by the boiler combustion fan. Refer to Appendix C.
- The flue system must be designed to limit the max. suction (cold) to 30Pa negative, measured at the connection to the boiler. If the suction is greater than 30Pa, refer to HHL technical.
This condition must then be checked hot and with all boilers firing, the max. pressure at the connection to the boiler should be 150Pa positive.
In the event that the flue system when hot does generate a suction, the max. suction is 100Pa.
- Any stabiliser fitted must be in or close to the vertical chimney.
- Fan dilution - the design must provide for the use of balancing and trim dampers, and their location and operation must be such that the constraints detailed above can be met. Care must be taken to ensure that the fan performance is matched to deliver the appropriate dilution, whilst ensuring that excessive suction is not applied to the boilers. If in doubt, refer to HHL Technical.
- Fan assist - the use of fan assist is not recommended as the boilers have sufficient fan performance to drive the system. If in doubt, refer to HHL Technical.

4.4 Water Supply

- Feed and Expansion tanks to comply with static height requirements of HSE document INDG436.
- Cold feed and open vent pipes to comply with requirements of BS 6644.
- Pressurised system to comply with BS 7074.
- It is recommended that the system pipework is flushed twice before fitting the boiler and using a water treatment.
- It is recommended that the heating system water is treated
- In hard water areas (>180mg CaCO₃/litre) precautions such as water treatment are strongly recommended to prevent the build up of sludge and scale and also to control the system water pH to between 7.0 & 8.0.
- Leaks in the system pipework should be fixed to prevent dilution of water treatment. To monitor the volume of make-up water entering the system, a water meter must be fitted and readings recorded in a log book to be retained on site. Do not top up with more than 5% of the installation's water content in any one year.
- Maximum working water pressure is 10bar (1000 kPa).
- For minimum water pressure see Appendix 'E' - Water Data

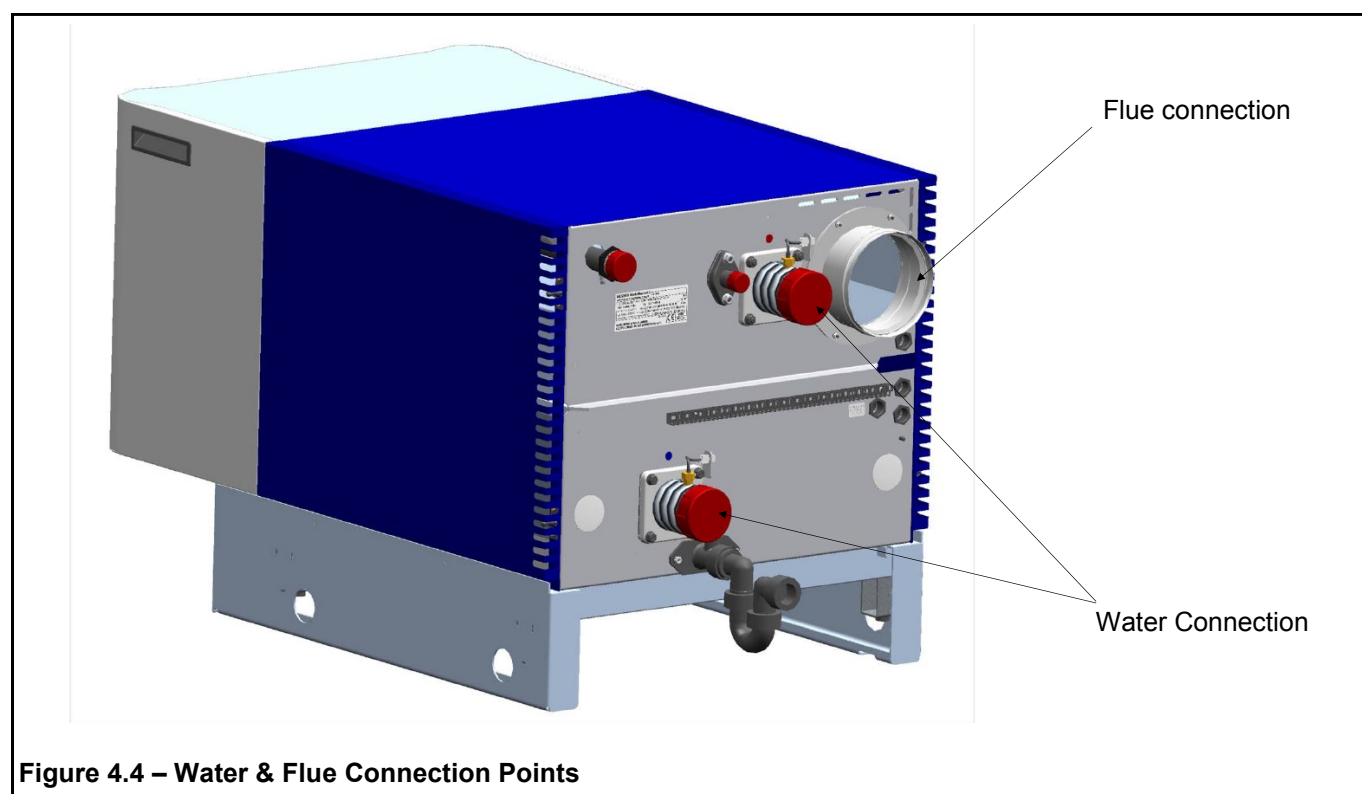

Figure 4.4 – Water & Flue Connection Points

4.5 Condensate Connections

- Provision must be made for removal of condensate from the boiler and flue system.
- Condense is mildly acidic, typically pH3 - pH5.
- Condense pipework must be non-corrosive and not copper. Hamworthy recommend 32mm dia. Plastic waste pipe. Typical volume of condensate produced is 15l/h per 100kW
- Condense may be discharged to a standard drain subject to National or Local regulations.
- Location of condensate pipework should prevent freezing within tundish's, traps and pipework.
- The connection to the boiler condensate drain accepts a straight push-fit coupling for 32mm i.d. plastic waste pipe.

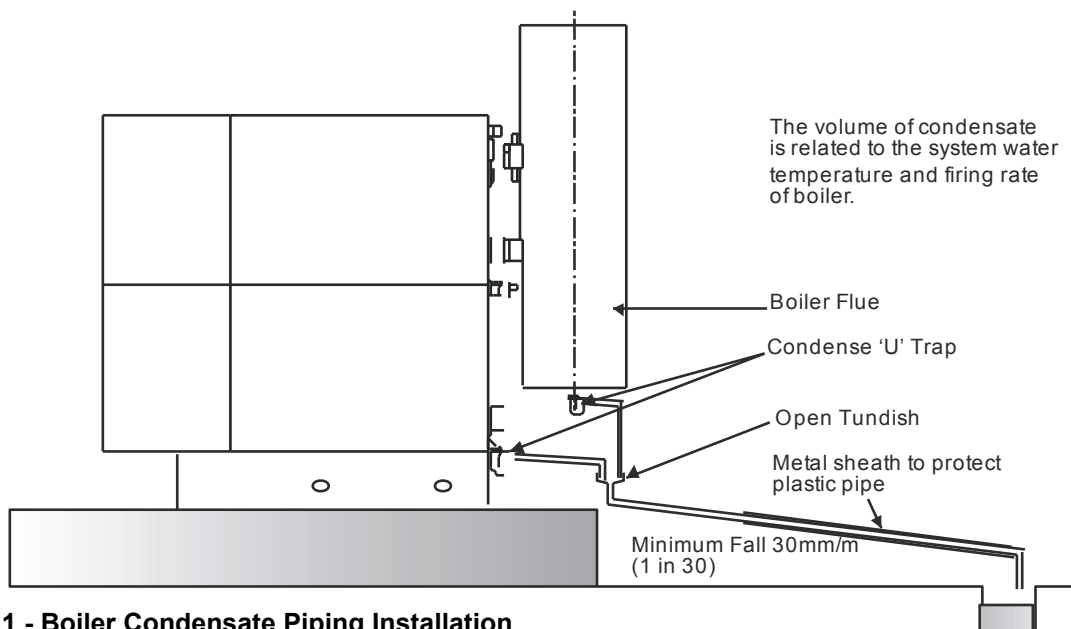

Figure 4.5.1 - Boiler Condensate Piping Installation

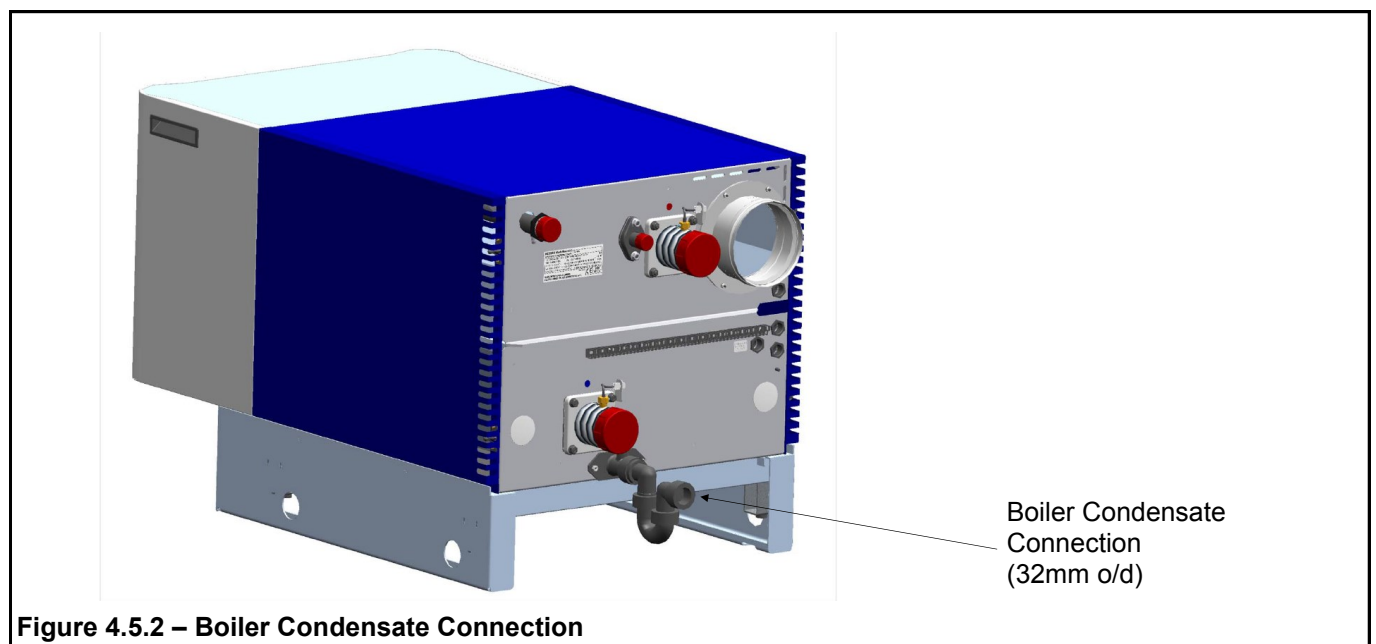

Figure 4.5.2 – Boiler Condensate Connection

4.6 ELECTRICAL SUPPLY

WARNING! THIS APPLIANCE MUST BE EARTHED IN ACCORDANCE WITH IEE REGULATIONS

- Boiler electrical supplies must not be switched by a time clock.
- Boilers are suitable for 230Volt, 50Hz supply.
- External fuses should be rated for 10 amps
- Wiring must be completed in heat resistant cable size 1.0mm² csa.
- Each module should have individual means of isolation.
- Electrical isolators must facilitate complete electrical isolation.
- Electrical isolators must have contact separation of minimum 3mm in all poles.
- Electrical isolators must be installed in readily accessible locations.
- Electrical supplies to boiler modules should only serve the boiler using the conduits supplied. High & low voltage cables should be separated into individual conduits.
- Where volt free contacts are used, these too must be individually isolatable.
- Time clock control should be via the boiler modules stop/start circuit (24V DC).

ADDITIONAL INFORMATION REGARDING ELECTRICAL SUPPLIES IS GIVEN IN BS EN60335, Part 1.

NOTE: The appliance must be isolated from the electrical supply if electric arc welding is carried out on connecting pipework.

FOR DETAILED WIRING INSTRUCTIONS SEE SECTION 5.4 & 9.3

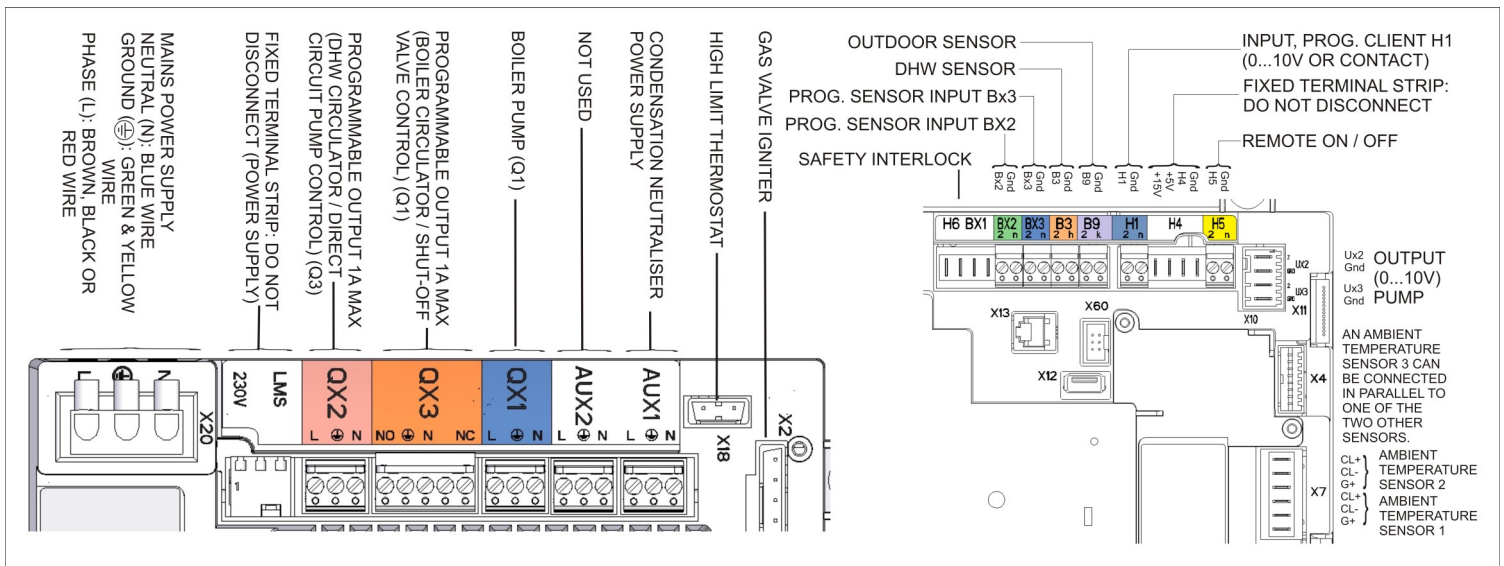

Figure 4.6 - Navistem Electrical Connections

5.0 BOILER ASSEMBLY

General

Boilers are despatched to site as fully assembled units. The flue collector box (stacked models only) and pipework manifold set (where applicable) are the only items that will need assembling on site.

Where access is a problem, stacked models can be broken down into individual modules and then re-assembled in the appropriate location in the plant room - **see section 5.1**

During dismantling and assembly it is important to take care to prevent damage to the boiler casing.

Boiler positioning must allow the minimum clearances detailed in Section 3.0 to facilitate access for flue and pipework connections as well as maintenance.

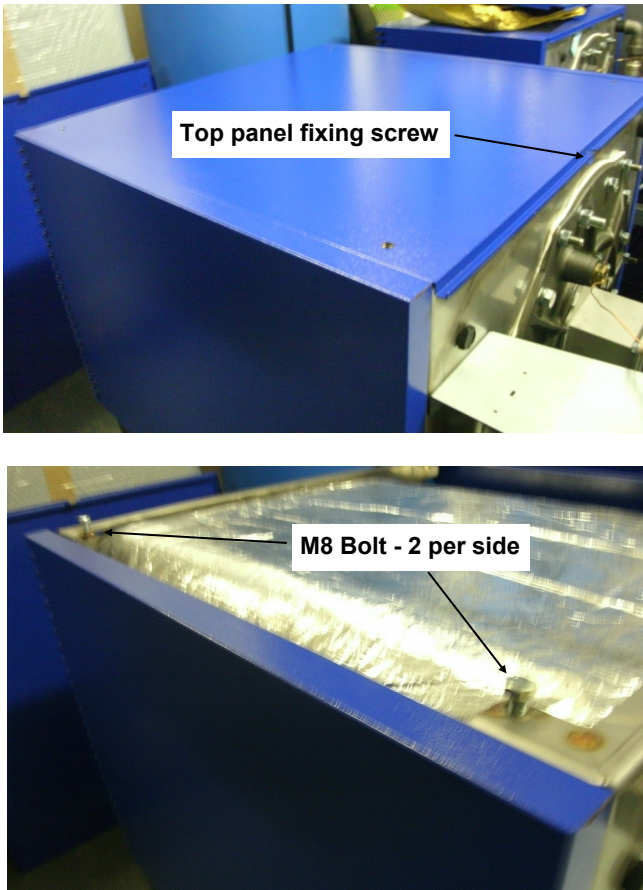

Figure 5.1 Module fixings

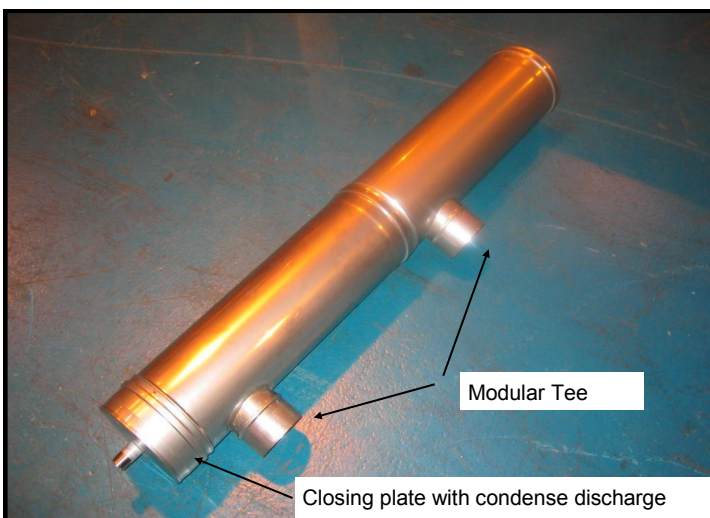

Figure 5.2 - Flue Collector Box Assembly

5.1 - Site dis-assembly

The individual modules are secured by 4 x M8 bolts securing the boiler frames together - see figures 5.1

5.1.1 To access the M8 bolts, remove the M8 socket head screw securing the top module front cover and carefully lift the cover up, disengaging the locating bracket while lifting off the cover. Carefully place the cover aside for re-assembly.

5.1.2 Remove the pozi screw securing the top panel to the boiler frame and remove the top panel, placing aside for re-assembly.

5.1.3 Carefully disengage both casing side panels from the M6 ballstuds.

5.1.4 Access the 4 - M8 bolts (2 per side) and withdraw the bolts from the frame. The top module is now free to carefully lift off the lower module.

Warning - the top module is heavy and will require the appropriate use of lifting methods & equipment (155kg 97-116 models & 200kg 147-254 models).

5.1.5 4 x M8 lifting eyes must be placed in the M8 holes in the top of the boiler frame to provide lifting points.

5.1.6 With the base module in the appropriate position, carefully rebuild the stacked modules, securing with the M8 bolts and refit the side panels, top cover and front cover.

5.2 Boiler Assembly

5.2.1 With the boiler in its desired location, loosely engage the flue collector ducts into each other and position such that the spigots will fit into the respective flue sockets at the rear of the boiler.

In assembling the flue ducts, it is advisable to lubricate the seal located in the socket fittings to enable easy movement and adjustment.

5.2.2 Fit and secure the bottom closing plate to the base of the duct assembly.

Do not fit the flue collector at this stage as it may restrict access to the other connections.

Note: Should modules be arranged in banks of 2 or 3 high, adjacent to each other, it is advisable to fit the water and flue connections to each individual bank prior to fitting the connections to the adjacent bank(s).

Figure 5.2.2 - Flue Header Connection

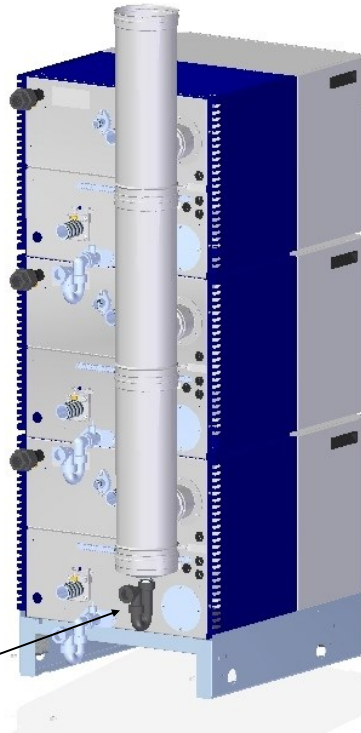

32mm condense trap fitted for connection to drain

Prior to fitting the flue collector assembly, check all water and gas connections for soundness.

Lubricate the seals on the boiler flue spigot to enable easy movement and adjustment.

Adjust and fit the assembled flue collector box to the boiler flue spigots and fit the condense drain discharge pipe to the base of the flue using the fitting supplied.

5.3 Water Connections:

The following connections are provided on each boiler module;

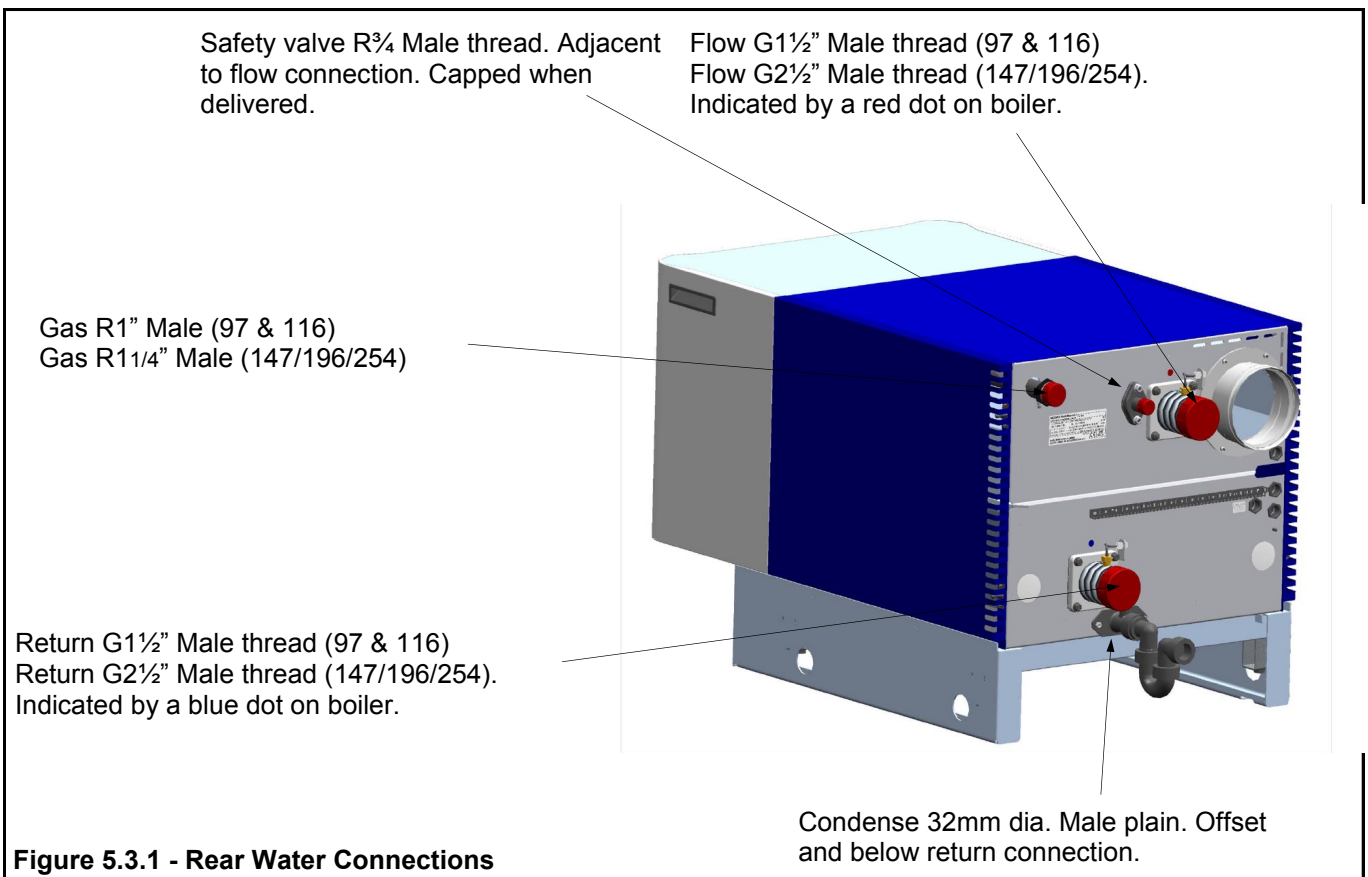

Figure 5.3.1 - Rear Water Connections

Connecting flue pipework must be self-supporting to avoid stress on the boiler connections. Local unions are recommended in the flue pipework to facilitate future servicing requirements.

Open Vented Systems

Boilers must not be capable of isolation from the vent pipe. Valves between boiler and vent pipe to be three way type such that when boiler is isolated from vent pipe it is open to atmosphere. Safety valves should be mounted on the boiler using the connection provided.

Sealed Systems

Boilers must not be capable of isolation from the safety valve. Valves between boiler and safety valve to be three way type such that when boiler is isolated from the safety valve it is open to atmosphere. Hamworthy Heating Ltd recommend using the safety valve connection provided on the boiler.

Where using Hamworthy Heating Ltd pipework kits, assembly of these is detailed in Operation and Maintenance manual 500005117 (97 & 116), 500005119 (147/196/254) supplied with kit.

5.4 Electrical Connections:

The following electrical connections are provided on each module.

- Supply: Live, Neutral and Earth. See Section 4.5 for details.
- Optional Boiler Fault Alarm & Normal Run Signal Output (optional AGU clip-in kit)
- 0-10v Analogue Control Signal Input
- Remote on/off Control Input
- Boiler Pump Output, DHW pump output, motorised valve output
- Safety Interlock Circuit Input
- Optional LPB Bus for use with Merley cascade control (optional OCI clip-in kit) & Master/Slave sequencing

6.0 PRE-COMMISSIONING

The following pre-commissioning check must be carried out before the boiler is commissioned.

6.1 Gas Supply.

Ensure that gas installation pipework and meter has been soundness tested and purged to IGE/UP/1 or IGE/UP/1A as appropriate. Test and purge certificates should be available for viewing.

6.2 Ventilation

Ensure that ventilation and air supply to plant room is correct. Air supply slots in casing panels are clear and open.

6.3 Pipework, Valves and Pump

Ensure that;

- Pipework and valve arrangement is installed to Hamworthy Heating recommendations.
- Circulating system is full of water, vented and pressurised appropriately and the water quality checked.
- Circulation pump is fitted, working and interlocked where required.
- Pipework connections to boiler are fitted correctly.
- All necessary isolation valves are open.
- Safety valve is correctly sized and located.
- Condense connections on boiler and flue are connected and piped to drain.
- Heat load is available.

6.4 Flue

Ensure that;

- Flue system is correctly designed and installed to suit boilers.
- Flue passages to chimney are clear.

6.5 Electrical

Ensure that;

- Electrical connections are correct and isolatable.
- External controls are operational.

WARNING: WHEN THE FRONT COVER IS REMOVED AND THE BOILER IS OPERATIONAL, CARE MUST BE TAKEN WITH ELECTRICAL COMPONENTS AND ACCESS TO PRIMARY INSULATION.

7.0 Checks Prior to Lighting

IMPORTANT: BEFORE PROCEEDING ENSURE THAT THE PRE-COMMISSIONING CHECKS ON PAGE 14 HAVE BEEN CARRIED OUT AND THE RESULTS SATISFACTORY.

7.1 Boiler Gas System Leak Check

Pull off front cover moulding & ensure that the appliance manual gas service valve is in the **OFF** position. Although the boiler receives a gas leak check and gas train component integrity check prior to leaving the factory, transport and installation may have caused disturbance to unions, fittings and gas valve assemblies etc.

A procedure guide is given below. Care must be taken not to allow leak detection fluid (if used) on or near any electrical parts or connections.

NOTE: When testing 2 or 3 high stacked appliances the test detailed below must be carried out on each module.

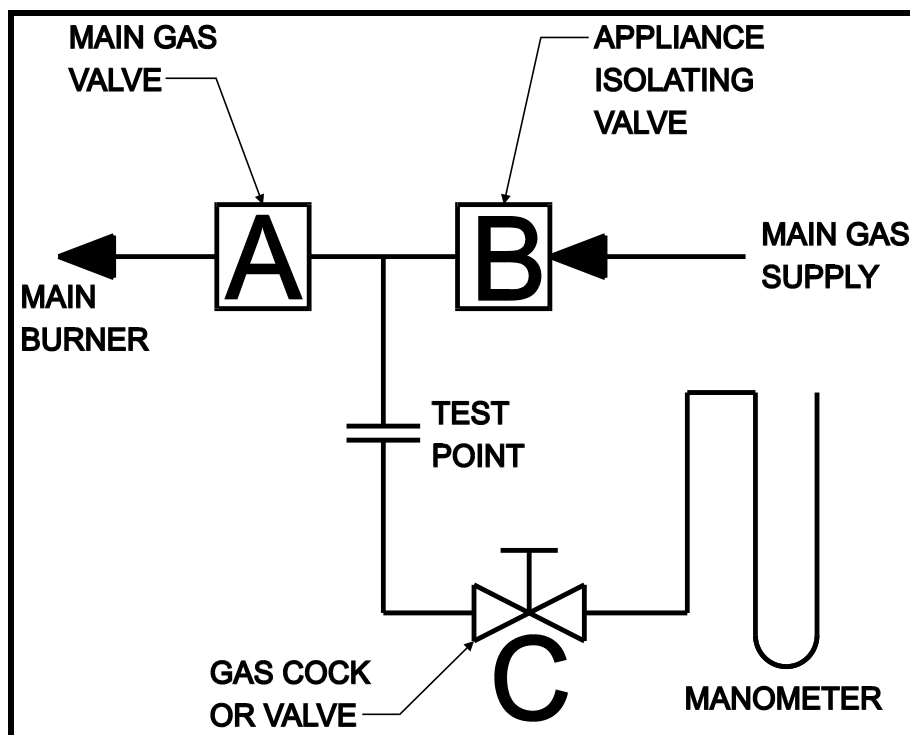

Figure 7.1 - Gas System Leak Check Diagram

Note:-

Main Gas Supply Pressures are as follows;
Natural Gas - 20mbar, LPG - 37mbar.

TO CHECK B

- 1) Turn off the electrical power and gas to the appliance.
- 2) Connect the manometer assembly to test point (Fitted on the inlet to the gas valve).
- 3) With A and B closed open C and monitor manometer over a 2 minute period, a rise indicates a leak on valve B.

TO CHECK A

- 1) Open C.
- 2) Open B to produce the mains gas supply pressure between A and B.
- 3) Close B.
- 4) System may be considered sound if over a period of 2 minutes any drop in pressure is less than 0.5 mbar

Note:- Allow a manometer stabilisation period of approximately 1 minute before each 2 minute check period. Following soundness tests close valve B and remove manometer connections and tighten test points.

7.2 Refer to Appendix A, Gas Data Tables, for maximum inlet pressure for normal operation.

The Following checks must be made prior to lighting the boiler;



Figure 7.2.1 - Gas Isolating Valve (97 & 116 shown)

1. Ensure that the gas supply is connected, but the boiler module gas service (isolating) valve(s) are **closed**, any unions or fittings are correctly tightened and test points are **closed**.

2. Ensure the electrical mains supply is correctly connected but the boiler module isolator(s) are **switched off**. Check all wiring loom connections such as fan or gas valve are correct and secure. Remove the clip, limit stat bulb and tension spring from the pocket in the front of the heat exchanger, and carefully apply a heat source to the bulb.

Note - take care not to damage the tension spring in removal and replacement!

Check the continuity with a meter. If satisfactory, refit the bulb and tension spring in the pocket and secure with the clip. Ensure that all thermostat bulbs are fully inserted into their pockets. The flow and return sensor bulbs are located at the rear of the boiler in the flow and return pipes.

3. Check setting of both temperature limiter and control thermostat. The temperature limiter is factory set at 95°C. The control thermostat is set using the rotary dial on the fascia as detailed in **the separate User Instructions**, HHL part no. 500001309.

4. The flame ionisation signal generated whilst the boiler is firing, can be viewed directly from the display by accessing information level. The value is set to read dc μ A. Refer to **the separate Navistem manual**, HHL part no. 500001310.

5. To ensure correct ignition of the boiler it is recommended to check the resistance of the hot surface igniter. This should be checked cold, using a suitable ohmmeter, by disconnecting the igniter from the control panel cable and measuring the resistance across the pins of the 2 way connector. The reading should be between 70 & 200 ohms **refer to figure 7.2.3**

6. Before ignition of the boiler it must be ensured that all parts of the appliance are clean and free from debris. Special attention should be paid to ensuring that the inlet to the venturi via the air filter is clean and unobstructed.

7. Ensure the heating system circulation / shunt pump is operational and that the pipework is free of air.

8. The flame ionisation signal generated whilst the boiler is firing, can be viewed directly from the display screen. The value is set to read dc μ A.

Figure 7.2.2 - Venturi & Gas Valve (97/116/147 shown)

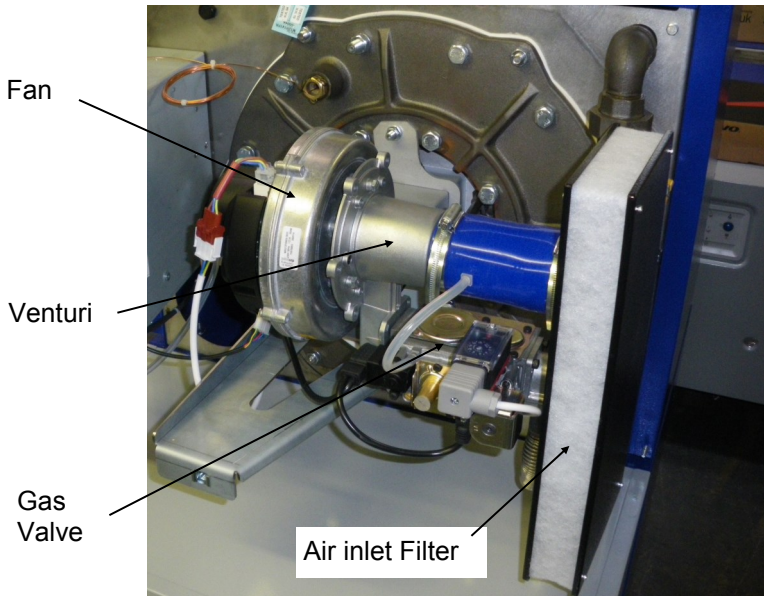

WARNING: WHEN THE FRONT COVER AND AIR FILTER ARE REMOVED AND THE BOILER IS IN OPERATION, IT IS POSSIBLE FOR ARTICLES OF CLOTHING OR LONG HAIR TO BE DRAWN INTO THE VENTURI / FAN.

Figure 7.2.3 - Hot Surface Igniter Check (196/ 254 shown with air filter removed)



Flame Signal Assessment

8.0 INITIAL LIGHTING

Only competent persons registered for working on non-domestic gas appliances should attempt the following operations. Before attempting to commission any boiler, ensure that personnel involved are aware of what action is about to be taken.

8.1 Carry out the following procedure to fire up the boiler:



Figure 8.1.1 - Gas Isolating Valve

1. Ensure the boiler module gas service (isolating) valve is closed (Figure 8.1.1)

2. Check and adjust if necessary the low gas inlet pressure switch located on the side of the boiler gas valve (fig. 8.1.2).

Setting should be

97, 116 & 147 to 7 mbar

196 and 254 to 7.5 mbar

3. Switch on the electrical supply, and initiate the start up sequence. Refer to **separate Navistem manual**, HHL part no. 500001310.

4. As the gas valve is closed, the low gas pressure switch will prevent the boiler from firing and the error code 'E132' will be displayed on the screen. Refer to **separate Navistem manual**, HHL part no. 500001310.

5. If the above procedure occurs correctly, open the gas isolating valve and the fault indication will extinguish.

The boiler will commence its ignition sequence as previously described. This time, when the gas valve is energised the burner will ignite.

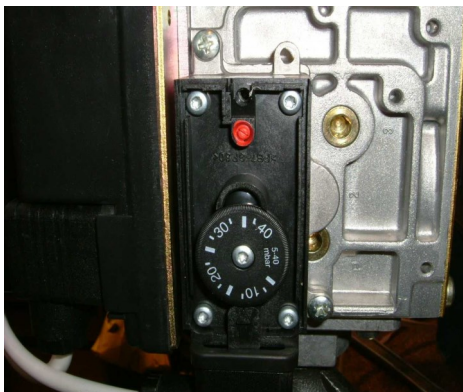

196/254

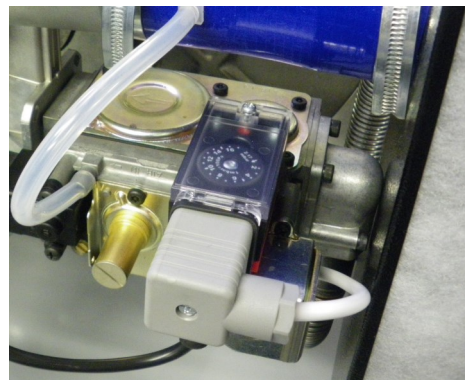

97/116/147

Figure 8.1.2 - Low Gas Inlet Pressure Switches

6. With the burner firing, the flame signal displayed, should be approximately 9-12 μ A, but not less than 3 μ A. Refer to **separate Navistem manual**, HHL part no. 500001310.

- At the end of the ignition proving period, 5 seconds, the hot surface igniter system will be switched off.
- After a period of 15 seconds the fan will alter speed and the burner modulation will be set according to the heat load.
- If after the 5 second flame proving period the flame signal is below 3 μ A the boiler will shut down and attempt one restart.

NOTE: THE BOILER IS EQUIPPED WITH A RESTART FACILITY AND WILL ATTEMPT A SECOND IGNITION, DURING WHICH THE ABOVE PROCEDURES WILL BE REPEATED. AT THE END OF THE RESTART PROCEDURE, IF NO FLAME IS DETECTED AFTER THE FLAME PROVING PERIOD, THE BOILER WILL LOCKOUT. THE BOILER WILL NOT OPERATE UNTIL THE LOCKOUT HAS BEEN MANUALLY RESET.

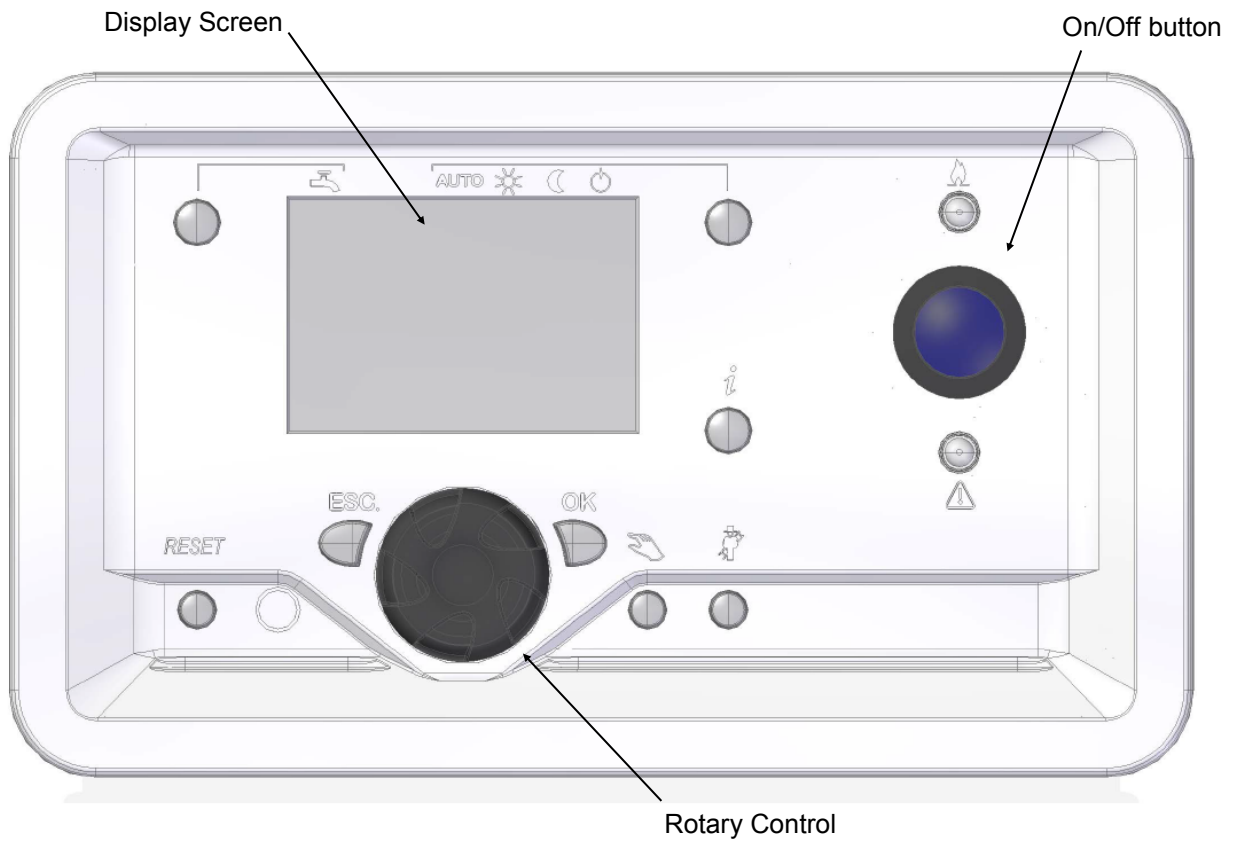

Figure 8.2.1 - General Overview of Panel Fascia

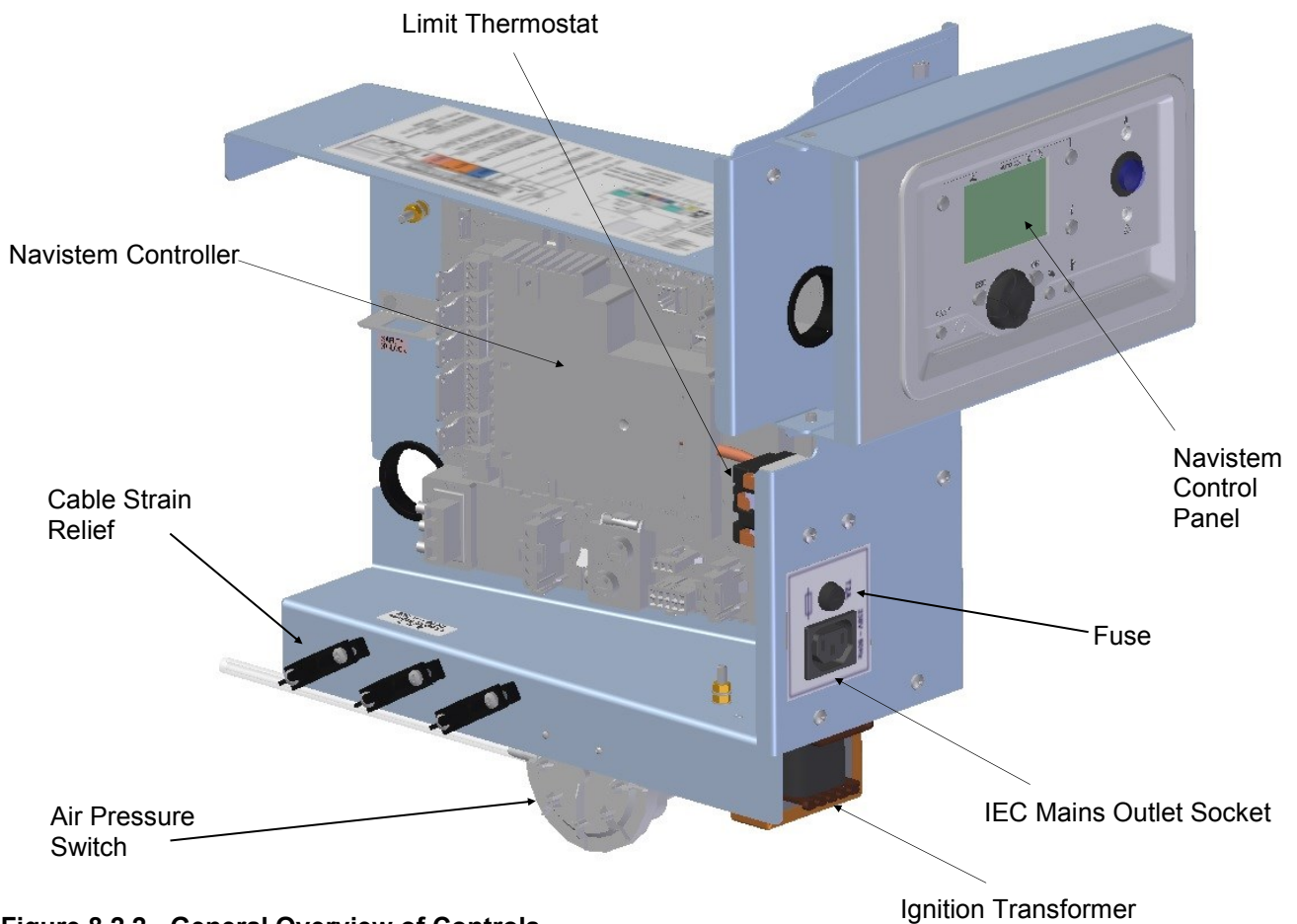

Figure 8.2.2 - General Overview of Controls

8.2 CONTROLS OPERATION

Each ModuMax boiler is controlled by a Navistem boiler controller. The controller functions, settings and configurations are accessed via the rotary dial on the individual fascia panels (fig. 8.2.1)

Comprehensive details and instructions on setting and using the boiler controller can be found in the separate **Navistem** instruction manual, HHL part no. 500001310, which is supplied with each boiler.

A concise user instructions guide (HHL part no. 500001309) is supplied with each boiler. This guide gives instruction on initial set up as well as a list of possible error codes.

The Navistem controller is located on the main control panel assembly which can be accessed after removal of the boiler front cover (fig.8.2.2).

Note: Should remedial work be carried out on a module, then the non-firing module must be electrically isolated so as to prevent accidental operation in the event that the installation is required for ongoing heating requirements.

Figure 8.3.1 - Operating phases

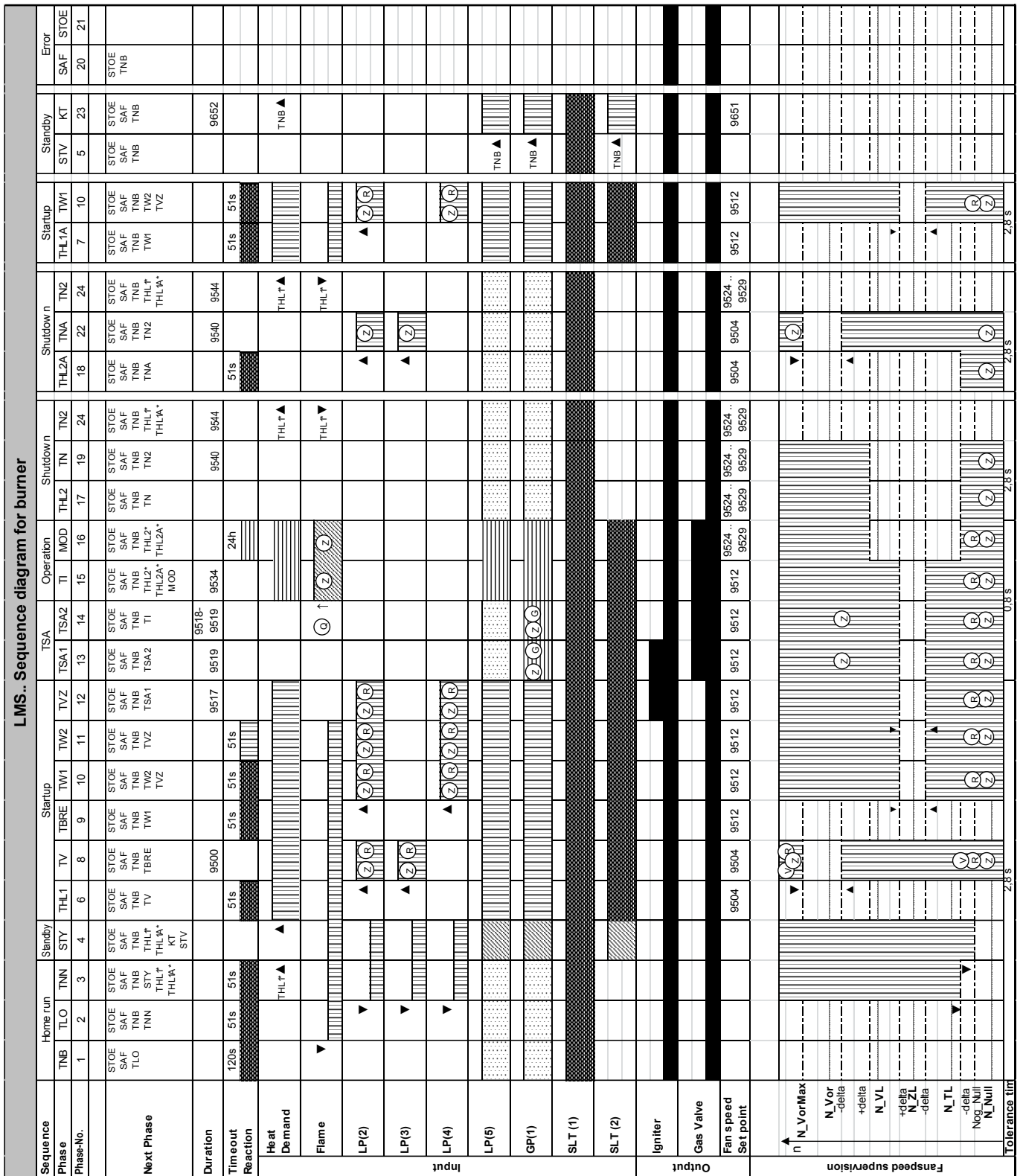

8.4 Ignition Controller Check.

1. With the burner firing, the flame signal should be at least 3 μ A. Refer to **separate Navistem manual**, HHL part no. 500001310. To check for correct operation of the ignition controller, close the gas valve. The boiler should shutdown after approximately one second and attempt a re-ignition. Check that the flame has been extinguished

2. Alternatively, the flame probe lead can be removed from the end of the flame probe, with the same result.

8.5 Gas Supply Pressure Check.

1. When the boiler modules have been checked for correct operation the gas supply pressure should be checked. This should be done with all modules firing.

- For Natural Gas, a nominal gas inlet pressure of 20mbar measured at the rear of the boiler is required, with a maximum inlet pressure of 25mbar.
- For LPG, a nominal gas inlet pressure of 37mbar measured at the rear of the boiler is required, with a maximum inlet pressure of 45mbar.

8.6 Combustion Checks

“The boiler modules are factory pre-set, but site checks must be done to confirm correct performance.”

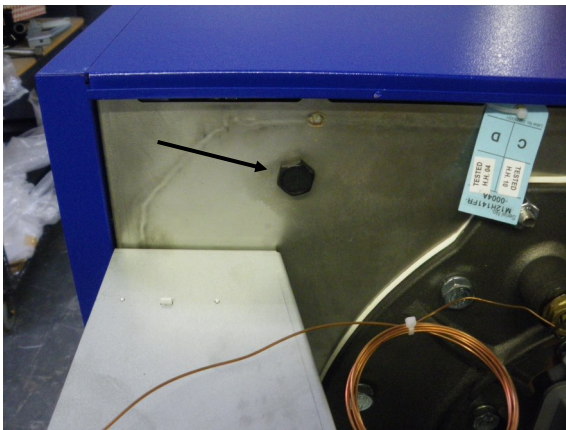

2. Use appropriate tool to remove sample point plug from front of combustion chamber (see arrow).

Figure 8.6.1 - Removal of Sample Point Plug

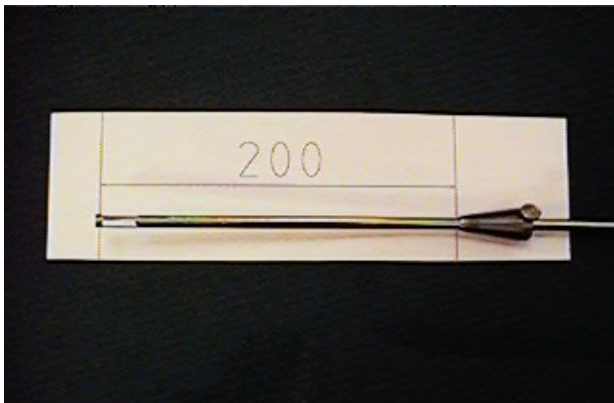

3. Ensure that an insertion distance of 200mm is set on the combustion analyser probe.

NOTE: THIS DISTANCE MUST BE SET TO ENSURE ACCURATE ANALYSIS OF FLUE GASES.

Figure 8.6.2 - Combustion Analyser Probe Setting



4. Insert probe horizontally into combustion chamber until depth stop is met.

Figure 8.6.3 - Insertion of Analyser Probe

If combustion is outside of the ranges defined below the factory sealed valves may be adjusted using the following procedure :

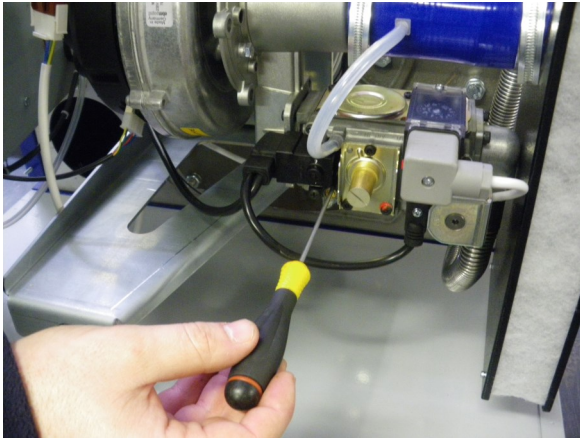

97 / 116 / 147

High Fire Target **Nat Gas - 9.0% ±0.25% CO₂**
LPG - 10.6% ±0.25% CO₂

If combustion level is outside of this range use the Throttle Screw to adjust the mixture.

THIS SETTING MUST BE CORRECT BEFORE CONTINUING To increase the CO₂ level, turn the adjustment anti-clockwise.

Figure 8.6.4 - Adjusting gas valve throttle

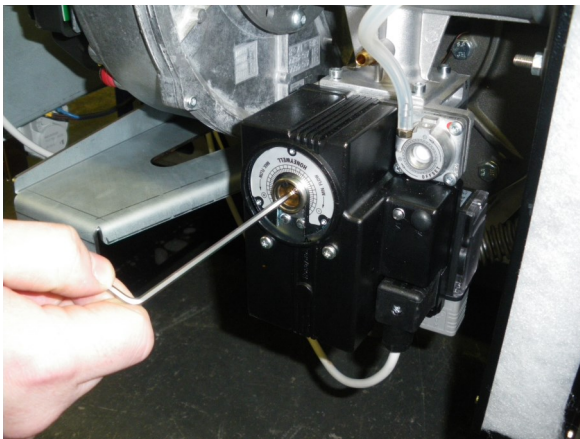

196 / 254

High Fire Target **Nat Gas 9.0% ±0.25% CO₂**
LPG - 10.6% ±0.25% CO₂

If combustion level is outside of this range use the Cross Head Throttle Screw to adjust the mixture.

THIS SETTING MUST BE CORRECT BEFORE CONTINUING To increase the CO₂ level, turn the adjustment anti-clockwise.

Figure 8.6.4 - Adjusting gas valve throttle

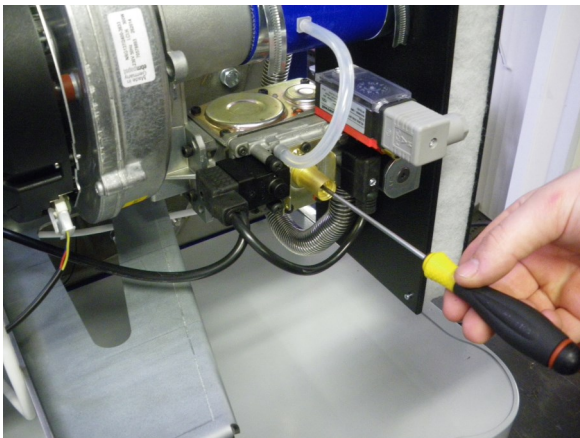

97 / 116 / 147

Low Fire Target **Nat Gas 9.0% ±0.25% CO₂**
LPG - 10.6% ±0.25% CO₂

If combustion readings are outside target range use a screwdriver to make adjustments

To increase the CO₂ level, turn the adjustment clockwise.

Figure 8.6.5—Adjusting gas valve offset



196 / 254

Low Fire Target **Nat Gas 9.0% ±0.25% CO₂**
LPG - 10.6% ±0.25% CO₂

If combustion readings are outside target range use Torx Bit to make adjustments

To increase the CO₂ level, turn the adjustment clockwise.

Figure 8.6.5—Adjusting gas valve offset

(Note: Above readings taken with front cover removed and 200mm probe insertion CO = < 60 ppm*).

5. Energise electrical supply and start the boiler module. Refer to the user instructions for the boiler input level.
6. Monitor the combustion readings on the combustion analyser at both Maximum and Minimum firing rates.

***Figure must not exceed 200ppm under normal operating conditions.**

If combustion readings fall within the required range the boiler module is set and operating correctly. If the combustion readings fall outside the required range the burner settings will require adjustment.

CONTACT HAMWORTHY HEATING TECHNICAL DEPARTMENT FOR FURTHER DETAILS

7. Shut down the boiler and isolate from the electrical supply. Remove instrumentation and replace test points and plugs.
8. Refer to **section 8.1 - Controls Operation**, to adjust the relevant boiler settings specific to the installation

8.7 User Instructions.

When the boiler is fully commissioned, the owner or their representative should be made aware of the lighting-up and operating instructions. A practical demonstration should be given describing each functional step. This Installation and Commissioning guide, the servicing instructions manual and the user's instructions should then be handed over and be kept in a safe place for future reference.

9.0 FAULT FINDING

The Wessex ModuMax boiler is equipped with full self-diagnostic fault indication, with faults being allocated a code. A lockout will be denoted by a flashing LED on the fascia panel which will also be constantly illuminated by a block error - refer to **the separate Navistem manual**.

The common fault codes are detailed in **the separate user instructions guide**. Fault codes not detailed in this manual should only be investigated by an Engineer.

Should a fault code appear which cannot be reset, or a fault code repeatedly occurs, contact Hamworthy Heating for assistance. Do not continue to operate or use the boiler as this may cause damage to the controls.

9.1 Safety Temperature Limiter (Limit Thermostat)

1. The electronic control thermostat has several safety levels built in such that a controlled shutdown should occur before the safety temperature limiter is activated. Should these safety levels be overridden (say external pump overrun failure after shutdown) the safety temperature limiter will trip initiating a boiler shutdown, preventing the boiler from firing. A code on the controls display will flash indicating that the safety temperature limiter has tripped.
2. The limit thermostat (mounted on the control panel assembly - visible after removing the front cover) will automatically reset after the boiler returns to a normal operating temperature.
3. Always carry out an investigation to ascertain the reason for overheating. The most common cause of overheating lack of water flow rate through the boiler - possibly due to external pump problem.

9.2 Ignition Controller

1. The flame is under constant supervision by the burner ignition controller. The controller monitors the flame's ability to rectify an AC current. If the flame diminishes for whatever reason and the rectified current drops below the controller's minimum detection current (3µA DC), the controller will de-energise the gas control valve within 1 second and commence a restart. Failure to establish and detect a flame during the light-up sequence will result in burner shutdown and lockout within 5 seconds, requiring a manual reset to restart the ignition sequence.
2. If the boiler continues to lockout, then an investigation must be made to ascertain the cause.
3. A false flame signal at the start and during pre-purge will cause the boiler module to restart its ignition sequence at the end of the pre-purge period. If this occurs 3 times in succession the controls will disable operation of the boiler module, requiring reset of the module.

Figure 9.3- Wiring Diagram

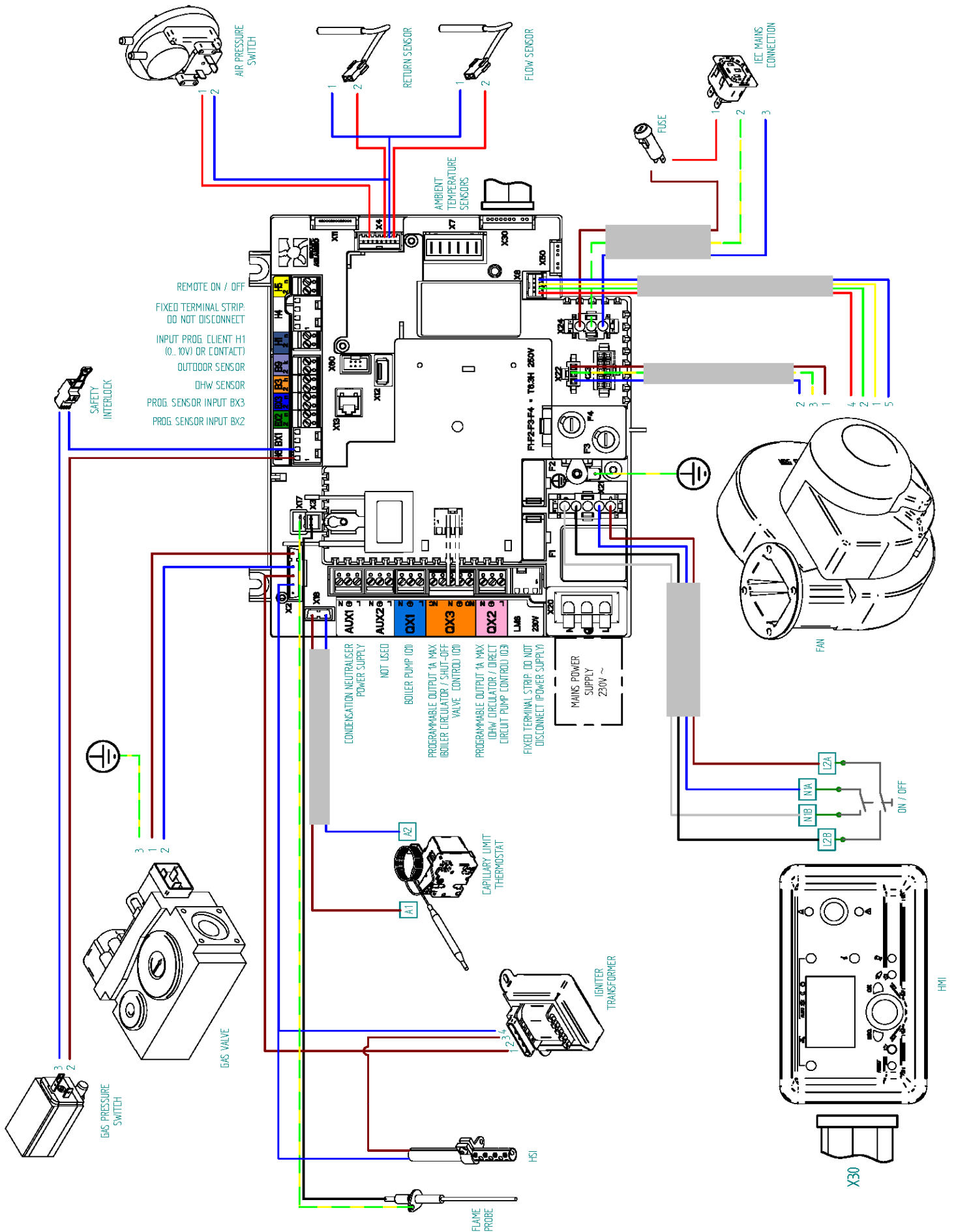

10 SERVICING

A competent person registered for working on non domestic gas appliances should check and ensure that the flue, its support and terminal, the ventilation to the boiler house, safety valve, drain, water filter if fitted, pressure gauge, etc.; are in a serviceable and working condition and still comply with the relevant standards and codes of practice - see **Section 4**.

10.1 Regular servicing is recommended, preferably by a Hamworthy appointed person, and at least annually, to ensure trouble free operation.

For Wessex ModuMax, Hamworthy would recommend an additional 6 monthly examination following commissioning, acknowledging site conditions and running hours.

Although cleaning of flue ways may not be necessary on a yearly basis, it is important that all controls and safety features are checked for correct operation.

Note:- Measuring flue gas CO₂ and gas temperatures will give an indication of the state of the boiler flue ways and waterways. Results should be compared with previously measured values to establish possible loss of efficiency.

Should remedial work be carried out on a module, then the non-firing module must be electrically isolated so as to prevent accidental operation in the event that the installation is required for ongoing heating requirements.

10.2 Annual Service

The procedure detailed relates to a single module and **MUST** be carried out on ALL individual modules which constitute a unit. Before servicing the boiler, the following procedure must be carried out :-

WARNING: Isolate all electrical supplies and turn off the gas service valve.

- 1) Remove the front casing door by unscrewing the centre fixing.
- 2) Disconnect the H.S.I. and flame probe connectors from the respective probes. Remove the earth lead from the flame probe.
- 3) Disconnect the fan power supply and control leads from the fan taking care with the latch on each connector.
- 4) Check that the gas service valve is closed, then undo the lower connection union on the flexible hose (at gas service valve connection).
- 5) Carefully remove the electrical plug from the gas valve and remove the Low Gas Pressure Switch.
- 6) Remove the air inlet filter cassette. Refer to section 11.15
- 7) Remove the 2 M8 burner retaining nuts and carefully withdraw the complete burner/ fan assembly from the

heat exchanger. Separate the burner fabrication from the fan, venturi and gas control valve .

8) Remove and inspect H.S.I. and flame probe, ensure they are free from debris or deposits. Test resistance value of H.S.I. & if above 200 ohms (cold), replace with a lower resistance unit. Check respective positions – See Figure 10.2.

Note:- The H.S.I. element is very fragile.

9) Check the burner and clean using a soft brush if required (if possible use a vacuum cleaner to remove the dust from inside the burner tube). After cleaning the inside, the burner tube can be washed using clean water. Tap the burner flange firmly downwards on a block of wood to dislodge any residual debris from inside the burner tube. A damaged or cracked burner should be replaced.

Note:- Do not use a wire brush to clean the burner.

10) Check and clean the filter medium by washing in warm soapy water. **DO NOT OPERATE THE BOILER WITH THE FILTER REMOVED!**

11) Separate the gas valve from the venturi & ensure venturi mouth and gas feed tube are clean and free of obstruction.

12) Inspect the fan scroll and impellor, clean and check for damage.

13) Inspect the non return valve in the burner inlet duct for smooth operation. If venturi is removed it must be put back in exactly the same position.

14) Separate the inlet flange and elbow fitting from the gas control valve by removing the 4 M5 socket cap head screws. Check that the mesh inlet filter in the gas valve is clear of debris, remove any foreign objects caught in the filter.

Re-assemble in reverse order taking care to inspect and if necessary, replace any o-rings, gaskets or seals.

Refer to **Section 8.4 onwards, Commissioning and Testing**, and test all gas joints broken or disturbed for soundness before firing.

Carry out a combustion check by testing the flue gas CO₂ and CO levels as detailed from **Section 8.4**.

10.3 Four Year Service

Repeat the annual service as previously described but do not refit any components to the heat exchanger.

10.3.1 To clean the heat exchanger, the use of a high pressure water hose (40-80 psi) is recommended. However provision must be made for the drainage of water used in this process. At the rear of the boiler module remove the condensate drain trap assembly

Figure 10.2 - Hot Surface Igniter and Flame Sensing Probe Positions

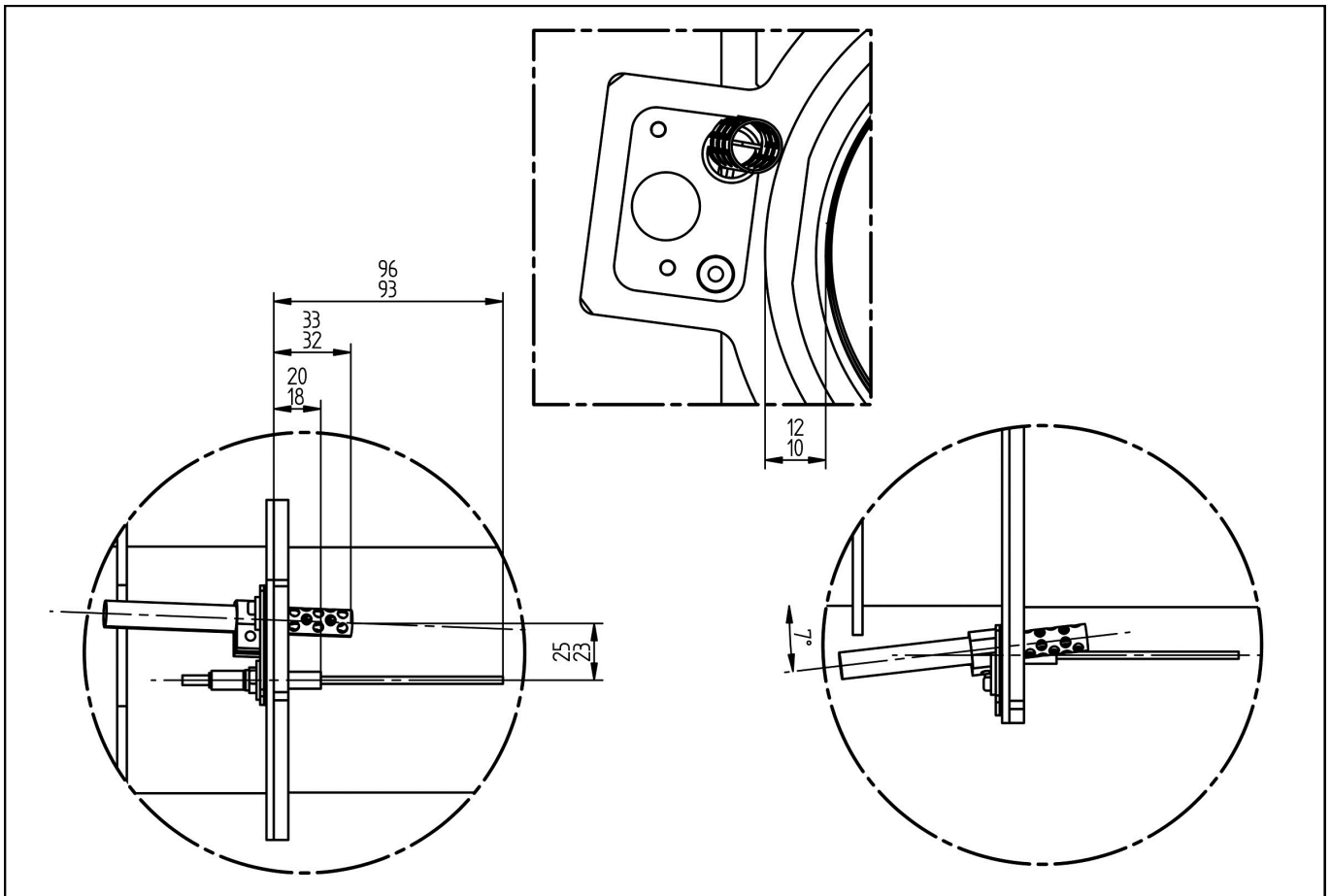

from the casing by unfastening the 2 M6 nuts, to expose the opening in the casing. The cleaning water and any debris will exit the casing through this opening. On completion ensure that the opening is clear of debris and refit the condensate drain trap assembly, renewing the gasket if required.

10.3.2 Should a high pressure hose not be available, the heat exchanger will have to be removed from the module casing. Isolate the heat exchanger from the flow and return water pipework and drain down. Remove all fittings from the water flow and return connections (including sensors and pockets) and remove the safety valve (if fitted) or $\frac{3}{4}$ " cap. Unfasten the 10 M8 nuts securing the water connection sealing plates and the safety valve pipe sealing plate, and remove all sealing plates and o-rings.

The boiler heat exchanger assembly is heavy, 97 & 116 weigh 100kg each & 147/196/254 weigh 130kg. It is recommended that a suitable lifting apparatus is used to support the weight of the heat exchanger, an M12 lifting eye nut can be fitted to the M12 stud at the top of the heat exchanger front plate for this purpose. Before connecting the lifting equipment to the lifting eye, hang a new heat exchanger to casing sealing gasket over the lifting eye, with the adhesive side facing the boiler. This will enable the new gasket to be fitted on re-assembly without cutting it!

Remove the 6 M10 nuts that retain the heat exchanger

into the boiler module casing, and with the front end supported slowly withdraw the heat exchanger until the rear of the stainless steel baffles are visible. With the rear of the heat exchanger resting in the body of the boiler and the front supported by the lifting apparatus, access is gained for removal of the stainless steel baffles. The silicon sealant between the baffle and the end plates must be peeled away, before attempting to remove the baffles. Unhook the stainless steel springs and remove the baffle plates to expose the finned tube bank. Wire brush both sides of the baffles to remove any deposits. Thoroughly wire brush the finned tubes and ensure that all debris is removed from the centre of the heat exchanger.

Remove the heat exchanger from the boiler body. The heat exchanger tubes are stainless steel. Remove the bolts and nuts securing the heat exchanger front cover plate. Remove the bolts securing the heat exchanger rear cover plate. Clean and de-scale all surfaces of the heat exchanger tube header castings and cover plates, and internal surfaces of the finned tubes and water connection nipples. Chemical de-scaling is preferred for the tube bank assembly.

Note: Always follow the chemical manufacturer's instructions to ensure correct application and safety.

Re-assemble the baffle plates by fitting one of the stainless steel springs and inserting the baffles beneath it, then fitting the second spring. When all the baffles are

in place the gap between the ends of the baffle and the end plates must be sealed with silicon sealant. Remove the existing heat exchanger to casing sealing gasket and fit the new gasket previously hung on the lifting eye. Clean mating surfaces of the heat exchanger tube header castings and cover plates. Re-assemble the heat exchanger assembly using new gaskets.

Ensure that the cover plates are re-fitted in the correct orientation. Evenly torque the bolts and nuts to 7kg m.

Refit heat exchanger ensuring correct rotational orientation, so that the water connection nipples and safety valve pipe pass through the holes in the rear of the casing, fastening in place with the 6 M10 nuts. Refit the water connection and safety valve pipe sealing plates, renewing all gaskets and o-rings. Reconnect the system pipework and check for soundness.

Ensure that the cover plates are re-fitted in the correct orientation. Evenly torque the bolts and nuts to 7kg m.

Re-fit the burner assembly. **Test all gas joints broken or disturbed for soundness before firing.**

Refer to **Section 8 Commissioning The Boiler**, for correct procedures.

11.0 REPLACEMENT OF FAILED COMPONENTS

There are a number of components listed below which can be replaced simply and quickly by following the given procedure. In each case the operation of each replaced component must be checked by carrying out the appropriate part of the commissioning procedure. See **Section 8: COMMISSIONING & TESTING**.

Note:- Isolate all electrical supplies to the boiler module before removing the front cover and commencing any servicing or component exchange procedure. With the front cover removed, turn off the gas supply at the service valve.

11.1 Hot Surface Igniter and Flame Probe Assembly Part Nos. 563801019 & 533805021

Note:- The igniter and flame probe ceramics are very fragile.

Unplug the igniter from the harness, remove the single socket cap head screw securing the igniter to the burner flange and withdraw the igniter. When fitting the replacement carefully feed the igniter through the mounting hole and secure with the socket cap head screw.

Flame Probe - The only maintenance which can be carried out is to clean the wire of any deposits with an abrasive paper, taking care not to damage the electrode. A typical flame current is 10µA, (high fire) with the lockout threshold at 3µA, Disconnect the flame probe lead & earth lead, remove the single socket cap head screw securing the probe to

the burner flange and withdraw the probe. When fitting the replacement carefully feed the probe through the mounting hole taking care not to damage the ceramic.

Note:- Do not remove both securing screws at the same time as the separate flange and Mica sight glass will become detached.

Ensure the positions of the igniter and probe are as recommended in Figure 10.2.

11.2 Flow / Return sensor Part No. 533901431

The two identical sensors are located in pockets on the flow and return pipes at the rear of the boiler. To remove the sensor, unplug the sensor from the harness, loosen the M3 screw securing the sensor in the pocket and withdraw the sensor.

Upon replacement ensure that the sensor is fully engaged and secured into the pocket.

11.3 Temperature Limiter (Limit Stat) Part No. 531040016

To replace the limiter, remove the boiler front cover to expose the control panel assembly. Remove the electrical connections from the limiter body noting the position of the coloured cables. Unclip and remove the thermostat bulb from the pocket in the front of the heat exchanger. Undo the 2 fixing screws in the front of the control panel and remove the unit.

Check the operation of the replacement device by carefully applying a heat source to the bulb. The temperature of the replacement limit stat is factory set and will not require adjustment.

Fit the replacement limiter in reverse order ensuring that the electrical connections are in the correct positions.

11.4 Gas Valve Part No. 533903044 (97, 116 & 147) Part No. 533903036(196 & 254)

Note:- Some gas valve components can be replaced without completely removing the whole assembly from the boiler. However, Hamworthy Heating strongly recommend that a complete new gas valve is fitted to ensure safe, reliable operation of the boiler. Please refer to Hamworthy Heating Technical Department before attempting to remove components from the gas valve.

Ensure that the boiler module electrical power and gas supplies are isolated. Unfasten the gas valve plug securing screws and disconnect the plug by pulling firmly away from the valve. Unfasten the low gas pressure switch plug and remove the low gas pressure switch from the gas valve (97/116/147 only) by removing the securing screw.

Remove the 4 M5 cap head screws securing the gas valve to the gas inlet flange, allow the flange to hang

free on the flexible gas pipe. Remove the 4 M5 cap head screws securing the gas valve to the gas feed pipe, taking care to support the weight of the valve. Note that the cap head screws are different lengths at the inlet and outlet of the valve, be sure to replace at the correct positions.

Replace the gas valve complete with new 'O' rings, ensuring correct orientation - gas flow is in the same direction as the arrow marked on the valve. Replace the LPG orifice, if fitted. Replace the gas valve leads, ensuring correct plug positions and orientation, and secure firmly with the retained screws.
Refit the low gas pressure switch (97/116/147 only) and secure the electrical plug with the retaining screw.

Check the setting of the gas supply pressure switch, and adjust if necessary. Unfasten the single pozi pan head screw to remove the cover if adjustment is required. Replace the cover after setting the switch to **97/116/147** - 7mb
196/254 - 7.5mb

Switch on the boiler module gas supply and check for integrity of all joints using a proprietary leak detector. Refer to Figure 7.1 if necessary for valve integrity check procedure. Switch on the boiler module electrical power supply and ensure gas valve operation is correct and safe before continuing.
Re-light the boiler module. For correct settings and procedures refer to **Section 8.0 Commissioning The Boiler**.

11.5 Combustion Fan

Part No. 533704014 - (97/116/147)

Part No. 533704003 - (196/254)

Ensure that the boiler module electrical power supply is isolated before removing the front cover and gaining access to the controls.

97/116/147

Disconnect the fan power supply and control leads from the fan.

Remove the 3 M6 hex head screws, nuts and washers fastening the venturi to the gas valve. Remove the 4 M5 screws securing the fan outlet to the burner flange and remove the fan.

196/254

Disconnect the fan power supply and control leads from the fan. Separate the venturi and gas control valve from the fan by unfastening the 6 M8 socket dome head screws. Make provision to support the weight of the venturi and gas control valve whilst not connected to the fan.

Remove the 4 M8 hex head screws, nuts and washers fastening the fan to the burner and remove the fan.

Fit the replacement in reverse order, and if required replace any seals or gaskets.

Note:- After re-making any gas or combustion circuit joint/connection, an integrity check is recommended to ensure safety.

11.6 Venturi

Part No. 532418007 - (97/116/147)

Part No. 532418001 - (196/254)

Ensure that the boiler module electrical power supply is isolated before removing the front cover and gaining access to the controls. Isolate the boiler module gas supply by closing the gas service valve.

Remove the 4 M5 socket cap head screws from the venturi gas inlet flange and separate the gas control valve from the venturi. Make provision to support the weight of the valve assembly whilst not connected to the venturi. Separate the venturi from the fan by unfastening the 6 M8 socket dome head screws.
Fit the replacement in reverse order, and if required replace any seals or gaskets.

11.7 Burner

Part No. 533301019 - (97 & 116)

Part No. 533301020 - 147

Part No. 533301021 - 196

Part No. 533301024 - 254

Disconnect the H.S.I. and flame probe connectors from the respective probes. Disconnect the fan power supply and control leads from the fan taking care with the latch on each connector.

Unscrew retaining screws and remove the electrical plugs from the gas valve and low gas pressure switch.

97 & 116

Check that the gas service valve is closed, then undo the lower connection union on the flexible hose (at gas control valve inlet elbow). Separate the burner fabrication from the fan .

147/196/254

Undo the lower connection union on the flexible hose (at gas control valve inlet elbow). Remove the 2 M8 burner retaining nuts and carefully withdraw the complete burner assembly from the heat exchanger. Separate the burner fabrication from the fan, venturi and gas control valve.

Note the assembly of the non return valve in the burner inlet duct. Inspect the non return valve for smooth operation.

Remove and inspect H.S.I. and flame probe, ensure they are free from debris or deposits. Test resistance value of H.S.I. if above 200 ohms (cold), replace with a lower resistance unit. Check respective positions – See Figure 13.2.

Note:- The H.S.I. element is very fragile.

A damaged or cracked burner should be replaced.

Replace components in reverse order using new gaskets.

11.8 Ignition Transformer

Part No. 533901441

Ensure that the boiler module electrical power supply is isolated before removing the front cover and gaining access to the controls.

Unplug the electrical connections to the transformer noting the orientation and relative positions. Remove the two pozi pan head screws securing the transformer to the control panel and withdraw. Fit the new unit in reverse order. Re-light the boiler and check for correct operation.

11.9 Main Control - Navistem

<u>Part Number</u>	<u>Model</u>
533901756	- WM97
533901758	- WM116
533901760	- WM147
533901762	- WM196
533901764	- WM254

Ensure that the boiler module electrical power supply is isolated before removing the front cover and gaining access to the controls. Also ensure that all other supplies, particularly to the volt free contact outputs, are also isolated.

If a 'Clip in Module' is fitted, this must first be removed. Carefully disconnect the plug securing the clip-in to the Navistem. Depress the locking latch at the connector end of the clip in to allow the module to be hinged up and disengaged from the Navistem.

Unplug the electrical connections to the PCB noting the orientation and relative positions.

Fit the replacement PCB in reverse order as described above. Remember to apply the parameters local to the installation on initialisation - refer to the separate Navistem manual. Re-light the boiler and check for correct operation.

11.10 Clip in Modules

Part No. 533901776- Extension module

AGU2.550A109

Part No. 533901456 - LPB module

OCI345.06/101

Ensure that the boiler module electrical power supply is isolated before removing the front cover and gaining access to the controls.

Carefully disconnect the plug securing the clip-in module to the Navistem

Carefully disconnect the plug from the top of the clip-in module.

Depress the locking latch at the connector end of the clip in to allow the module to be hinged up and disengaged from the Navistem or control panel. Assemble in reverse order.

11.11 Display screen

Part Number 533901691

Ensure that the boiler module electrical power supply is isolated before removing the front cover and gaining access to the controls.

Carefully disconnect the ribbon cable connecting the screen to the Navistem controller and the connectors to the power switch. Remove the 4 screws securing the screen panel to the controls pod. Unclip the screen from the panel of the controls fascia and remove the display pcb.

Remove the ribbon cable plug from the pcb and replace the display in reverse order.

11.12 Low Gas Pressure Switch

Part No. 533901497 - 97/116/147

Part No. 533925004 - 196/254

Ensure that the boiler module electrical power supply is isolated before removing the front cover and gaining access to the controls.

Isolate the boiler module gas supply by closing the gas service valve.

97/116/147

Disconnect the electrical plug after removing the securing screw. Remove the switch securing screw and withdraw the switch from the Brass adaptor. Fit the replacement switch in reverse order using new 'O' rings.

196/254

Disconnect the electrical plug after removing the securing screw. Remove the screw(s) securing the switch to the gas valve body.

Fit the replacement switch in reverse order using new 'O' rings.

Set to correct pressure - refer to Appendix A.

11.13 Air Pressure Switch

Part Number 532496004

Ensure that the boiler module electrical power supply is isolated before removing the front cover and gaining access to the controls.

Disconnect the sensing tube from the switch (P1) noting the position. Disconnect the electrical connections (1&2) noting their position. Remove the 2 screws securing the pressure switch body to the control bracket and remove the switch. Fit the replacement unit in reverse order.

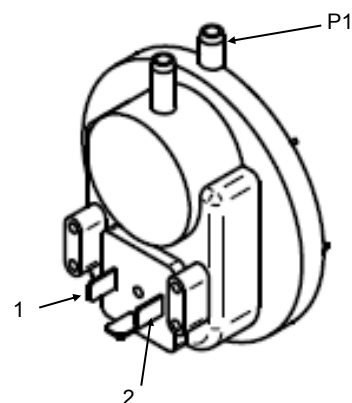

**11.14 Ignition Transformer In-line Fuse
Part No. 533922013**

The boiler is equipped with an in-line fuse fitted between the ignition transformer and the main LMS. This T1A rated fuse can be located on the control panel once the front cover is removed. The condition of the fuse should be checked when a possible LMS malfunction has been diagnosed.

Fig. 11.14 In-line Fuse

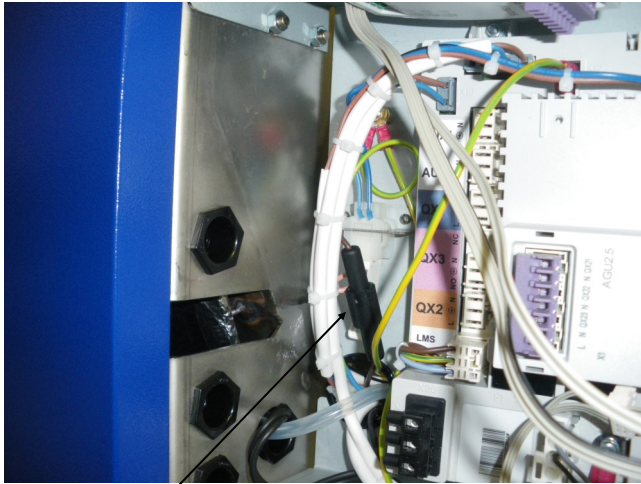

In-Line Fuse

**11.15 Air Inlet Filter
Replacement Filter Material Part No. 532812016**

The ModuMax mk3 is fitted with an air inlet filter which is accessed after removing the main front cover of the boiler. The White filter material can be replaced at service intervals by ordering the part number above available from Hamworthy Heating Ltd spares department. Remove the retaining pin from the top corner of the filter and replace with the new, clean material. Replace the retaining pin.

Fig. 11.15 Air Filter

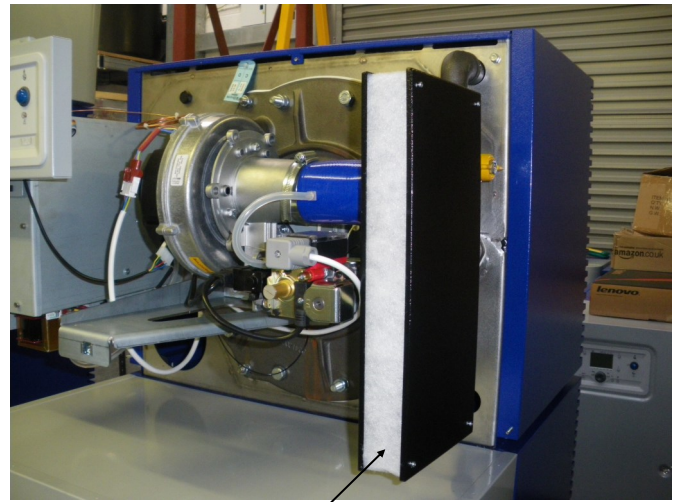

Air Filter Media

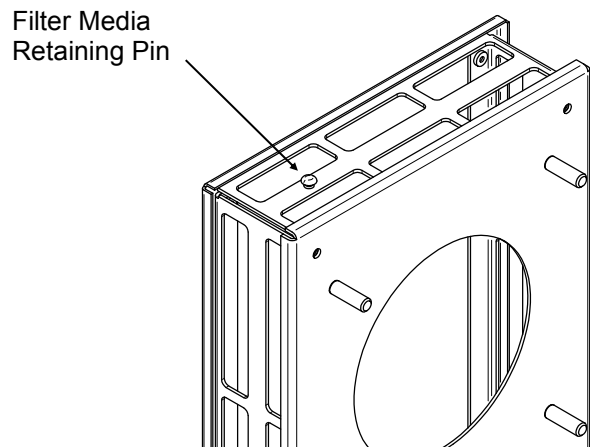

12.0 RECOMMENDED SPARES

Please Note:- To ensure the correct spare parts are despatched by our spares department, it is imperative that the complete Boiler/Module/Control Panel Serial Numbers are given. The Boiler and Module Serial Numbers are located on the Data Plates affixed to the combustion chamber front panel. The Electrical Serial Number is located inside the Control panel on the maximum power rating label. These numbers **MUST** be quoted when ordering spare parts.

SPARES ITEM	PART No.
ELECTRICAL ITEMS	
Navistem controller - 97	533901756
Navistem controller- 116	533901758
Navistem controller - 147	533901760
Navistem controller - 196	533901762
Navistem controller - 254	533901764
Navistem control panel	533901691
Ignition Transformer	533901441
Flow / Return Sensor	533901431
Temperature Limiter.....	531040016
Hot Surface Igniter	563801019
Flame Sensing Probe	533805021
Clip in Module - AGU2.511A109.....	533901776
Clip in Module - LPB Bus communication - OCI345.06/101	533901777
T1A Fuse 5x20	533922013
MECHANICAL ITEMS	
Burner Fabrication - 97 & 116.....	533301019
Burner Fabrication - 147.....	533301020
Burner Fabrication - 196.....	533301021
Burner Fabrication - 254.....	533301024
Gas Control Valve - 97/116/147	533903044
Gas Control Valve - 196/254.....	533903036
Combustion Fan - 97/116/147	533704014
Combustion Fan - 196/254	533704003
Venturi - 97/116/147	532418007
Venturi - 196/254	532418001
Low Gas Pressure Switch - 97/116/147	533901497
Low Gas Pressure Switch - 196/254	533925004
Gas Orifice (LPG models 196/254 only).....	531101013
Air Pressure Switch.....	532496004
Descale Kit (condensing models).....	563605560
Gasket - Burner to heat exchanger	531201078
Gasket—Fan to burner	531201071
Gasket—View port	531201066
View Port Sight Glass	539907001
Air Filter Media.....	532812016
For service or spares please contact :-	
Hamworthy Heating Limited	Phone Number..... 01202 662500
Wessex House	Fax Number..... 01202 662522
New Fields Business Park	Service..... 01202 662555
Stinsford Road	Spares..... 01202 662525
Poole, Dorset BH17 0NF	Technical..... 01202 662505

APPENDIX A - GAS DATA

GENERAL DATA	BOILER MODEL					
	97/97		97/194		97/291	
Model - Condensing	Nat Gas	LPG	Nat Gas	LPG	Nat Gas	LPG
Boiler Input (maximum) - kW (Gross)	109.0	106.7	218.0	213.4	327.0	320.1
Boiler Input (maximum) - kW (Nett)	98.2	98.2	196.4	196.4	294.6	294.6
Boiler Output kW (maximum) condensing 50/30°C - kW	97.2	97.2	194.4	194.4	291.6	291.6
Boiler Output kW (maximum) non condensing 80/60°C - kW	95.7	95.7	191.4	191.4	287.1	287.1
Boiler Module Output (minimum) 80/60°C kW	19.1					
Model - Condensing	116/116		116/232		116/348	
	Nat Gas	LPG	Nat Gas	LPG	Nat Gas	LPG
Boiler Input (maximum) - kW (Gross)	133.0	130.2	266	260.4	399	390.5
Boiler Input (maximum) - kW (Nett)	119.8	119.8	239.6	239.6	359.4	359.4
Boiler Output kW (maximum) condensing 50/30°C - kW	116.2	116.2	232.5	232.5	348.7	348.7
Boiler Output kW (maximum) non condensing 80/60°C - kW	115.2	115.2	230.4	230.4	345.6	345.6
Boiler Module Output (minimum) 80/60°C - kW	23.5					
Model - Condensing	147/147		147/294		147/441	
	Nat Gas	LPG	Nat Gas	LPG	Nat Gas	LPG
Boiler Input (maximum) - kW (Gross)	163.0	159.5	326	319.1	489	478.6
Boiler Input (maximum) - kW (Nett)	146.8	146.8	293.6	293.6	440.3	440.3
Boiler Output kW (maximum) condensing 50/30°C - kW	147.4	147.4	294.8	294.8	442.2	442.2
Boiler Output kW (maximum) non condensing 80/60°C - kW	142.8	142.8	285.6	285.6	428.4	428.4
Boiler Module Output (minimum) 80/60°C - kW	28.7					
Model - Condensing	196/196		196/392		196/588	
	Nat Gas	LPG	Nat Gas	LPG	Nat Gas	LPG
Boiler Input (maximum) - kW (Gross)	219.0	214.4	428.7	394.4	657	643.1
Boiler Input (maximum) - kW (Nett)	197.2	197.2	394.4	394.4	591.6	591.6
Boiler Output kW (maximum) condensing 50/30°C - kW	196.3	196.3	392.6	392.6	588.9	588.9
Boiler Output kW (maximum) non condensing 80/60°C - kW	191.6	191.6	383.2	383.2	574.8	574.8
Boiler Module Output (minimum) 80/60°C - kW	38.6					
Model - Condensing	254/254		254/508		254/762	
	Nat Gas	LPG	Nat Gas	LPG	Nat Gas	LPG
Boiler Input (maximum) - kW (Gross)	275.0	269.2	550	538.3	825	807.5
Boiler Input (maximum) - kW (Nett)	247.6	247.6	495.3	495.3	742.9	742.9
Boiler Output kW (maximum) condensing 50/30°C - kW	254.4	254.4	508.7	508.7	763.1	763.1
Boiler Output kW (maximum) non condensing 80/60°C - kW	239.8	239.8	479.6	479.6	719.4	719.4
Boiler Module Output (minimum) 80/60°C - kW	48.4					
GAS DATA	97	116	147	196	254	
Gas Inlet Connection Pipe Thread Size	R1"		R1 1/4"			
Nominal Inlet Pressure Nat Gas (LPG) -mbar	20 (37)					
Maximum Inlet Pressure Nat Gas (LPG) -mbar	25 (45)					
Gas Pressure Switch Setting Nat Gas -mbar	7	7	7	5	5	
Gas Flow Rate (max. per module) Nat Gas -m ³ /h	10.4	12.7	15.5	20.9	26.2	
Gas Flow Rate (max. per module) LPG -m ³ /h	4.0	4.9	6.0	8.1	10.1	
Target CO ₂ % at High / Low fire Nat Gas ±0.25%	9.0					
Target CO ₂ % at High / Low fire LPG ±0.25%	10.6					
NO _x emission at 0% O ₂ (dry) Nat Gas mg/kWh	39.8	34.3	37.7	39.9	38.8	
NO _x emission at 0% O ₂ (dry) LPG mg/kWh	42.0	58.1	69.3	68.6	39.9	

DATA ON PRODUCTS ≤ 400kW

PRODUCT REFERENCE						
Trade mark		Modumax				
Models		97	116	147	196	254
Nominal power	Prated kW	97	116	147	196	254
At nominal power and in 80°C/ 60°C regime	P4 kW	95.7	115.2	142.8	191.6	239.8
	N4 (Gross) %	87.7	86.5	87.5	89.0	87.4
At 30% nominal power and in 30°C return temperature regime	P1 kW	29.1	36.0	44.1	58.8	76.2
	N1 (Gross) %	96.6	94.6	96.6	95.0	96.8
Auxiliary electricity consumption						
Under full load	elmax kW	0.072	0.072	0.151	0.252	0.252
Under partial load	elmin kW	0.043	0.043	0.045	0.151	0.151
In standby mode	PSB kW	0.005	0.005	0.005	0.005	0.005
Other properties						
Heat Loss	Pstby kW	0.19	0.19	0.22	0.22	0.22
Nitrogen oxide emissions	Nox (Gross) mg/kWh	40	40	38	40	38

APPENDIX B - ELECTRICAL CONNECTIONS AND CONTROLS

ELECTRICAL DATA		
Model	97/97 116/116	147/147 196/196 254/254
Normal Supply Voltage	230V ~ 50Hz	
Power Consumption (maximum per module) -W	166	240
Maximum Current (per module) -A	0.72	1.05

B1.1 Electrical Supply

IMPORTANT: Individual boiler modules must be earthed.

The boiler must be isolated from the mains electricity supply in the event of electric arc welding being carried out on any connecting pipework.

1. Wiring external to the boiler must be installed in accordance with the IEE Regulations and any local regulations which apply. Wiring must be completed in heat resistant cable of 1.0mm² cross sectional area. Boilers are normally supplied for connection to a 230 volts, 50Hz mains supply. The Navistem is supplied with a replaceable fuse (T6.3A). External fuses should be 10A for all boiler modules.
2. 3-Phase Electrical Supplies. Individual modules of ModuMax boilers and boilers installed in close proximity to each other **MUST NOT** be supplied from different phases of a 3 phase supply. The method of connection to the mains electricity supply must facilitate complete electrical isolation of the single boiler / battery with a separation of at least 3mm in all poles.
3. A mains isolator must be provided adjacent to the boiler in a readily accessible position. The supply should only serve the boiler using the conduits supplied. High and low voltage cables should be separated and routed along individual conduits.
4. 2 & 3 high stacked modules. It is highly recommended that each boiler module is connected via its own mains isolator to facilitate servicing and maintenance of the individual boiler modules whilst leaving the remaining modules in operation. For typical schematic please refer to figure B1.2 on the next page.
5. Volt free contact electrical supplies must be isolatable where fitted.
6. Further details regarding connection to the electricity supply are given in BS EN 60335, Part 1 or BS 3456, Part 201.

WARNING: THE MAINS POWER SUPPLY MUST NOT BE SWITCHED BY A TIME-CLOCK CONTROL.

CAUTION: DO NOT FEED MAINS VOLTAGE ONTO THE TIMER TERMINALS

7. The mains power supply must be maintained at all times. Each Wessex ModuMax boiler module incorporates a remote stop/start loop, which can be used to operate the boiler(s) under a timed regime. The boiler controls provide a 24V DC signal that can be fed through a volt free contact for operation. Refer to BS 6644 for further information on installing the electrical supply.

**NOTE:
FOR ELECTRICAL CONNECTIONS TO BOILER SEE FIGURE 4.6
FOR BOILER WIRING SCHEMATIC SEE FIGURE 9.3.2
FOR MULTIPLE BOILER WIRING SEE FIGURE B1.2
FOR CONTROL WIRING SEE FIGURE E1.3.1 TO E1.3.3**

Figure B1.2 - External Control Wiring for Multiple Module Installation

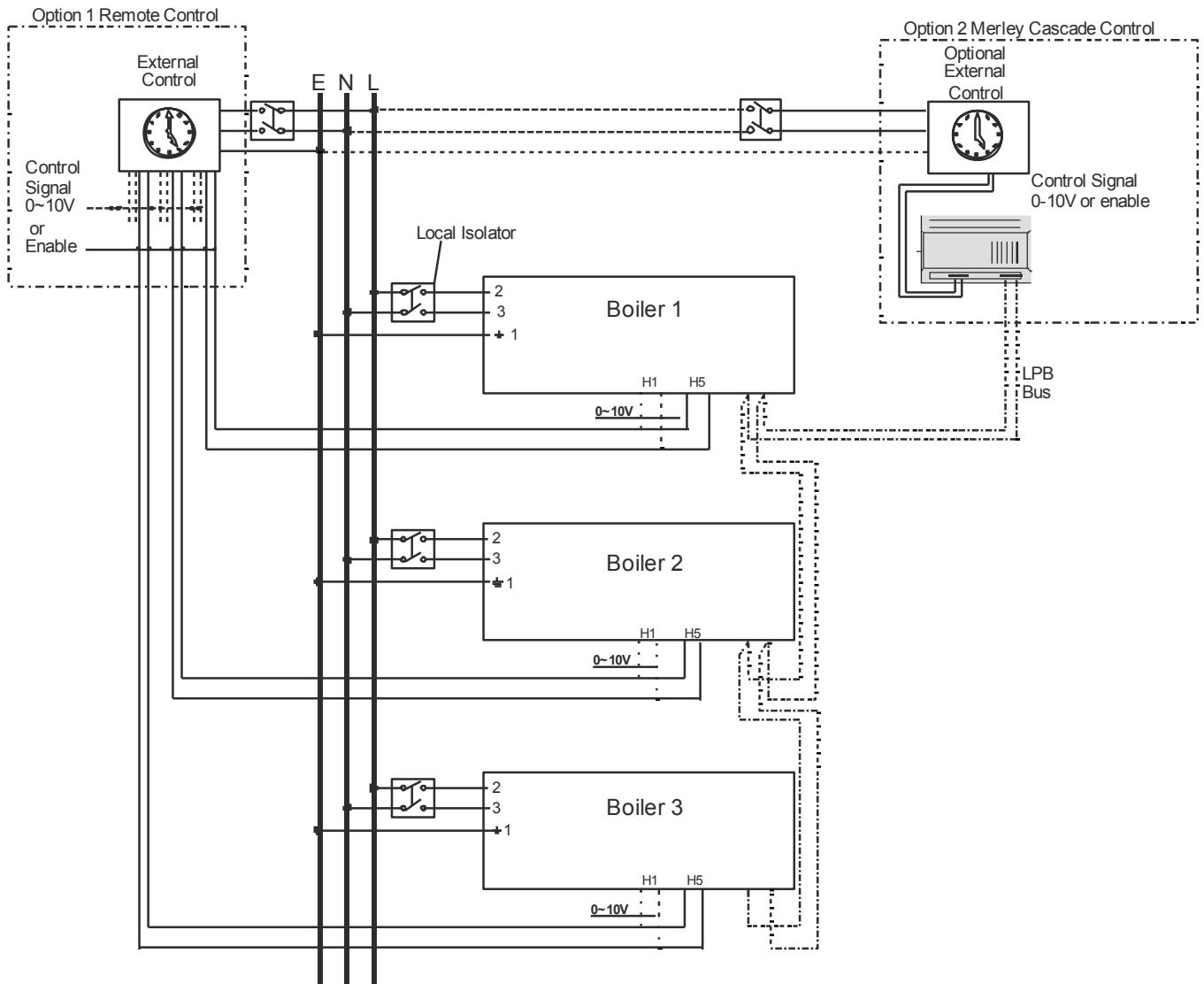

Note:- each module requires independent isolation of electrical supply and control signals. Signal cables must not be run in the same conduit as mains voltage cables

- Option 1 - reference should be made to Building Regulations and CIBSE Guide 'Energy Efficiency in Buildings' for controls requirements. All modules must be sequenced.
- Enable - will give On/Off control of the modules
- 0~10V - will give modulation control of each module
- Option 2 provides modulation control of up to 16 modules.

APPENDIX C - FLUE DATA

Natural Gas & LPG

FLUE DATA - Natural Gas		97			116			147		
Model - Condensing		97	196	291c	116	232c	348c	147	291c	441c
Nominal Flue Diameter-	mm	100	180	180	100	180	180	150	250	250
Maximum Flue Gas Temperature-	°C	83			83			78		
Pressure at the boiler flue outlet-	Pa/mbar	150 / 1.5			150/1.5			150/1.5		
Approx. Flue Gas Volume	m ³ /h*	143	286	429	160	320	480	214	428	642
		196			254					
Model - Condensing		196	392c	588c	254	508c	762c			
Nominal Flue Diameter-	mm	150	250	250	150	250	250			
Maximum Flue Gas Temperature-	°C	83			82					
Pressure at the boiler flue outlet-	Pa/mbar	150/1.5			150 / 1.5					
Approx. Flue Gas Volume	m ³ /h*	279	558	837	354	708	1062			

* **Note:-** Flue gas volumes are corrected to a flue gas temperature of 15°C, @ 9.1% CO₂ and barometric pressure of 1013.25mbar.

C1.0 FLUE SYSTEM

1. Detailed recommendations for flue systems are given in BS 6644, and IGE/UP/10. All flue discharges for plant exceeding 150kW output must comply with the third edition of the 1956 Clean Air Act Memorandum.

WARNING: THE FLUE DISCHARGE FROM A MODUMAX BOILER WILL GENERATE A PLUME AT THE TERMINAL EXIT. THIS MUST BE CONSIDERED WITH REGARD TO TERMINAL LOCATION AND ADJACENT BUILDING FABRIC.

C1.1 General Requirements

The Hamworthy Wessex ModuMax series of boilers are designed to be used with natural draught flues. Flue systems should be designed in accordance with regulations and with reference to BS 6644 and IGE/UP/10.

Open (Natural draught) Flue.

Type B23: Intake from ventilated plant room and discharge via horizontal/vertical flue. – Fig C1.1.2

Type B23p: Flue pressurised, intake from ventilated plant room and discharge via horizontal/vertical flue.– Fig C1.1.2

The connection to the boiler is suitable for 100mm flue duct (97 & 116) & 150mm flue duct (147/196/254), for connection to an open flue (chimney) system . The resistance of the flue system components is detailed in Figure C1.1.1

The following points should be noted:

- Due to the high thermal efficiency of the boiler condensation in the flue will occur. It is strongly recommended that twin wall or insulated flue pipe is used on all installations.
- Care should be taken to ensure that the flue is installed such that any condensation is continuously drained. All flues should have a minimum slope of 3° upwards in the direction of the exhaust gas flow (no horizontal sections). All joints should be such that any condensation is directed back down the slope to an open drain connection in the flue. The drain pipe must be manufactured from a corrosion resistant material and be at least 15mm diameter. It must also have a fall of at least 2-3° (approx. 30-50mm per meter) and connect to a drain via a waste trap.
- Boiler flue outlet sizes - A flue system designed with the same diameter as the boiler flue outlet may not provide satisfactory performance in all applications. Conversely a flue system designed with a smaller diameter than the boiler flue outlet may provide satisfactory performance. Consideration must be given to the correct calculation of the required flue size. If in any doubt consult Hamworthy Heating Ltd who working in partnership with Midtherm Engineering Ltd can provide a comprehensive flue design and installation package.

C1.2 Waste Gas Volume and Temperature.

It is recommended that the volume and temperature of the waste gases used for design of the flue system are as given in the above tables.

C1.3 Materials.

Materials used for the flue system must be mechanically robust, resistant to internal and external corrosion, non-combustible and durable under the conditions to which they are likely to be subjected. Consideration must be given to avoid possible freezing of condense water traps and pipework

WARNING: THE FLUE SYSTEM MUST BE SELF SUPPORTING AND NOT PRESENT A RISK TO PEOPLE IN OR AROUND THE BUILDING.

C1.4 Suction

The maximum number of Modules firing into a common chimney is 9. (IM11/IGEUP10 states 8 for a natural draft flue). For larger installations refer to HHL Technical.

The flue system referred to in Table C1.1 must be designed acknowledging that there is a positive pressure generated by the boiler combustion fan. It is recommended that a draught stabiliser is fitted to the flue system where the suction is likely to be negative at the boiler connection. Any stabiliser fitted must be in or close to the vertical chimney.

The flue system must be designed to limit the **maximum suction (cold) to 30Pa negative**, measured at the connection to the boiler. Should the suction be greater than 30Pa, refer to HHL technical.

This condition must then be checked **Hot** and with all boilers firing, the maximum pressure condition at the connection to the boiler is **150Pa positive**.

In the event that the flue system when **Hot** does generate a suction, the **maximum suction is 100Pa**.

Fan Dilution - The design must provide for the use of balancing and trim dampers, and their location and operation must be such that the constraints detailed above can be met. Care must be taken to ensure that the fan performance is matched to deliver the appropriate dilution, whilst ensuring that excessive suction is not applied to the boilers. If in doubt, refer to HHL Technical.

C1.5 Disconnection

Provisions should be made for disconnection of the flue pipe for servicing. It is advisable that bends are fitted with removable covers for inspection and cleaning as appropriate.

C1.6 Flue Discharge

The flue system must ensure safe and efficient operation of the boiler to which it is attached, protect the combustion process from wind effects and disperse the products of combustion to the external air. The flue must terminate in a freely exposed position and be so situated as to prevent the products of combustion entering any opening in a building. Where the flue diameter is less than 204mm (8") diameter a terminal must be fitted. Where the flue is of a larger size, consideration should be given to the fitting of a flue discharge terminal or grille to stop ingress of birds etc.

C1.7 Surface Temperatures

Combustible materials in the vicinity of the boiler and flue shall not exceed 65°C during boiler operation. The flue shall not be closer than 50mm to any combustible material, except where it passes through such material with a non-combustible sleeve when the air gap may not be less than 25mm.

C1.8 Location

The flue system must not be placed or fitted where there is undue risk of accidental damage to the flue pipe or undue danger to persons in the vicinity. Check that the flue and chimney are clear from any obstruction. Wessex ModuMax boilers are suitable for installation in a balanced compartment in accordance with the requirements of BS 6644. Consult Hamworthy Heating Technical Department for help or assistance if in doubt.

C1.9. Condensate Discharge

Figure C1.1.1 Flue Resistance

Model	Flue Dia. (mm)	Max Flue Length (m)	Equivalent Length (m) 90°	Equivalent Length (m) 45°
97/97 116/116	100	15	1.5	1.2
147/147	150	43	2.4	1.8
196/196		28		
254/254		22		
97/194c	180	101	2.8	2.1
97/291c		41		
116/232c	180	85	2.9	2.2
116/348c		35		
147/294c	250	163	4.4	3.4
147/441c		69		
196/392c		94		
196/588c		36		
254/508c	250	110	4.6	3.5
254/762c		44		

Due to the high thermal efficiency of the boiler, condensation will occur within the boiler casing during firing from cold conditions. A drain with an integral trap is fitted to the rear of each module suitable for connection to a 32mm plastic waste pipe (not Hamworthy Heating Ltd supply), which must be connected to a tundish (not Hamworthy Heating Ltd supply). Discharge piping from a tundish should be of synthetic material due to the mild acidity of the condensate (pH3-5), with all discharge piping having a minimum fall of 30mm/m away from the boiler. Consideration should be given to possible freezing of condensate water traps and pipework. This must be avoided at all times by routing pipework within the building, where possible. In addition to the above the stacked module arrangement flue boxes are supplied with a trap terminating in a 32mm i.d. connection, which should be connected in a similar manner to a drain.

Connection of 100mm dia. Ducts — Open Flue Systems

Refer to Figure C1.1.2. Fit the flue components on route to the terminal discharge taking care not to damage the flue seal when assembling the flue components, and ensuring a minimum 2° slope and that the flue system is self supporting using wall brackets where necessary. In terminating the flue system, ensure that the joint through the wall / roof is made good and weatherproofed.

Important - In fitting the HHL supplied 100mm dia. Ducts to a stainless steel flue system, the flue system must have it's own condensate drain. The system must not be allowed to drain back through the HHL supplied components.

Figure C1.1.2 - Open Natural Draught (B23/B23p) Flue System - applies to 97 & 116 single boilers only
Figure C1.1.2 - Open Natural Draught (B23/B23p) Flue System (Multiple Boiler Installations)

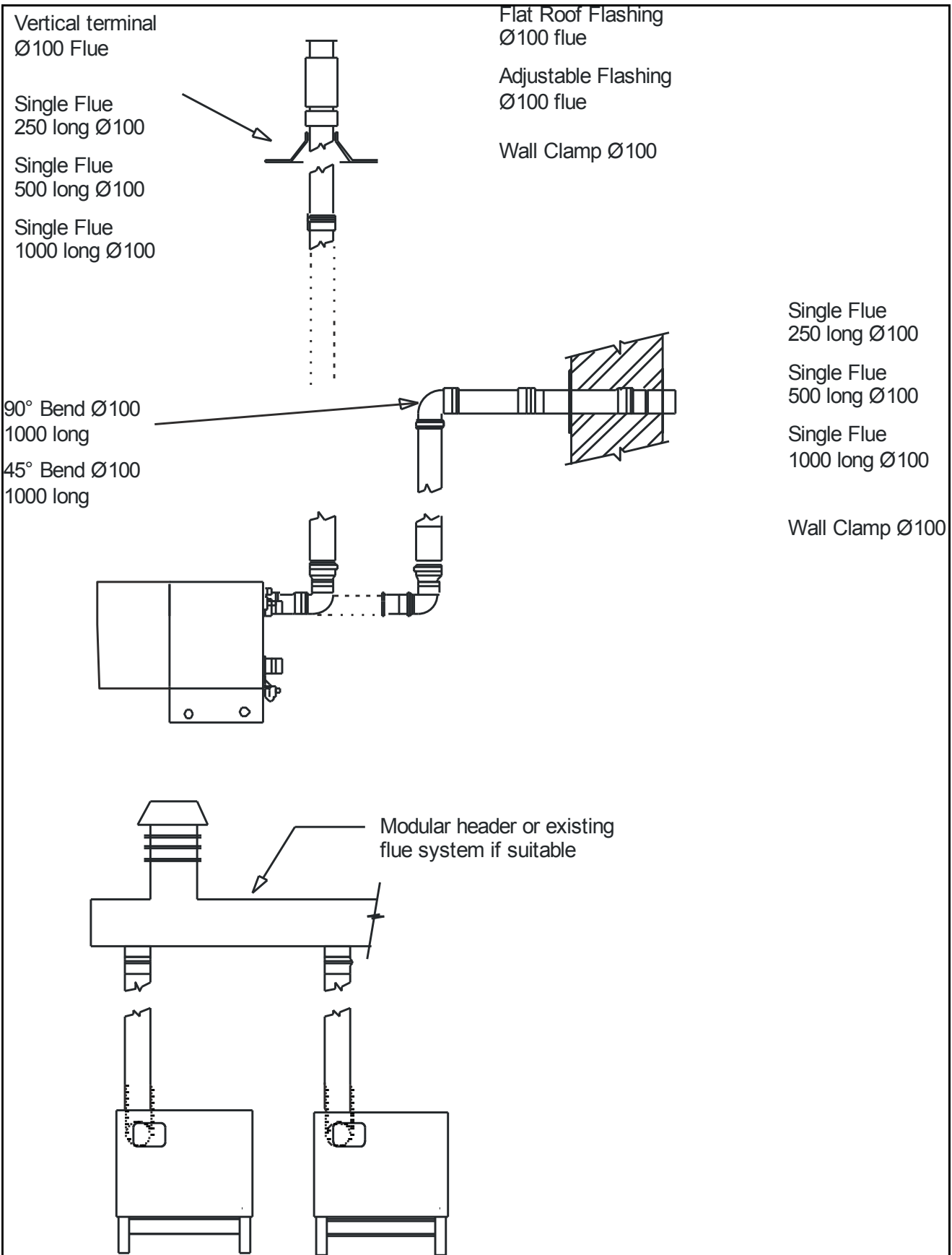

APPENDIX D - VENTILATION

D1.1 Air Supply

Detailed recommendations for air supply are given in BS 6644 and BS5440 Pt 2. The following notes are intended to give general guidance. In all cases there must be provision for an adequate supply of air for both combustion and general ventilation, in addition to that required for any other appliance.

Note: For Open flue applications, combustion air for the boiler is drawn through the top of the boiler casing. The air inlets **must** be kept open and free from blockage at all times.

LPG - installations. It is strongly recommended that gas detection equipment is fitted. This equipment should be positioned near the boiler(s) and at low level. The space housing the boiler(s) must be ventilated at high and low level in accordance with the following;

D1.2.1 Air Supply by Natural Ventilation - Open Flue applications

The boiler room must have, or be provided with, permanent air vents directly to the outside air, at high level and at low level. For an exposed boiler house, air vents should be fitted, preferably on all four sides, but at the least on two sides. Air vents should have negligible resistance and must not be sited in any position where they are likely to be easily blocked or flooded or in any position adjacent to an extraction system which is carrying flammable vapour. Grilles or louvres must be so designed that high velocity air streams do not occur within the space housing the boiler.

Boiler house ventilation

Low level (inlet) - 4cm² per kW of total rated input (Net)
High level (output) - 2cm² per kW of total rated input (Net)

Compartment ventilation

Where the boiler is to be installed in a cupboard or compartment, permanent high and low level ventilation is required which must communicate direct to outside, for cooling purposes.

Low level (inlet) - 10cm² per kW of total rated input (Net)
High level (output) - 5cm² per kW of total rated input (Net)

D1.2.2 Air Supply by Natural Ventilation - Room Sealed Installations

Where the boiler(s) are to be installed in a boiler room or internal space, the room or internal space must have permanent air vents directly to the outside air, at high level and at low level with the general requirements detailed above on location and construction.

Boiler house ventilation

Low level (inlet) - 2cm² per kW of total rated input (Net)
High level (output) - 2cm² per kW of total rated input (Net)

Compartment ventilation

Where the boiler is to be installed in a cupboard or compartment, permanent high and low level ventilation is required which may communicate to an adjoining room or outside, for cooling purposes.

Ventilation to a room or internal space - 10cm² per kW of total rated input (Net)
Ventilation direct to outside - 5cm² per kW of total rated input (Net)

D1.3 Air Supply by Mechanical Ventilation

Air supplied to the boiler room by Mechanical means should be as follows:

- 1) Mechanical ventilation must be interlocked with the boilers to prevent operation in the event of ventilation fan failure
- 2) Mechanical inlet and mechanical extract can be utilised providing the design extraction rate does not exceed one third of the design inlet rate.
- 3) Mechanical extract ventilation with natural inlet ventilation **MUST NOT** be used.

For Mechanical ventilation systems an automatic control should be provided to cut off the gas supply to the boiler, in the event of failure of air flow in either inlet or extract fans.

D 1.4. Boiler House Temperatures

The air supplied for boiler house ventilation shall be such that the maximum temperatures within the boiler house shall be as follows:

At floor level (or 100mm above floor level) = 25°C.

At mid-level (1.5m above floor level) = 32°C.

At ceiling level (or 100mm below ceiling level) = 40°C.

D 1.5. General Requirements

The air supply should be free from contamination such as building dust and insulation fibres from lagging. To avoid unnecessary cleaning and servicing of the boiler modules, the boilers should not be fired whilst building work is being undertaken.

High and low level ventilation grilles shall be positioned as high and as low as practicably possible. Low level grilles should be located within 1 metre of the floor for Natural Gas and within 250mm of the floor for LPG. High level grilles should be positioned within 15% of the boiler room height from the ceiling. High and low level grilles shall communicate with the same room or space where compartment ventilation is used. Where grilles communicate directly with outside air, they shall be positioned on the same wall.

Figure D1 Mechanical Ventilation Flow Rates

Boilers Without Draught Diverters	Flow rate per kW total rated heat input (net)	
	Inlet air (Combustion ventilation)	Difference between inlet and extract air (Inlet minus extract ventilation)
	m ³ /h	m ³ /h
	2.6	1.35 +/- 0.18

Note * : Where the associated air extraction is also by means of a fan, this shall be selected such as not to cause a negative pressure to develop in the boiler house and to maintain the difference between inlet and extract flow rates shown above.

The calculated extract flow rate is the actual inlet flow rate minus the appropriate figure in the table above.

APPENDIX E - WATER DATA

Table E1.1—Water Data

Model	97 /97	116/116	147/147	196/196	254/254
Water Connections (Flow & Return)	G 1½" male		G 2½" male		
Maximum Water Pressure - bar g - (kPa)	10 (1000)				
Water Content (litres) -excluding headers	16	16	22	22	22
System Design Flow Rate (litres/s) @ 11°C ΔT Rise	2.2	2.6	3.3	4.3	5.4
System Design Flow Rate (litres/s) @ 20°C ΔT Rise	1.2	1.4	1.8	2.4	3
System Design Flow Rate (litres/s) @ 30°C ΔT Rise	0.8	1.0	1.2	1.6	2.0
System Design Flow Rate (litres/s) @ 40°C ΔT Rise	0.6	0.7	0.9	1.2	1.5
Waterside Pressure Loss (mbar) @ 11°C ΔT Rise	61	91	500	850	1300
Waterside Pressure Loss (mbar) @ 20°C ΔT Rise	20	27	145	246	395
Waterside Pressure Loss (mbar) @ 30°C ΔT Rise	9	14	60	120	180
Waterside Pressure Loss (mbar) @ 40°C ΔT Rise	5	7	36	62	100
Minimum flow temperature setting	30°C @ 11°C ΔT 30°C @ 20°C ΔT 40°C @ 30°C ΔT 50°C @ 40°C ΔT				

E1.1 Water Circulation System

The Wessex ModuMax boiler has a low water content and the requirements of minimum water flow are given in the above table. Recommendations for the water circulation system are given in BS 6644 and CP 342.

The following details are of particular importance for the correct installation of the water circulation system:

- 1) In a combined central heating and hot water system the hot water storage vessel must be of the indirect cylinder or calorifier type. The hot water storage vessel should be insulated, preferably with not less than 75mm (3") thick mineral fibre, or its thermal equivalent.
- 2) Circulating pipework not forming part of the useful heating surface should be insulated to help prevent heat loss and possible freezing, particularly where pipes are run through roof spaces and ventilated cavities. Cisterns situated in areas which may be exposed to freezing conditions should also be insulated. Furthermore, insulation exposed to the weather should be rendered waterproof.
- 3) Drain valves must be located in accessible positions which permit the draining of the whole system, including the boiler and hot water storage vessel.
- 4) Each boiler module has G1½ or G2½ (refer to Table E1.1) male flow (indicated with a red spot) and return (indicated with a blue spot) connections. Boilers should be connected by flow and return headers. Headers should be connected to the system in a 'reverse / return' arrangement (the water flow in each header is in the same direction) to ensure equal flow in each module, or with a 'single pipe header system'. Figure E1.1.1 on the following page show typical layouts.
- 5) Ideally, individual valves should be fitted to each module to enable isolation from the system, however, the arrangement must comply with the requirements of BS 6644.

Figure E1.1.1 - Typical Piping Layouts

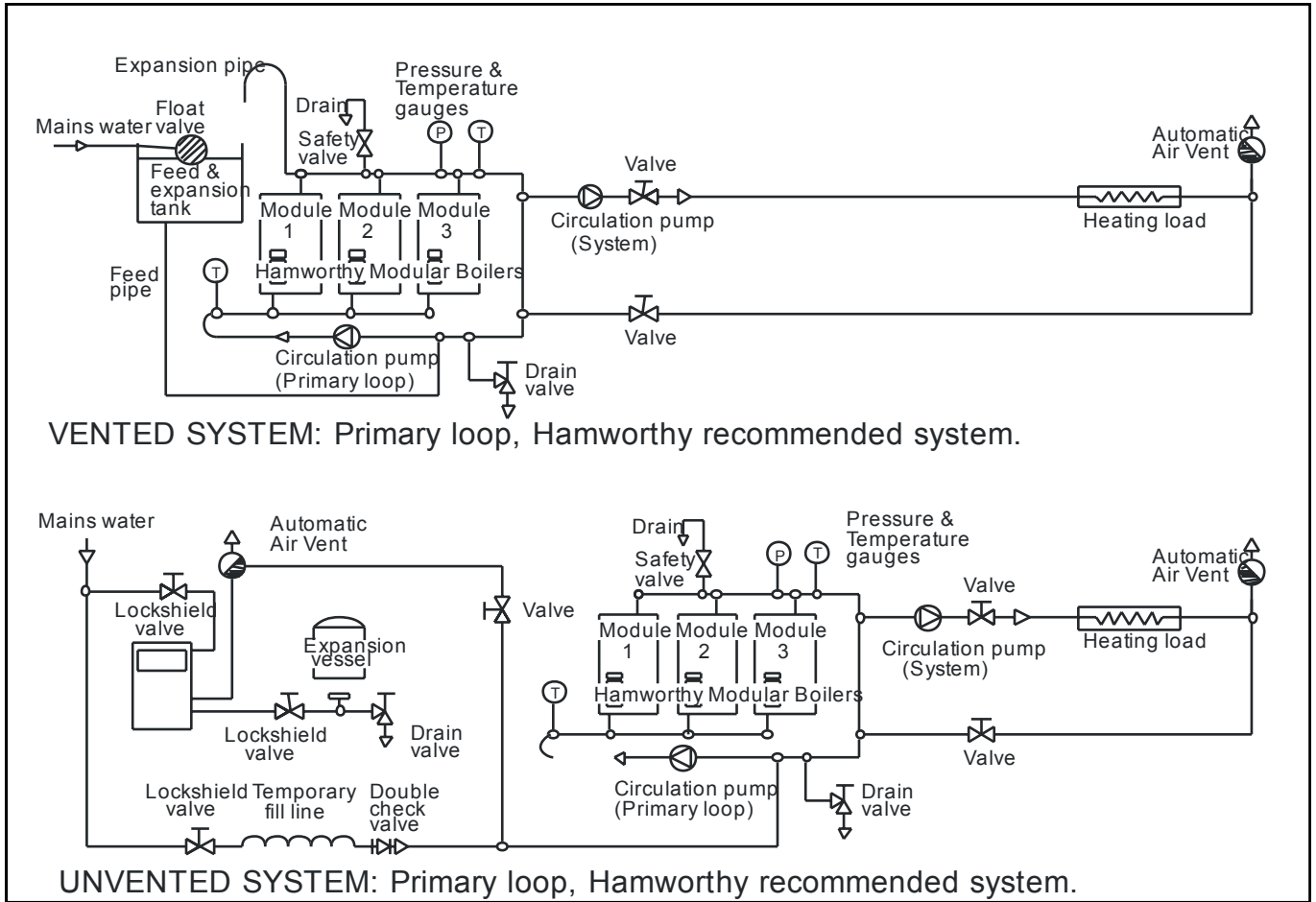

E1.2 Minimum System Water Pressure

To comply with guidance note **INDG436 (Health and Safety Executive)**, the minimum pressure requirements at the boiler are given below :-

Individual boiler @ 82°C	0.5 bar
Multiple boilers	
With flow isolation (pump or valve) @ 82°C	0.5 bar
Without flow isolation @ 11°C rise across the system @ 82°C	0.5 bar
Without flow isolation @ 20°C rise across the system @ 82°C	1.0 bar
Without flow isolation @ 30°C rise across the system @ 82°C	1.7 bar
Without flow isolation @ 40°C rise across the system @ 82°C	2.6 bar

Please note that the maximum flow temperature available from the controls is 85°C

E1.3 Pressure Relief Valve (Safety Valve)

The most important single safety device fitted to a boiler is its safety valve. Each boiler module is provided with a capped R³/₄" stub pipe for the fitting of a safety valve (not supplied). BS 6644 provides comprehensive information for the selection and location of safety valves and attention is drawn to the higher capacity requirements of safety valves for pressurised hot water systems.

Figure E1.3 Cold Feed and Vent Pipe Sizes

Boiler Output	Feed mm	Vent mm
60 - 150kW	25	32
150 - 300 kW	32	38
300 - 600 kW	38	50
>601 KW	50	65

E1.4 Open Vent and Cold Feed Pipe.

Every boiler or group of boilers should have an open vent pipe and cold feed pipe installed between the boiler and the first water isolating valve. The minimum bore (mm) of these pipes per installation is shown in the table. The vent pipe must rise continually, any valve fitted between a boiler and the open vent pipe for maintenance purposes shall be of the 3 way type such that when closed to the vent pipe the boiler will be open to atmosphere. The vent pipe shall be protected against freezing where this might occur. See BS 6644 for detailed information on Open Vent and Cold Feed Pipes.

E1.5 Altitude Gauge (Water Pressure Gauge)

Every boiler or group of boilers should be provided with an altitude gauge complete with isolating valve. See Figure E1.1.1 for typical position.

E1.6 Thermometer

A thermometer complete with pocket should be fitted in the pipework to indicate water flow temperature. See Figure E1.1.1 for typical position.

E1.7 Drain Valves

Each boiler should have a 15mm NB drain valve (not Hamworthy Heating Ltd supply) fitted in the boiler return to drain the boiler only. The heating system in total should have drain valves as recommended by BS 6644. See Figure E1.1.1 for typical position.

E1.8 Circulating Pump

One or more circulating pumps will be required to circulate water around the boilers and heating system. The pump should be sited to facilitate servicing. It is important that when Wessex ModuMax boilers are used to replace boilers on an existing system, the pumps should be checked for performance against the new boiler waterside pressure loss to ensure that the minimum flow rate can be obtained. It is also important that the existing system be flushed through twice to remove any loose matter which may have accumulated. If in any doubt regarding the cleanliness of the system, a coarse filter should be fitted in the return pipework to the boilers.

If boilers are run off time clock control a pump overrun (not Hamworthy Heating Ltd supply) should be fitted which must run for a minimum of 5 minutes on shutdown of the last boiler. This must be interlocked to the LMS for frost protection.

E1.9 Minimum Water Flow Rates

Minimum water flow rates are shown in table at beginning of Appendix E. These flow rates should be maintained through the boiler at all times whilst the boiler is firing. If the water flow rate is allowed to fall below the minimum the boiler heat exchanger could fail due to the resultant scale formation. Particular attention should be paid to the restriction of external flow circuits during periods of low heat demand.

E1.10 Waterside Pressure Drop

The waterside hydraulic resistance (Pressure drop) is given in table at beginning of Appendix E.

E1.11 Water Flow Controls

Any external mixing valve / shunt pump or similar controls MUST always ensure that the minimum water flow rate as given in table at beginning of Appendix E is maintained. If there is any doubt relating to site flow conditions it is suggested that a flow switch is fitted. The flow switch should be connected such that the boiler will shut down if insufficient flow occurs.

E1.12 Frost Protection

Consideration should be given to fitting a frost thermostat set at approximately 4°C.

E1.13 Unvented Systems

Refer to Figure E1.1.1 on opposite page for typical layout of an unvented (Pressurised) Hot Water System. For system design refer to BS 7074 Part 2. In order to correctly size a pressurisation unit for any heating system the following parameters are required.

- 1) Static height of highest component in system (metres)
- 2) System volume. If this is not known, a general rule of thumb of 10litres/kW of installed boiler power can be used.
- 3) Maximum flow temperature (°C)
- 4) Maximum system hot working pressure, generally given in bar gauge.

From the parameters given, Hamworthy Heating can size the pressurisation unit and also the expansion vessel required.

Care must be taken in sizing expansion vessels to ensure maximum acceptance factors are not exceeded. Normally manufacturers of vessels impose a limit of 0.5. This value must not be exceeded at any time during the operation of the boiler, this includes the over pressure condition should a safety valve lift.

Consideration should also be given to sizing of the safety valve(s) in the system. Refer to BS 6759: Part 1 for further information and to BS 6880: Part 1 for design considerations.

Hydraulic Schemes: For Single Boiler Installations

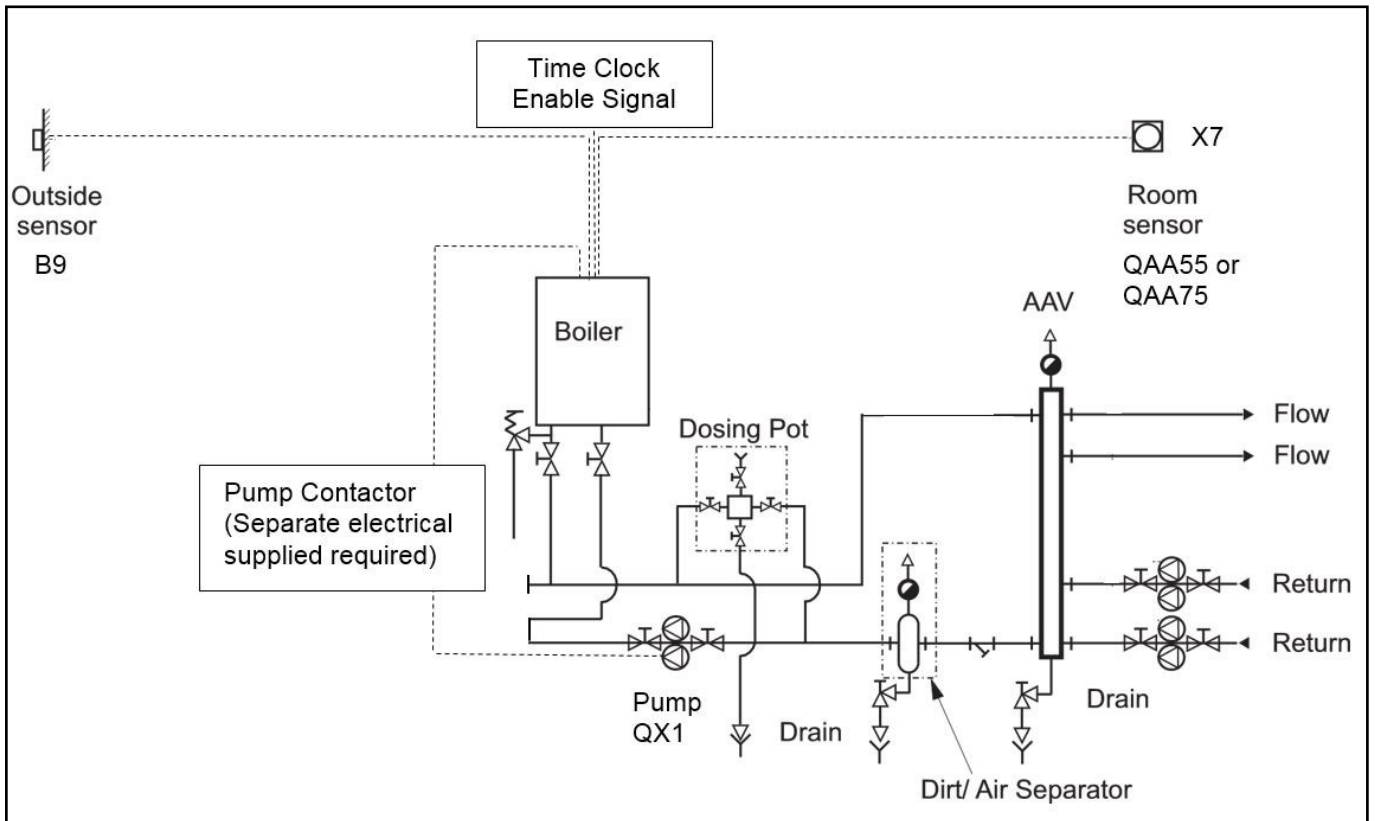

Figure E 1.3.1 - Schematic 1 - External Time Clock Enabled Boiler

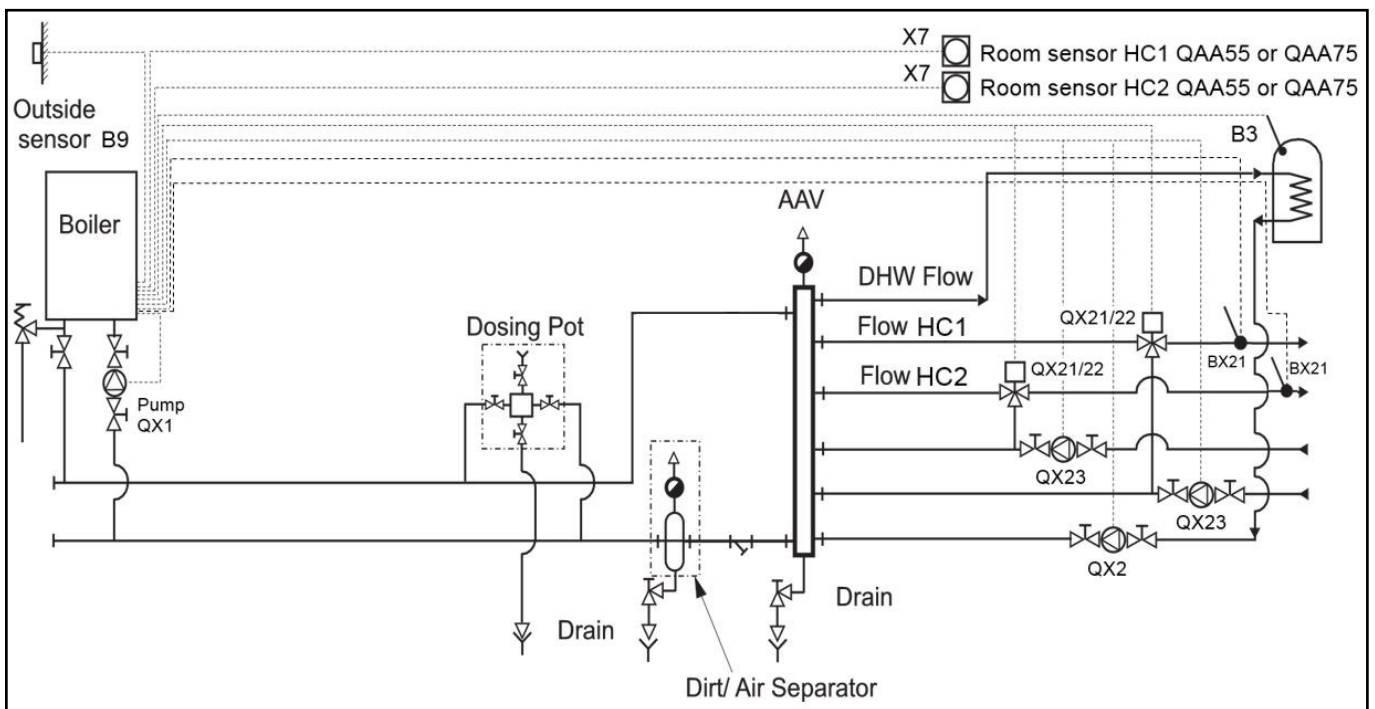

Figure E 1.3.2 - Schematic 2 - Two Heating Circuits with DHW & Boiler Shunt Pump

Hydraulic Schemes: For Multiple Boiler Installations

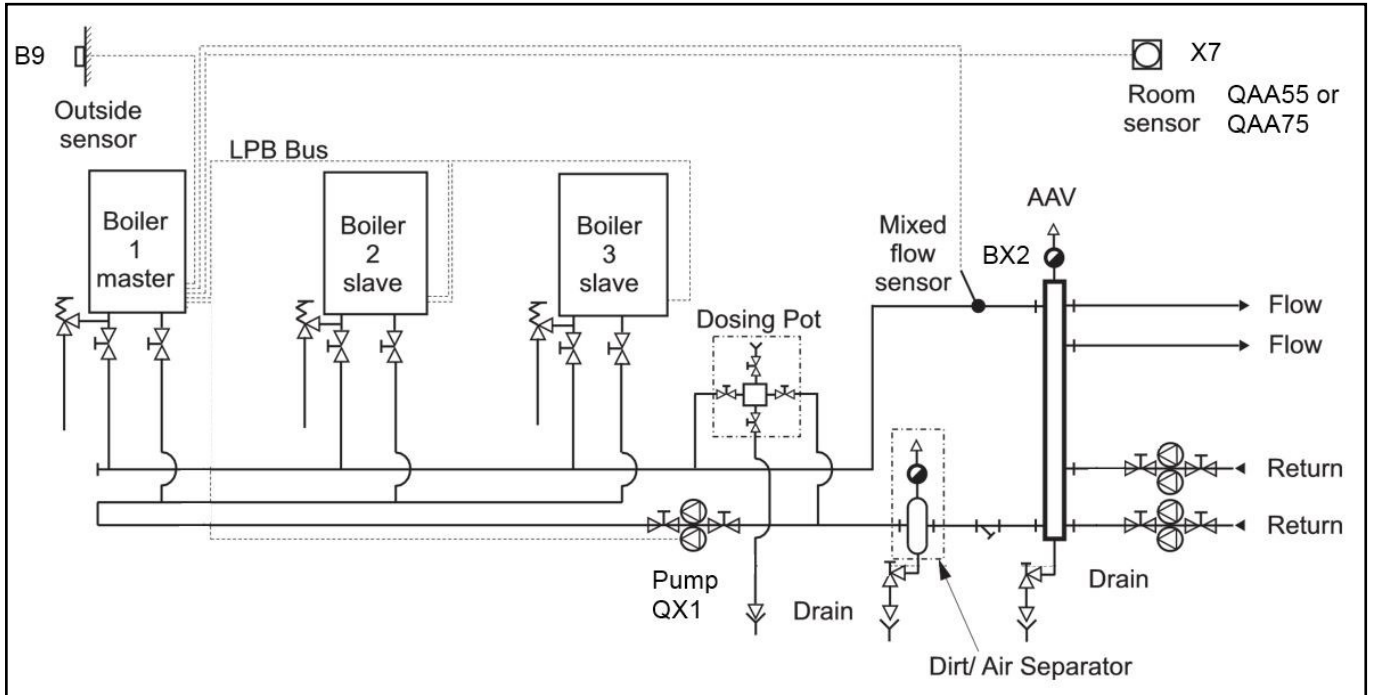

Figure E 1.3.3 - Schematic 3 - Master and Slave Sequence Control With Reverse Return Primary

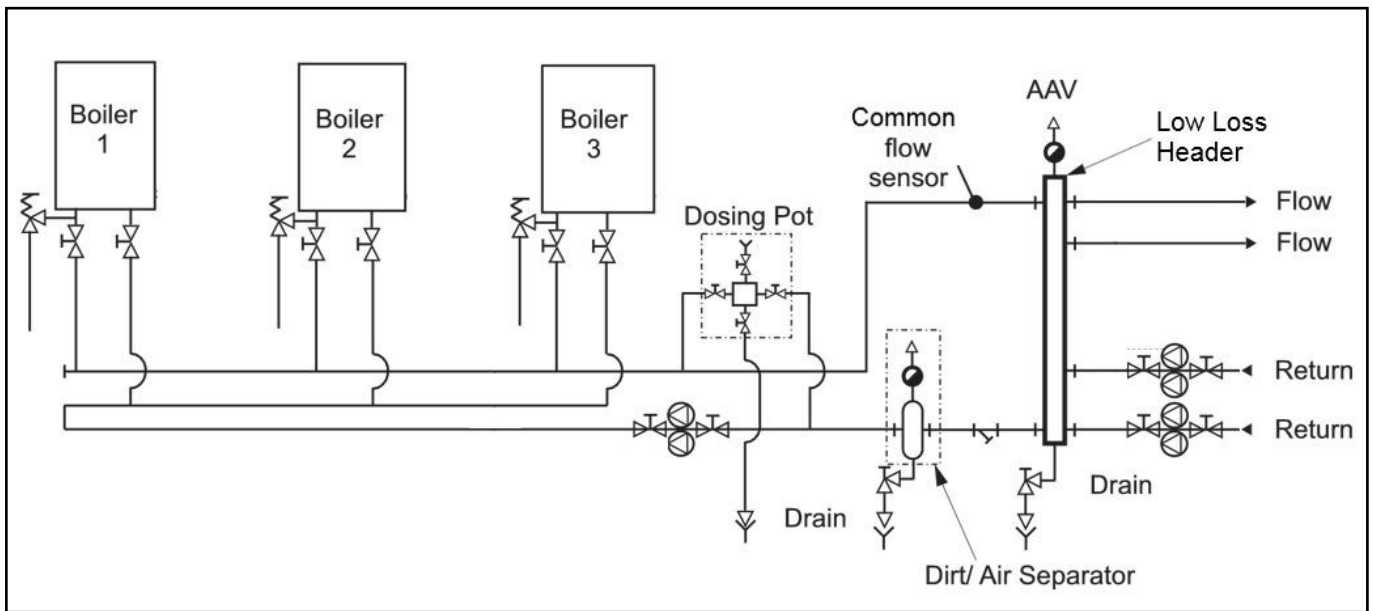

Figure E 1.3.4 - Schematic 4 - Reverse Return Primary Circuit

Hydraulic Schemes:

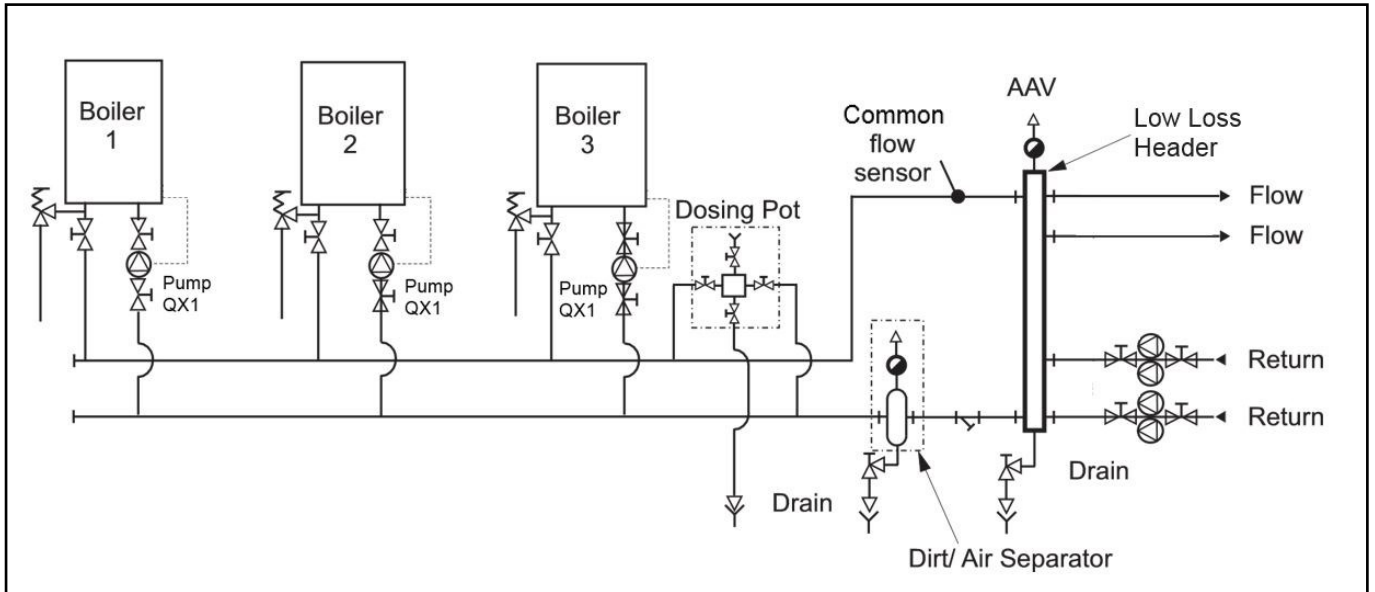

Figure E 1.3.5 - Schematic 5 - Primary Circuit With Individual Boiler Shunt Pumps

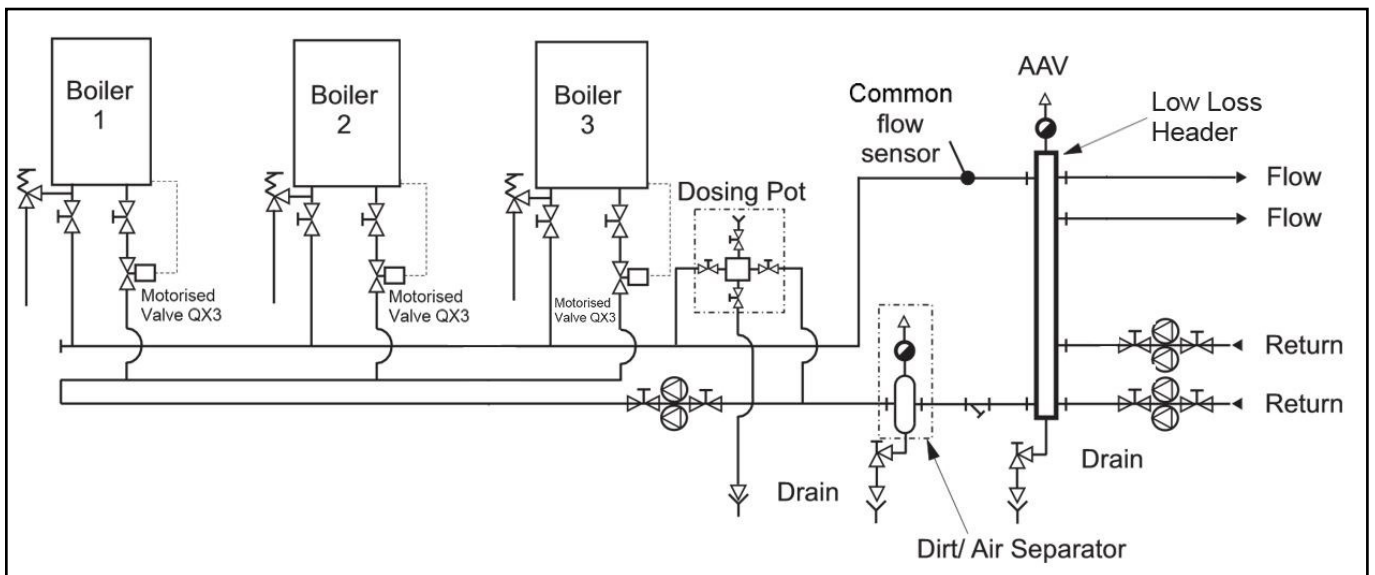

Figure E 1.3.6 - Schematic 6 - Reverse Return Primary Circuit with Individual Motorised Boiler Isolation

Note:

Motorised valves can be either power open/power close or power open/spring return close.

Hydraulic Schemes:

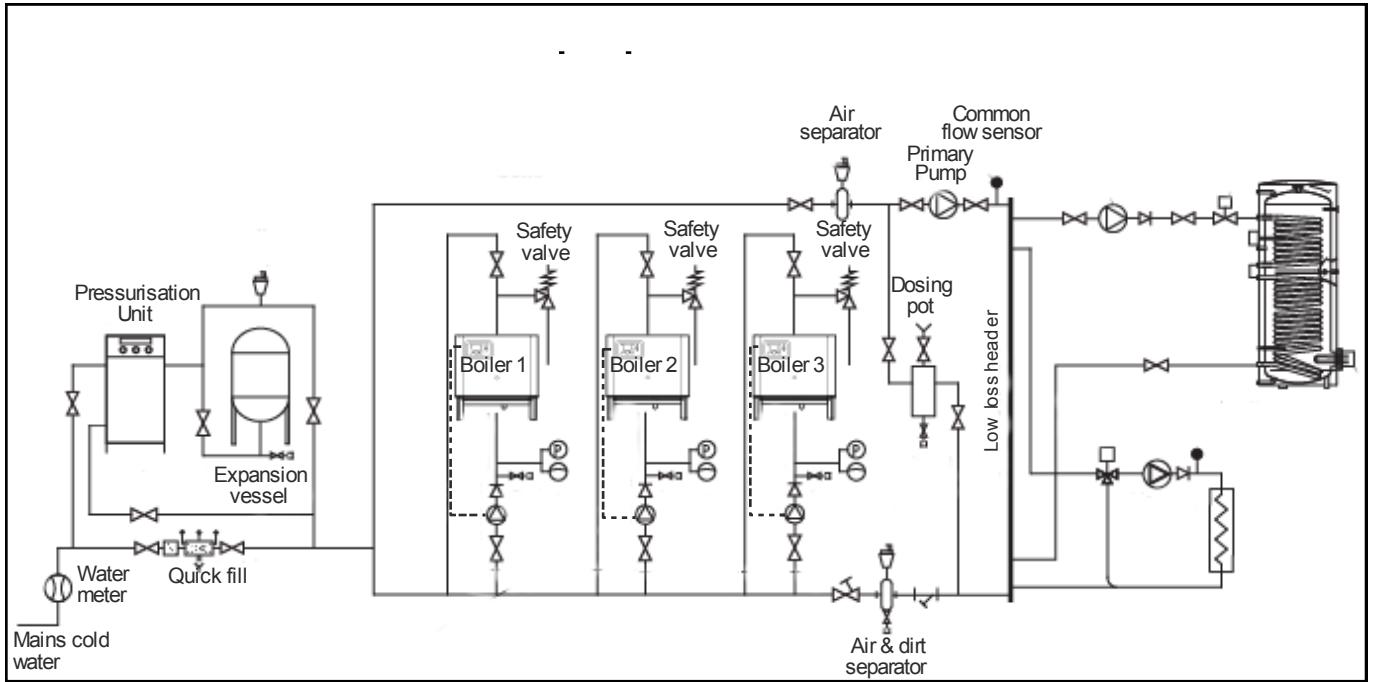

Figure E 1.3.7 - Schematic 7 - Single Pipe Primary Circuit

Boiler Parameter Settings: Single Boiler

Enable with external time clock for constant temperature

Legend E = End user I = Commissioning F = Heating engineer

<u>Menu</u>	<u>Operating Line</u>	<u>User Level</u>	<u>Function</u>	<u>Setting</u>
LPB System	6600	F	Device address	1
	6630	F	Cascade Master	Automatically
Configuration	5710	F	Heating circuit 1	Off
	5977	F	Function of input H5	Consumer circuit VK1
Consumer Circuit 1	1859	F	Flow temperature setpoint	80°C or as required

Note:

Use H5 wiring connection to enable boiler requires volt free enable from time clock.

Optional extras required for this configuration:

None

External time clock with weather compensation

Legend E = End user I = Commissioning F = Heating engineer

<u>Menu</u>	<u>Operating Line</u>	<u>User Level</u>	<u>Function</u>	<u>Setting</u>
LPB System	6600	F	Device address	1
	6630	F	Cascade Master	Automatically
Heating Circuit 1	900	F	Operating mode Changeover	Automatic
Configuration	5710	F	Heating circuit 1	On
	5977	F	Function of input H5	HCS
	5978	F	Contact type H5	NC
Heating Circuit 1	740	F	Flow temp min set point	50
	741	F	Flow temp max set point	80
	720	F	Heating curve slope	3
	726	F	Heating curve slope adaption	On
Operation section	26	F	Operation lock	On
Hot water mode	No display			

Note:

Use H5 wiring connection to enable boiler requires volt free enable from time clock.

Optional extras required for this configuration:

External air sensor	– QAC34	Part number 533901457
Room sensor choice	– QAA55—Offset adjustable room sensor	Part number 533901589
	– QAA75—Programmable room sensor	Part number 533901587

Boiler Parameter Settings: Multiple Boilers

Sequence control using integral Master and Slave configuration

Single primary pump set for fixed flow rate operation (pump will have to be low energy type)

The table below shows all available settings up to the heating engineer level. However, certain operating lines may be hidden, for security purpose

Legend E = End user I = Commissioning F = Heating engineer

<u>Menu</u>	<u>Operating Line</u>	<u>User Level</u>	<u>Function</u>	<u>Setting</u>
LPB System	6600	F	Device address	Boiler 1 set to 1 (master) Boiler 2 set to 2 Additional boilers set to 3, 4 ect.
	6601	F	Segment address	Boilers all set to 0
	6640	F	Clock mode	Boilers 1 set to Master
	6630	F	Cascade	Boilers additional set to Slave with remote setting Boiler 1 set to always Boilers additional set to Autonomously
Configuration	5710	F	Heating Circuit 1	Boiler 1 set to on Boilers additional set to off
	5890	F	Relay output QX1	Boiler 1 set to Cascade pump Q25
	5931	F	Sensor input BX2	Boiler 1 Master Common flow sensor B10 Boilers additional set to none
	6117	F	Central compensation set up	Boilers all set to 5
	6200	F	Save sensors	Boilers all set to yes

Internal time clock settings

Settings must be programmed to master boiler

<u>Menu</u>	<u>Operating Line</u>	<u>User Level</u>	<u>Function</u>	<u>Setting</u>
Time program	500	E	Mon-sun: Mon-Fri:	As req
Heating Circuit 1	501	E	1st period on	
	502	E	1st period off	
	503	E	2nd period on	
	504	E	2nd period off	
	505	E	3rd period on	
	506	E	3rd period off	
Configuration	5710	F	Heating circuit 1	On

External enable—e.g. Remote time clock

Settings must be programmed to master boiler

<u>Menu</u>	<u>Operating Line</u>	<u>User Level</u>	<u>Function</u>	<u>Setting</u>
Configuration	5710	F	Heating circuit 1 1—on/off	On
	5950	F	Function of remote Input H1	Operating mode changeover HC1
	5951	F	Define time clock Switch—no/nc contacts	As required
Heating mode	Auto symbol			
Hot water mode	Off			

Optional extras required for this configuration:

Heating sensor kit – QA236

LPB bus communication module OC1345—one per boiler module

Part number 563605674

Part number 563605667

Boiler Parameter Settings: Multiple Boilers

Individual boilers enabled from B.M.S. using 0-10V analogue input

Legend E = End user I = Commissioning F = Heating engineer

Navistem settings

BMS 0-10v Power Control

<u>Menu</u>	<u>Operating Line</u>	<u>User Level</u>	<u>Function</u>	<u>Setting</u>
LPB System	6600	F	Device address	1
Configuration	5710	F	Heating circuit 1	Off
	5950	F	Function input H1	Output req VK1 10v
	5951	F	Contact type H1	NO
	5953	F	Voltage value H1	0.1v
	5954	F	Function value 1 H1	200 (200 = 20% modulation)
	5955	F	Voltage value 2 H1	10.0v
	5956	F	Function valve 2 H1	1000 (1000 = 100% modulation)
	5890	F	Relay output QX1	Boiler pump Q1

BMS 0-10v Temperature

<u>Menu</u>	<u>Operating Line</u>	<u>User Level</u>	<u>Function</u>	<u>Setting</u>
LPB System	6600	F	Device address	1
Configuration	5710	F	Heating circuit 1	Off
	5950	F	Function input H1	Consumer req VK1 10v
	5951	F	Contact type H1	NO
	5953	F	Voltage value H1	0.5v
	5954	F	Function value 1 H1	0 (0 = 0°C)
	5955	F	Voltage value 2 H1	10.0v
	5956	F	Function valve 2 H1	800 (800 = 80°C)
	5890	F	Relay output QX1	Boiler pump Q1

Note:

Use H1 wiring connection for 0-10V analog input from B.M.S.

Optional extras required for this configuration:

None

Boiler Parameter Settings: Individual Boiler Shunt Pumps

Legend E = End user I = Commissioning F = Heating engineer

<u>Menu</u>	<u>Operating Line</u>	<u>User Level</u>	<u>Function</u>	<u>Setting</u>
Configuration	5890	F	Relay output QX1	Boiler pump Q1

Optional extras required for this configuration:
None

Boiler Parameter Settings: Individual Boiler Flow Isolation Using Motorised Valve

Legend E = End user I = Commissioning F = Heating engineer

<u>Menu</u>	<u>Operating Line</u>	<u>User Level</u>	<u>Function</u>	<u>Setting</u>
Configuration	5892	F	Relay output QX3	Boiler pump Q1

Note:
The QX3 terminals have live outputs on NO & NC connection together with neutral & earth this will facilitate powering the valve open and closed.

Optional extras required for this configuration:
None

Boiler Parameter Settings: Multiple Boilers With External Merley Boiler Sequence Controller

The maximum number of boiler modules that can be controlled from Merley boiler sequence controller is 16.

The table below shows all available settings up to the heating engineer level. However, certain operating lines may be hidden, for security purposes

Legend E = End user I = Commissioning F = Heating engineer

<u>Menu</u>	<u>Operating Line</u>	<u>User Level</u>	<u>Function</u>	<u>Setting</u>
LPB System	6600	F	Device address	Boiler 1 set to 2 Boiler 2 set to 3 Additional boilers set to 4, 5 ect.
	6601	F	Segment address	Boilers all set to 0
	6640	F	Clock mode	Boilers all set to Slave with remote setting
Configuration	5710	F	Heating Circuit 1	Boilers all set to off
	6200	F	Save sensors	Boilers all yes
	6117	F	Central compensation set up	Boilers all set to 5

Note:
Merley to be set up independently using the Merley O&M (500001210)

Optional extras required for this configuration:
 Merley wall mounted boiler sequence controller Part number 563605672
 Merley loose boiler sequence controller for panel mounting Part number 563605671
 LPB bus communication module OC1345—one per boiler module Part number 563605667

Note:
2x LPB bus communications modules are supplied with each Merley boiler sequence controller, therefore additional modules are only required for boiler module 3 upwards.

USEFUL USER INFORMATION

INSTALLER	SITE ADDRESS

BOILER TYPE	BOILER SIZE(S)	UNIT NO(S).	SERIAL NO(S).	FLUE

Notes

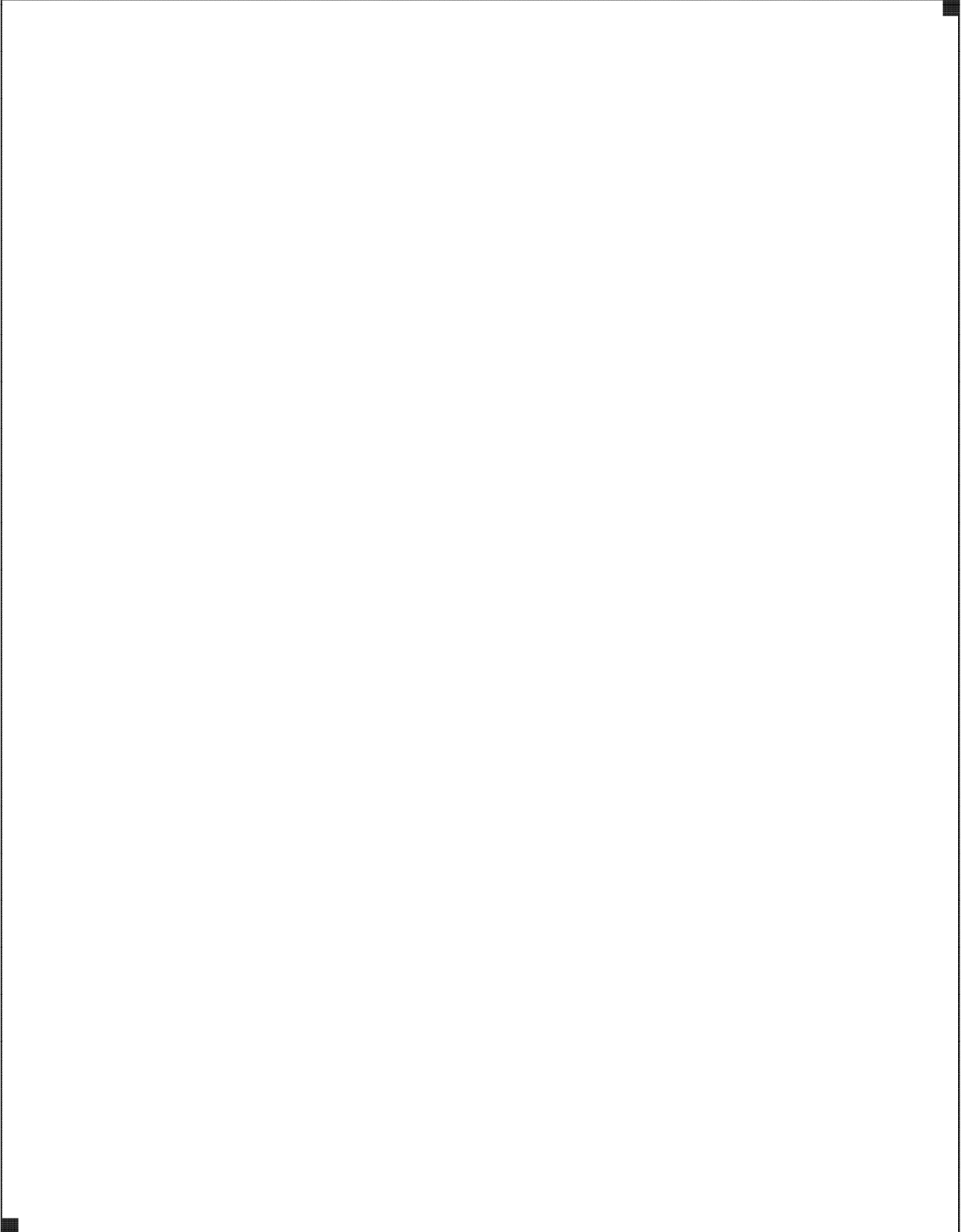

Hamworthy Heating Accredited Agents

Southern Ireland (Sales & Service)

HEVAC Limited
Naas Road, Dublin 12, Ireland
tel: **00 353 141 91919** fax: **00 353 145 84806**
email: **info@hevac.ie**

Scotland (Sales & Service)

McDowall Modular Services
2 Penson Road, Queenslie Industrial Estate, Glasgow, G33 4AG
tel: **0141 336 8795** fax: **0141 336 8954**
email:
MMS.McDowallModularServices@hamworthy-heating.com

Northern Ireland (Sales & Service)

HVAC Supplies Limited
Unit A6, Dargan Court, Dargan Crescent, Belfast BT3 9JP
tel: **028 9077 7737**
email: **hvacsupplies@btconnect.com**

North East England (Service)

Allison Heating Products
12 Sunnyside Lane, Cleadon Village, Sunderland SR6 7XB
tel: **0191 536 8833** fax: **0191 536 9933**
email: **allison.heating@gmail.com**

Hamworthy Heating Customer Service Centre

Sales

tel: **01202 662552**
email: **sales@hamworthy-heating.com**

Technical Enquiries

tel: **01202 662505**
email: **technical@hamworthy-heating.com**

Servicing

tel: **01202 662555**
email: **service@hamworthy-heating.com**

Spares

tel: **01202 662525**
email: **spares@hamworthy-heating.com**

British engineering excellence from Hamworthy Heating;
the commercial heating and hot water specialists.



Customer Service Centre

Hamworthy Heating Limited,
Wessex House,
New Fields Business Park,
Stinsford Road,
Poole,
Dorset,
BH17 0NF

Telephone: **01202 662500**
Fax: **01202 662522**
Email: **service@hamworthy-heating.com**
Website: **www.hamworthy-heating.com**