

MAXIMUS USERS

Instruction and **IE** recommendation booklet



VICTRIX EXA
28 1 ERP
32 1 ERP



Dear Customer,

Our compliments for having chosen a top-quality Immergas product, able to assure well-being and safety for a long period of time. As an Immergas customer you can also count on a qualified after-sales service, prepared and updated to guarantee constant efficiency of your boiler. Read the following pages carefully: you will be able to draw useful suggestions regarding the correct use of the appliance, the respect of which, will confirm your satisfaction for the Immergas product. For assistance and scheduled maintenance contact Authorised After-Sales centres: they have original spare parts and are specifically trained directly by the manufacturer.

General recommendations

All Immergas products are protected with suitable transport packaging.

The material must be stored in dry environments protected against bad weather.

The instruction book is an integral and essential part of the product and must be consigned to the new user also in the case of transfer or succession of ownership.

It must be stored with care and consulted carefully, as all of the warnings provide important safety indications for installation, use and maintenance stages.

This instructions manual provides technical information for installing Immergas boilers. As for the other issues related to boiler installation (e.g. safety in the work site, environment protection, injury prevention), it is necessary to comply with the provisions specified in the regulations in force and principles of good practice.

In compliance with legislation in force, the systems must be designed by qualified professionals, within the dimensional limits established by the Law. Installation and maintenance must be performed in compliance with the regulations in force, according to the manufacturer's instructions and by an authorised company, which has specific technical expertise in the system sector, as required by Law.

Improper installation or assembly of the Immergas appliance and/or components, accessories, kit and devices can cause unexpected problems to people, animals and objects. Read the instructions provided with the product carefully to ensure a proper installation.

Maintenance must be carried out by an authorised company. The Authorised After-sales Service represents a guarantee of qualification and professionalism.

The appliance must only be destined for the use for which it has been expressly declared. Any other use will be considered improper and therefore potentially dangerous.

If errors occur during installation, operation and maintenance, due to non compliance with technical laws in force, standards or instructions contained in this book (or however supplied by the manufacturer), the manufacturer is excluded from any contractual and extra-contractual liability for any damages and the appliance warranty is invalidated.

The company **IMMERGAS S.p.A.**, with registered office in via Cisa Ligure 95 42041 Brescello (RE), declares that the design, manufacturing and after-sales assistance processes comply with the requirements of standard **UNI EN ISO 9001:2008**.

For further details on the product CE marking, request a copy of the Declaration of Conformity from the manufacturer, specifying the appliance model and the language of the country.

Immergas S.p.A. declines all liability due to printing or transcription errors, reserving the right to make any modifications to its technical and commercial documents without prior notice.

INDEX

INSTALLER		USER		MAINTENANCE TECHNICIAN	
	page		page		page
1	Boiler installation	2	Use and maintenance instructions	3	Boiler commissioning
1.1	Installation recommendations	2.1	Cleaning and maintenance	(initial check)	26
1.2	Main dimensions	2.2	General warnings	3.1	Plumbing diagram
1.3	Antifreeze protection	2.3	Control panel	3.2	Wiring diagram
1.4	Gas connection	2.4	Using the boiler	3.3	Troubleshooting
1.5	Hydraulic connection	2.5	Troubleshooting	3.4	Converting the boiler
1.6	Electrical connection	2.6	Information menu	to other types of gas	28
1.7	Remote controls and room chrono- thermostats (Optional)	2.7	Boiler shutdown	3.5	Calibration of number of fan revs.
1.8	External probe (Optional)	2.8	Restoring central heating system pressure	3.6	Adjustment of the air-gas ratio
1.9	Immergas flue systems	2.9	System draining	3.7	Checks following conversion
1.10	Tables of resistance factors and equivalent lengths	2.10	Anti-freeze protection	to another type of gas	29
1.11	Outdoor installation in a partially protected area	2.11	Case cleaning	3.8	Programming the P.C.B.
1.12	Internal installation using a recessed frame with direct air intake	2.12	Decommissioning	3.9	Solar panels coupling function
1.13	Concentric horizontal kit installation			3.10	"Chimney sweep" function
1.14	Concentric vertical kit installation			3.11	Pump anti-block function
1.15	Separator kit installation			3.12	Three-way anti-block function
1.16	Adaptor C9 kit installation			3.13	Radiators antifreeze function
1.17	Ducting of flues or technical slots			3.14	P.C.B. periodical self-check
1.18	Configuration type B, open chamber and forced draught for indoors			3.15	Automatic vent function
1.19	Flue exhaust to flue/chimney			3.16	appliance check and maintenance
1.20	Flues, chimneys, chimney pots and terminals			3.17	Casing removal
1.21	System filling			3.18	Variable heat output
1.22	Condensate trap filling			3.19	Combustion parameters
1.23	Gas system start-up			3.20	Technical data
1.24	Boiler start up (ignition)			3.21	Key for data nameplate
1.25	Circulation pump			3.22	Technical parameters for combination boilers (in compliance with Regulation 813/2013)
1.26	Kits available on request			3.23	Product fiche (in compliance with Regulation 811/2013)
1.27	Boiler components			3.24	Parameters for filling in the package fiche

1 BOILER INSTALLATION

1.1 INSTALLATION RECOMMENDATIONS.

The VICTRIX EXA 28 1 ErP - 32 1 ErP boiler is designed for wall mounted installation only; for central heating and production of domestic hot water for domestic use and similar purposes. The place of installation of the appliance and relative Immergas accessories must have suitable features (technical and structural) such to allow (always in safety, efficiency and comfortable conditions):

- installation (according to the provisions of the technical legislation and technical regulations);
- maintenance operations (including scheduled, periodic, routine and special maintenance);
- removal (to outdoors in the place for loading and transporting the appliances and components) as well as their eventual replacement with appliances and/or equivalent components.

The wall surface must be smooth, without any protrusions or recesses enabling access to the rear part. They are NOT designed to be installed on plinths or floors (1-1).

By varying the type of installation the classification of the boiler also varies, precisely:

- **Type B₂₃ or B₅₃** boiler if installed using the relevant terminal for air intake directly from the room in which the boiler has been installed.
- **Type C boiler** if installed using concentric pipes or other types of pipes envisioned for the sealed chamber boiler for intake of air and expulsion of flue gases.

Note: appliance classification is provided in the depictions of the various installation solutions shown on the following pages.

Only professionally enabled companies are authorised to install Immergas gas appliances. Installation must be carried out according to regulation standards, current legislation and in compliance with local technical regulations and the required technical procedures.

Attention: Immergas declines all liability for damages caused by boilers removed from other systems or for any non-conformities of such equipment.

Before installing the appliance, ensure that it is delivered in perfect condition; if in doubt, contact the supplier immediately. Packing materials (staples, nails, plastic bags, polystyrene foam, etc.) constitute a hazard and must be kept out of the reach of children. If the appliance is installed inside or between cabinets, ensure sufficient space for normal servicing; therefore it is advisable to leave clearance of at least 3 cm between the boiler casing and the vertical sides of the cabinet. Leave adequate space above the boiler for possible water and flue removal connections. Keep all flammable objects away from the appliance (paper, rags, plastic, polystyrene, etc.).

Do not place household appliances underneath the boiler as they could be damaged if the safety valve intervenes with an obstructed conveying system (the safety valve must be conveyed away by a draining funnel), or if there are leaks from the hydraulic connections; on the contrary, the manufacturer cannot be held responsible for any damage caused to the household appliances. For the aforementioned reasons, we recommend not placing furnishings, furniture, etc. under the boiler.

In the event of malfunctions, faults or incorrect operation, turn the appliance off and contact an authorised company (e.g. the Authorised Technical Assistance centre, which has specifically trained staff and original spare parts). Do not attempt to modify or repair the appliance alone. Failure to comply with the above implies personal responsibility and invalidates the warranty.

• Installation regulations:

- this boiler can be installed outdoors in a partially protected area. A partially protected area is one in which the appliance is not exposed to the direct action of the weather (rain, snow, hail, etc.).

This type of installation is only possible when permitted by the laws in force in the appliance's country of destination.

- Installation of gas appliances, flue exhaust pipes and combustion air intake pipes is forbidden in places with a fire risk (for example: garages, closed parking stalls), and in potentially dangerous places.
- Installation is prohibited on the vertical projection of cooking hobs.
- Installation is forbidden in places/rooms that constitute public areas of apartment buildings, internal stairways or other escape routes (e.g. floor landings, entrance halls, etc.).
- Installation is also forbidden in places/rooms that constitute public areas of apartment buildings such as cellars, entrance halls, attics, lofts, etc., unless otherwise provided for by local regulations in force.

Attention: wall mounting of the boiler must guarantee stable and efficient support for the generator.

The plugs (standard supply) are to be used only in conjunction with the mounting brackets or fixing template to fix the appliance to the wall; they only ensure adequate support if inserted correctly (according to technical standards) in walls made of solid or semi-hollow brick or block. In the case of walls made from hollow brick or block, partitions with limited static properties, or in any case walls other than those indicated, a static test must be carried out to ensure adequate support.

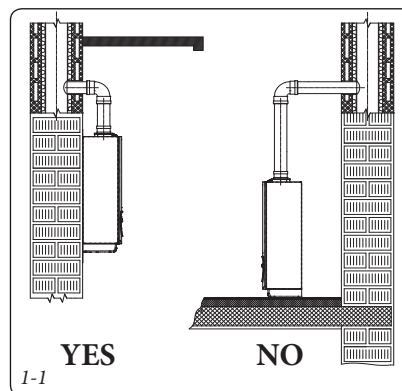

N.B.: the hex head screws supplied in the blister pack are to be used exclusively to fix the relative mounting bracket to the wall.

These boilers are used to heat water to below boiling temperature in atmospheric pressure. They must be connected to a central heating system and hot water circuit suited to their performance and capacity.

INSTALLER

USER

MAINTENANCE TECHNICIAN

1.2 MAIN DIMENSIONS.

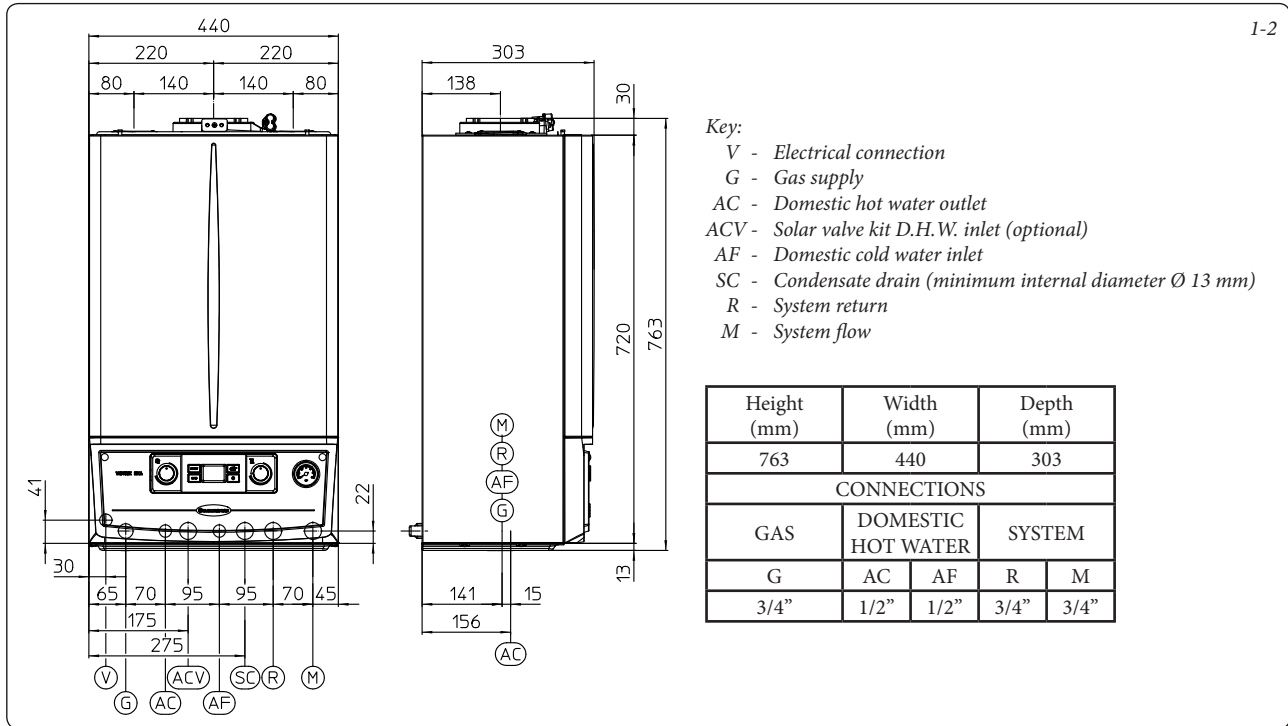

- Key:**
 V - Electrical connection
 G - Gas supply
 AC - Domestic hot water outlet
 ACV - Solar valve kit D.H.W. inlet (optional)
 AF - Domestic cold water inlet
 SC - Condensate drain (minimum internal diameter Ø 13 mm)
 R - System return
 M - System flow

Height (mm)	Width (mm)	Depth (mm)		
763	440	303		
CONNECTIONS				
GAS	DOMESTIC HOT WATER		SYSTEM	
G	AC	AF	R	M
3/4"	1/2"	1/2"	3/4"	3/4"

1.3 ANTIFREEZE PROTECTION.

Minimum temperature -5°C. The boiler comes standard with an anti-freeze function that activates the pump and burner when the system water temperature in the boiler falls below 4°C. In these conditions the boiler is protected against freezing to an ambient temperature of -5°C.

Minimum temperature -15°C. In the event the boiler is installed in a place where the temperature falls below -5°C, the appliance can freeze. To prevent the risk of freezing follow the instructions below:

- protect the central heating circuit from freezing by inserting a good-quality antifreeze liquid into this circuit, which is specially suited for central heating systems and which is manufacturer guaranteed not to cause damage to the heat exchanger or other components of the boiler. The antifreeze liquid must not be harmful to one's health. The instructions of the manufacturer of this liquid must be followed scrupulously regarding the percentage necessary with respect to the minimum temperature at which the system must be kept. An aqueous solution must be made with potential pollution class of water 2 (EN 1717:2002 or local regulations in force).

The materials used for the central heating circuit of Immergas boilers withstand ethylene and propylene glycol based antifreeze liquids (if the mixtures are prepared perfectly).

For life and possible disposal, follow the supplier's instructions.

- Protect the domestic hot water circuit against freezing by using an accessory that is supplied on request (anti-freeze kit) comprising two electric heating elements, the relevant cables and a control thermostat (carefully read the installation instructions contained in the accessory kit pack).

In these conditions the boiler is protected against freezing to temperature of -15°C.

Boiler antifreeze protection (both -5°C and -15°C) is thus ensured only if:

- the boiler is correctly connected to gas and electricity power supply circuits;
- the boiler is powered constantly;
- the boiler is not in "off" mode;
- the boiler is not in anomaly conditions (parag. 2.6);
- the essential components of the boiler and/or antifreeze kit are not faulty.

The warranty does not cover damage due to interruption of the electrical power supply and failure to comply with that stated on the previous page.

NOTE: if the boiler is installed in places where the temperature falls below 0°C the domestic hot water and central heating attachment pipes must be insulated.

1.4 GAS CONNECTION.

Our boilers are designed to operate with methane gas (G20) and L.P.G. Supply pipes must be the same as or larger than the 3/4" G boiler fitting. Before connecting the gas line, carefully clean inside all the fuel feed system pipes to remove any residue that could impair boiler efficiency. Also make sure the gas corresponds to that for which the boiler is prepared (see boiler data name plate). If different, the appliance must be converted for operation with the other type of gas (see converting appliance for other gas types). The dynamic gas supply (methane or LPG) pressure must also be checked according to the type used in the boiler, which must comply with the technical standards in force, as insufficient levels can reduce generator output and cause malfunctions.

Ensure correct gas cock connection. The gas supply pipe must be suitably dimensioned according to current regulations in order to guarantee correct gas flow rate to the burner even in conditions of maximum generator output and to guarantee appliance efficiency (technical specifications). The coupling system must conform to technical standards in force.

Fuel gas quality. The appliance was designed to operate with combustible gas free of impurities; otherwise it is advisable to fit special filters upstream of the appliance to restore the purity of the fuel.

Storage tanks (in case of supply from LPG depot).

- New LPG storage tanks may contain residual inert gases (nitrogen) that degrade the mixture delivered to the appliance causing functioning anomalies.
- Due to the composition of the LPG mixture, layering of the mixture components may occur during the period of storage in the tanks. This can cause a variation in the heating power of the mixture delivered to the appliance, with subsequent change in its performance.

1.5 HYDRAULIC CONNECTION.

Attention: in order not to void the condensation module warranty, before making the boiler connections, carefully wash the heating system (pipes, radiators, etc.) with special pickling or descaling products to remove any deposits that could compromise correct boiler operation.

A chemical treatment of the heating and water system water is required, in compliance with the technical standards in force, in order to protect the system and the appliance from deposits (e.g. scale), slurry or other hazardous deposits.

Water connections must be made in a rational way using the couplings on the boiler template. The boiler safety valve outlet must be connected to a draining funnel. Otherwise, the manufacturer declines any responsibility in case of flooding if the drain valve cuts in.

Attention: Immergas declines all liability in the event of damage caused by the inclusion of automatic filling that is not its own brand.

In order to meet the system requirements established by the technical regulation in force in relation to the pollution of drinking water, we recommend installing the IMMERGAS anti-backflow kit to be used upstream of the cold water inlet connection of the boiler. It is also recommended that the heat transfer fluid (e.g. water + glycol) entered in the primary circuit of the boiler (heating circuit), complies with the local regulations in force.

Attention: to preserve the duration and the efficiency features of the appliance, in the presence of water whose features can lead to the deposit of scale, installation of the "polyphosphate dispenser" kit is recommended.

Condensate drain. To drain the condensate produced by the appliance, it is necessary to connect to the drainage system by means of acid condensate resistant pipes, with an internal Ø of at least 13 mm. The system connecting the appli-

ance to the drainage system must be carried out in such a way as to prevent freezing of the liquid contained in it. Before appliance ignition, ensure that the condensate can be correctly removed. After first ignition, check that the drain trap is filled with condensate (para. 1.21). Also, comply with national and local regulations on discharging waste waters. In the event condensate is not discharged into the wastewater drainage system, a condensate neutraliser must be installed to ensure compliance with the parameters established by the legislation in force.

1.6 ELECTRICAL CONNECTION.

The "Victrix EXA 28 1 ErP - 32 1 ErP" boiler has an IPX4D protection rating for the entire appliance. Electrical safety of the appliance is reached only when it is correctly connected to an efficient earthing system as specified by current safety standards.

Attention: Immergas S.p.A. declines any responsibility for damage or physical injury caused by failure to connect the boiler to an efficient earth system or failure to comply with the reference standards.

- **Open the control panel connections compartment (Fig. 1-4).**

To carry out electrical connections, all you have to do is open the connections compartment as follows.

- Disassemble the grid (Fig. 3-5a).
- Remove the caps, loosen the fastening screws and pull the front panel (c) towards you (Fig. 3-5b).
- Remove the cover (b fig. 1-4).
 - 1) Loosen the screws (a).
 - 2) Remove the cover (b) from the control panel (c).
- At this point, it is possible to access the terminal board (d).

Also ensure that the electrical installation corresponds to maximum absorbed power specifications as shown on the boiler data nameplate. Boilers are supplied complete with an "X" type power cable without plug. The power supply cable must be connected to a 230V ±10% / 50Hz mains supply respecting L-N polarity and earth connection; ⚡ this network must also have a multi-pole circuit breaker with class III over-voltage category. When replacing the power supply cable, contact a qualified firm (e.g. the Authorised After-Sales Technical Assistance Service). The power cable must be laid as shown (Fig. 1-3).

In the event of mains fuse replacement on the P.C.B., use a 3.15A quick-blow fuse. For the main power supply to the appliance, never use adapters, multiple sockets or extension leads.

Installation with system operating at direct low temperature. The boiler can directly feed a low-temperature system by acting on parameters "S5" and "S6" (par. 3.8). In this situation it is good practice to insert a relevant safety kit (optional) made up from a thermostat (with adjustable temperature). The thermostat must be positioned on the system flow pipe.

Attention: when installing the connection kit (optional), it is compulsory to insert a flat gasket on the gas and hot water outlet fittings.

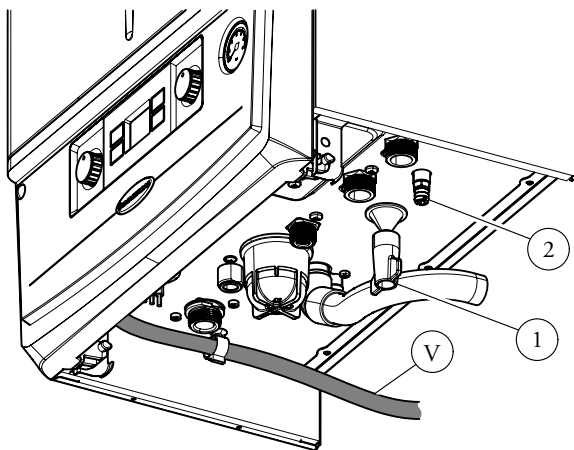

Key:
 V - Electrical connection
 1 - Filling cock
 2 - Draining valve

1-3

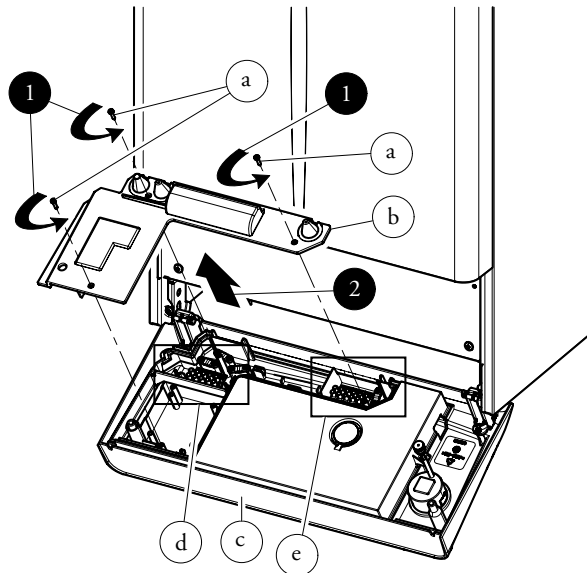

1-4

1.7 REMOTE CONTROLS AND ROOM CHRONO-THERMOSTATS (OPTIONAL).

The boiler is prepared for the application of room chrono-thermostats or remote controls, which are available as optional kits. (Fig. 1-5)

All Immergas chrono-thermostats are connected with 2 wires only. Carefully read the user and assembly instructions contained in the accessory kit.

- On/Off Immergas digital chrono-thermostat. The chrono-thermostat allows:
 - set two room temperature value: one for daytime (comfort temperature) and one for night-time (reduced temperature);
 - set a weekly program with four daily switch on and switch off times;
 - select the required operating mode from the various possible alternatives:
 - manual mode (with adjustable temperature).
 - automatic mode (with set program).
 - forced automatic mode (momentarily changing the temperature of the automatic program).

The chrono-thermostat is powered by two 1.5V LR 6 type alkaline batteries.

- Comando Amico Remoto Remote Control Device ^{V2} (CAR^{V2}) with climate chrono-thermostat function. In addition to the functions described in the previous point, the CAR^{V2} panel enables the user to control all the important information regarding operation of the appliance and the heating system with the opportunity to easily intervene on the previously set parameters, without having to go to where the appliance is installed. The panel is provided with self-diagnosis to display any boiler functioning

anomalies. The climate chrono-thermostat incorporated into the remote panel enables the system flow temperature to be adjusted to the actual needs of the room being heated, in order to obtain the desired room temperature with extreme precision and therefore with evident saving in running costs. The CAR^{V2} is fed directly by the boiler by means of the same 2 wires used for the transmission of data between the boiler and device.

Important: if the system is subdivided into zones using the relevant kit, the CAR^{V2} must be used with its climate thermostat function disabled, i.e. it must be set to On/Off mode.

CAR^{V2} or chrono-thermostat On/Off electric connection (Optional). *The operations described below must be performed after having removed the voltage from the appliance.* Any On/Off room chrono-thermostat must be connected to clamps 40 and 41 eliminating jumper X40 (Fig. 3-2). Make sure that the On/Off thermostat contact is of the "clean" type, i.e. independent of the mains voltage, otherwise the P.C.B. would be damaged. CAR^{V2} must be connected to terminal boards 41 and 44, eliminating jumper X40 on the terminal board (located in the control panel) (Part. e Fig. 1-4) paying attention not to invert the polarity connections (Fig. 3-2). Connection with the wrong polarity prevents functioning, but without damaging the CAR^{V2}. The boiler can only be connected to one remote control.

Important: if the CAR^{V2} remote control is used, arrange two separate lines in compliance with current regulations regarding electrical systems. No boiler pipes must ever be used to earth the electric system or telephone lines. Ensure elimination of this risk before making the boiler electrical connections.

1.8 EXTERNAL PROBE (OPTIONAL).

The boiler is designed for the application of the external temperature probe (Fig. 1-6), which is available as an optional kit. Refer to the relative instruction sheet for positioning of the external probe.

The probe can be connected directly to the boiler electrical system and allows the max. system flow temperature to be automatically decreased when the external temperature increases, in order to adjust the heat supplied to the system according to the change in external temperature. The external probe always operates when connected, regardless of the presence or type of room chrono-thermostat used and can work in combination with Immergas chrono-thermostats. The correlation between system flow temperature and external temperature is determined by the position of the central heating selector switch on the boiler control panel (or on the CAR^{V2} control panel if connected to the boiler) according to the curves shown in the diagram (Fig. 1-7).

The electric connection of the external probe must be made on clamps 38 and 39 on the terminal board in the control panel (Part. d Fig. 1-4).

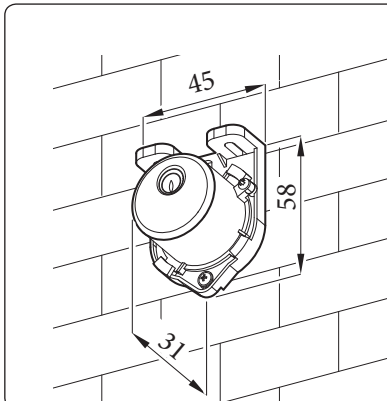
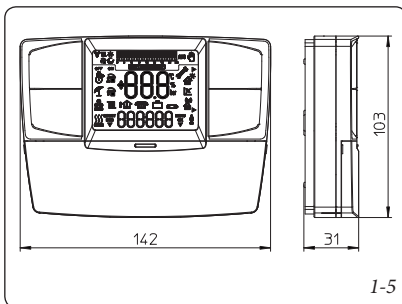

EXTERNAL PROBE
Correction law of the flow temperature depending on the external temperature and user adjustments of the central heating temperature.

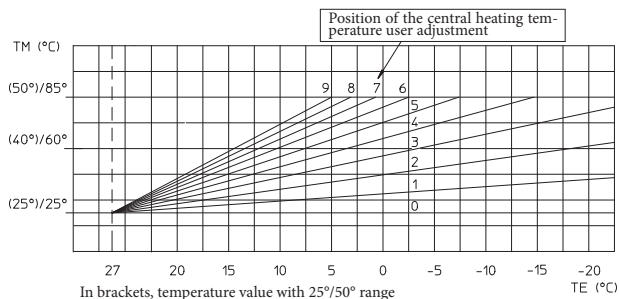

1.9 IMMERGAS FLUE SYSTEMS.

Immergas supplies various solutions separately from the boilers regarding the installation of air intake terminals and flue exhaust, which are fundamental for boiler operation.

Attention: the boiler must be installed exclusively with an original Immergas “Green Range” inspectionable air intake system and fumes extraction system made of plastic, with the exception of the C6 configuration, as required by the regulations in force.

The plastic pipes cannot be installed outdoors, for tracts longer than 40 cm, without suitable protection from UV rays and other atmospheric agents.

This system can be identified by an identification mark and special distinctive marking bearing the note: “only for condensing boilers”.

- Resistance factors and equivalent lengths. Each flue component has a *Resistance Factor* based on experimental tests and specified in the table below. The Resistance Factor for individual components is independent from the type of boiler on which it is installed and has a dimensionless size. It is however, conditioned by the temperature of the fluids that pass through the pipe and therefore, varies according to applications for air intake or flue exhaust. Each single component has a resistance corresponding to a certain length in metres of pipe of the same diameter; the so-called *equivalent length*, can be obtained from the ratio between the relative Resistance Factors. *All boilers have an experimentally obtainable maximum Resistance Factor equal to 100.* The maximum Resistance Factor allowed corresponds to the resistance encountered with the maximum allowed pipe length for each type of Terminal Kit. This information allows calculations to be made to verify the possibility of setting up various flue configurations.

- Positioning the gaskets (black) for “green range” flue systems. Position the gasket correctly (for bends and extensions) (Fig. 1-8):

- gasket (A) with notches, to use for bends;
- gasket (B) without notches, to use for extensions;

N.B.: if necessary, to ease the push-fitting, spread the elements with commonly-used talc.

- Coupling extension pipes and concentric elbows. To install push-fitting extensions with other elements of the flue, proceed as follows: Install the concentric pipe or elbow with the male side (smooth) on the female side (with lip seal) to the end stop on the previously installed element in order to ensure sealing efficiency of the coupling.





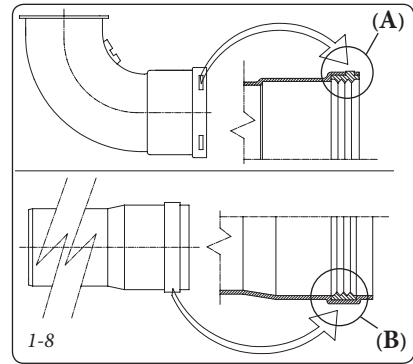





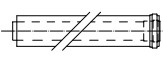

Attention: if the exhaust terminal and/or concentric extension pipe needs shortening, consider that the internal duct must always protrude by 5 mm with respect to the external duct.

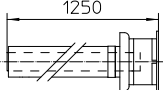
- N.B.:** for safety purposes, do not obstruct the boiler intake/exhaust terminal, even temporarily.
- N.B.:** when installing horizontal pipes, a minimum inclination of 3% must be maintained and a section clip with pin must be installed every 3 metres.

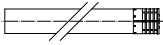

1.10 TABLES OF RESISTANCE FACTORS AND EQUIVALENT LENGTHS.

TYPE OF DUCT		Resistance Factor (R)	Equivalent length in m of concentric pipe Ø 80/125
Concentric pipe Ø 80/125 m 1		2.1	1
Concentric bend 90° Ø 80/125		3.0	1.4
Concentric bend 45° Ø 80/125		2.1	1
Terminal complete with concentric horizontal intake-exhaust Ø 80/125		2.8	1.3
Terminal complete with concentric vertical intake-exhaust Ø 80/125		3.6	1.7
Concentric bend 90° Ø 80/125 with inspection		3.4	1.6
Stub pipe with inspection Ø 80/125		3.4	1.6

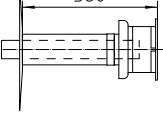
TYPE OF DUCT		Resistance Factor (R)	Equivalent length in m of concentric pipe Ø 60/100	Equivalent length in metres of pipe Ø 80	Equivalent length in metres of pipe Ø 60	Equivalent length in m of concentric pipe Ø 80/125
Concentric pipe Ø 60/100 m 1		Intake and Exhaust 6.4	m 1	Intake m 7.3	Exhaust m 1.9	m 3.0
				Exhaust m 5.3		
Concentric bend 90° Ø 60/100		Intake and Exhaust 8.2	m 1.3	Intake m 9.4	Exhaust m 2.5	m 3.9
				Exhaust m 6.8		
Concentric bend 45° Ø 60/100		Intake and Exhaust 6.4	m 1	Intake m 7.3	Exhaust m 1.9	m 3.0
				Exhaust m 5.3		
Terminal complete with concentric horizontal intake-exhaust Ø 60/100		Intake and Exhaust 15	m 2.3	Intake m 17.2	Exhaust m 4.5	m 7.1
				Exhaust m 12.5		
Concentric horizontal intake- exhaust terminal Ø 60/100		Intake and Exhaust 10	m 1.5	Intake m 11.5	Exhaust m 3.0	m 4.7
				Exhaust m 8.3		
Terminal complete with concentric vertical intake-exhaust Ø 60/100		Intake and Exhaust 16.3	m 2.5	Intake m 18.7	Exhaust m 4.9	m 7.7
				Exhaust m 13.6		
Concentric vertical intake-exhaust terminal Ø 60/100		Intake and Exhaust 9	m 1.4	Intake m 10.3	Exhaust m 2.7	m 4.3
				Exhaust m 7.5		
Pipe Ø 80 m 1		Intake 0.87	m 0.1	Intake m 1.0	Exhaust m 0.4	m 0.4
		Exhaust 1.2	m 0.2	Exhaust m 1.0		m 0.5
Complete intake terminal Ø 80 m 1		Intake 3	m 0.5	Intake m 3.4	Exhaust m 0.9	m 1.4
Intake terminal Ø 80 Exhaust terminal Ø 80		Intake 2.2	m 0.35	Intake m 2.5	Exhaust m 0.6	m 1
		Exhaust 1.9	m 0.3	Exhaust m 1.6		m 0.9
Bend 90° Ø 80		Intake 1.9	m 0.3	Intake m 2.2	Exhaust m 0.8	m 0.9
		Exhaust 2.6	m 0.4	Exhaust m 2.1		m 1.2
Bend 45° Ø 80		Intake 1.2	m 0.2	Intake m 1.4	Exhaust m 0.5	m 0.5
		Exhaust 1.6	m 0.25	Exhaust m 1.3		0.7
Pipe Ø 60 m 1 for ducting		Exhaust 3.3	m 0.5	Intake 3.8	Exhaust m 1.0	m 1.5
				Exhaust 2.7		
Bend 90° Ø 60 for ducting		Exhaust 3.5	m 0.55	Intake 4.0	Exhaust m 1.1	m 1.6
				Exhaust 2.9		
Reduction Ø 80/60		Intake and Exhaust 2.6	m 0.4	Intake m 3.0	Exhaust m 0.8	m 1.2
				Exhaust m 2.1		
Terminal complete with exhaust vertical Ø 60 for ducting		Exhaust 12.2	m 1.9	Intake m 14	Exhaust m 3.7	m 5.8
				Exhaust m 10.1		

1.11 OUTDOOR INSTALLATION IN A PARTIALLY PROTECTED AREA.

N.B.: a partially protected location is one in which the appliance is not exposed to the direct action of the weather (rain, snow, hail, etc.).

This type of installation is only possible when permitted by the laws in force in the appliance's country of destination.

• Configuration type B, open chamber and forced draught.

Using the special coverage kit one can achieve direct air intake (Fig. 1-9) and fumes exhaust in a single flue or directly outside. In this configuration it is possible to install the boiler in a partially protected place. In this configuration the boiler is classified as type B.

With this configuration:

- air intake takes place directly from the environment in which the appliance is installed (outside);
- the fumes exhaust must be connected to its own single flue (B23) or ducted directly outside via a vertical terminal for direct exhaust (B₅₃) or via an Immergas ducting system (B₅₃).

The technical regulations in force must be respected.

- **Coverage kit assembly (Fig. 1-10).** Remove the two plugs and the gaskets present from the two lateral holes with respect to the central one. Now cover the right intake hole using the relevant plate, fixing it onto the left side using the 2 previously-removed screws. Install the Ø 80 outlet flange on the central hole of the boiler, taking care to insert the gasket supplied with the kit and tighten by means of the screws provided. Install the upper cover, fixing it using the 4 screws present in the kit, positioning the relevant gaskets. Engage the 90° Ø 80 bend with the male end (smooth) in the female end (with lip seal) of the Ø 80 flange unit until it stops. Introduce the gasket, making it run along the bend. Fix it using the metal sheet plate and tighten by means of the clips present in the kit, making sure to block the 4 gasket flaps. Fit the male end (smooth) of the exhaust terminal into the female end of the bend 90° Ø 80, mak-

ing sure that the relevant wall sealing plate is already fitted; this will ensure hold and joining of the elements making up the kit.

Max. length of exhaust duct. The flue pipe (both vertical or horizontal) can be extended to a max. length of 30 linear metres.

- **Coupling of extension pipes.** To install any push-fit extensions with other flue elements, it is necessary to act as follows: install the pipe or elbow with the male side (smooth) into the female section (with lip seal) to the end stop on the previously installed element. This will ensure correct sealing and joining of the elements.

• Configuration without cover kit in a partially protected location (type C boiler)

By leaving the side plugs fitted it is possible to install the appliance externally without the cover kit. Installation takes place using the Ø60/100, Ø 80/125 and separator Ø 80/80 concentric intake/ exhaust kits. Refer to the paragraph relative to indoor installation. In this configuration the upper cover kit guarantees additional protection for the boiler. It is recommended but not compulsory.

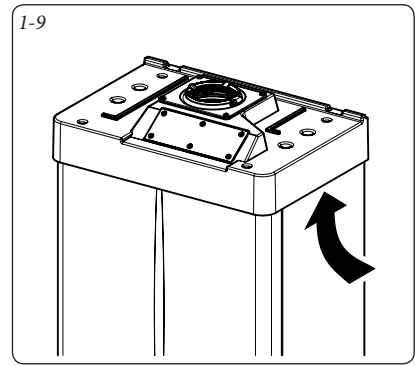

INSTALLER

USER

MAINTENANCE TECHNICIAN

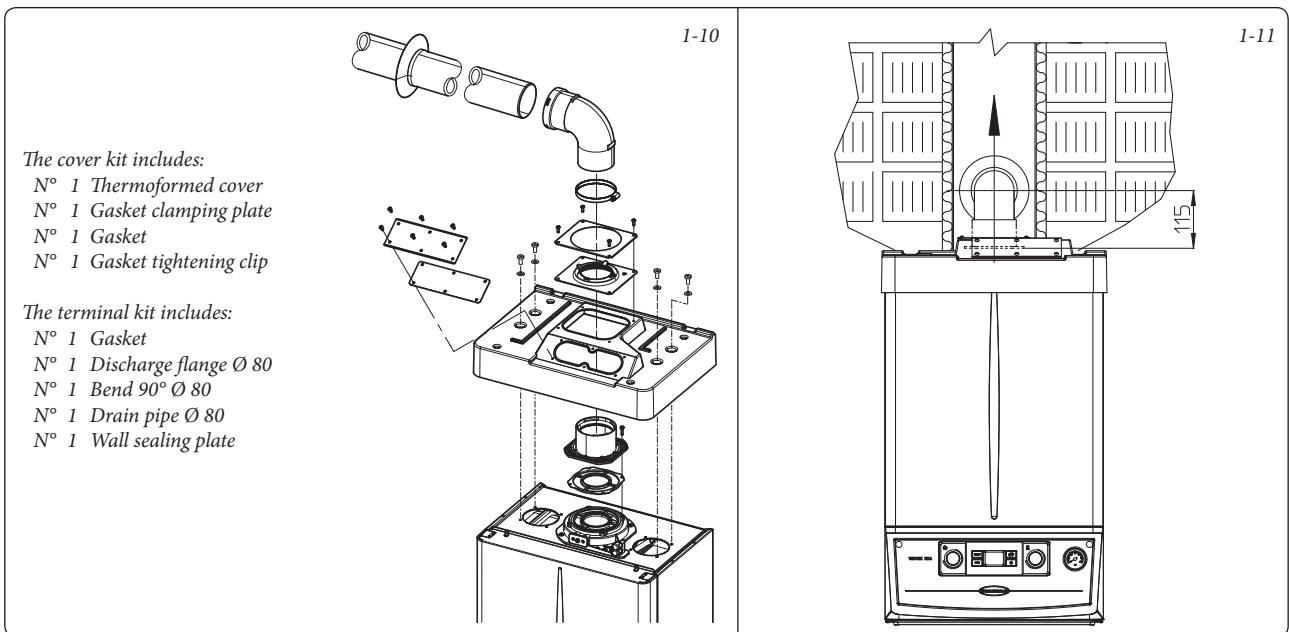

- The cover kit includes:
- N° 1 Thermoformed cover
 - N° 1 Gasket clamping plate
 - N° 1 Gasket
 - N° 1 Gasket tightening clip
- The terminal kit includes:
- N° 1 Gasket
 - N° 1 Discharge flange Ø 80
 - N° 1 Bend 90° Ø 80
 - N° 1 Drain pipe Ø 80
 - N° 1 Wall sealing plate

1.12 INTERNAL INSTALLATION USING A RECESSED FRAME WITH DIRECT AIR INTAKE

- Configuration type B, open chamber and forced draught.

Using a kit separator one can achieve direct air intake (Fig. 1-12) and fumes exhaust in a single flue or directly outside. In this configuration the boiler is classified as type B₂₃.

With this configuration:

- air intake takes place directly from the environment in which the appliance is installed (the recessed frame is ventilated), and only functions in permanently ventilated rooms;
- the flue exhaust must be connected to its own individual flue or channeled directly into the external atmosphere.

The technical regulations in force must be respected.

Separator kit installation: install the discharge flange on the central hole of the boiler, positioning the relative gasket with the circular projections downwards in contact with the boiler flange, and tighten using the hex screws with flat tip contained in the kit. Remove the flat flange present in the lateral hole with respect to the central one (according to needs) and replace it with the intake flange, positioning its gasket already present in the boiler and tighten using the supplied self-threading screws. Fit the male side (smooth) to the bends in the female side of the flanges.

The intake bend must face the rear side of the boiler.

Fit the exhaust pipe with the male side (smooth) to the female side of the bend up to the end stop, making sure that the internal wall sealing plate has been fitted and connecting the required flue according to personal requirements.

Max. length of exhaust duct. The flue pipe (both vertical or horizontal) can be extended to a max. length of 30 linear metres.

1-12

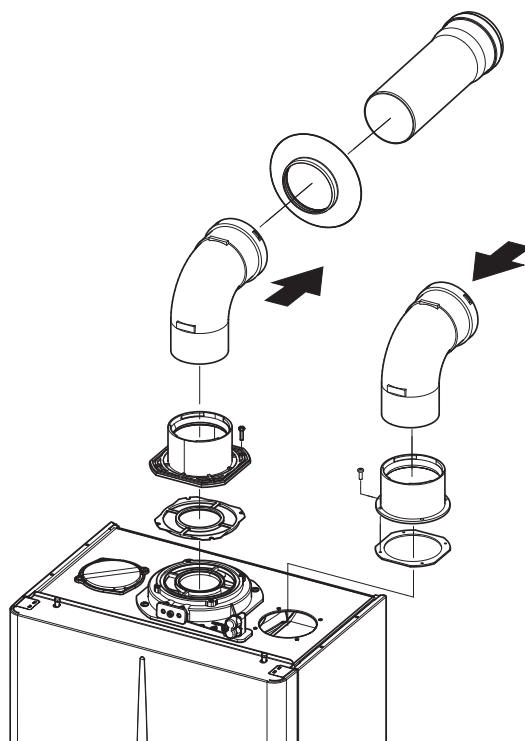

1.13 CONCENTRIC HORIZONTAL KIT INSTALLATION.

Type C configuration, sealed chamber and fan assisted.

The position of the terminal (in terms of distances from openings, overlooking buildings, floor, etc.) must be in compliance with the regulations in force.

This terminal can also be used without functional and suitable, or adaptable, chimneys / flues / combustion products exhaust systems and using low-emission heat generators (class 5a, according to the technical regulations in force), in the following cases:

- "individual renovation of autonomous systems in buildings consisting of several housing units";
- "new installations of individual heating systems in buildings undergoing conservative interventions."

This terminal is connected directly to the outside of the building for air intake and flue exhaust. The horizontal kit can be installed with the rear, right side, left side or front outlet. For installation with frontal outlet, one must use the fixing plate and a concentric bend coupling in order to ensure sufficient space to carry out the tests required by law upon commissioning.

- External grid. Both the Ø 60/100 and Ø 80/125 intake/exhaust terminal, if properly installed, is pleasant to look at on the outside of the building. Make sure that the external silicone wall sealing plate is properly inserted in the wall.

N.B.: for proper system operation the terminal with grid must be installed correctly ensuring that, the "high" indication on the terminal is observed during installation.

Horizontal intake-exhaust kit Ø 60/100 Kit assembly (Fig. 1-13): install the bend with flange (2) on the central hole of the boiler, positioning gasket (1) with the circular projections downwards in contact with the boiler flange, and tighten using the screws present in the kit. Fit the Ø 60/100 (3) concentric terminal pipe with the male side (smooth) to the female side of the bend (2) up to the end stop; making sure that the internal and external wall sealing plate have been fitted, this will ensure sealing and joining of the elements making up the kit.

- Extensions for Ø 60/100 horizontal kit (Fig. 1-14). The kit with this configuration can be extended up to a *max. 12.9 horizontal m* including the terminal with grid and excluding the concentric bend leaving the boiler. This configuration corresponds to a resistance factor of 100. In this case the special extensions must be requested.

Immergas also provides a Ø 60/100 simplified terminal, which in combination with its extension kits allows you to reach a maximum extension of 11.9 metres.

Horizontal intake-exhaust kit Ø 80/125 Kit assembly (Fig. 1-15): to install the kit Ø 80/125 one must use the flanged adaptor kit in order to install the flue system Ø 80/125. Install the flanged adaptor (2) on the central hole of the boiler, positioning gasket (1) with the circular projections downwards in contact with the boiler flange, and tighten using the screws contained in the kit. Engage the bend (3) with the male side (smooth) to the end stop on the adaptor (1). Fit the Ø 80/125 (5) concentric terminal pipe with the male side (smooth) to the female side of the bend (4) (with lip seals) up to the end top; making sure that the internal (6) and external wall sealing plate (7) have been fitted, this will ensure sealing and joining of the elements making up the kit.

- Extensions for horizontal kit Ø 80/125 (Fig. 1-16). The kit with this configuration can be extended up to a *max. length of 32 m*, including the terminal with grid and excluding the concentric bend leaving the boiler. If additional components are assembled, the length equivalent to the maximum allowed must be subtracted. In this case the special extensions must be requested.

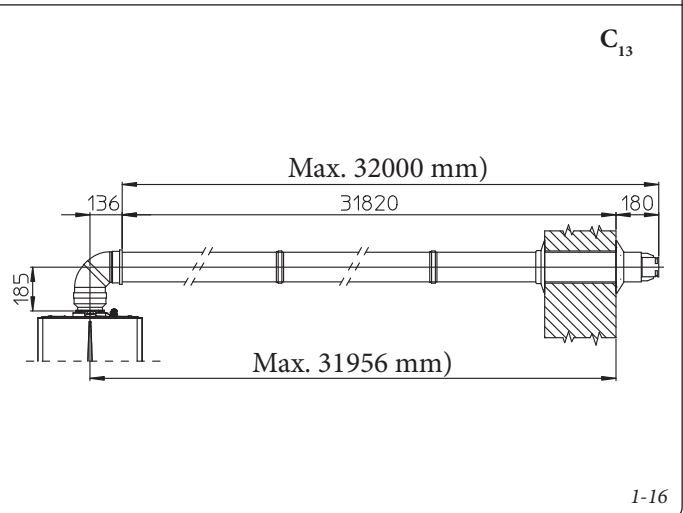
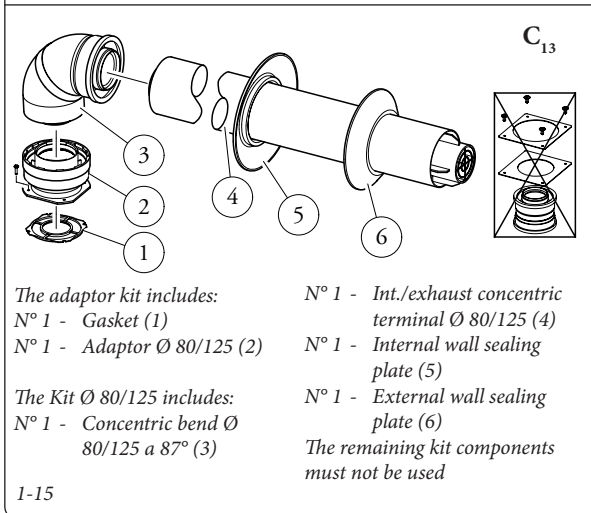
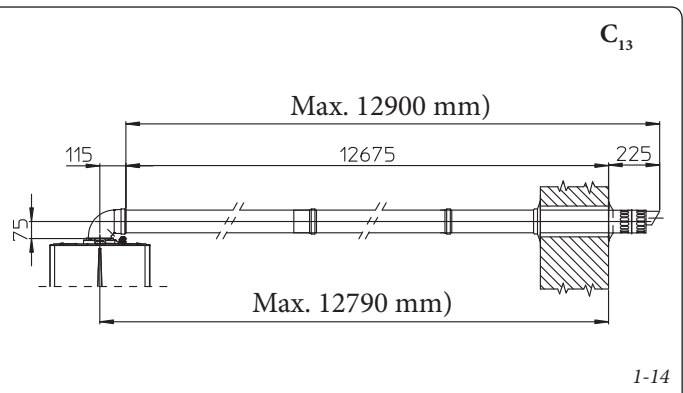
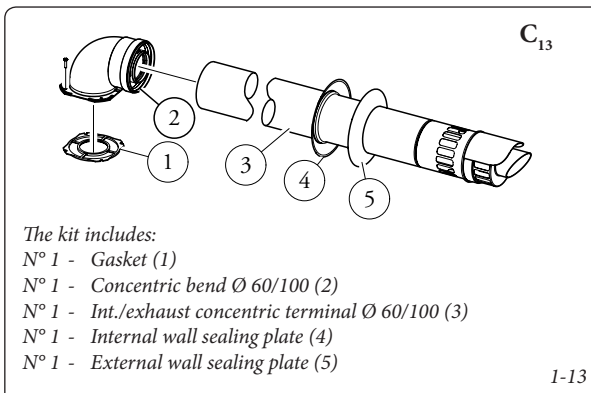

1.14 CONCENTRIC VERTICAL KIT INSTALLATION.

Type C configuration, sealed chamber and fan assisted.

Concentric vertical intake and exhaust kit. This vertical terminal is connected directly to the outside of the building for air intake and flue exhaust.

N.B.: the vertical kit with aluminium tile enables installation on terraces and roofs with a maximum slope of 45% (approx 25°) and the height between the terminal cap and half-shell (374 mm for Ø 60/100 and 260 mm for Ø 80/125) must always be observed.

Vertical kit with aluminium tile Ø 60/100.

Kit assembly (Fig. 1-17): install the concentric flange (2) on the central hole of the boiler, positioning gasket (1) with the circular projections downwards in contact with the boiler flange, and tighten using the screws contained in the kit. Installation of the fake aluminium tile: replace the tiles with the aluminium sheet (4), shaping it to ensure that rainwater runs off. Position the fixed half-shell (6) on the aluminium tile and insert the intake-exhaust pipe (5). Fit the Ø 60/100 (3) concentric terminal pipe with the

male side (5) (smooth) into the flange (2) up to the end stop; making sure that the wall sealing plate has been fitted (3), this will ensure sealing and joining of the elements making up the kit.

NOTE: when the boiler is installed in areas where very cold temperatures can be reached, a special anti-freeze kit is available that can be installed as an alternative to the standard kit.

- Extensions for vertical kit Ø 60/100 (Fig. 1-18). The kit with this configuration can be extended to a max. straight vertical length of 14.4 m, including the terminal. This configuration corresponds to a resistance factor of 100. In this case specific extensions must be requested.

Vertical kit with aluminium tile Ø 80/125.

Kit assembly (Fig. 1-19): to install the kit Ø 80/125 one must use the flanged adaptor kit in order to install the flue system Ø 80/125. Install the flanged adaptor (2) on the central hole of the boiler, positioning gasket (1) with the circular projections downwards in contact with the boiler flange and tighten using the screws contained in the kit. Installation of the fake aluminium tile: replace the tiles with the aluminium sheet (4), shaping it to ensure that rainwater runs off.

Position the fixed half-shell (5) on the aluminium tile and insert the intake-exhaust pipe (7). Fit the Ø 80/125 concentric terminal pipe with the male side (smooth) to the female side of the adapter (1) (with lip gaskets) up to the end stop; making sure that the wall sealing plate (3) has been fitted, this will ensure sealing and joining of the elements making up the kit.

- Extensions for vertical kit Ø 80/125 (Fig. 1-20). The kit with this configuration can be extended up to a max. length of 32 m including the terminal. If additional components are assembled, the length equivalent to the maximum allowed must be subtracted. In this case specific extensions must be requested.

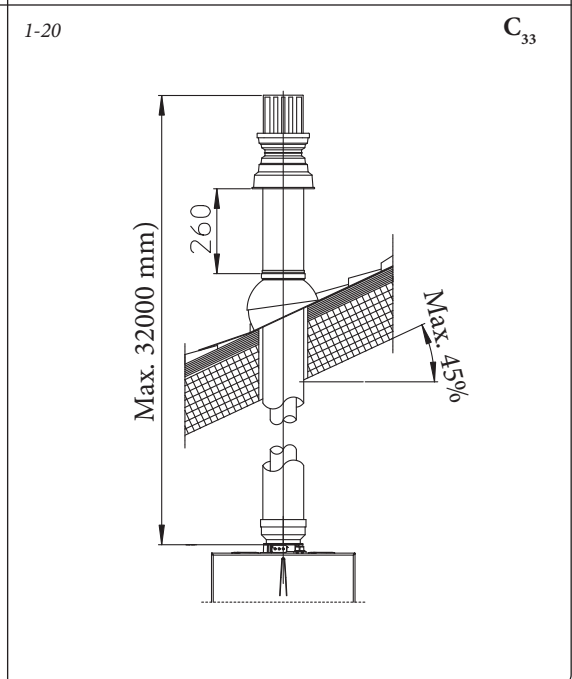
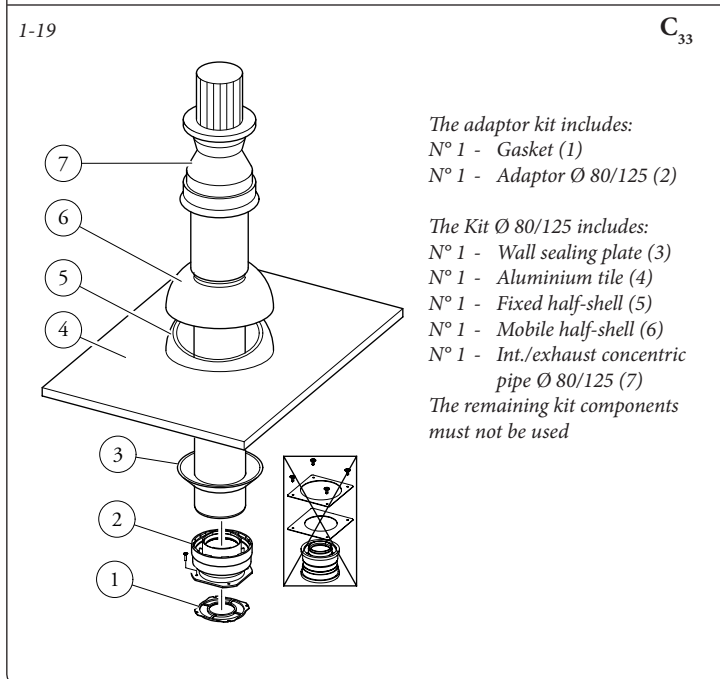
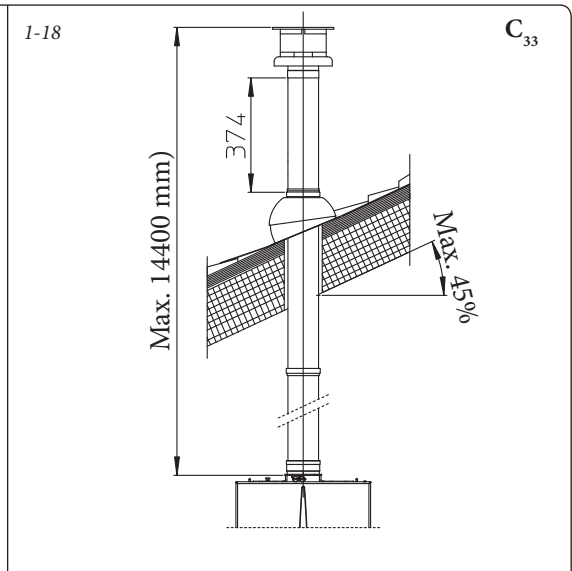
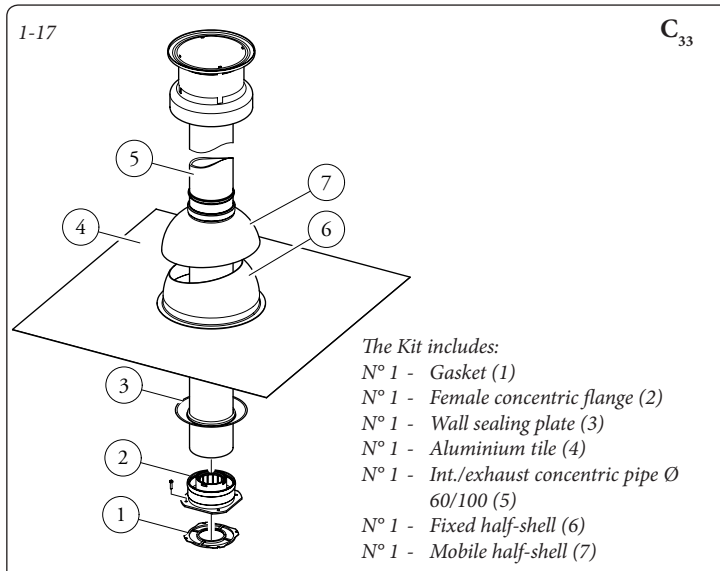

1.15 SEPARATOR KIT INSTALLATION.
Type C configuration, sealed chamber and fan assisted.

Separator kit Ø 80/80. This kit allows air to come in from outside the building and the exhaust to exit from the chimney, flue or intubated duct through divided flue exhaust and air intake pipes. Combustion products are expelled from pipe (S) (in plastic, so as to resist acid condensate). Air is taken in through duct (A) for combustion (this is also in plastic). The intake pipe (A) can be installed either on the right or left hand side of the central exhaust pipe (S). Both ducts can be routed in any direction.

- Kit assembly (Fig. 1-21): install flange (4) on the central hole of the boiler, positioning gasket (1) with the circular projections downwards in contact with the boiler flange, and tighten using the hex screws with flat tip contained in

the kit. Remove the flat flange present in the lateral hole with respect to the central one (according to needs) and replace it with the flange (3), positioning the gasket (2) already present in the boiler and tighten using the supplied self-threading screws. Fit the male end (smooth) to the bends (5) in the female end of the flanges (3 and 4). Fit the intake terminal (6) with the male side (smooth) in the female side of the bend (5) up to the end stop, ensuring that the internal and external wall sealing plates are fitted. Fit the exhaust pipe (9) with the male side (smooth) to the female side of the bend (5) up to the end stop; making sure that the internal wall sealing plate has been fitted, this will ensure sealing and joining of the elements making up the kit.

- Installation clearances (Fig. 1-22). The minimum installation clearance measurements of the Ø 80/80 separator terminal kit have been

stated in some limit conditions.

- Extensions for separator kit Ø 80/80. The maximum vertical straight length (without bends) that can be used for Ø 80 intake and exhaust pipes is 41 metres, regardless from whether they are used for intake or exhaust. The maximum horizontal straight length (with bend in suction and in exhaust) that can be used for Ø 80 intake and exhaust pipes is 36 metres, regardless from whether they are used for intake or exhaust.

N.B.: to favour the removal of possible condensate forming in the exhaust pipe, tilt the pipes towards the boiler with a minimum slope of 1.5% (Fig. 1-23).

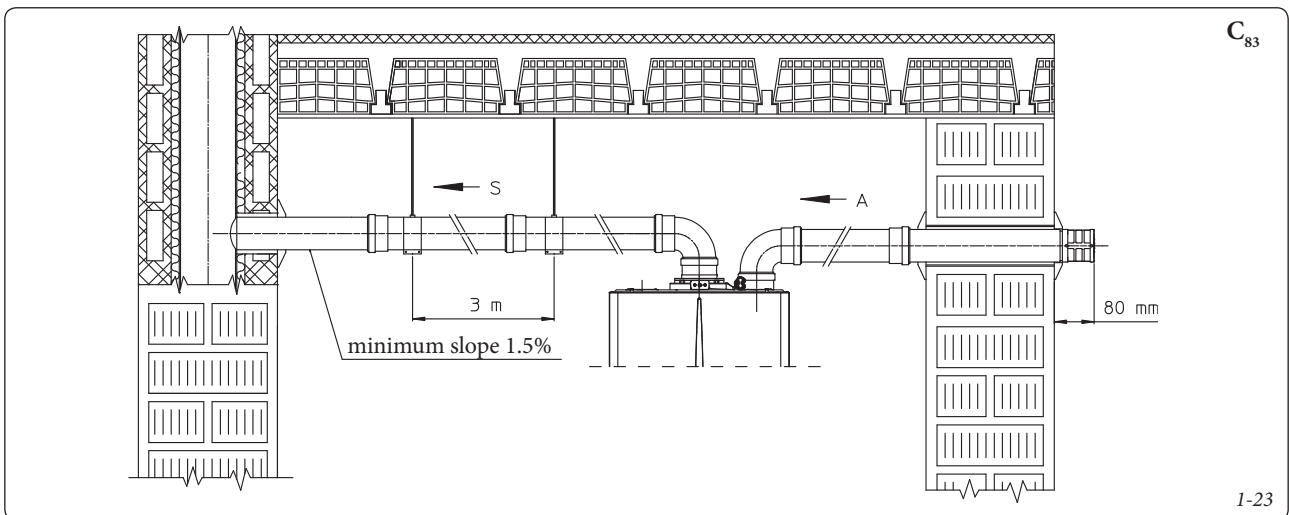
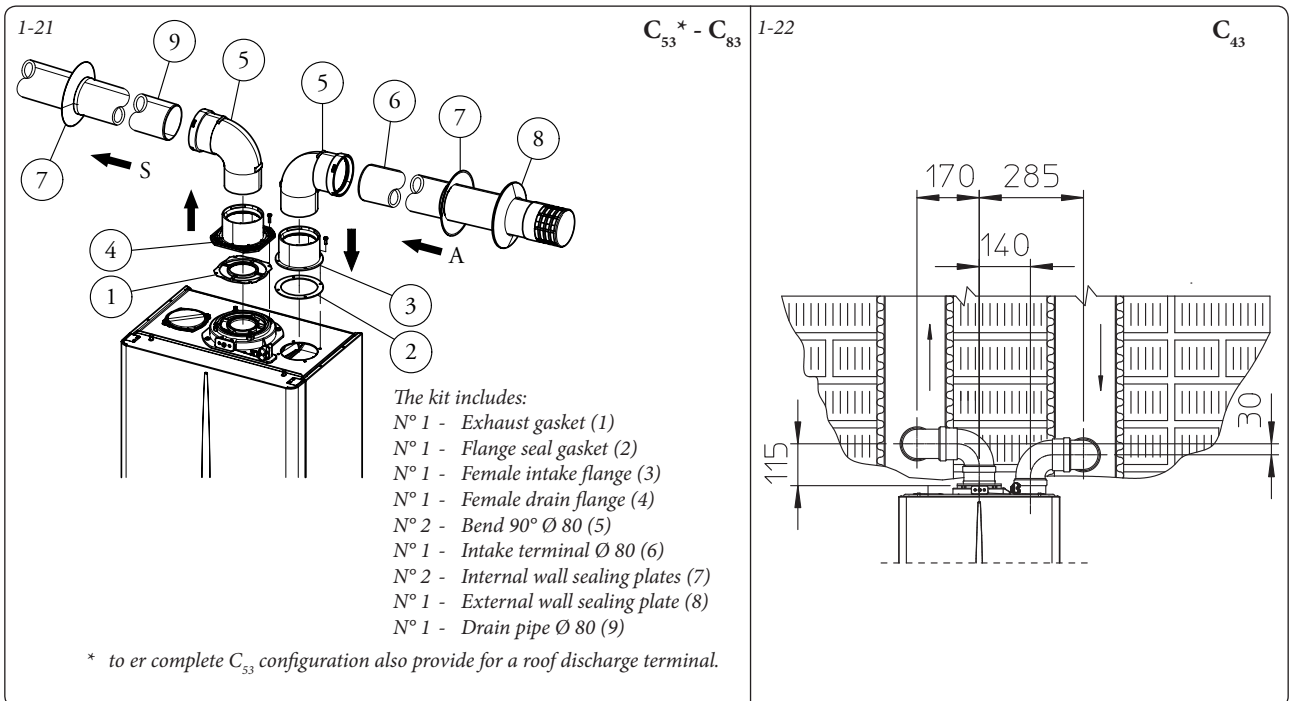

1.16 ADAPTOR C9 KIT INSTALLATION.

This kit allows an Immergas boiler to be installed in "C₉₃" configuration, with combustion air intake directly from the shaft where the flue gas exhaust is, obtained by means of a ducting system.

System composition.

The system must be combined with the following components (sold separately) to be functional and complete:

- kit C₉₃ Ø 100 or Ø125 version
- ducting kit Ø 60 or Ø 80
- fumes exhaust kit Ø 60/100 or Ø 80/125 configured according to the installation and type of boiler.

Kit Assembly.

- Mount the components of kit "C9" on the door (A) of the ducting system (Fig. 1-25).
- (Version Ø 125 only) mount the flanged adaptor (11) interposing the concentric gasket (10) on the boiler, fitting it with the screws (12).
- Mount the ducting system as described in the relative instructions sheet.
- Calculate the distances between the boiler drain and the bend of the ducting system.
- Prepare the boiler flue system, making sure that the internal pipe of the concentric kit is fitted up to the end stop in the ducting system curve (quota "X" Fig. 1-26), whereas the external pipe must reach the end stop of the adaptor (1).

N.B.: to encourage the removal of possible condensate forming in the exhaust pipe, tilt the pipes towards the boiler with a minimum slope of 1.5%.

- Mount the cover (A) complete with adaptor (1) and caps (6) on the wall and assemble the flue system to the ducting system.

N.B.: (version Ø 125 only) before assembly check the gaskets are in the right position. In the event component lubrication (already carried out by the manufacturer) is not sufficient, remove the residual lubricant using a dry cloth, then to ease fitting coat the parts with common or industrial talc.

Once all components have been assembled properly, the exhaust fumes will be expelled via the ducting system; the combustion air for normal boiler operation will be aspirated directly by the shaft (Fig. 1-26).

Technical data.

- The dimensions of the shafts must ensure a minimum gap between the outer wall of the smoke duct and the inner wall of the shaft: 30 mm for circular section shafts and 20 mm in the event of a square section shaft (Fig. 1-24).
- Maximum 2 changes of direction are allowed on the vertical section of the flue system with a maximum clearance angle of 30° with respect to the vertical.
- The maximum vertical extension using a Ø 60 ducting system is 13 m, the maximum extension includes 1 bend Ø 60/10 at 90°, 1 m of horizontal pipe 60/100, 1 90° ducted bend Ø 60 and the roof terminal for ducting.

To determine the C₉₃ flue system in configurations other than that described (Fig. 1-26) one must consider that 1 metre of ducted pipe

according to the indications described has a resistance factor equal to 4.9.

- The maximum vertical extension using a Ø 80 ducting system is 28 m, the maximum extension includes 1 adaptor 60/100 to 80/125, 1 87° bend Ø 80/125, 1 m of horizontal pipe 80/125, 1 90° ducted bend Ø 80 and the roof terminal for ducting.

To determine the C₉₃ flue system in configurations other than that described (Fig. 1-26) one must consider the following pressure drops:

- 1 m of concentric pipe Ø 80/125 = 1 m of ducted pipe;
- 1 87° bend = 1.4 m of ducted pipe;

Consequently one must subtract the equivalent length of the part added to the 28 m available.

1-24

Rigid Ø 60 ducting (A) mm	SHAFT (B) mm	SHAFT (C) mm
66	106	126

Rigid Ø 80 ducting (A) mm	SHAFT (B) mm	SHAFT (C) mm
86	126	146

Flexible Ø 80 ducting (A) mm	SHAFT (B) mm	SHAFT (C) mm
90	130	150

Kit composition:

Ref.	Qty	Description
1	1	Door adaptor Ø 100 or Ø 125
2	1	Door gasket made of neoprene
3	4	Screws 4.2 x 9 AF
4	1	Hex headed screw M6 x 20
5	1	Flat nylon washer M6
6	2	Door hole closure metal-sheet plate plug
7	1	Plug gasket made of neoprene
8	1	Toothed washer M6
9	1	Nut M6
10	1 (kit 80/125)	Concentric gasket Ø 60-100
11	1 (kit 80/125)	Flanged adaptor Ø 80-125)
12	4 (kit 80/125)	Hex headed screws M4 x 16 slotted
-	1 (kit 80/125)	Bag of lubricating talc

Installation drawings key:

① Unique identification of the component in the kit

A Identification of the component not supplied in this kit

Supplied separately:

Ref.	Qty	Description
A	1	Ducting kit door

I-25

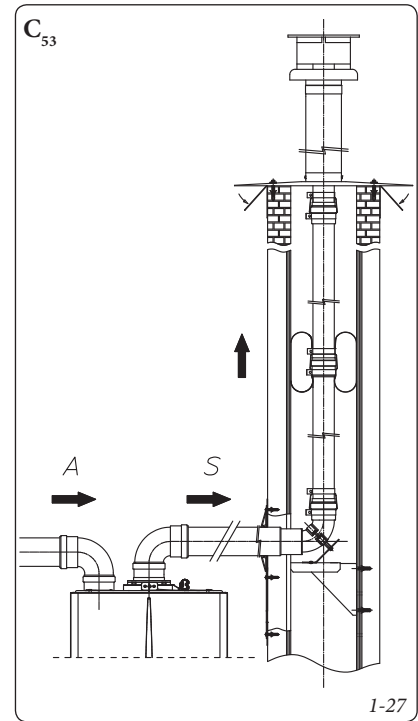
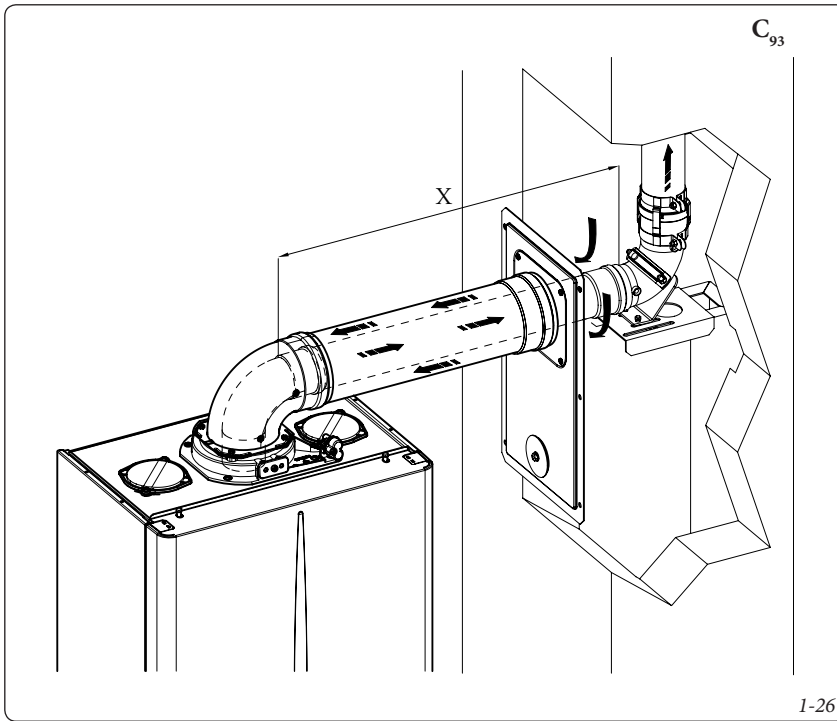

1.17 DUCTING OF FLUES OR TECHNICAL SLOTS.

Ducting is an operation through which, via the introduction of one or more relevant pipes, one achieves a system for the evacuation of the combustion products of a gas appliance, made up from the coupling of an existing or new ducting pipe with a chimney, flue or technical slot (also in new buildings) (Fig. 1-27). Ducting requires ducts declared to be suitable for the purpose by the manufacturer, following the installation and user instructions, provided by the manufacturer and the requirements of the standards in force.

Immergas ducting system. *The Ø 60 rigid and Ø 80 flexible "Green Range" ducting systems must only be used for domestic use and with Immergas condensing boilers.*

In any case, ducting operations must respect the provisions contained in the standard and in current technical regulations; in particular, the declaration of conformity must be compiled at the end of work and on commissioning of the ducted system. The instructions in the project or technical report must likewise be followed, in cases provided for by the standard and current technical regulations. The system or components of the system have a technical life complying with current standards, provided that:

- it is used in average atmospheric and environmental conditions, according to current regulations (absence of fumes, dusts or gases that can alter the normal thermophysical or chemical conditions; existence of temperatures coming within the standard range of daily variation, etc.).
- Installation and maintenance must be performed according to the indications supplied by the manufacturer and in compliance with the regulations in force.
 - The maximum length specified by the manufacturer must be respected; in this regard:
 - the max. possible length of the Ø 60 flexible ducting vertical section is equal to 22 m. This length is obtained considering the complete

Ø 80 exhaust terminal, 1m of Ø 80 pipe in exhaust, two 90° Ø 80 bends at boiler outlet.

- The max. possible length of the Ø 80 flexible ducting vertical section is equal to 30 m. This length is obtained considering the complete exhaust terminal, 1m of Ø 80 pipe in exhaust, two 90° Ø 80 bends at boiler outlet for connecting to the ducting system and two direction changes of the flexible hose inside the chimney/technical slot.
- The maximum possible length of the Ø 80 rigid ducting vertical section is equal to 30 m. This length is obtained considering the complete Ø 80 exhaust terminal, 1m of Ø 80 pipe in exhaust, two 90° Ø 80 bends on the boiler outlet.

1.18 CONFIGURATION TYPE B, OPEN CHAMBER AND FORCED DRAUGHT FOR INDOORS.

The appliance can be installed inside buildings in B₂₃ or B₅₃ mode; in this case, all technical rules and national and local regulations in force, must be complied with.

- type B open chamber boilers must not be installed in places where commercial, artisan or industrial activities take place, which use products that may develop volatile vapours or substances (e.g. acid vapours, glues, paints, solvents, combustibles, etc.), as well as dusts (e.g. dust deriving from the working of wood, coal fines, cement, etc.), which may be harmful for the components of the appliance and jeopardise operation.
- in B₂₃ and B₅₃ configuration the boilers must not be installed in bedrooms, bathrooms or bedsits, unless otherwise provided for by local regulations in force. They must neither be installed in rooms containing solid fuel heat generators nor in rooms communicating with said rooms.
- The installation of appliances in B₂₃ and B₅₃ configurations are only recommended in places that are not lived in and which are permanently ventilated.

The suitable kit referred to in paragraph 1.8 must be used for installation.

1.19 FLUE EXHAUST TO FLUE/CHIMNEY.

The flue exhaust does not necessarily have to be connected to a branched type traditional flue. The flue exhaust, for boiler clots installed in C configuration, can be connected to a special LAS type multiple flue. For B configurations, exhaust is only allowed into individual chimney or directly into the external atmosphere via a suitable terminal, unless otherwise provided for by local regulations in force. The multiple flues and the combined flues must also only be connected to type C appliances of the same type (condensing), having nominal heat inputs that do not differ by more than 30% less with respect to the maximum that can be attached and powered by the same fuel. The thermo-fluid dynamic features (flue flow rate, % of carbon dioxide, % humidity etc...) of the appliances attached to the same multiple flues or combined flues, must not differ by more than 10% with respect to the average boiler attached. Multiple and combined flues must be specially designed according to the calculation method and requirements of the technical standards in force, by a professionally qualified company. Chimney or flue sections for connection of the flue exhaust pipe must comply with requisites of technical standards in force.

1.20 FLUES, CHIMNEYS, CHIMNEY POTS AND TERMINALS.

The flues, chimneys and chimney pots for the evacuation of combustion products must be in compliance with applicable standards. Chimneys and roof-installed exhaust terminals must comply with the outlet height and with the distance from technical volumes set forth by the technical standards in force.

Positioning the wall flue exhaust terminals. The wall flue exhaust terminals must:

- be installed on external perimeter walls of the building;
- be positioned according to the minimum distances specified in current technical standards.

Combustion products exhaust of natural draught or fan assisted appliances in open-top closed environments. In spaces closed on all sides with open tops (ventilation pits, courtyards etc.), direct combustion product exhaust is allowed for natural draught or fan assisted gas appliances with a heat input range from 4 to 35 kW, provided the conditions as per the current technical standards are respected.

1.21 SYSTEM FILLING.

Once the boiler is connected, proceed with system filling via the filling cock (Fig. 1-31 and 1-3). Filling is performed at low speed and using the automatic vent functions to ensure release of air bubbles in the water via the boiler and heating system vents.

The boiler has a built-in automatic venting valve on the circulator. *Check if the cap is loose.* Open the radiator vent valves.

Close radiator vent valves when only water escapes from them.

Close the filling cock when the boiler pressure gauge indicates approx. 1.2 bar.

1.22 CONDENSATE TRAP FILLING.

On first lighting of the boiler, flue gas may come out the condensate drain; after a few minutes' operation check that this no longer occurs. This means that the drain trap is filled with condensate to the correct level preventing the passage of flue gas.

1.23 GAS SYSTEM START-UP.

To start up the system, refer to the technical standard in force. In particular, for new gas systems:

- open windows and doors;
- avoid presence of sparks or open flames;
- bleed all air from the pipelines;
- check that the internal system is properly sealed according to the specifications set forth by technical regulations in force.

1.24 BOILER START UP (IGNITION).

To commission the boiler (the operations listed below must only be performed by a qualified firm and without any unauthorised persons):

- check that the internal system is properly sealed according to the specifications set forth by technical regulations in force;
- make sure that the type of gas used corresponds to boiler settings;
- Check that there are external factors that may cause the formation of fuel pockets;
- switch the boiler on and check correct ignition;
- make sure that the gas flow rate and relevant pressure values comply with those given in the manual (Par. 3.18);
- ensure that the safety device intervenes in the event of gas supply failure and check the relative intervention time;
- check activation of the main switch located upstream from the boiler and in the boiler;
- check that the intake and/or exhaust terminals (if fitted) are not blocked.

The boiler must not be started up even if only one of the checks should be negative.

1.25 CIRCULATION PUMP.

The boiler is supplied with circulator fitted with speed regulator. These settings are suitable for most systems.

In fact, the pump is equipped with electronic control to set advanced functions. For proper operation one must select the most suitable type of operation for the system and select a speed in the available range, with a focus on energy savings.

By-pass Regulation (part. 31 Fig. 1-31). The boiler leaves the factory with all bypasses open. If necessary, the by-pass can be regulated to system requirements from minimum (by-pass closed) to maximum (by-pass open). Adjust using a flat head screwdriver, turn clockwise and open the by-pass, anticlockwise it is closed.

Display of operation status. During normal operation the status LED (2) is on green, the four yellow LEDs (3) indicate circulator absorption according to the following table:

Circulating pump LED	Absorption
G Y Y Y Y On On Off Off Off	0 ÷ 25 %
G Y Y Y Y On On On Off Off	25 ÷ 50 %
G Y Y Y Y On On On On Off	50 ÷ 75 %
G Y Y Y Y On On On On On	75 ÷ 100 %

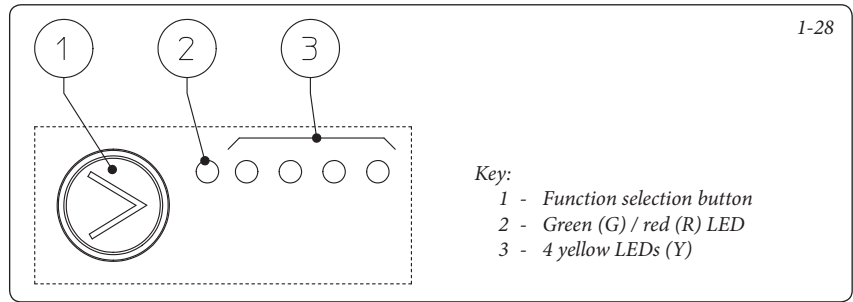

Selection of operating mode. To see the current operation mode it is sufficient to press button (1) once.

To change operation mode press the button for between 2 to 10 seconds until the current configuration flashing, each time the button is pressed all possible functions are scrolled cyclically. After a few seconds without doing any operation the circulator memorises the selected mode and goes back to operation display.

Attention: The circulator has various built-in operation modes, however the constant curve operation mode must be selected according to the following table.

Circulating pump LED	Description
G Y Y Y Y On On On Off Off	Do not use
G Y Y Y Y On On On On Off	Constant curve speed 2
G Y Y Y Y On On On On On	Constant curve speed 3 (default for Victrix EXA 28 1 ErP)
G Y Y Y Y On On On Off On	Constant curve speed 4 (default for Victrix EXA 32 1 ErP)

Constant curve: the circulator operates maintaining constant speed.

Selection button lock. The button has a feature that locks its operation to prevent accidental modifications, to lock the control panel it is necessary to press button (1) longer than 10 seconds (during which the current configuration flashes), the active lock is signalled by all LEDs of the control panel flashing. To unlock the button press again longer than 10 seconds.

Real time diagnostics: in the event of malfunction the LEDs provide information on the circulator operation status, see table (Fig. 1-29):

I-29

Circulating pump LED (first red LED)	Description	Diagnostics	Remedy
R Y Y Y Y On Off Off Off On	Circulator pump blocked	The circulator pump cannot restart automatically due to an anomaly	Wait for the circulator to make automatic release attempts or manually release the motor shaft acting on the screw in the centre of the head. If the anomaly persists replace the circulator.
R Y Y Y Y On Off Off On Off	Abnormal situation (the circulator continues operating). low power supply voltage	Voltage off range	Check power supply.
R Y Y Y Y On Off On Off Off	Electrical fault (Circulator pump blocked)	The circulator is locked due to power supply too low or serious malfunction	Check the power supply, if the anomaly persists replace the circulator.

Total head available to the system.

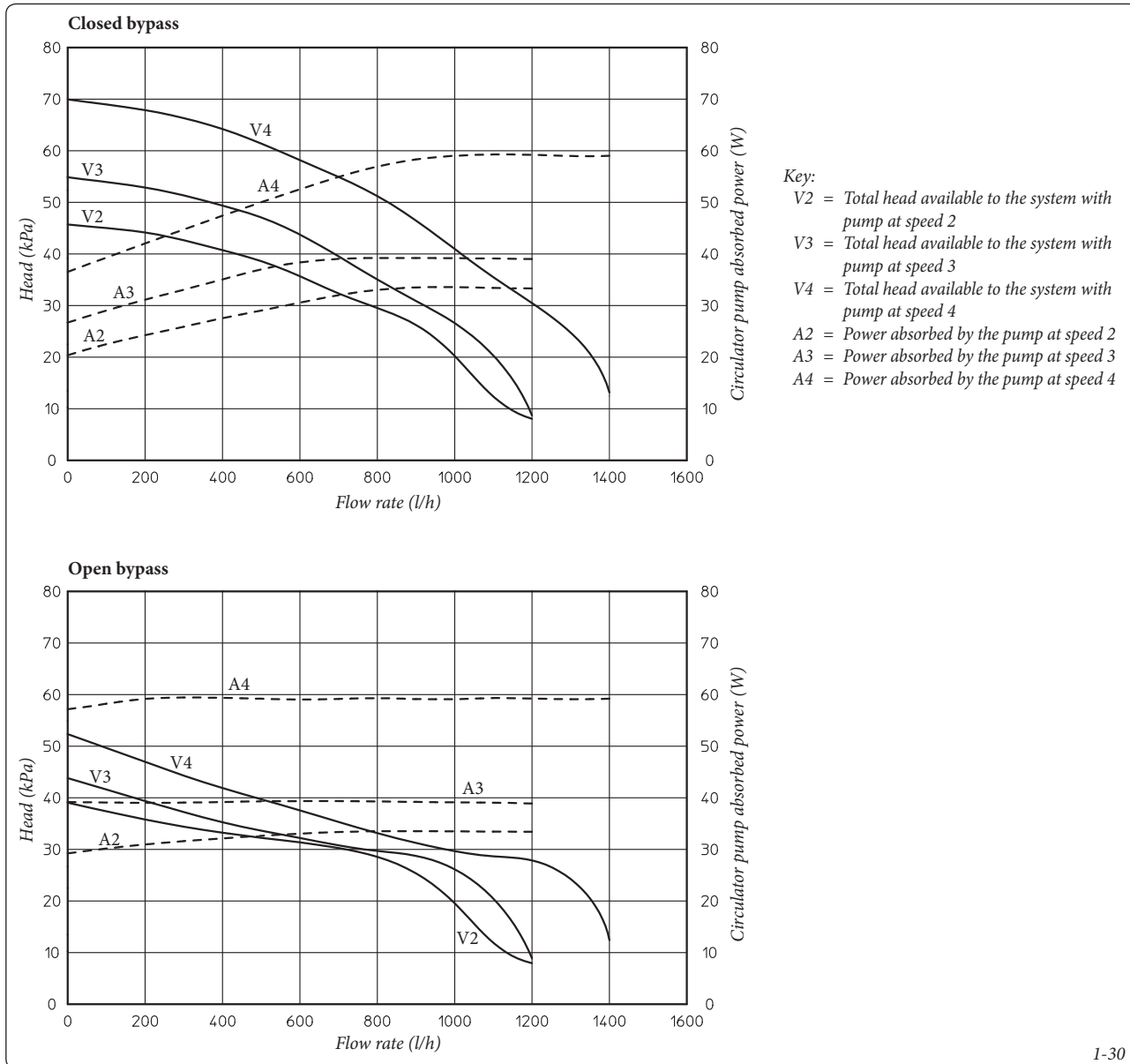

I-30

1.26 KITS AVAILABLE ON REQUEST.

- System shut-off valve kits with or without inspection filter (on request). The boiler is designed for installation of system interception cocks to be placed on flow and return pipes of the connection assembly. This kit is very useful for maintenance because it allows to empty just the boiler without having to empty the entire system. Moreover, the version with filter preserves the functioning characteristics of the boiler thanks to its inspectionable filter.
- System zone control unit kit (on request). If the heating system is to be divided into several zones (**max. three**), in order to interlock them with separate adjustments and to keep water flow rate high for each zone, Immergas supplies zone system kits by request.

- Polyphosphate dispenser kit (on request). The polyphosphate dispenser reduces the formation of lime-scale and preserves the original heat exchange and domestic hot water production conditions. The boiler is prepared for application of the polyphosphate dispenser kit.
- Relay board (on request). The boiler is prepared for the installation of a relay card that allows to increase the features of the appliance and therefore functioning possibilities.
- Cycloidal filter kit (on request). The magnetic cycloidal filter is able to detect the ferrous residues present in the system's water. Thanks to the two cocks in the kit, it facilitates maintenance by cleaning the filter without having to empty the circuit.

- Cover kit (on request). If installed outdoors in a partially protected place with direct air intake, it is compulsory to mount the appropriate top protection cover for the correct functioning of the boiler and to protect it from adverse weather conditions.

The above-mentioned kits are supplied complete with instructions for assembly and use.

1.27 BOILER COMPONENTS.

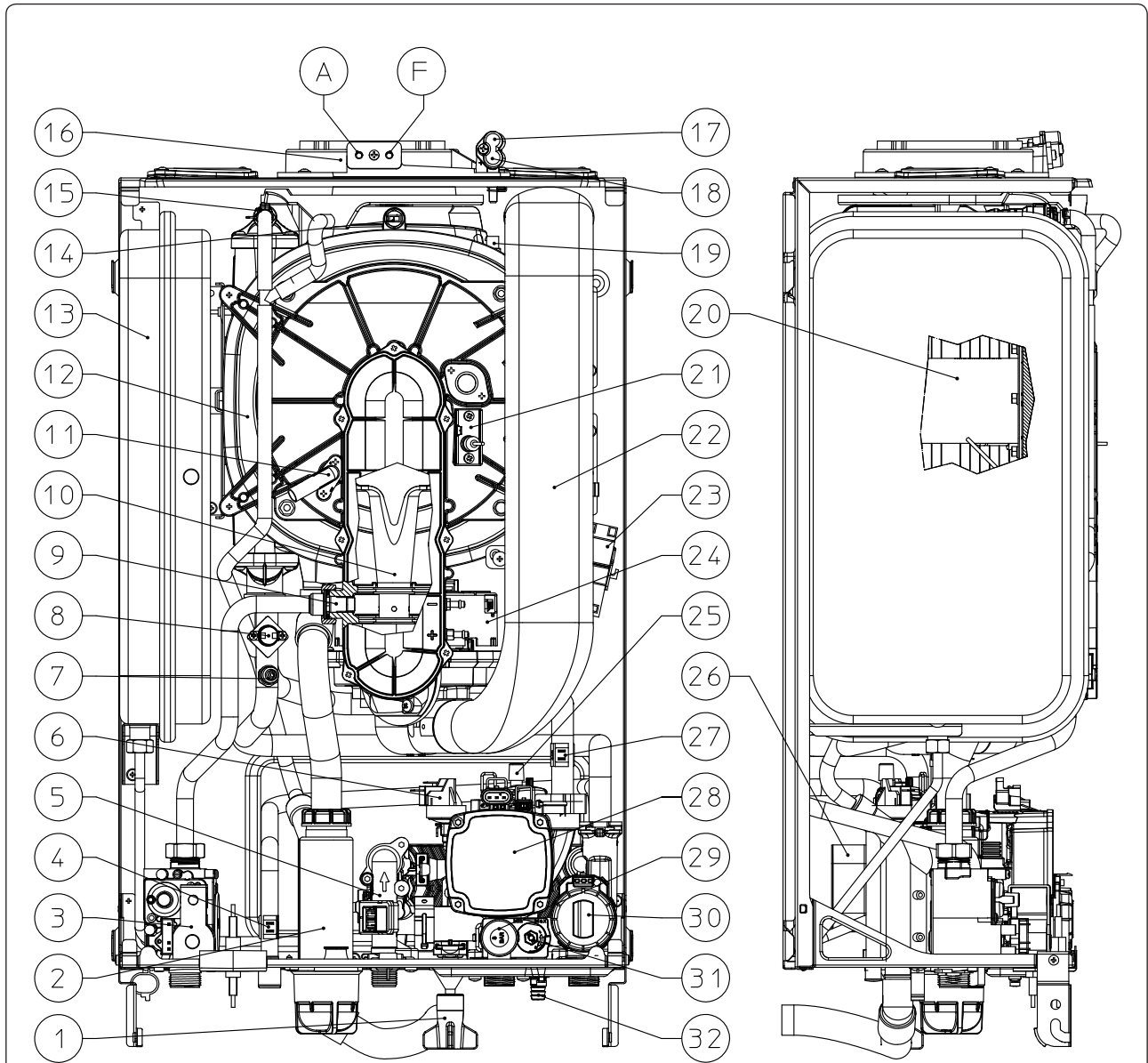

Key:

- | | |
|---|---|
| 1 - System filling cock | 17 - Negative signal pressure point |
| 2 - Condensate drain trap | 18 - Positive signal pressure point |
| 3 - Gas valve | 19 - Heat exchanger safety thermal fuse |
| 4 - Domestic hot water probe | 20 - Burner |
| 5 - Domestic hot water flow switch | 21 - Ignition electrode |
| 6 - System pressure switch | 22 - Air intake pipe |
| 7 - Delivery probe | 23 - Igniter |
| 8 - Safety thermostat | 24 - Fan |
| 9 - Gas nozzle | 25 - Vent valve |
| 10 - Venturi | 26 - DHW heat exchanger |
| 11 - Detection electrode | 27 - Return probe |
| 12 - Condensation module | 28 - Boiler circulator pump |
| 13 - System expansion vessel | 29 - 3 bar safety valve |
| 14 - Flue probe | 30 - 3-way valve (motorised) |
| 15 - Manual air vent valve | 31 - By-pass |
| 16 - Sample points (air A) - (flue gas F) | 32 - System draining valve |

INSTALLER

USER

MAINTENANCE TECHNICIAN

2 USE AND MAINTENANCE INSTRUCTIONS

2.1 CLEANING AND MAINTENANCE.

Attention: to preserve the boiler's integrity and keep the safety features, performance and reliability which distinguish it unchanged over time, maintenance operations must be carried out on a yearly basis in compliance with that stated in the "annual check and maintenance of the appliance" section, in compliance with national, regional, or local standards in force.

2.2 GENERAL WARNINGS.

Never expose the wall-mounted boiler to direct vapours from cooking hobs.

Use of the boiler by unskilled persons or children is prohibited.

For safety purposes, check that the air intake/ flue exhaust terminals (if fitted) are not blocked. If temporary shutdown of the boiler is required, proceed as follows:

- drain the water system if antifreeze is not used;
- shut-off all electrical, water and gas supplies.

In the event of work or maintenance on structures located in the vicinity of ducting or devices for flue extraction and relative accessories, switch off the appliance and on completion of operations

ensure that an authorised company checks the efficiency of the ducting or other devices.

Never clean the appliance or connected parts with easily flammable substances.

Never leave containers or flammable substances in the same environment as the appliance.

• **Attention:** the use of components involving use of electrical power requires some fundamental rules to be observed, such as:

- do not touch the appliance with wet or moist parts of the body; do not touch when bare-foot;
- never pull electrical cables nor leave the appliance exposed to weathering (rain, sunlight, etc.);
- the appliance power cable must not be replaced by the user;
- if the cable is damaged, switch off the appliance and solely contact an authorised company to replace it;
- if the appliance is not to be used for a certain period, disconnect the main power switch.

N.B.: the temperatures indicated by the display have a tolerance of +/- 3°C due to environmental conditions that cannot be attributed to the boiler.

At the end of its service life the appliance must not be disposed of like normal household waste nor abandoned in the environment, but must be removed by a professionally authorised company. Contact the manufacturer for disposal instructions.

2.3 CONTROL PANEL.

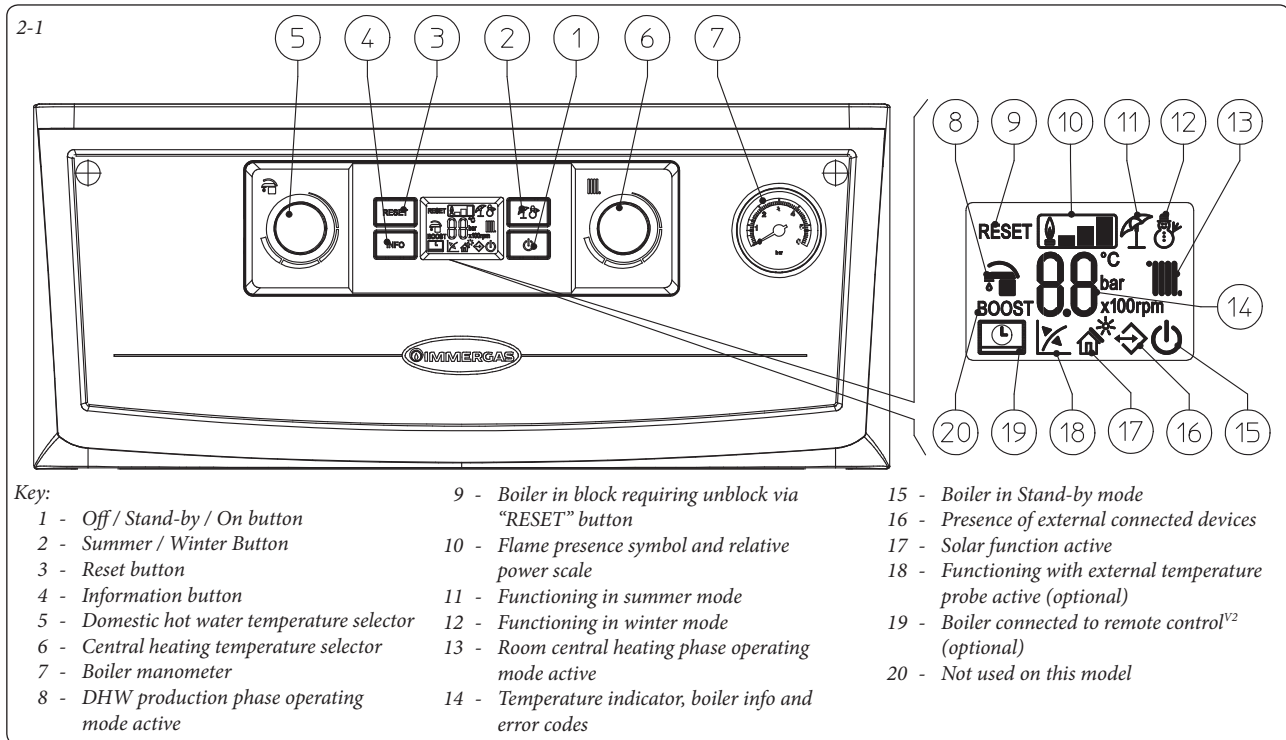

2.4 USING THE BOILER.

Before ignition make sure the heating system is filled with water and that the manometer (7) indicates a pressure of 1 ÷ 1.2 bar.

- Open the gas cock upstream from the boiler.
- Press the button (1) until the display switches on. The boiler now returns to the state prior to switch-off.
- If the boiler is in stand-by, press the button (1) again to activate it. If this is not the case, go to the next point.

- Then press the button (2) in sequence and set the boiler in the summer (☀) or winter (❄) position.

- **Summer (☀):** in this mode the boiler only works to produce DHW; the temperature is set via the selector (5) and the relative temperature is shown on the display via the indicator (14).
- **Winter (❄):** in this mode the boiler works both for producing domestic hot water and for central heating. The temperature of the DHW is



always regulated via the selector (5), the heating temperature is regulated via selector (6) and the relative temperature is shown on the display via the indicator (14).

From this moment the boiler functions automatically. With no demand for heat (central heating or domestic hot water production) the boiler goes to "standby" function, equivalent to the boiler being powered without presence of flame. Each time the burner ignites, the relative flame present symbol is displayed (10) with relative output scale.

• **Operation with Comando Amico Remoto^{v2} (CAR^{v2}) (Optional).** If the CAR^{v2} is connected, the () symbol will appear on the display. The boiler regulation parameters can be set via the CAR^{v2} control panel and the reset button (3) remains active on the boiler control panel, along with the switch-off button (1) (“off” mode only) and the display where the functioning state is shown.

Caution: if the boiler is switched “off” the CAR^{v2} will display the connection error symbol “ERR>CM”, the CAR^{v2} is however powered constantly so as not to lose the stored programs.

• **Solar operating mode** (). This function is activated automatically if the boiler detects a probe on the DHW inlet (optional) or if the “Solar ignition delay” parameter is more than 0 seconds.

During a withdrawal, if the outlet water is hot enough, the boiler does not switch on, the DHW withdrawal symbol () appears on the display along with the flashing solar function symbol ().

When the water supplied by the solar system is at a temperature lower than that at which the boiler is set, the boiler switches on. At this point, the solar function symbol will stay on without flashing.

• **Operation with optional external probe** (). In the case of a system with optional external probe, the boiler flow temperature for room central heating is managed by the

external probe depending on the external temperature measured (Par. 1.8). The flow temperature can be modified by selecting the functioning curve via the selector switch (6) (or on the CAR^{v2} control panel, if connected to the boiler) selecting a value from “0 to 9”.

With external probe present, the relative symbol (18) will appear on the display. In the central heating phase, if the temperature of the water contained in the system is sufficient to heat the radiators, the boiler can only function with the activation of the pump.

• **“Stand-by” mode.** Press button (1) repeatedly until the symbol () appears. From now on the boiler remains inactive and the antifreeze function, pump anti-block function and 3-way and signalling of any anomalies is guaranteed.

N.B.: in these conditions the boiler is still powered.

• **“Off” mode.** By holding the button (1) down for 8 seconds, the display switches-off and the boiler is off completely. The safety functions are not guaranteed in this mode.

IMPORTANT NOTE: in these conditions the boiler is considered still live even if there are no functions active.

• **“Automatic vent” mode.** Every time the boiler is electrically powered, the system automatic vent function is activated (lasting 8 minutes). This function is displayed via a countdown signalled by the indicator (14). During this period the DHW and CH functions are not active.

The “automatic vent” can be annulled by pressing the “reset” button (4).

• **Display operation.** The display lights up during the use of the control panel, after 15 seconds inactivity, the brightness drops until just the active symbols are displayed. The lighting mode can be varied via parameter T3 in the P.C.B. customisation menu.

2.5 TROUBLESHOOTING.

The Victrix EXA 28 1 ErP - 32 1 ErP boiler reports any anomalies using a code shown on the boiler display (14), listed in the table below: On the remote control, the error code will be displayed by means of the same numeric code represented according to the following example (e.g. CAR^{v2} = Exx).

Error Code	Anomaly signalled	Cause	Boiler status / Solution
01	No ignition block	In the event of request of room central heating or domestic hot water production, the boiler does not switch on within the preset time. Upon appliance commissioning or after extended downtime, it may be necessary to eliminate the block.	Press the Reset button (1).
02	Safety thermostat block (over-temperature)	During normal operation, if a fault causes excessive overheating internally, the boiler goes into overheating block.	Press the Reset button (1).
03	Flue safety thermostat block	During normal operation, if a fault causes excessive flue gas overheating, the boiler blocks.	Press the Reset button (1).
04	Contacts resistance block	The P.C.B. detects an anomaly on the gas valve supply. Check the connection. (the anomaly is detected and displayed only in the event of a request).	Press the Reset button (1).
05	Flow probe anomaly	The board detects an anomaly on the flow NTC probe.	The boiler does not start (1).
06	Domestic hot water probe anomaly	The board detects an anomaly on the domestic hot water NTC probe.	The boiler continues to produce domestic hot water but not with optimal performance. The antifreeze function is also disabled (1).
08	Maximum N° of reset	Number of allowed resets that have already performed.	Attention: the anomaly can be reset 5 times consecutively, after which the function is inhibited for at least one hour. One attempt is gained every hour for a maximum of 5 attempts. By switching the appliance on and off the 5 attempts are re-acquired.
10	Insufficient system pressure	Water pressure inside the central heating circuit that is sufficient to guarantee the correct operation of the boiler is not detected.	Check on the boiler pressure gauge (1) that the system pressure is between 1÷1.2 bar and restore the correct pressure if necessary.
15	Configuration error	If the board detects an anomaly or incongruity on the electric wiring, the boiler will not start.	If normal conditions are restored the boiler restarts without having to be reset. Check that the boiler is configured correctly (1).
16	Fan anomaly	This occurs if the fan has a mechanical or electrical fault.	Press the Reset button (1).
20	Parasite flame block	This occurs in the event of a leak on the detection circuit or anomaly in the flame control unit.	Press the Reset button (1).

(1) If the shutdown or fault persists, contact an authorised company (e.g. Authorised Technical After-Sales Service).

Error Code	Anomaly signalled	Cause	Boiler status / Solution
23	Return probe anomaly	The board detects an anomaly on the return NTC probe.	The boiler does not start (1).
24	Push button control panel anomaly	The board detects an anomaly on the pushbutton panel.	If normal conditions are restored the boiler restarts without having to be reset (1).
25	Block due to flue gas temperature gradient intervention	If the board detects a rapid increase in flue gas temperature probably due to a blocked circulating pump or lack of water in the heat exchanger, the boiler shuts down due to the flue gas temperature gradient trip.	Press the Reset button (1).
27	Insufficient circulation	This occurs if there is overheating in the boiler due to insufficient water circulating in the primary circuit; the causes can be: - low system circulation; check that no shut-off devices are closed on the heating circuit and that the system is free of air (deaerated); - pump blocked; free the pump.	Press the Reset button (1).
29	Flue probe anomaly	The board detects an anomaly on the flue gas probe.	The boiler does not start (1).
31	Loss of remote control communication	This occurs if an incompatible remote control is connected, or if communication between the boiler and the remote control is lost.	Disconnect and reconnect the power to the boiler. If the Remote Control is still not detected on re-starting, the boiler will switch to local operating mode, i.e. using the controls on the control panel. In this case the "Central Heating" function cannot be activated. (1).
36	IMG Bus communication loss	Communication between the various components is interrupted due to an anomaly on the boiler control unit, on the zone control unit or on the IMG Bus.	The boiler does not satisfy the room heating requests (1).
37	Low power supply voltage	This occurs when the power supply voltage is lower than the allowed limits for the correct boiler operation.	If normal conditions are restored the boiler restarts without having to be reset (1).
38	Loss of flame signal	This occurs when the boiler is ignited correctly and the burner flame goes out unexpectedly; a new ignition attempt is performed and if normal conditions are restored, the boiler does not have to be reset (this anomaly can only be checked in the list of errors present in the "Information" menu).	If normal conditions are restored the boiler restarts without having to be reset (1).
43	Block due to loss of continuous flame signal	This occurs if the "Flame signal loss" error occurs many times in a row within a preset period (38).	Press the Reset button, before restarting, the boiler will run a post-ventilation cycle. (1).
44	Block for exceeding the maximum accumulated time, close gas valve opening	This occurs if the gas valve remains open for longer than required for normal operation, without the boiler switching on.	Press the Reset button (1).
45	ΔT high	If the board detects a sudden and unexpected rise in ΔT between the system flow probe and return probe, the boiler limits the burner output to prevent damaging the condensing module; when the correct ΔT has been restored, the boiler returns to normal operation.	Make sure there is water circulating in the boiler, that the pump is configured according to system requirements and that the return probe works properly (1).
46	Low temperature safety thermostat (optional)	During normal operation, if an anomaly causes excessive overheating of the flow temperature in low temperature conditions, the boiler blocks.	In this case, after suitable cooling, it is possible to reset the thermostat (see relative instructions sheet) (1).
47	Burner power limitation	Should flue high temperature be detected, the boiler reduces power supplied so as not to damage it.	(1).
49	High temperature block on return probe	This occurs when the heat exchanger return circuit reaches a temperature that is too high.	Make sure that water circulates properly in the boiler and that the three-way valve works properly. Press the Reset button (C) to eliminate it (1).

(1) If the shutdown or fault persists, contact an authorised company (e.g. Authorised Technical After-Sales Service).

2.6 INFORMATION MENU.

By pressing the "Info" button (4), the "Information menu" is activated, which allows to display some boiler functioning parameters.

Press the "Info" button (4) to scroll the various parameters.

To exit the menu, press the "Info" button (4) up

to the end of the list, or by pressing the "Reset" button (3) or by waiting for 15 minutes.

With the menu active, the indicator (14) will alternately show the indication of the parameter via the letter "d" plus the number of the parameter that is being displayed and the value of the parameter itself.

Id Parameter	Description
d1	Displays the flame signal (uA x 10 approximate)
d2	Displays the primary exchanger output instant heating flow temperature
d3	Displays the instant output temperature from the DHW exchanger
d4	Displays the values set for central heating set
d5	Displays the values set for DHW set
d6	Displays the external temperature (if external probe present) If the temperature is below zero, the value is displayed flashing
d7	Display the temperature of the inlet DHW (with DHW inlet probe present)
d8	Return probe temperature
d9	Displays the list of the last five anomalies (to scroll the list, turn the CH temperature selector (6))

2.7 BOILER SHUTDOWN

For complete boiler switch-off, press the "off" button, disconnect the onnipolar switch outside of the boiler and close the gas cock upstream from the appliance. Never leave the boiler switched on if left unused for prolonged periods.

2.8 RESTORING CENTRAL HEATING SYSTEM PRESSURE.

Periodically check the system water pressure. The boiler pressure gauge should read a pressure between 1 and 1.2 bar.

If pressure falls below 1 bar (with the circuit cold), restore normal pressure via the cock located at the bottom of the boiler (Fig. 1-3).

N.B.: close the cock after the operation.

If pressure values reach around 3 bar the safety valve may be activated.

In this case, remove water from an air vent valve of a radiator until 1 bar is reached or ask for assistance from an authorised company.

If frequent pressure drops should occur, ask an authorised company for assistance to eliminate the possible system leakage.

2.9 SYSTEM DRAINING.

To drain the boiler, use the special system draining valve (Fig. 1-3).

Before draining, ensure that the system filling cock is closed.

2.10 ANTI-FREEZE PROTECTION.

The boiler has an anti-freeze function that switches on automatically when the temperature falls below 4°C (standard protection to minimum temperature of -5°C). All information relative to the anti-freeze protection is stated in Par. 1.3. In order to guarantee the integrity of the appliance and the domestic hot water heating system in zones where the temperature falls below zero, we recommend the central heating system is protected using anti-freeze liquid and installation of the Immergas Anti-freeze Kit in the boiler. In the case of prolonged inactivity (second case), we also recommend that:

- disconnect the electric power supply;
- the central heating circuit and boiler domestic hot water circuit must be drained. In systems that are drained frequently, filling must be carried out with suitably treated water to eliminate hardness that can cause lime-scale.

2.11 CASE CLEANING.

Use damp cloths and neutral detergent to clean the boiler casing. Never use abrasive or powder detergents.

2.12 DECOMMISSIONING.

In the event of permanent shutdown of the boiler, contact an authorised company for the suitable procedures and also ensure the electrical, water and fuel supply lines are shut off and disconnected.

3 BOILER COMMISSIONING (INITIAL CHECK)

To commission the boiler:

- make sure that the type of gas used corresponds to boiler settings;
- check connection to a 230V-50Hz power mains, correct L-N polarity and the earthing connection;
- make sure the central heating system is filled with water and that the pressure gauge indicates a pressure of 1-1.2 bar.
- switch the boiler on and check correct ignition;
- check the Δp gas values in domestic hot water

- and central heating modes;
- check activation of the safety device in the event of no gas, as well as the relative activation time;
- check the intervention of the main switch located upstream of the boiler and in the boiler;
- check that the intake and/or exhaust terminals are not blocked;
- ensure activation of all adjustment devices;
- seal the gas flow rate regulation devices (if settings are modified);
- check the production of domestic hot water;
- check sealing efficiency of water circuits;

- check ventilation and/or aeration of the installation room where provided.

If even only a single safety check offers a negative result, do not commission the system.

3.1 PLUMBING DIAGRAM.

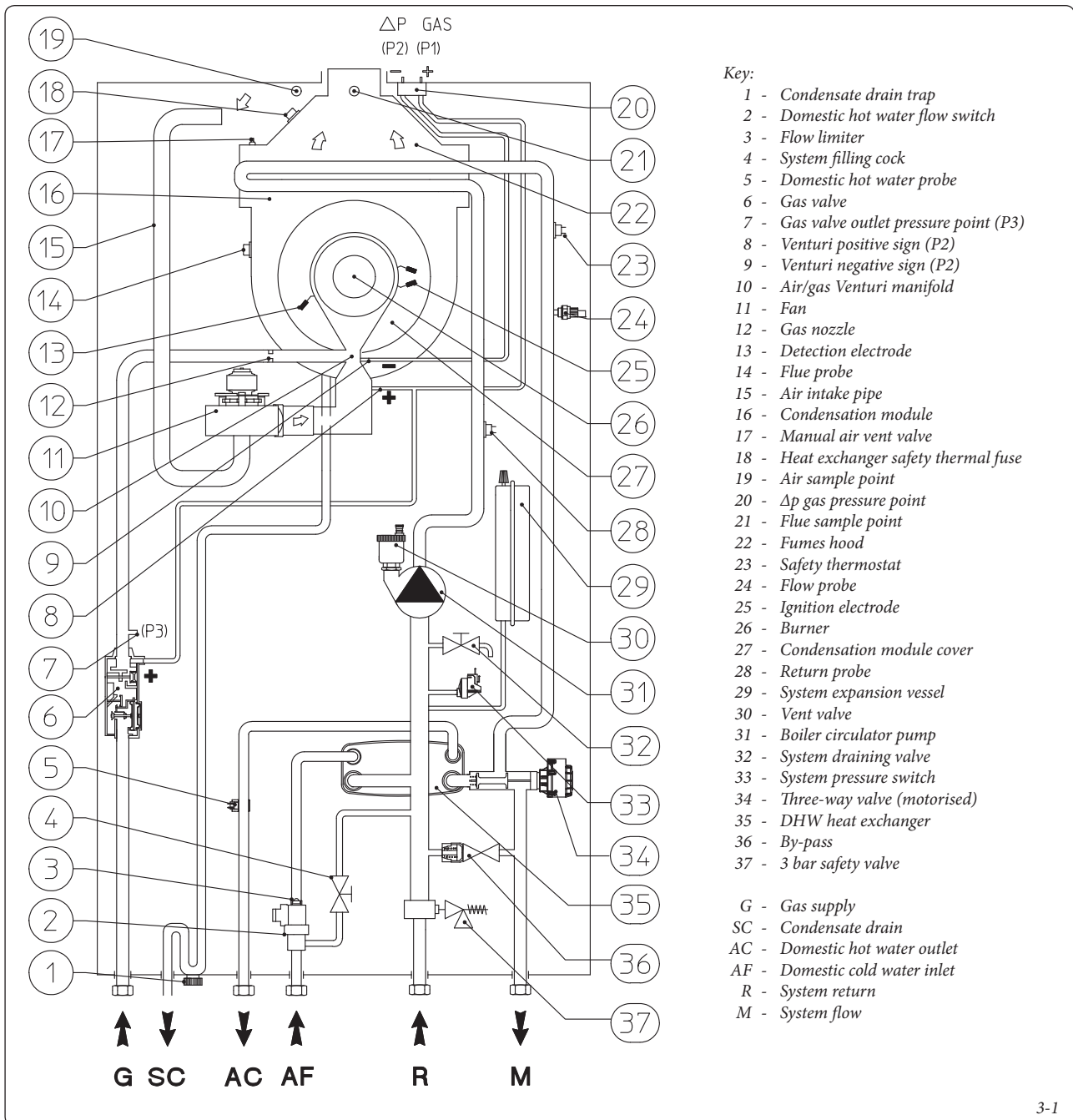

3.2 WIRING DIAGRAM.

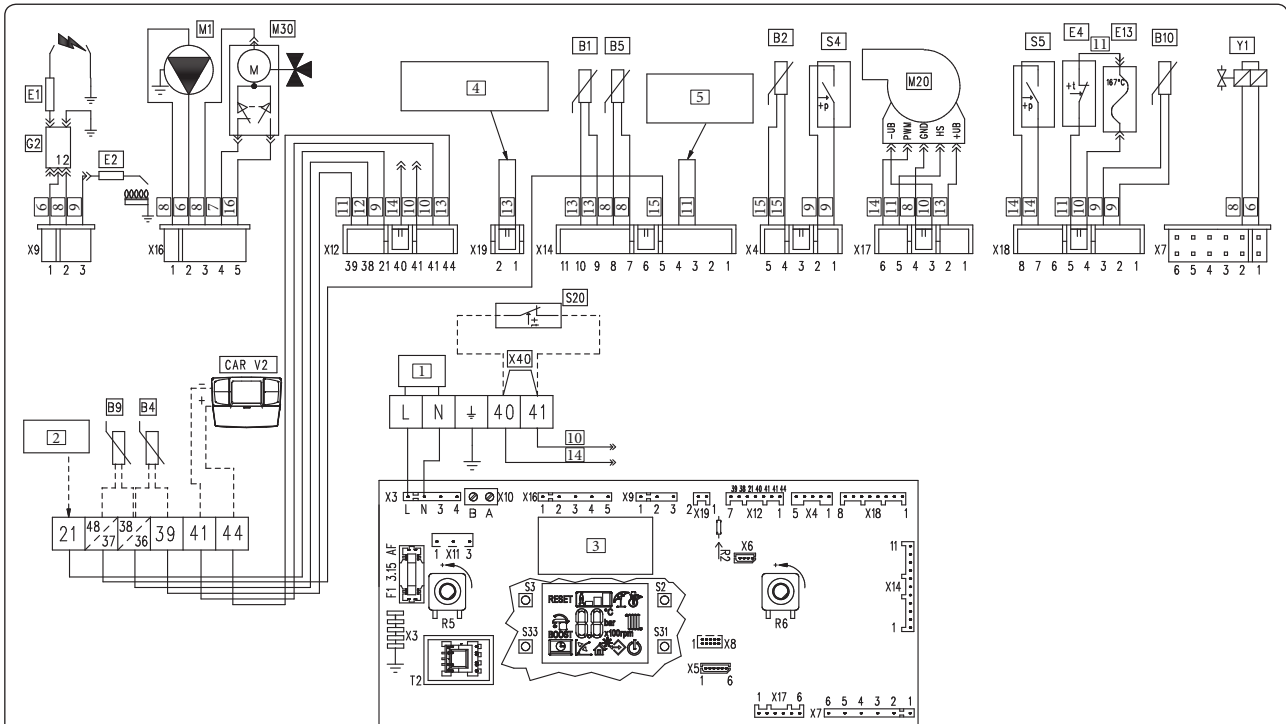

Key:

- | | | |
|--|---|---|
| B1 - Flow probe | M30 - Three-way valve | 4 - Safety thermostat (low temperature) connection jumper |
| B2 - Domestic hot water probe | R5 - Domestic hot water temperature trimmer | 5 - Return probe function configuration jumper |
| B4 - External probe (optional) | R6 - Central heating temperature trimmer | 6 - Brown |
| B5 - Return probe | S2 - Operation selector | 7 - Black (DHW) |
| B9 - Domestic hot water inlet probe (optional) | S3 - Block reset button | 8 - Blue |
| B10 - Flue probe | S4 - Domestic hot water flow switch | 9 - Grey |
| CAR ^{V2} - Comando Amico Remoto remote control ^{V2} (optional) | S5 - System pressure switch | 10 - Black |
| E1 - Ignition electrodes | S20 - Room thermostat (optional) | 11 - White |
| E2 - Detection electrode | S31 - On/Stand-by/Off Button | 12 - Pink |
| E4 - Safety thermostat | S33 - Info button | 13 - Red |
| E13 - Heat exchanger safety thermofuse | T2 - Boiler board transformer | 14 - Orange |
| G2 - Igniter | X40 - Room thermostat jumper | 15 - Green |
| M1 - Boiler circulator pump | Y1 - Gas valve | 16 - Brown (C.H.) |
| M20 - Fan | | |
- 1 - 230 Vac 50 Hz power supply
 2 - Status signal
 3 - N.B.: the user interface is on the welding side of the boiler board

3-2

Comando Amico Remoto remote control^{V2}: the boiler is set-up for the application of the Comando Amico Remoto remote control ^{V2} (CAR^{V2}), which must be connected to clamps 41 and 44 of the terminal board, by observing polarity and eliminating jumper X40.

Room ON-OFF thermostat: the boiler is set-up for the application of the Room Thermostat (S20), which must be connected to clamps 40 and 41 of the terminal board and by eliminating jumper X40.

The connector X5 is used for the connection to the relay board.

Connector X6 is for connection to a personal computer.

The connector X8 is used for software updating operations.

3.3 TROUBLESHOOTING.

N.B.: maintenance operations must be carried out by an authorised company (e.g. Authorised After-Sales Technical Assistance Service).

- Smell of gas. Caused by leakage from gas circuit pipelines. Check sealing efficiency of gas intake circuit.

- Repeated ignition blocks. It can be caused by no gas, check the presence of pressure in the network and that the gas adduction cock is open. Incorrect adjustment of the gas cock, check the correct calibration of the gas valve.

- Irregular combustion or noisiness. It may be caused by: a dirty burner, incorrect combustion parameters, intake-exhaust terminal not correctly installed. Clean the above components and ensure correct installation of the terminal, check correct setting of the gas valve (Off-Set setting) and correct percentage of CO₂ in flue gas.

- Frequent interventions of the overheating safety thermostat. It can depend on the lack of water in the boiler, little water circulation in the system or blocked pump. Check on the manometer that the system pressure is within established limits. Check that the radiator valves are not closed and also the functionality of the pump.

- Drain trap clogged. This may be caused by dirt or combustion products deposited inside. Check, by means of the condensate drain cap, that there are no residues of material blocking the flow of condensate.

- Heat exchanger clogged. This may be caused by the drain trap being blocked. Check, by means of the condensate drain cap, that there are no residues of material blocking the flow of condensate.

- Noise due to air in the system. Check opening of the special air vent valve cap (Fig. 1-31). Make sure the system pressure and expansion vessel pre-charge values are within the set limits; The factory-set pressure values of the expansion vessel must be 1.0 bar, the value of system pressure must be between 1 and 1.2 bar.

- Noise due to air inside the condensation module. Use the manual air vent valve (Fig. 1-31) to eliminate any air present in the condensation module. When the operation has been performed, close the manual vent valve.

INSTALLER

USER

MAINTENANCE TECHNICIAN

3.4 CONVERTING THE BOILER TO OTHER TYPES OF GAS.

If the boiler has to be converted to a different gas type to that specified on the data nameplate, request the relative conversion kit for quick and easy conversion.

The gas conversion operation must be carried out by an authorised company (e.g. Authorised After-Sales Technical Assistance Service).

To convert to another type of gas the following operations are required:

- disconnect the appliance;
- replace the nozzle located between the gas pipe and gas/air mixing sleeve (Part. 9 Fig. 1-31);
- re-power the appliance;
- calibrate the number of fan revolutions (parag. 3.5);
- adjust the correct air/gas ratio (parag. 3.6);
- seal the gas flow rate regulation devices (if settings are modified);
- after completing the conversion, apply the sticker, contained in the conversion kit, near the data nameplate. Using an indelible marker pen, delete the data relative to the old type of gas.

These adjustments must be made with reference to the type of gas used, following that given in the table (Par. 3.18).

3.5 CALIBRATION OF NUMBER OF FAN REVS.

Attention: verification and calibration is necessary, in the case of transformation to other types of gas, in the extraordinary maintenance phase with replacement of the PCB air/gas circuit components or in the case of installations with flue extraction systems, with horizontal concentric pipe measuring more than 1 metre.

The boiler heat output is correlated to the length of the air intake and flue exhaust pipes. This decreases with the increase of pipe length. The boiler leaves the factory adjusted for minimum pipe length (1m). It is therefore necessary, especially in the case of maximum pipe extension, to check the Δp gas values after at least 5 minutes of the burner operating at nominal heat output, when the temperatures of the intake air and exhaust flue gas have stabilised. Adjust the nominal and minimum heat output in the domestic hot water and central heating modes according to the values in the table (Par. 3.18) using the differential manometers connected to the Δp gas pressure points (17 and 18 Fig. 1-31).

Enter the configurations menu and regulate the following parameters (Par. 3.8):

- minimum DHW power output;
- maximum DHW power output;
- minimum central heating output;
- maximum central heating output;
- Ignition power.

3.6 ADJUSTMENT OF THE AIR-GAS RATIO.

Attention: the CO₂ verification operations must be carried out with the casing mounted, while the gas valve calibration operations must be carried out with the casing open and disconnecting the boiler from the power supply.

To have an exact value of CO₂ in the flue gases, the technician must insert the sampling probe to the bottom of the sample point, then check that the CO₂ value is that specified in the following tables (using maximum tolerance of $\pm 2\%$), otherwise change the value described as follows:

- Calibration of the minimum CO₂ (minimum central heating power).

Enter the chimney sweep phase without withdrawing domestic hot water and take the selector switches to minimum (turn them in an anti-clockwise direction until "0" is seen on the display).

Adjust the screw (3 Fig. 3-4) (Off-Set adjuster). To increase the CO₂ value, turn the adjustment screw (3) in a clockwise direction and vice versa to decrease it.

- Calibration of the maximum CO₂ (nominal central heating power).

On completion of the adjustment of the minimum CO₂ keeping the chimney sweep function active, take the heating selector switch to maximum (turn it in a clockwise direction until "99" is seen on the display).

Adjust the screw (3 Fig. 3-4) (gas flow rate regulator). To increase the CO₂ value, turn the adjustment screw (12) in an anti-clockwise direction and vice versa to decrease it.

At every adjustment variation on the screw 12 it is necessary to wait for the boiler to stabilise itself at the value set (about 30 sec.).

Victrix EXA 28 1 ErP		
	CO ₂ at nominal output (99 %)	CO ₂ at minimum output (0 %)
G 20	9.40	8.60
G 30	12.00	11.40
G 31	10.80	10.40

Victrix EXA 32 1 ErP		
	CO ₂ at nominal output (99 %)	CO ₂ at minimum output (0 %)
G 20	9.60	8.70
G 30	12.30	11.10
G 31	10.50	9.70

3-3

Gas Valve 848

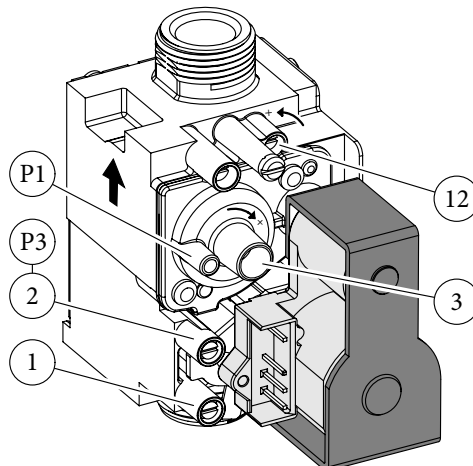

Key:

- 1 - Gas valve inlet pressure point
- 2 - Gas valve outlet pressure point
- 3 - Off/Set adjustment screw
- 12 - Outlet gas flow rate regulator

3-4

3.7 CHECKS FOLLOWING CONVERSION TO ANOTHER TYPE OF GAS.

After making sure that conversion was carried out with a nozzle of suitable diameter for the type of gas used and the settings are made at the correct pressure, check that the burner flame is not too high or low and is stable (does not detach from burner);

Note: all boiler adjustment operations must be carried out by a qualified company (e.g. Authorised After-Sales Assistance).

3.8 PROGRAMMING THE P.C.B.

The boiler is prepared for possible programming of several operation parameters. By modifying these parameters as described below, the boiler can be adapted according to specific needs.

To access the programming phase, position the DHW selector (5) on position "6", the CH selector (6) on position "9" and press the "Reset" (3) and "Summer/Winter" buttons for about 8 seconds (2).

Once the menu has been accessed, it is possible to scroll through the three sub-menus present (s, p, t) by pressing the "Summer/Winter" (2) button for 1 second.

Use the "DHW regulator" selector (5), to select the parameter (inside the same sub-menu) and rotate the "CH regulator" selector (6) to modify the value according to the range available.

Press the "Reset" button (3) for 1 second to memorise the variation of the parameters. Memorisation is represented via "88" on the indicator (14) for 2 seconds.

Exit the programming mode by waiting for 15 minutes or by pressing the, "Reset" (3) and "Summer/Winter" (2) buttons simultaneously.

Id Parameter	Parameter	Description	Range	Default	Personalized value	
S0	Minimum DHW output	<p>The boiler also has electronic modulation that adapts the boiler potentiality to the effective heating demand of the house. Therefore the boiler works normally in a variable gas pressure field between minimum and maximum power depending on the system heat load, setting fan speed (in rpm, hundreds of revs are represented on the display).</p> <p>N.B.: the boiler is produced and calibrated in the central heating phase at nominal output. Approximately 10 minutes are needed to reach the nominal heat output, which can be changed using the parameter (S3).</p> <p>N.B.: selection of parameters in the presence of requests, allows boiler functioning with current equal to the respective value.</p>	900 ÷ 1500	Victrix Exa 28 1ErP=1400 Victrix Exa 32 1ErP=1200		
S1	Maximum DHW output		3500 ÷ 6100	28 1ErP G20 = 5300 G30 = 4900 G31 = 5300 G25 = 5300 G27 = 5300 32 1ErP G20 = 4050 G30 = 3700 G31 = 4050 G25 = 4050 G27 = 4050		
S2	Minimum CH output		S0 ÷ S3	Victrix Exa 28 1ErP=1400 Victrix Exa 32 1ErP=1200		
S3	Maximum CH output		S2 ÷ S1	Victrix Exa 28 1ErP=4600 Victrix Exa 32 1ErP=3600		
S4	Power block		1500 ÷ 3500	Victrix Exa 28 1ErP=2000 Victrix Exa 32 1ErP=2300		
S5	Central heating set point minimum temperature		Defines the minimum flow temperature.	20 ÷ 50 °C	25	
S6	Central heating set point maximum temperature		Defines the maximum flow temperature.	(S5+5) ÷ 85 °C	85	
S7	External probe correction		If the reading of the external probe is not correct it is possible to correct it in order to compensate any environmental factors. (Over the value of +9 the display shows "CE", which enables an external control function of the boiler for coupling of the same with a system supervisor)	-9 ÷ 9 K	0	
S8	Boiler power	Identifies the boiler's power (only useful with a coupled storage tank and parameter P0=1).	0 = 12 kW 1 = 26 kW 2 = 28 kW 3 = 32 kW	1		

Id Parameter	Parameter	Description	Range	Default	Personalized value
P0	DHW thermostat	Establishes the switch-off method in DHW mode. 1 Correlated: the boiler switches off according to the temperature set. 0 and 2 Fixed: the switch-off temperature is fixed at the maximum value regardless of the value set on the control panel.	0 - 2	2	
P1	Solar delay timing	The boiler is set to switch-on immediately after a request. for DHW In the case of coupling with a solar storage tank positioned upstream from the boiler, it is possible to compensate the distance between the storage tank and the boiler in order to allow the water to reach the boiler. Set the time necessary to verify that the water is hot enough (see par. Solar panels coupling)	0 - 30 seconds	0	
P2	Pump functioning	The pump can function in two ways. 0 intermittent: in winter "mode" the circulator is managed by the room thermostat or by the remote control 1 continuous: in "winter" mode the circulator is always powered and is therefore always in operation	0 - 1	0	
P3	Relay 1 (optional)	The boiler is set-up for functioning with the relay P.C.B. (optional), which can be configured 0 = Off 1 = Main zone control 2 = General alarm 3 = CH phase active 4 = External gas valve power supply 5 = (Do not use on this boiler model)	0 - 5	1	
P4	Relay 2 (optional)	The boiler is set-up for functioning with the relay P.C.B. (optional), which can be configured 0 = Off 1 = General alarm 2 = CH phase active 3 = External gas valve power supply 4 = Secondary zone control (from TA on relay P.C.B. contact) 5 = Heat pump	0 - 5	0	
P5	Relay 3 (optional)	The boiler is set-up for functioning with the relay P.C.B. (optional), which can be configured 0 = Off 1 = Chiller remote activation 2 = General alarm 3 = CH phase active 4 = External gas valve power supply 5 = heat pump 6 = activation of storage tank pump	0 - 6	0	

Id Parameter	Parameter	Description	Range	Default	Personalized value
t0	Central heating ignitions timer	The boiler has electronic timing, which prevents the burner from igniting too often in central heating mode (with step of 10)	0 - 600 seconds	18	
t1	Central heating ramp timer	In the ignition phase, the boiler performs an ignition ramp in order to arrive at the maximum power set (with step of 10)	0 - 840 seconds	18	
t2	CH ignition delay from TA and CR request	The boiler is set to switch-on immediately after a request. In the case of particular systems (e.g. area systems with motorised thermostatic valves etc.) it could be necessary to delay switch-on (with 10 step)	0 - 600 seconds	0	
t3	Display lighting	Establishes the display lighting mode. 0 Automatic : the display lights up during use and dims after 15 seconds of inactivity. In the event of an anomaly the display flashes. 1 Low : the display is always lit with low intensity 2 High : the display is always lit with high intensity.	0 - 2	0	
t4	Display	Establishes what the indicator displays 14 (Fig. 2-1). "Summer" mode: 0: the indicator is always off 1: circulator active, it displays the flow temperature pump off the indicator is off "Winter" mode: 0: it always displays the value set on the central heating selector 1: circulator active, it displays the flow temperature pump off always displays the value set on the CH selector	0 - 1	1	

3.9 SOLAR PANELS COUPLING FUNCTION.

The boiler is set-up to receive pre-heated water from a system of solar panels up to a maximum temperature of 65°C. In all cases, it is always necessary to install a mixing valve on the hydraulic circuit upstream from the boiler on the cold water inlet.

Note: in order for the boiler to work properly, the temperature selected on the solar valve must be 5°C greater than the temperature selected on the boiler control panel.

In this condition, parameter P0 (DHW thermostat) must be set at "1" and parameter P1 (solar delay time) must be set for a period that is sufficient to receive water from a storage tank located upstream of the boiler. The greater the distance from the storage tank, the longer the stand-by time to be set. Once these adjustments have been made, when the temperature of the boiler inlet water is the same or greater than that set by the DHW selector switch, the boiler does not switch on.

3.10 "CHIMNEY SWEEP" FUNCTION.



When activated, this function forces the boiler to variable output for 15 minutes.

In this state all adjustments are excluded and only the safety thermostat and the limit thermostat remain active. To activate the chimney sweep function, press the "Reset" button (3) until activation of the function in the absence of DHW requests.

Its activation is signalled by simultaneous flashing of the indicators (11 and 12 Fig. 2-1).

This function allows the technician to check the combustion parameters.

Once the function is activated, it is possible to select whether to make the check in CH status or DHW status by opening any hot water cock and regulating the power by turning the "CH regulation" selector (6).

The central heating or DHW operating mode is displayed by the relative symbols  or .

After the checks, deactivate the function switching the boiler off and then on again.

3.11 PUMP ANTI-BLOCK FUNCTION.

The boiler has a function that starts the pump at least once every 24 hours for the duration of 30 seconds in order to reduce the risk of the pump becoming blocked due to prolonged inactivity.

3.12 THREE-WAY ANTI-BLOCK FUNCTION.

Both in "domestic hot water" and in "domestic hot water-central heating" phase the boiler is equipped with a function that starts the three-way motorised group 24 hours after it was last in operation, running it for a full cycle so as to reduce the risk of the three-way group becoming blocked due to prolonged inactivity.

3.13 RADIATORS ANTIFREEZE FUNCTION.

If the system return water is below 4°C, the boiler starts up until reaching 42°C.

3.14 P.C.B. PERIODICAL SELF-CHECK.

During functioning in central heating mode or with boiler in standby, the function activates every 18 hours after the last boiler check/power supply. In case of functioning in domestic hot water mode the self-check starts within 10 minutes after the end of the withdrawing in progress, for duration of approx. 10 seconds.

N.B.: during self-check, the boiler remains off.

3.15 AUTOMATIC VENT FUNCTION.

In the case of new central heating systems and in particular mode for floor systems, it is very important that deaeration is performed correctly. The function consists of the cyclic activation of the pump (100 s ON, 20 s OFF) and the 3-way valve (120 s domestic hot water, 120 s central heating). The function is activated in two different ways:

- every time the boiler is powered;
- by pressing the buttons at the same time (2 and 4 Fig. 2-1) for 5 seconds with the boiler in stand-by.

IMPORTANT NOTE: if the boiler is connected to the CAR^{V2} the "stand-by" function can only be activated via the remote control panel.

In the first case, the function has duration of 8 minutes and it can be interrupted by pressing the "reset" button (4). In the second case it has duration of 18 hours and it can be interrupted by simply switching the boiler on.

Activation of the function is signalled by the countdown shown on the indicator (14).

3.16 APPLIANCE CHECK AND MAINTENANCE.

The following checks and maintenance should be performed at least once a year.

- Clean the flue side of the heat exchanger.
- Clean the main burner.
- If deposits are detected in the combustion chamber one must remove them and clean the heat exchanger coils using nylon or sorghum brushes; it is forbidden to use brushes made of metal or other materials that may damage the combustion chamber itself.
- Check the integrity of the insulating panels inside the combustion chamber and if damaged replace them.
- Visually check for water leaks or oxidation from/on fittings and traces of condensate residues inside the sealed chamber.
- Check contents of the condensate drain trap.
- Via the condensate drain cap check that there are no residues of material that clog condensate passage; also check that the entire condensate drain circuit is clear and efficient.

In the event of obstructions (dirt, sediment, etc.) with consequent leakage of condensate in the combustion chamber, one must replace the insulating panels.

- Check that the burner seal gaskets and the lid are intact and perfectly efficient, otherwise replace them. In any case the gaskets must be replaced at least every two years, regardless of their state of wear.
- Check that the burner is intact, that it has no deformations or cuts and that it is properly fixed to the combustion chamber lid; otherwise it must be replaced.
- Visually check that the water safety drain valve is not clogged.
- Check that, after discharging system pressure and bringing it to zero (read on boiler pressure gauge), the expansion vessel pressure is at 1.0 bar.
- Check that the system static pressure (with system cold and after refilling the system by means of the filling cock) is between 1 and 1.2 bar.
- Visually check that the safety and control devices have not been tampered with and/or shorted, in particular:
 - temperature safety thermostat;
- Check the condition and integrity of the electrical system and in particular:
 - supply voltage cables must be inside the fairleads;
 - there must be no traces of blackening or burning.
- Check ignition and operation.
- Check correct calibration of the burner in domestic hot water and central heating phases.
- Check the operation of the appliance control and adjustment devices and in particular:
 - system regulation probes intervention;
 - domestic hot water control thermostat intervention.
- Check sealing efficiency of the gas circuit and the internal system.
- Check the intervention of the device against no gas ionisation flame control. The relative intervention time must be less than 10 seconds.

IMPORTANT NOTE: in addition to yearly maintenance, you must also check the thermal system and energy efficiency, with the frequency and procedures that comply with the technical regulations in force.

3.17 CASING REMOVAL.

To facilitate boiler maintenance the casing can be completely removed as follows:

• **Lower grid (Fig. 3-5a).**

- 1) Loosen the screws (2).
- 2) Remove the grid (1).

• **Front panel (Fig. 3-5b).**

- 3) Remove the cover caps (3) and loosen the screws (4).
- 4) Tilt the control panel (5) towards you.

• **Casing (Fig. 3-5c).**

- 5) Remove the screws (6) that lock the front casing (7) and the two sides (9).
- 6) Pull the front casing slightly (7) in the lower part towards yourself and push upwards at the same time.
- 7) Loosen the screws (8) on the sides (9).
- 8) Remove the sides by pulling them towards you in order to extract them from the 2 rear seats (Ref. X).

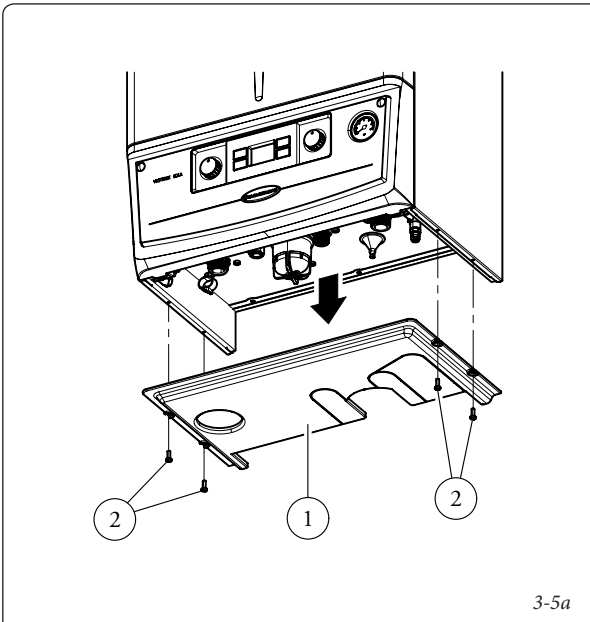

3-5a

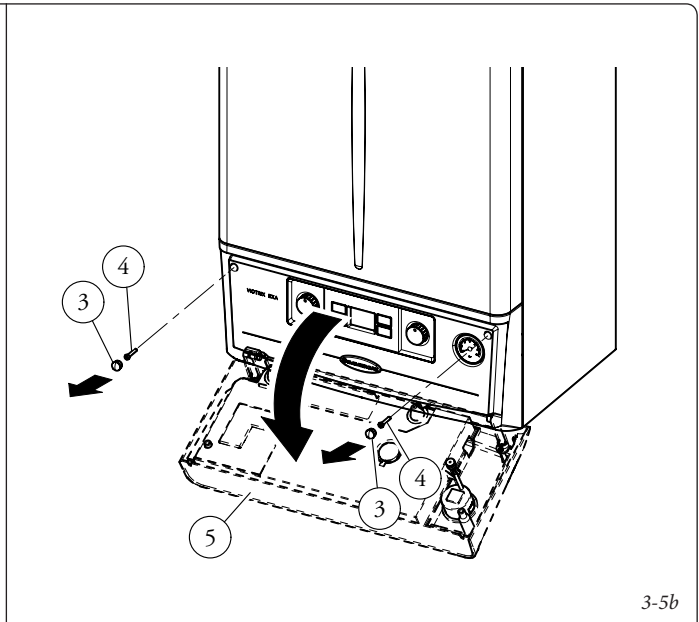

3-5b

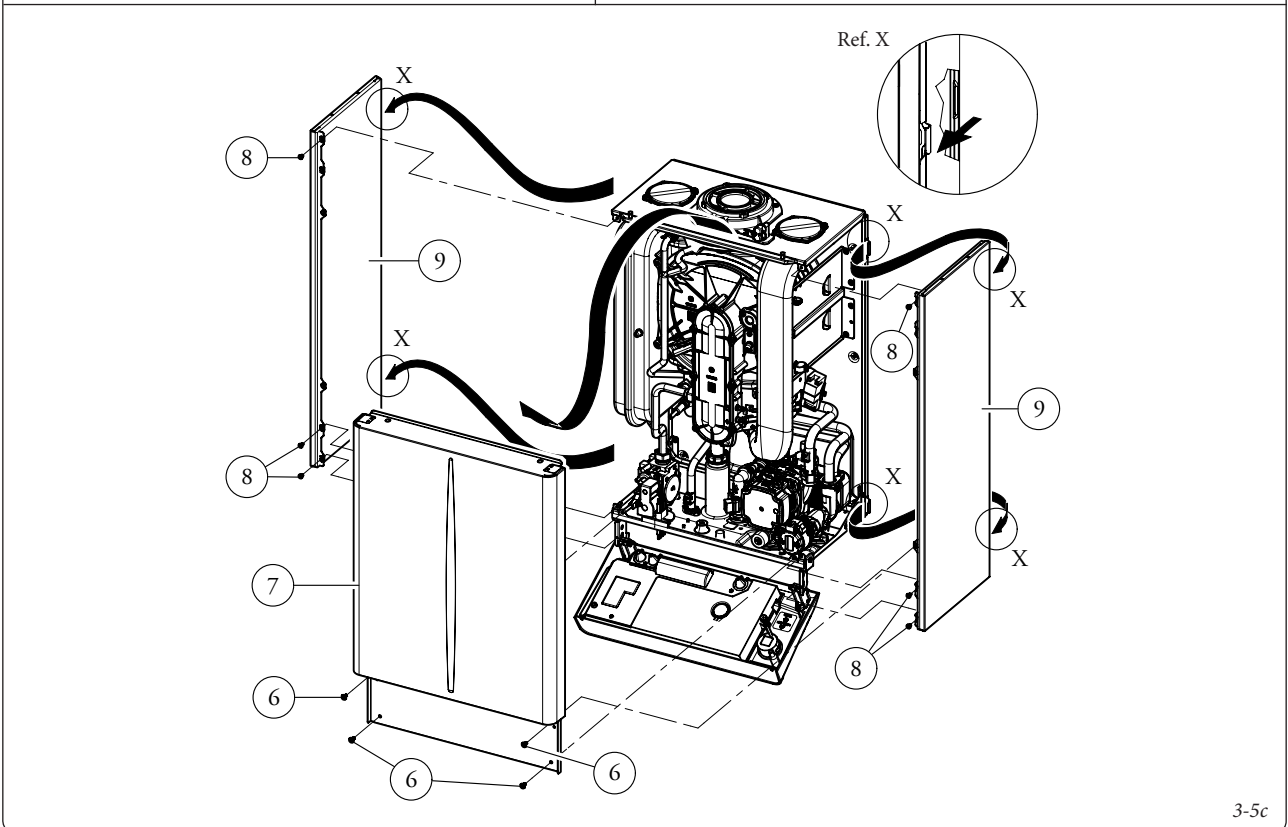

3-5c

3.18 VARIABLE HEAT OUTPUT.

N.B.: the pressures indicated in the table represent the differences of pressures at the ends of the Venturi mixer and can be measured from the pressure points in the upper part of the sealed

chamber (see pressure test 17 and 18 Fig. 1-31). The adjustments must be made with a digital differential pressure gauge with scale in tenths of a mm or Pascal. The power data in the table has been obtained with an intake-exhaust pipe

measuring 0.5 m in length. Gas flow rates refer to the lower calorific value at a temperature of 15°C and at a pressure of 1013 mbar. The burner pressure values refer to the use of gas at a temperature of 15°C.

Victrix EXA 28 1 ErP

	THERMAL POWER		METHANE (G20)			BUTANE (G30)			PROPANE (G31)		
			BURNER GAS FLOW RATE	PRESS. BURNER NOZZLES		BURNER GAS FLOW RATE	PRESS. BURNER NOZZLES		BURNER GAS FLOW RATE	PRESS. BURNER NOZZLES	
	(kW)	(kcal/h)	(m³/h)	(mbar)	(mm H ₂ O)	(kg/h)	(mbar)	(mm H ₂ O)	(kg/h)	(mbar)	(mm H ₂ O)
MAX. D.H.W.	27.7	23822	3.00	3.20	32.6	2.24	3.40	34.7	2.20	4.00	40.8
MAX. CEN. HEAT.	23.7	20382	2.56	2.41	24.5	1.91	2.57	26.2	1.88	2.99	30.5
OUTPUT	5.5	4730	0.60	0.17	1.7	0.45	0.18	1.8	0.44	0.21	2.1

Victrix EXA 32 1 ErP

	THERMAL POWER		METHANE (G20)			BUTANE (G30)			PROPANE (G31)		
			BURNER GAS FLOW RATE	PRESS. BURNER NOZZLES		BURNER GAS FLOW RATE	PRESS. BURNER NOZZLES		BURNER GAS FLOW RATE	PRESS. BURNER NOZZLES	
	(kW)	(kcal/h)	(m³/h)	(mbar)	(mm H ₂ O)	(kg/h)	(mbar)	(mm H ₂ O)	(kg/h)	(mbar)	(mm H ₂ O)
MAX. D.H.W.	32.0	27520	3.44	1.95	19.9	2.57	2.30	23.5	2.52	2.75	28.0
MAX. CEN. HEAT.	28.0	24080	3.00	1.50	15.3	2.24	1.79	18.3	2.21	2.13	21.7
OUTPUT	7.2	6192	0.79	0.15	1.5	0.59	0.18	1.8	0.58	0.20	2.0

3.19 COMBUSTION PARAMETERS.

		G20	G30	G31
Supply pressure	mbar (mm H ₂ O)	20 (204)	29 (296)	37 (377)
Victrix EXA 28 1 ErP				
Gas nozzle diameter (Gas valve 848)	mm	7.00	4.80	5.00
Venturi diameter	mm	22,00	22,00	22,00
No. x Ø venturi holes	mm	4 x 4,00	4 x 4,00	4 x 4,00
Flue flow rate at nominal heat output	kg/h	45	41	45
Flue flow rate at min heat output	kg/h	10	9	9
CO ₂ at Q _{Nom} /Min.	%	9.40 / 8.60	12.00 / 11.40	10.80 / 10.40
CO with 0% O ₂ at Nom./Min. Q _{Nom} /Min.	ppm	190 / 5	580 / 14	250 / 9
NO _x at 0% of O ₂ at Q _{Nom} /Min.	mg/kWh	40 / 25	94 / 55	35 / 20
Flue temperature at nominal output	°C	53	60	59
Flue temperature at minimum output	°C	46	46	44
Victrix EXA 32 1 ErP				
Gas nozzle diameter (Gas valve 848)	mm	WITHOUT	5.70	5.70
Venturi diameter	mm	24,00	24,00	24,00
No. x Ø venturi holes	mm	4 x 4,00	4 x 4,00	4 x 4,00
Flue flow rate at nominal heat output	kg/h	51	46	52
Flue flow rate at min heat output	kg/h	13	12	13
CO ₂ at Q _{Nom} /Min.	%	9.60 / 8.70	12.30 / 11.10	10.50 / 9.70
CO with 0% O ₂ at Nom./Min. Q _{Nom} /Min.	ppm	165 / 3	470 / 5	140 / 3
NO _x at 0% of O ₂ at Q _{Nom} /Min.	mg/kWh	71 / 17	270 / 35	90 / 22
Flue temperature at nominal output	°C	62	62	61
Flue temperature at minimum output	°C	56	57	55

Combustion parameters: measuring conditions of useful efficiency (flow temperature/return temperature= 80/60 °C), ambient temperature reference = 15°C.

INSTALLER

USER

MAINTENANCE TECHNICIAN

3.20 TECHNICAL DATA.

		Victrix EXA 28 1 ErP	Victrix EXA 32 1 ErP
Domestic hot water nominal heat input	kW (kcal/h)	28.4 (24408)	32.5 (27939)
Central heating nominal heat input	kW (kcal/h)	24.2 (20785)	28.4 (24411)
Minimum heat input	kW (kcal/h)	5.7 (4866)	7.4 (6403)
Domestic hot water nominal heat output (useful)	kW (kcal/h)	27.7 (23822)	32.0 (27520)
Central heating nominal heat output (useful)	kW (kcal/h)	23.7 (20382)	28.0 (24080)
Minimum heat output (useful)	kW (kcal/h)	5.5 (4730)	7.2 (6192)
* Effective thermal efficiency 80/60 Nom./Min.	%	98.1 / 97.2	98.6 / 96.7
* Effective thermal efficiency 50/30 Nom./Min.	%	106.0 / 106.5	108.0 / 105.9
* Effective thermal efficiency 40/30 Nom./Min.	%	107.2 / 107.8	109.0 / 106.0
Casing losses with burner On/Off (80-60°C)	%	0.47 / 0.6	0.26 / 0.3
Heat loss at flue with burner On/Off (80-60°C)	%	0.01 / 1.8	0.01 / 1.2
Central heating circuit max. operating pressure	bar	3.0	3.0
Maximum heating temperature	°C	90	90
Adjustable central heating temperature	°C	20 - 85	20 - 85
System expansion vessel total volume	l	5.0	5.0
Expansion vessel factory-set pressure	bar	1.0	1.0
Appliance water content	l	3.4	3.1
Head available with 1000 l/h flow rate	kPa (m H ₂ O)	29.6 (3.0)	29.6 (3.0)
Hot water production useful heat output	kW (kcal/h)	27.7 (23822)	32.0 (27520)
Domestic hot water adjustable temperature	°C	30 - 60	30 - 60
Domestic hot water circuit min. pressure (dynamic)	bar	0.3	0.3
Domestic hot water circuit max. operating pressure	bar	10.0	10.0
Minimum D.H.W. flow rate	l/min	1.5	1.5
Flow rate capacity in continuous duty (ΔT 30°C)	l/min	13.7	15.3
Weight of full boiler	kg	40.4	42.1
Weight of empty boiler	kg	37.0	39.0
Electrical connection	V/Hz	230 / 50	230 / 50
Nominal power absorption	A	0.56	0.62
Installed electric power	W	76	90
Pump absorbed power	W	40	56
Fan power absorbed power	W	22	17
Pump system EEI value	-	≤ 0.20 - Part. 3	≤ 0.20 - Part. 3
Equipment electrical system protection	-	IPX5D	IPX5D
Max temperature of combustion products	°C	75	75
NO _x class	-	5	5
Weighted NO _x	mg/kWh	41	36
Weighted CO	mg/kWh	14	27
Type of appliance	C13 / C13x / C33 / C33x / C43 / C43x / C53 / C63 / C83 / C93 / C93x / B23p / B33		
Category	II 2H3B/P		

- The data relating to domestic hot water performance refer to a dynamic inlet pressure of 2 bar and an inlet temperature of 15°C; the values are measured immediately at the boiler outlet, considering that to obtain the data declared, mixing with cold water is required.

- * Efficiencies refer to the net calorific value.

3.21 KEY FOR DATA NAMEPLATE.

Md		Cod. Md	
Sr N°	CHK	Cod. PIN	
Type			
Q _{nw} /Q _n min.	Q _{nw} /Q _n max.	P _n min.	P _n max.
PMS	PMW	D	TM
NO _x Class			
		CONDENSING	

N.B.: the technical data is provided on the data plate on the boiler

	IE
Md	Model
Cod. Md	Model code
Sr N°	Serial Number
CHK	Check
Cod. PIN	PIN code
Type	Type of installation (ref. CEN TR 1749)
Q _{nw} min.	Minimum DHW heat input
Q _n min.	CH minimum heat input
Q _{nw} max.	DHW maximum heat input
Q _n max.	CH maximum heat input
P _n min.	Minimum heat output
P _n max.	Maximum heat output
PMS	Maximum system pressure
PMW	Maximum domestic hot water pressure
D	Specific flow rate
TM	Maximum operating temperature
NO _x Class	NO _x Class
CONDENSING	Condensing boiler

3.22 TECHNICAL PARAMETERS FOR COMBINATION BOILERS (IN COMPLIANCE WITH REGULATION 813/2013).

Efficiencies in the following tables refer to the gross calorific value.

Model/s:				Victrix EXA 28 1 ErP				
Condensing Boilers:				SI				
Low temperature boiler:				NO				
Boiler type B1:				NO				
Co-generation appliance for central heating:				NO			Fitted with supplementary heating system:	NO
Mixed heating appliance:				SI				
Element	Symbol	Value	Unit	Element	Symbol	Value	Unit	
Nominal heat output	P_n	24	kW	Seasonal energy efficiency of central heating	η_s	92	%	
For central heating only and combination boilers: useful heat output				For central heating only and combination boilers: useful efficiency				
At nominal heat output in high temperature mode (*)	P_4	23.7	kW	At nominal heat output in high temperature mode (*)	η_4	88.4	%	
At 30% of nominal heat output in a low temperature mode (**)	P_1	7.8	kW	At 30% of nominal heat output in a low temperature mode (**)	η_1	97.0	%	
Auxiliary electricity consumption				Other items				
At full load	el_{max}	0.039	kW	Heat loss in standby	P_{stby}	0.078	kW	
At partial load	el_{min}	0.019	kW	Ignition burner energy consumption	P_{ign}	0.000	kW	
In standby mode	P_{SB}	0.006	kW	Emissions of nitrogen oxides	NO_x	40	mg / kWh	
For mixed central heating appliances								
Stated load profile		XL		Domestic hot water production efficiency	η_{WH}	86	%	
Daily electrical power consumption	Q_{elec}	0.214	kWh	Daily gas consumption	Q_{fuel}	22.398	kWh	
Contact information		IMMERGAS S.p.A. VIA CISA LIGURE, 95 - 42041 BRESCELLO (RE) ITALY						

(*) High temperature mode means 60°C on return and 80°C on flow.
(**) Low temperature mode for condensation Boilers means 30°C , for low temperature boilers 37°C and for other appliances 50°C of return temperature.

Model/s:				Victrix EXA 32 1 ErP				
Condensing Boilers:				SI				
Low temperature boiler:				NO				
Boiler type B1:				NO				
Co-generation appliance for central heating:				NO			Fitted with supplementary heating system:	NO
Mixed heating appliance:				SI				
Element	Symbol	Value	Unit	Element	Symbol	Value	Unit	
Nominal heat output	P_n	28	kW	Seasonal energy efficiency of central heating	η_s	92	%	
For central heating only and combination boilers: useful heat output				For central heating only and combination boilers: useful efficiency				
At nominal heat output in high temperature mode (*)	P_4	28.0	kW	At nominal heat output in high temperature mode (*)	η_4	88.8	%	
At 30% of nominal heat output in a low temperature mode (**)	P_1	9.2	kW	At 30% of nominal heat output in a low temperature mode (**)	η_1	96.8	%	
Auxiliary electricity consumption				Other items				
At full load	el_{max}	0.032	kW	Heat loss in standby	P_{stby}	0.042	kW	
At partial load	el_{min}	0.017	kW	Ignition burner energy consumption	P_{ign}	0.000	kW	
In standby mode	P_{SB}	0.006	kW	Emissions of nitrogen oxides	NO_x	32	mg / kWh	
For mixed central heating appliances								
Stated load profile		XL		Domestic hot water production efficiency	η_{WH}	85	%	
Daily electrical power consumption	Q_{elec}	0.215	kWh	Daily gas consumption	Q_{fuel}	22.732	kWh	
Contact information		IMMERGAS S.p.A. VIA CISA LIGURE, 95 - 42041 BRESCELLO (RE) ITALY						

(*) High temperature mode means 60°C on return and 80°C on flow.
(**) Low temperature mode for condensation Boilers means 30°C , for low temperature boilers 37°C and for other appliances 50°C of return temperature.

3.23 PRODUCT FICHE (IN COMPLIANCE WITH REGULATION 811/2013).

Victrix EXA 28 1 ErP

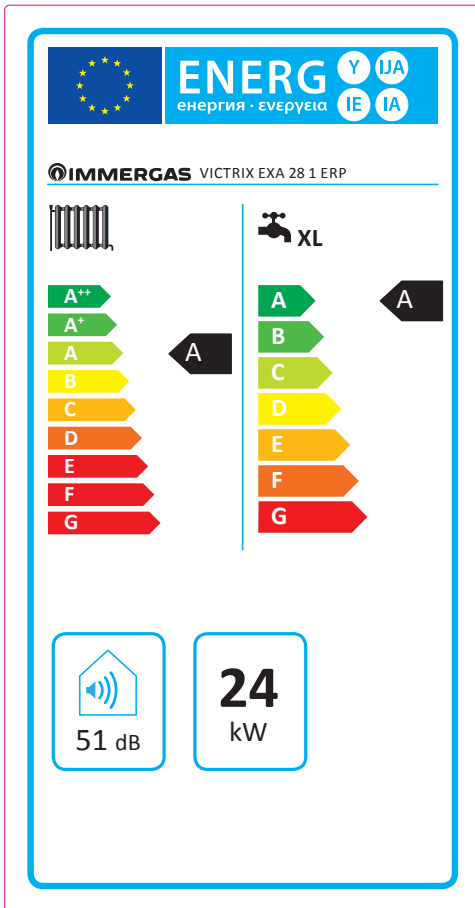

Victrix EXA 32 1 ErP

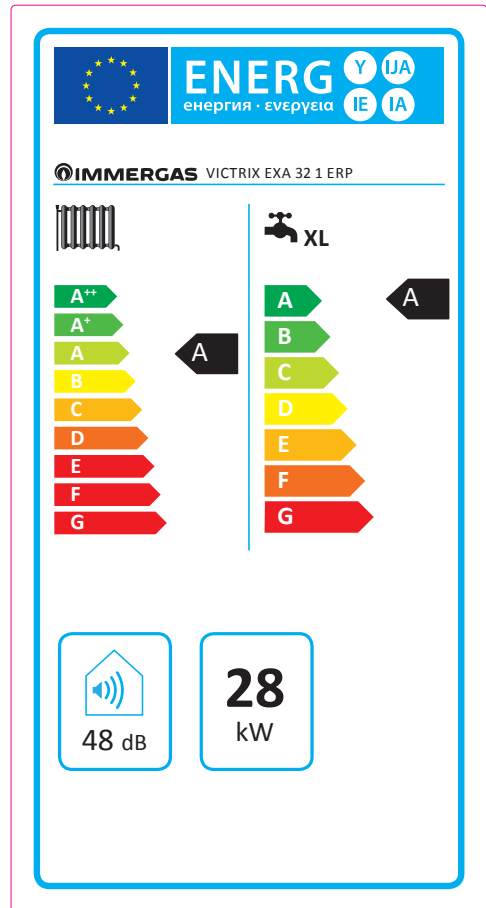

Parameter	value
Annual energy consumption for the heating function (Q_{HE})	74.3 GJ
Annual electricity consumption for the domestic hot water function (AEC)	47 kWh
Annual fuel consumption for the domestic hot water function (AFC)	17 GJ
Seasonal space heating energy efficiency (η_s)	92 %
Water heating energy efficiency (η_{wh})	86 %

Parameter	value
Annual energy consumption for the heating function (Q_{HE})	87.7 GJ
Annual electricity consumption for the domestic hot water function (AEC)	47 kWh
Annual fuel consumption for the domestic hot water function (AFC)	17 GJ
Seasonal space heating energy efficiency (η_s)	92 %
Water heating energy efficiency (η_{wh})	85 %

For proper installation of the appliance refer to chapter 1 of this booklet (for the installer) and current installation regulations. For proper maintenance refer to chapter 3 of this booklet (for the maintenance technician) and adhere to the frequencies and methods set out herein.

3.24 PARAMETERS FOR FILLING IN THE PACKAGE FICHE.

In case you should wish to install an assembly, starting from the Victrix EXA 28 1 ErP - 32 1 ErP boiler, use the assembly charts in Fig. 3-8 and 3-11.

For correctly filling in, enter the figures shown in tables fig. 3-7 and 3-10 (as shown in the facsimile package fiche fig. 3-6 and 3-9).

The remaining values must be obtained from

the technical data sheets of the products used to make up the assembly (e.g. solar devices, integration heat pumps, temperature controllers). Use sheet fig. 3-8 for "assemblies" related to the heating function (e.g.: boiler + temperature controller).

Use sheet fig. 3-11 for "assemblies" related to the domestic hot water function (e.g.: boiler + solar thermal system).

Facsimile for filling in the package fiche for preferential boiler space heaters.

Seasonal space heating energy efficiency of boiler	1 <input type="text" value="'I'"/> %																														
Temperature control From fiche of temperature control	2 + <input type="text"/> %																														
<div style="border: 1px solid black; padding: 5px; width: fit-content; margin: 0 auto;"> Class I = 1 %, Class II = 2 %, Class III = 1.5 %, Class IV = 2 %, Class V = 3 %, Class VI = 4 %, Class VII = 3.5 %, Class VIII = 5 % </div>																															
Supplementary boiler From fiche of boiler	3 ± <input type="text"/> %																														
<div style="border: 1px solid black; padding: 5px; width: fit-content; margin: 0 auto;"> Seasonal space heating energy efficiency (in %) </div> $(\text{ } - \text{'I'}) \times 0,1 = \pm \text{ } \%$																															
Solar contribution																															
From fiche of solar device	4 + <input type="text"/> %																														
<div style="display: flex; justify-content: space-around; align-items: flex-start;"> <div style="border: 1px solid black; padding: 5px; text-align: center;">Collector size (in m²)</div> <div style="border: 1px solid black; padding: 5px; text-align: center;">Tank volume (in m³)</div> <div style="border: 1px solid black; padding: 5px; text-align: center;">Collector efficiency (in %)</div> <div style="border: 1px solid black; padding: 5px; text-align: center;">Tank rating A* = 0.95, A = 0.91, B = 0.86, C = 0.83, D-G = 0.81</div> </div> $(\text{'III'} \times \text{ } + \text{'IV'} \times \text{ }) \times (0,9 \times (\text{ } / 100) \times \text{ } = + \text{ } \%$																															
Supplementary heat pump From fiche of heat pump	5 + <input type="text"/> %																														
<div style="border: 1px solid black; padding: 5px; width: fit-content; margin: 0 auto;"> Seasonal space heating energy efficiency (in %) </div> $(\text{ } - \text{'I'}) \times \text{'II'} = + \text{ } \%$																															
Solar contribution and Supplementary heat pump																															
Select smaller value	6 - <input type="text"/> %																														
$0,5 \times \text{ } \text{ OR } 0,5 \times \text{ } = - \text{ } \%$																															
7 <input type="text"/> %																															
Seasonal space heating energy efficiency of package																															
Seasonal space heating energy efficiency class of package																															
<div style="border: 1px solid black; padding: 10px; width: fit-content; margin: 0 auto;"> <table style="width: 100%; text-align: center; border-collapse: collapse;"> <tr> <td><input type="checkbox"/></td><td><input type="checkbox"/></td><td><input type="checkbox"/></td><td><input type="checkbox"/></td><td><input type="checkbox"/></td><td><input type="checkbox"/></td><td><input type="checkbox"/></td><td><input type="checkbox"/></td><td><input type="checkbox"/></td><td><input type="checkbox"/></td> </tr> <tr> <td>G</td><td>F</td><td>E</td><td>D</td><td>C</td><td>B</td><td>A</td><td>A⁺</td><td>A⁺⁺</td><td>A⁺⁺⁺</td> </tr> <tr> <td>< 30 %</td><td>≥ 30 %</td><td>≥ 34 %</td><td>≥ 36 %</td><td>≥ 75 %</td><td>≥ 82 %</td><td>≥ 90 %</td><td>≥ 98 %</td><td>≥ 125 %</td><td>≥ 150 %</td> </tr> </table> </div>		<input type="checkbox"/>	<input type="checkbox"/>	<input type="checkbox"/>	<input type="checkbox"/>	<input type="checkbox"/>	<input type="checkbox"/>	<input type="checkbox"/>	<input type="checkbox"/>	<input type="checkbox"/>	<input type="checkbox"/>	G	F	E	D	C	B	A	A⁺	A⁺⁺	A⁺⁺⁺	< 30 %	≥ 30 %	≥ 34 %	≥ 36 %	≥ 75 %	≥ 82 %	≥ 90 %	≥ 98 %	≥ 125 %	≥ 150 %
<input type="checkbox"/>	<input type="checkbox"/>	<input type="checkbox"/>	<input type="checkbox"/>	<input type="checkbox"/>	<input type="checkbox"/>	<input type="checkbox"/>	<input type="checkbox"/>	<input type="checkbox"/>	<input type="checkbox"/>																						
G	F	E	D	C	B	A	A⁺	A⁺⁺	A⁺⁺⁺																						
< 30 %	≥ 30 %	≥ 34 %	≥ 36 %	≥ 75 %	≥ 82 %	≥ 90 %	≥ 98 %	≥ 125 %	≥ 150 %																						
Boiler and supplementary heat pump installed with low temperature heat emitters at 35°C?																															
From fiche of heat pump	7 <input type="text"/> + (50 x 'II') = <input type="text"/> %																														
<p>The energy efficiency of the package of products provided far in this fiche may not correspond to its actual energy efficiency once installed in a building, as the efficiency is influenced by further factors such as heat loss in the distribution system and the dimensioning of the products in relation to building size and characteristics.</p>																															

Parameters for filling in the assembly chart.

Parameter	Victrix EXA 28 1 ErP	Victrix EXA 32 1 ErP
'I'	92	92
'II'	*	*
'III'	1.11	0.95
'IV'	0.43	0.37

* to be established by means of table 5 of Regulation 811/2013 in case of "assembly" including a heat pump to integrate the boiler. In this case the boiler must be considered as the main appliance of the assembly.

3-7

Room heating system package fiche.

Seasonal space heating energy efficiency of boiler 1 %

Temperature control
From fiche of temperature control 2 %

Class I = 1 %, Class II = 2 %,
 Class III = 1.5 %, Class IV = 2 %,
 Class V = 3 %, Class VI = 4 %,
 Class VII = 3.5 %, Class VIII = 5 %

Supplementary boiler
From fiche of boiler 3 %

Seasonal space heating energy efficiency (in %)

$$(\text{ } - \text{ }) \times 0.1 = \pm \text{ } \%$$

Solar contribution
From fiche of solar device 4 %

Collector size (in m²)

Tank volume (in m³)

Collector efficiency (in %)

Tank rating
A* = 0.95, A = 0.91,
B = 0.86, C = 0.83,
D-G = 0.81

$$(\text{ } \times \text{ } + \text{ } \times \text{ }) \times (0.9 \times (\text{ } / 100) \times \text{ } = + \text{ } \%$$

Supplementary heat pump
From fiche of heat pump 5 %

Seasonal space heating energy efficiency (in %)

$$(\text{ } - \text{ }) \times \text{ } = + \text{ } \%$$

Solar contribution and Supplementary heat pump
Select smaller value 6 %

$$0.5 \times \text{ } \text{ OR } 0.5 \times \text{ } = - \text{ } \%$$

Seasonal space heating energy efficiency of package 7 %

Seasonal space heating energy efficiency class of package

<input type="checkbox"/>	<input type="checkbox"/>	<input type="checkbox"/>	<input type="checkbox"/>	<input type="checkbox"/>	<input type="checkbox"/>	<input type="checkbox"/>	<input type="checkbox"/>	<input type="checkbox"/>	<input type="checkbox"/>
G	F	E	D	C	B	A	A ⁺	A ⁺⁺	A ⁺⁺⁺
< 30 %	≥ 30 %	≥ 34 %	≥ 36 %	≥ 75 %	≥ 82 %	≥ 90 %	≥ 98 %	≥ 125 %	≥ 150 %

Boiler and supplementary heat pump installed with low temperature heat emitters at 35°C?

From fiche of heat pump 7 %

$$\text{ } + (50 \times \text{ }) = \text{ } \%$$

The energy efficiency of the package of products provided far in this fiche may not correspond to its actual energy efficiency once installed in a building, as the efficiency is influenced by further factors such as heat loss in the distribution system and the dimensioning of the products in relation to building size and characteristics.

3-8

Facsimile for filling in domestic hot water production system package fiche.

Water heating energy efficiency of combination heater

¹
 %

Declared load profile:

Solar contribution

From fiche of solar device

Auxiliary electricity

$$(1,1 \times \text{'I'} - 10\%) \times \text{'II'} - \text{'III'} - \text{'I'} = + \text{} \%$$

Water heating energy efficiency of package under average climate

³
 %

Water heating energy efficiency class of package under average climate

	<input type="checkbox"/>	<input type="checkbox"/>	<input type="checkbox"/>	<input type="checkbox"/>	<input type="checkbox"/>	<input type="checkbox"/>	<input type="checkbox"/>	<input type="checkbox"/>	<input type="checkbox"/>	<input type="checkbox"/>
	G	F	E	D	C	B	A	A⁺	A⁺⁺	A⁺⁺⁺
<input type="checkbox"/> M	< 27 %	≥ 27 %	≥ 30 %	≥ 33 %	≥ 36 %	≥ 39 %	≥ 65 %	≥ 100 %	≥ 130 %	≥ 163 %
<input type="checkbox"/> L	< 27 %	≥ 27 %	≥ 30 %	≥ 34 %	≥ 37 %	≥ 50 %	≥ 75 %	≥ 115 %	≥ 150 %	≥ 188 %
<input type="checkbox"/> XL	< 27 %	≥ 27 %	≥ 30 %	≥ 35 %	≥ 38 %	≥ 55 %	≥ 80 %	≥ 123 %	≥ 160 %	≥ 200 %
<input type="checkbox"/> XXL	< 28 %	≥ 28 %	≥ 32 %	≥ 36 %	≥ 40 %	≥ 60 %	≥ 85 %	≥ 131 %	≥ 170 %	≥ 213 %

Water heating energy efficiency under colder and warmer climate conditions

Colder: ³ - 0.2 x ² = %

Warmer: ³ + 0.4 x ² = %

The energy efficiency of the package of products provided far in this fiche may not correspond to its actual energy efficiency once installed in a building, as the efficiency is influenced by further factors such as heat loss in the distribution system and the dimensioning of the products in relation to building size and characteristics.

Parameters for filling in DHW package assembly chart.

Parameter	Victrix EXA 28 1 ErP	Victrix EXA 32 1 ErP
'I'	86	85
'II'	*	*
'III'	*	*

* to be determined according to Regulation 811/2013 and transient calculation methods as per Notice of the European Community no. 207/2014.

3-10

Domestic hot water production system package fiche.

Water heating energy efficiency of combination heater

%

Declared load profile:

Solar contribution

From fiche of solar device

Auxiliary electricity

(1,1 x - 10 %) x - =

+ %

Water heating energy efficiency of package under average climate

%

Water heating energy efficiency class of package under average climate

	<input type="checkbox"/>	<input type="checkbox"/>	<input type="checkbox"/>	<input type="checkbox"/>	<input type="checkbox"/>	<input type="checkbox"/>	<input type="checkbox"/>	<input type="checkbox"/>	<input type="checkbox"/>	<input type="checkbox"/>
	G	F	E	D	C	B	A	A⁺	A⁺⁺	A⁺⁺⁺
<input type="checkbox"/> M	< 27 %	≥ 27 %	≥ 30 %	≥ 33 %	≥ 36 %	≥ 39 %	≥ 65 %	≥ 100 %	≥ 130 %	≥ 163 %
<input type="checkbox"/> L	< 27 %	≥ 27 %	≥ 30 %	≥ 34 %	≥ 37 %	≥ 50 %	≥ 75 %	≥ 115 %	≥ 150 %	≥ 188 %
<input type="checkbox"/> XL	< 27 %	≥ 27 %	≥ 30 %	≥ 35 %	≥ 38 %	≥ 55 %	≥ 80 %	≥ 123 %	≥ 160 %	≥ 200 %
<input type="checkbox"/> XXL	< 28 %	≥ 28 %	≥ 32 %	≥ 36 %	≥ 40 %	≥ 60 %	≥ 85 %	≥ 131 %	≥ 170 %	≥ 213 %

Water heating energy efficiency under colder and warmer climate conditions

Colder: - 0.2 x = %

Warmer: + 0.4 x = %

The energy efficiency of the package of products provided far in this fiche may not correspond to its actual energy efficiency once installed in a building, as the efficiency is influenced by further factors such as heat loss in the distribution system and the dimensioning of the products in relation to building size and characteristics.



3-11

Follow us

Immergas Italia



immergas.com

Immergas S.p.A.
42041 Brescello (RE) - Italy
Tel. 0522.689011
Fax 0522.680617

Certified company ISO 9001

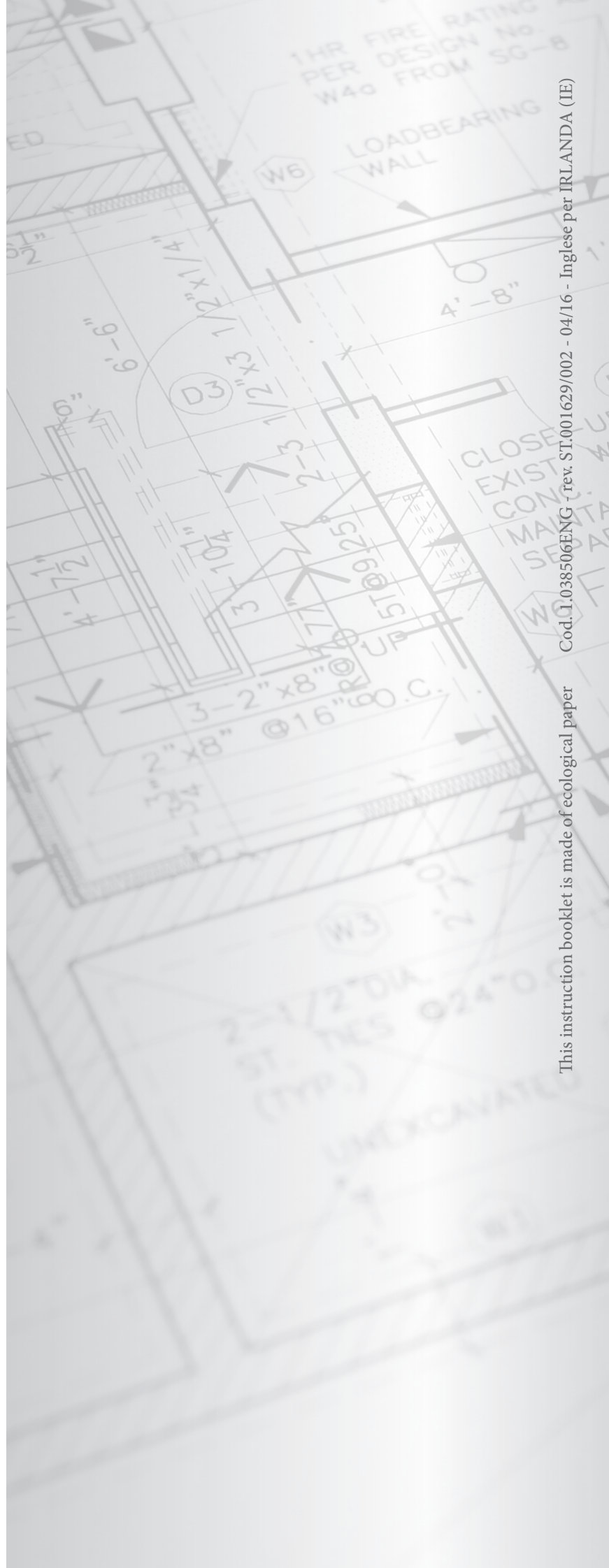

This instruction booklet is made of ecological paper

Cod. I.038506ENG - rev. ST.001629/002 - 04/16 - Inglese per IRLANDA (IE)