



Instruction and
Warning book 

**VICTRIX
X 12-24 2 I**

1.031274IE



Dear Client,

Our compliments for having chosen a top-quality Immergas product, able to assure well-being and safety for a long period of time. As an Immergas customer you can also count on a qualified after-sales service, prepared and updated to guarantee constant efficiency of your boiler. Read the following pages carefully: you will be able to draw useful suggestions regarding the correct use of the appliance, the respect of which, will confirm your satisfaction for the Immergas product. Contact our area authorised after-sales centre as soon as possible to request commissioning. Our technician will verify the correct functioning conditions; he will perform the necessary calibrations and will demonstrate the correct use of the generator.

For any interventions or routine maintenance contact Immergas Authorised Centres: these have original spare parts and boast of specific preparation directly from the manufacturer.

General recommendations

The instruction book is an integral and essential part of the product and must be consigned to the new user also in the case of transfer or succession of ownership. It must be kept well and consulted carefully, as all of the warnings supply important indications for safety in the installation, use and maintenance stages.

In compliance with legislation in force, the systems must be designed by qualified professionals, within the dimensional limits established by the Law. Installation and maintenance must be performed in compliance with the regulations in force, according to the manufacturer's instructions and by professionally qualified staff, intending staff with specific technical skills in the plant sector, as envisioned by the Law.

Incorrect installation can cause injury to persons and animals and damage to objects, for which the manufacturer is not liable. Maintenance must be carried out by skilled technical staff. The Immergas Authorised After-sales Service represents a guarantee of qualifications and professionalism.

The appliance must only be destined for the use for which it has been expressly declared. Any other use will be considered improper and therefore potentially dangerous. If errors occur during installation, running and maintenance, due to the non compliance of technical laws in force, standards or instructions contained in this book (or however supplied by the manufacturer), the manufacturer is excluded from any contractual and extra-contractual liability for any damages and the appliance warranty is invalidated. For further information regarding legislative and statutory provisions relative to the installation of gas heat generators, consult the Immergas site at the following address: www.immergas.com

DECLARATION OF CONFORMITY

For the purpose and effect of the CE 2009/142 Gas Appliance Directive, EMC 2004/108/CE Directive, 92/42/CE Boiler Efficiency Directives and 2006/95/CE Low Voltage Directive.

The Manufacturer: Immergas S.p.A. v. Cisa Ligure n° 95 42041 Brescello (RE)

Mauro Guareschi

Research & Development Director

Signature:

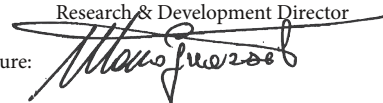

DECLARES THAT: the Immergas boiler model:

Victrix X 12-24 2I

is in compliance with the same European Community Directives

INDEX

INSTALLER	page	USER	page	TECHNICIAN	page
1	Boiler installation.....	2	Instructions for use and maintenance..	3	Boiler start-up (initial check).....
1.1	Installation recommendations.....	2.1	Cleaning and maintenance.....	3.1	Hydraulic diagram.....
1.2	Main dimensions.....	2.2	General warnings.....	3.2	Wiring diagram.....
1.3	Main Dimensions Recess kit (optional). 5	2.3	Control panel.....	3.3	Troubleshooting.....
1.4	Anti-freeze protection.....	2.4	Using the boiler.....	3.4	Converting the boiler to other types of gas.....
1.5	Connections.....	2.5	Troubleshooting.....	3.5	Calibration of number of fan revs.....
1.6	Remote controls and room chronothermostats (Optional).....	2.6	Information menu.....	3.6	Adjustment of the air-gas ratio.....
1.7	External probe (Optional).....	2.7	Boiler shutdown.....	3.7	Checks following conversion to another type of gas.....
1.8	Immergas flue systems.....	2.8	Restore central heating system pressure.....	3.8	Programming the P.C.B.....
1.9	Outdoor installation in partially protected area.....	2.9	System Draining.....	3.9	Solar panels coupling function.....
1.10	Outdoor Installation using recess frame (with direct air intake).....	2.10	Anti-freeze protection.....	3.10	"Chimney sweep" function.....
1.11	Indoor installation.....	2.11	Case cleaning.....	3.11	Pump anti-block function.....
1.12	Ducting of flue technical slots.....	2.12	Decommissioning.....	3.12	three-way anti-block function.....
1.13	Flue exhaust to flue/chimney.....			3.13	Radiators anti-freeze function.....
1.14	Flues, chimneys and chimney caps.....			3.14	P.C.B. periodical self-check.....
1.15	System filling.....			3.15	Automatic vent function.....
1.16	Filling of the condensate trap.....			3.16	System supervisor coupling function..
1.17	Gas system start-up.....			3.17	Yearly appliance check and maintenance.....
1.18	Boiler start up (ignition).....			3.18	Casing removal.....
1.19	Circulation pump.....			3.19	Variable heat output.....
1.20	Kits available on request.....			3.20	Combustion parameters.....
1.21	Boiler components.....			3.21	Technical data.....

Immergas S.p.A. declines all liability due to printing or transcription errors, reserving the right to make any modifications to its technical and commercial documents without forewarning.



INSTALLER

USER

TECHNICIAN

1 BOILER INSTALLATION

1.1 INSTALLATION RECOMMENDATIONS.

The Victrix X 12-24 2I boiler has been designed only for wall mounted installation or installation inside the wall using the recess frame provided; they must be used to heat domestic environments and similar purposes.

In the case of wall installation the wall surface must be smooth, without any protrusions or recesses enabling access to the rear part. They are NOT designed to be installed on plinths or floors (Fig. 1-1).

By varying the type of installation the classification of the boiler also varies, precisely:

- **B₂₃** type boiler
 - if installed using the relevant terminal for air intake directly from the room in which the boiler has been installed.
 - using the spacers under the side plugs of the sealed chamber inside the recess frame kit (optional).
- **Type C boiler** if installed using concentric pipes or other types of pipes envisioned for the sealed chamber boiler for intake of air and expulsion of flue gases.

Only professionally enabled heating/plumbing technicians are authorised to install Immergas gas appliances.

Installation must be carried out according to the standards, current legislation and in compliance with local technical regulations and the required technical procedures.

Before installing the appliance, ensure that it is delivered in perfect condition; if in doubt, contact the supplier immediately. Packing materials (staples, nails, plastic bags, polystyrene foam, etc.) constitute a hazard and must be kept out of the reach of children. If the appliance is installed inside or between cabinets, ensure sufficient space for normal servicing; therefore it is advisable to leave clearance of at least 3 cm between the boiler casing and the vertical sides of the cabinet. Leave adequate space above the boiler for possible water and flue removal connections. Keep all flammable objects away from the appliance (paper, rags, plastic, polystyrene, etc.).

Do not place household appliances underneath the boiler as they could be damaged if the safety valve intervenes (if not conveyed away by a draining funnel), or if there are leaks from the connections; on the contrary, the manufacturer cannot be held responsible for any damage caused to the household appliances.

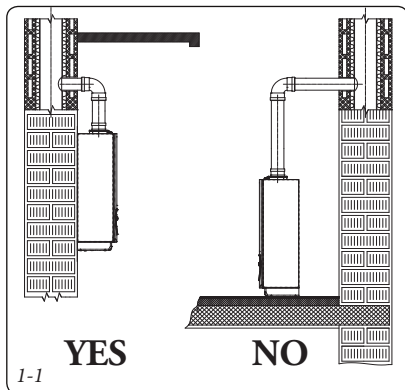

In the event of malfunctions, faults or incorrect operation, turn the appliance off immediately and contact a qualified technician (e.g. the Immergas Technical Assistance centre, which has specifically trained staff and original spare parts) Do not attempt to modify or repair the appliance alone.

Failure to comply with the above implies personal responsibility and invalidates the warranty.

• Installation regulations:

- this boiler can be installed outdoors in a partially protected area. A partially protected area is one in which the appliance is not exposed to the direct action of the weather (rain, snow, hail, etc..).
- Installation in places with a fire risk is prohibited (for example: garages, box), gas appliances and relative flue ducts, flue exhaust pipes and combustion air intake pipes.
- Installation is prohibited on the vertical projection of the cooking surface.
- Installation is also prohibited in places/environments that constitute common parts of office condominiums such as stairs, cellars, entrance halls, attics, lofts, escape routes, etc. if they are not located inside technical compartments under the responsibility of each individual building and only accessible to the user (for the features of the technical compartments, see the Reference Standard).

Important: Wall mounting of the boiler on the wall or inside the wall must guarantee stable and efficient support for the generator. The recessed frame kit (Optional) guarantees an adequate support only if installed correctly (in accordance with the code of practice) following the instructions on the instruction leaflet. The recessed frame for the Victrix X 12-24 2I boiler is not a supporting structure and must not replace the wall removed. It is necessary to position the boiler inside the wall. For safety reasons against any leaks it is necessary to plaster the boiler housing in the brick wall.

The plugs (standard supply) are to be used only in conjunction with the mounting brackets or fixing template to fix the appliance to the wall; they only ensure adequate support if inserted correctly (according to technical standards) in walls made of solid or semi-hollow brick or block. In the case of walls made from hollow brick or block, partitions with limited static properties, or in any case walls other than those indicated, a static test must be carried out to ensure adequate support.

N.B.: the hex head screws supplied in the blister pack are to be used exclusively to fix the relative mounting bracket to the wall.

These boilers are used to heat water to below boiling temperature in atmospheric pressure.

They must be connected to a central heating system and hot water circuit suited to their performance and capacity.

1.2 MAIN DIMENSIONS.

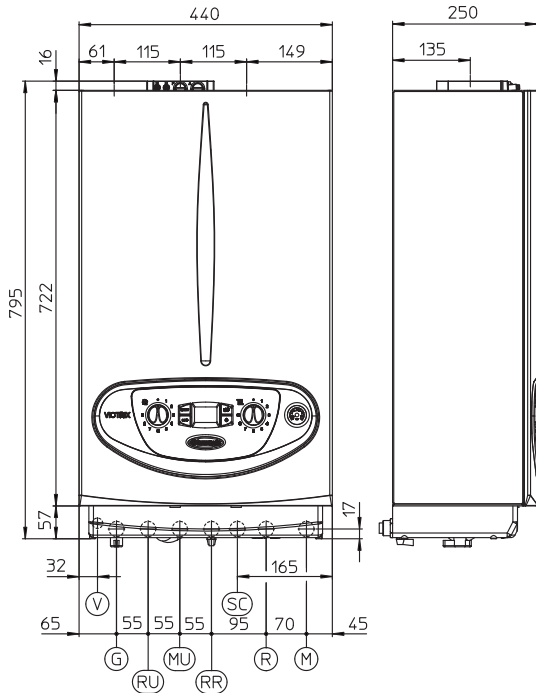

Height (mm)	Width (mm)	Depth (mm)
795	440	250
CONNECTIONS		
GAS	DOMESTIC	SYSTEM
G	RR	R M
3/4"	1/2"	3/4" 3/4"

N.B.: connection group (optional)

Key (Fig. 1-2):

- V - Electrical connection
- G - Gas supply
- RU - Storage tank unit return (optional)
- MU - Storage tank unit flow (optional)
- RR - System filling
- SC - Condensate drain (minimum internal diameter Ø 13 mm)
- R - System return
- M - System flow

1-2

1.3 MAIN DIMENSIONS RECESS KIT (OPTIONAL).

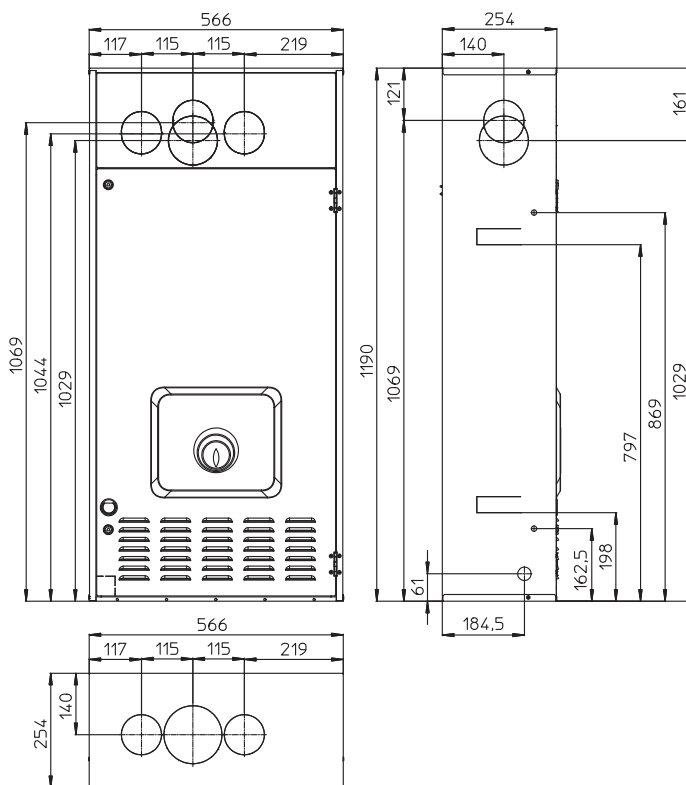

1-3

1.4 ANTI-FREEZE PROTECTION.

Minimum temperature -5°C. The boiler comes standard with an anti-freeze function that activates the pump and burner when the system water temperature in the boiler falls below 4°C. The anti-freeze function is only guaranteed if:

- the boiler is correctly connected to gas and electricity power supply circuits;
- the boiler is powered constantly;
- the boiler is not off ("off" mode);
- the boiler is not in no ignition block (Par. 2.6);
- the boiler essential components are not faulty.

In these conditions the boiler is protected against freezing to an environmental temperature of -5°C.

Minimum temperature -15°C. If the boiler is installed in a place where the temperature falls below -5°C and in the event there is no gas (or the boiler goes into ignition block), the appliance can freeze.

To prevent the risk of freezing follow the instructions below:

- protect the central heating circuit from freezing by introducing a top quality anti-freeze liquid into this circuit, which is not noxious to health. The instructions of the manufacturer of this liquid must be followed scrupulously regarding the percentage necessary with respect to the minimum temperature at which the system must be kept. An aqueous solution must be made with potential pollution class of water 2 on the basis of the Standards in force.

The materials used for the central heating circuit of Immergas boilers resist ethylene and propylene glycol based antifreeze liquids (if the mixtures are prepared perfectly).

For duration and possible disposal, follow the supplier's instructions.

- Protect the condensate drain trap and circuit board against freezing by using an accessory that is supplied on request (anti-freeze kit) comprising two electric heating elements, the relevant cables and a control thermostat (carefully read the installation instructions contained in the accessory kit pack).

Boiler anti-freeze protection is thus ensured only if:

- the boiler is correctly connected to gas and electricity power supply circuits and powered;
- the anti-freezing kit components are efficient.

In these conditions the boiler is protected against freezing to temperature of -15°C.

The warranty does not cover damage due to interruption of the electrical power supply and failure to comply with that stated above.

N.B.: if the boiler is installed in places where the temperature falls below 0°C the domestic water and heating attachment pipes must be insulated.

INSTALLER

USER

TECHNICIAN

1.5 ATTACHMENTS.

Gas connection (Appliance category II_{2H3B/P}).

Our boilers are designed to operate with methane gas (G20) and LPG. Supply pipes must be the same as or larger than the 3/4" G boiler fitting. Before connecting the gas line, carefully clean inside all the fuel feed system pipes to remove any residue that could impair boiler efficiency. Also make sure the gas corresponds to that for which the boiler is prepared (see boiler data-plate). If different, the appliance must be converted for operation with the other type of gas (see converting appliance for other gas types). The dynamic gas supply (methane or LPG) pressure must also be checked according to the type used in the boiler, as insufficient levels can reduce generator output and cause malfunctions.

Ensure correct gas cock connection. The gas supply pipe must be suitably dimensioned according to current regulations in order to guarantee correct gas flow to the burner even in conditions of maximum generator output and to guarantee appliance efficiency (technical specifications). The coupling system must conform to standards.

Fuel gas quality. The appliance has been designed to operate with gas free of impurities; otherwise it is advisable to fit special filters upstream from the appliance to restore the purity of the gas.

Storage tanks (in case of supply from LPG depot).

- New LPG storage tanks may contain residual inert gases (nitrogen) that degrade the mixture delivered to the appliance causing functioning anomalies.
- Due to the composition of the LPG mixture, layering of the mixture components may occur during the period of storage in the tanks. This can cause a variation in the heating power of the mixture delivered to the appliance, with subsequent change in its performance.

Hydraulic connection

Important: In order not to void the warranty before making the boiler connections, carefully clean the heating system (pipes, radiators, etc.) with special pickling or de-scaling products to remove any deposits that could compromise correct boiler operation.

In compliance with Standards in force it is mandatory to treat the water in the heating system chemically, in compliance with the indications of the decree, in order to protect the system and appliance from deposits of lime scale.

Water connections must be made in a rational way using the couplings on the boiler template. The boiler safety valve outlet must be connected to a draining funnel. Otherwise, the manufacturer declines any responsibility in case of flooding if the drain valve cuts in.

Important: to preserve the duration of appliance efficiency features, in the presence of water whose features can lead to the deposit of lime scale, installation of the "polyphosphate dispenser" kit is recommended. On the basis of the Standards in force, it is mandatory to treat the supply water with temporary water hardness over or equal to 25 French degrees in the central heating circuit and over than or equal to 15 French degrees for DHW, using conditioning chemicals for powers ≤ 100 kW or with softeners for powers > 100 kW

Condensate drain. To drain the condensate produced by the appliance, it is necessary to connect to the drainage system by means of acid condensate resistant pipes having an internal diameter of at least 13 mm. The system connecting the appliance to the drainage system must be carried out in such a way as to prevent freezing of the liquid contained in it. Before appliance start-up, ensure that the condensate can be correctly removed. Also, comply with national and local regulations on discharging waste waters.

Electrical connection: The "Victrix X 12-24 2I" boiler has an IPX4D protection rating for the entire appliance. Electrical safety of the appliance is reached only when it is correctly connected to an efficient earthing system as specified by current safety standards.

Important: Immergas S.p.A. declines any responsibility for damage or physical injury caused by failure to connect the boiler to an efficient earth system or failure to comply with the reference standards.

Also ensure that the electrical installation corresponds to maximum absorbed power specifications as shown on the boiler data-plate. Boilers are supplied complete with an "X" type power cable without plug. The power supply cable must be connected to a 230V $\pm 10\%$ / 50Hz mains supply respecting L-N polarity and earth connection . This network must also have an omnipolar circuit breaker with class III over-voltage category. When replacing the power supply cable, contact a qualified technician (e.g. the Immergas After-Sales Technical Assistance Service). The power cable must be laid as shown (Fig. 1-5).

In the event of mains fuse replacement on the P.C.B., use a 3.15A quick-blow fuse. For the main power supply to the appliance, never use adapters, multiple sockets or extension leads.

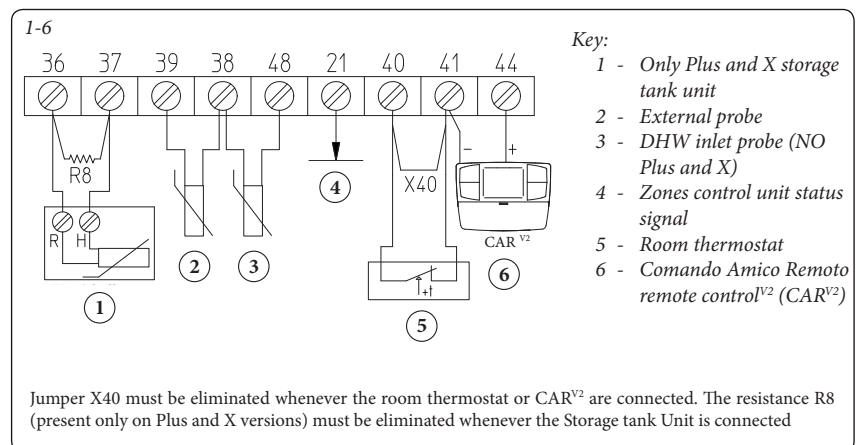
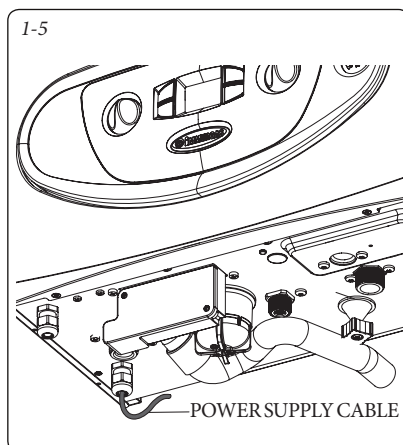

1.6 REMOTE CONTROLS AND ROOM CHRONO-THERMOSTATS (OPTIONAL).

The boiler is prepared for the application of room chrono-thermostats or remote controls, which are available as optional kits.

All Immergas chrono-thermostats are connected with 2 wires only. Carefully read the user and assembly instructions contained in the accessory kit.

- On/Off digital chrono-thermostat (Fig. 1-7). The chrono-thermostat allows:
 - to set two room temperature values: one for day (comfort temperature) and one for night (lower temperature);
 - to set up to four on/off differential weekly programs;
 - selecting the required function mode from the various possible alternatives:
- permanent operation in comfort temp;
- permanent operation in lower temp;
- permanent operation in adjustable anti-freeze temp.

The chrono-thermostat is powered by two 1.5V LR 6 type alkaline batteries.

- Comando Amico Remoto Remote Control Device ^{v2} CAR^{v2} (Fig. 1-8) with climate chrono-thermostat function. In addition to the functions described in the previous point, the CAR^{v2} panel enables the user to control all the important information regarding operation of the appliance and the heating system with the opportunity of easily intervening on the previously set parameters without having to go to the place where the appliance is installed. The Comando Amico Remoto ^{v2} Remote Control panel is provided with self-diagnosis to display any boiler operating anomalies. The climate chrono-thermostat incorporated into the remote panel enables the system flow temperature to be adjusted to the actual needs of the room being heated, in order to obtain the desired room temperature with extreme precision and therefore with evident saving in running costs. It also allows to display the effective room temperature and the external temperature (if external probe is present).

The chrono-thermostat is fed directly by the boiler by means of the same 2 wires used for the transmission of data between boiler and chrono-thermostat.

Important: if the system is divided into zones using the relevant kit, the CAR^{v2} must be used with its climate thermostat function disabled, i.e. it must be set to On/Off mode.

CAR^{v2} or chrono-thermostat On/Off electric connection (Optional). *The operations described below must be performed after having removed the voltage from the appliance.* The eventual On/Off environment chrono-thermostat must be connected to clamps 40 and 41 eliminating jumper X40 (Fig. 3-2). Make sure that the On/Off thermostat contact is of the “clean” type, i.e. independent of the mains supply, otherwise the P.C.B. would be damaged. Any CAR^{v2} must be connected by means of terminals + and - to clamps 41 and 44 on the P.C.B. (in boiler), eliminating jumper X40 and respecting polarity (Fig. 3-2). Connection with the wrong polarity prevents functioning, but without damaging the CAR^{v2}. The boiler can only be connected to one remote control.

Important: If the CAR^{v2} remote control is used, arrange two separate lines in compliance with current regulations regarding electrical systems. No boiler pipes must ever be used to earth the electric system or telephone lines. Ensure elimination of this risk before making the boiler electrical connections.

Installation with system operating at direct low temperature. The boiler can directly feed a low temperature system by acting on parameters “S5” and “S6” (par. 3.8). In this situation it is good practice to insert a relevant safety kit (optional) made up from a thermostat (with adjustable temperature). The thermostat must be positioned on the system flow pipe.

1.7 EXTERNAL PROBE (OPTIONAL).

The boiler is prepared for the application of the external probe (Fig. 1-9), which is available as an optional kit. Refer to the relative instruction sheet for positioning of the external probe.

The probe can be connected directly to the boiler electrical system and allows the max. system flow temperature to be automatically decreased when the external temperature increases, in order to adjust the heat supplied to the system according to the change in external temperature. The external probe always operates when connected, regardless of the presence or type of room chrono-thermostat used and can work in combination with Immergas chrono-thermostats. The correlation between system flow temperature and external temperature is determined by the position of the central heating selector switch on the boiler control panel (or on the CAR^{v2} control panel if connected to the boiler) according to the curves shown in the diagram (Fig. 1-10). The electric connection of the external probe must be made on clamps 38 and 39 on the terminal board positioned under the sealed chamber (Fig. 3-2).

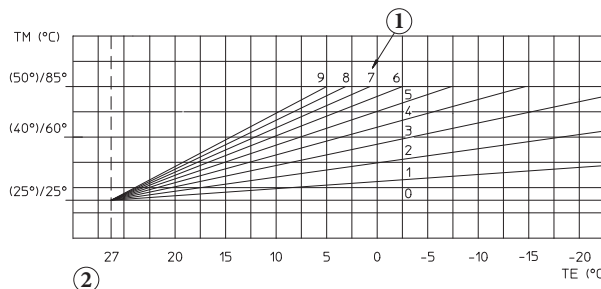
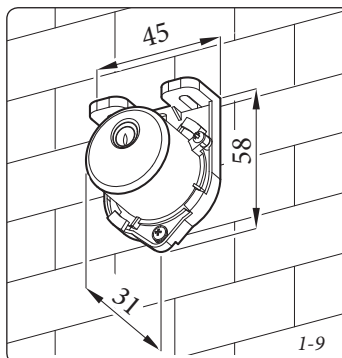
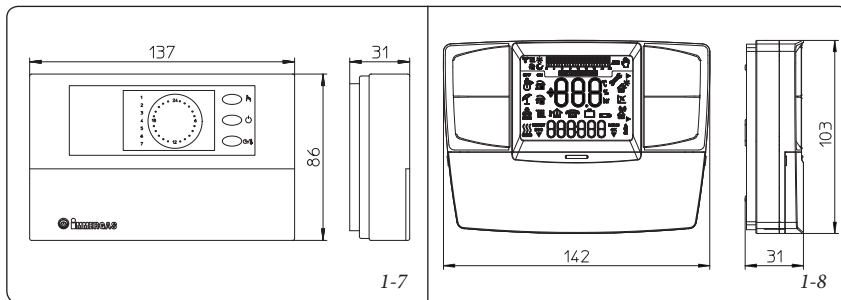

Key:
 1 - Position of the central heating temperature user adjustment
 2 - In brackets, temperature value with 25°/50° range
 TM - Flow Temperature (°C)
 TE - External Temperature (°C)

1-10

1.8 IMMERGAS FLUE SYSTEMS.

Immergas supplies various solutions separately from the boiler regarding the installation of air intake terminals and flue exhaust; fundamental for boiler operation.

Important: the boiler must be installed exclusively with an original Immergas "Green Range" air intake and flue gas extraction system in plastic, as envisioned by Standards in force.

The plastic pipes cannot be installed outdoors, for tracts longer than 40 cm, without suitable protection from UV rays and other atmospheric agents.

This system can be identified by an identification mark and special distinctive marking bearing the note: "only for condensing boilers".

- Resistance factors and equivalent lengths. Each flue extraction system component has a *Resistance Factor* based on experimental tests and specified in the table below. The resistance factor for individual components is independent from the type of boiler on which it is installed or the actual dimensions. It is, however, conditioned by the temperature of the fluids that pass through the pipe and therefore varies according to applications for air intake or flue exhaust. Each individual component has a resistance corresponding to a certain length in metres of pipe of the same diameter; the so-called *equivalent length*, obtained from the ratio between the relative Resistance Factors. *All boilers have an experimentally obtainable maximum Resistance Factor equal to 100.* The maximum Resistance Factor allowed corresponds to the resistance encountered with the maximum allowed pipe length for each type of Terminal Kit. This information enables calculations to verify the possibility of various configurations of flue extraction systems.

Positioning of the gaskets (black) for "green range" flue extraction systems. Position the gasket correctly (for bends and extensions) (Fig. 1-11):

- gasket (A) with notches, to use for bends;
- gasket (B) without notches, to use for extensions;

N.B.: if component lubrication (already carried out by the manufacturer) is not sufficient, remove the residual lubricant using a dry cloth, then to ease fitting spread the elements with common or industrial talc.

1.9 OUTDOOR INSTALLATION IN PARTIALLY PROTECTED AREA.

N.B.: a partially protected area is one in which the appliance is not exposed to the direct action of the weather (rain, snow, hail, etc.).

- **Configuration type B, open chamber and forced draught.**

Using the relevant cover kit direct air intake is possible (Fig. 1-12) and combustion products are exhausted into a single flue or directly to the outside. In this configuration it is possible to install the boiler in a partially protected place. In this configuration the boiler is classified as type B₂₃.

With this configuration:

- air intake takes place directly from the environment in which the appliance is installed (external);
- the flue exhaust must be connected to its own individual flue or channelled directly into the external atmosphere.

The technical regulations in force must be respected.

- **Cover kit assembly (Fig. 1-13).** Remove the two plugs and the gaskets present from the two lateral holes with respect to the central one. Now cover the right intake hole using the relevant plate, fixing it onto the left side using the two previously-removed screws. Install the Ø 80 outlet flange on the central hole of the boiler, taking care to insert the gasket supplied with the kit and tighten by means of the screws provided. Install the upper cover, fixing it using the 4 screws present in the kit, positioning the relevant gaskets. Engage the 90° Ø 80 bend with the male end (smooth) in the female end (with lip seal) of the Ø 80 flange unit until it stops. Introduce the gasket, making it run along the bend. Fix it using the sheet steel plate and tighten by means of the straps present in the kit, making sure to block the 4 gasket flaps. Fit the male end (smooth) of the exhaust terminal into the female end of the bend 90° Ø 80, making sure that the relevant wall sealing plate is already fitted; this will ensure hold and joining of the elements making up the kit.

Max. length of exhaust duct. The flue pipe (vertical or horizontal) can be *extended to a max. length of 30 straight metres.*

- **Coupling of extension pipes.** To install push-fitting extensions with other elements of the flue extraction elements assembly, proceed as follows: Couple the pipe or elbow with the male side (smooth) in the female side (with lip seal) to the end stop on the previously installed element. This will ensure sealing efficiency of the coupling.

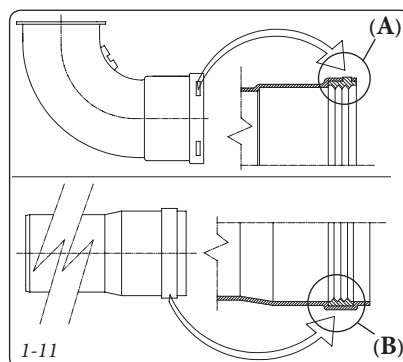

Example of installation with direct vertical terminal in partially protected location. When the vertical terminal for direct discharge of combustion products is used, a minimum gap of 300 mm must be left between the terminal and the balcony above. The height X+Y+Z+W evaluated with respect to the balcony above, must be equal to or more than 2000 mm. (Fig. 1-15). The term W must only be considered if the balcony above has closed balustrade (W=0 if the balustrade is open).

- **Configuration without cover kit in a partially protected location (type C boiler)**

By leaving the side plugs fitted it is possible to install the appliance externally without the cover kit. Installation takes place using the Ø60/100 concentric intake/ exhaust kits. Refer to the paragraph relative to indoor installation. In this configuration the upper cover kit guarantees additional protection for the boiler. It is recommended but not compulsory.

1.10 OUTDOOR INSTALLATION USING RECESS FRAME (WITH DIRECT AIR INTAKE)

For this configuration, use the appropriate spacers (included in the recess frame kit) and place them under the side plugs of the sealed chamber.

Air intake takes place directly from the external environment (the recessed frame is thus ventilated) and flue exhaust in single flue or directly outdoors.

The boiler in this configuration, following mounting instructions stated below, is classed as type B

In this configuration, the flue exhaust must be connected to its own individual flue or channelled directly into the external atmosphere. The technical regulations in force must be respected.

Max. length of exhaust duct. The flue pipe (vertical or horizontal) can be extended to a max. length of 30 straight metres.

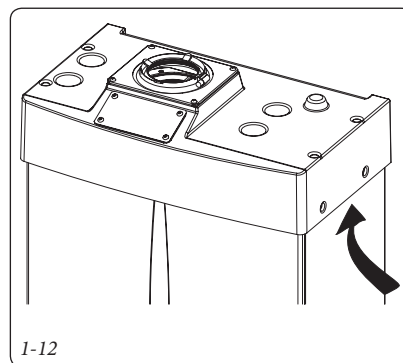

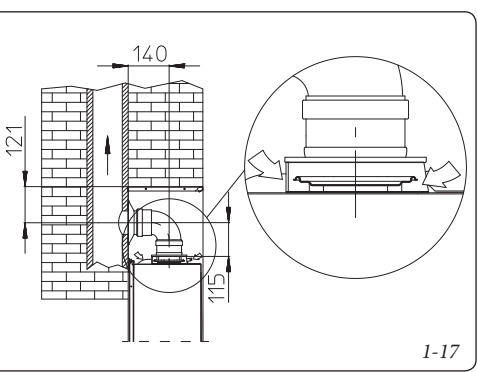
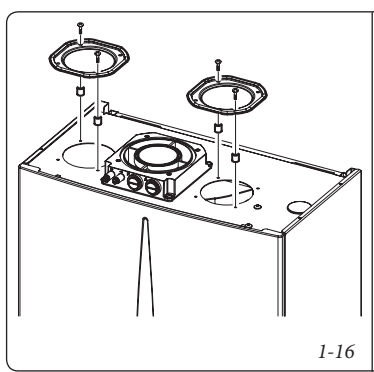
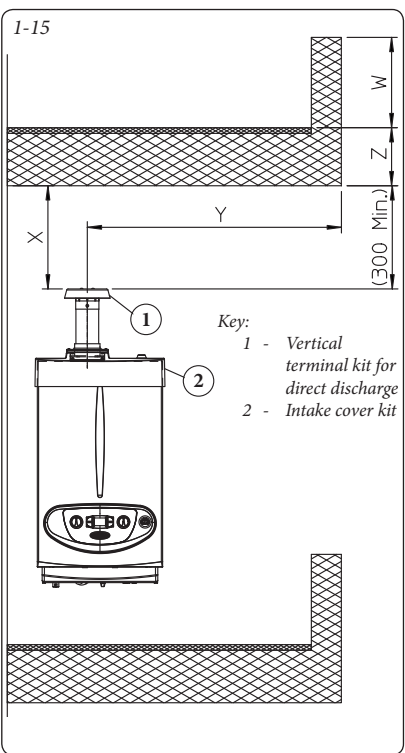
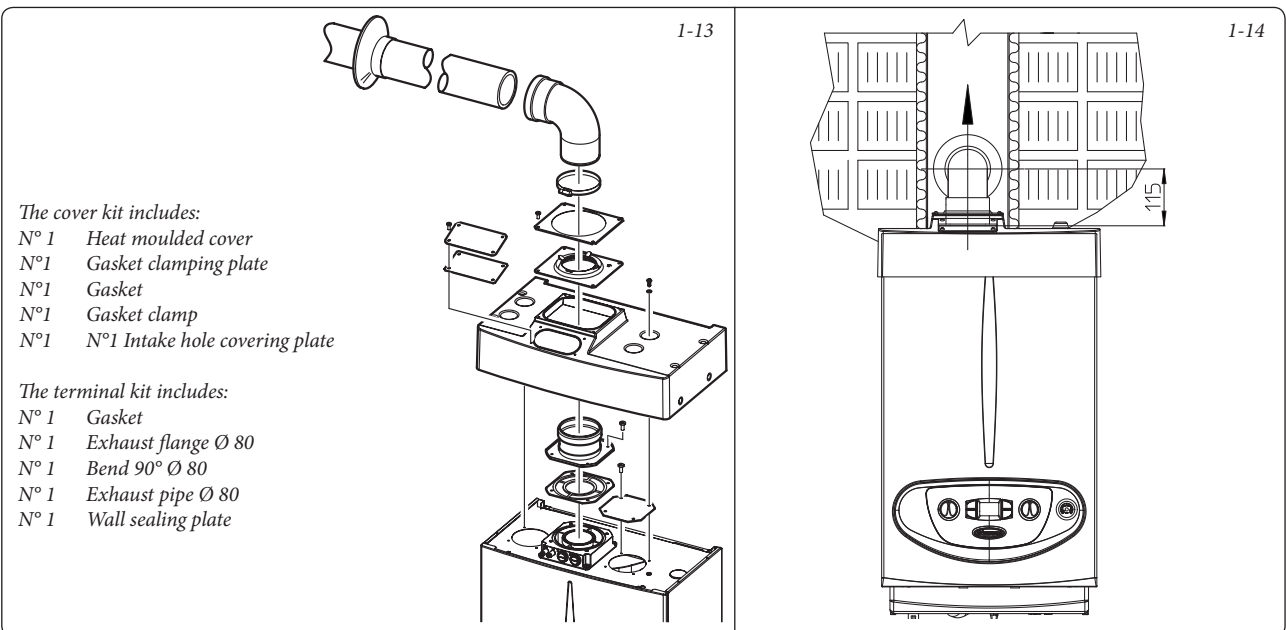







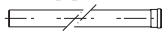
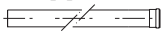
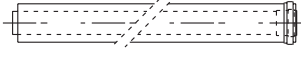

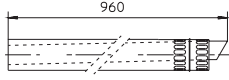

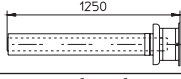

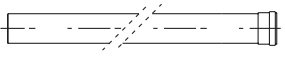
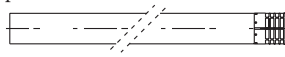
Spacer installation. For installation with direct air intake, type B₂₃, 4 spacers (present in the recess frame kit) should be inserted between the boiler and the two plugs of the sealed chamber so that combustion agent air can reach the boiler directly from the place of installation (Fig. 1-16 and 1-17).

- Coupling of extension pipes. To install push-fitting extensions with other elements of the flue extraction elements assembly, proceed as follows: Couple the pipe or elbow with the male side (smooth) in the female side (with lip seal) to the end stop on the previously installed element. This will ensure sealing efficiency of the coupling.

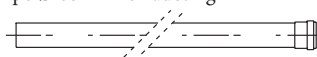
Tables of Resistance Factors and Equivalent Lengths.

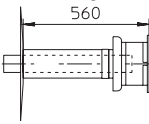
DUCT TYPE	Resistance Factor (R)	Equivalent length in m of concentric pipe \varnothing 60/100 	Equivalent length in metres of pipe \varnothing 80 	Equivalent length in metres of pipe \varnothing 60 
Concentric pipe \varnothing 60/100 m 1 	Intake and Exhaust 6.4	m 1	Intake m 7.3 Exhaust m 5.3	Exhaust m 1.9
Concentric bend 90° \varnothing 60/100 	Intake and Exhaust 8.2	m 1.3	Intake m 9.4 Exhaust m 6.8	Exhaust m 2.5
Concentric bend 45° \varnothing 60/100 	Intake and Exhaust 6.4	m 1	Intake m 7.3 Exhaust m 5.3	Exhaust m 1.9
Terminal complete with concentric horizontal intake-exhaust \varnothing 60/100 	Intake and Exhaust 15	m 2.3	Intake m 17.2 Exhaust m 12.5	Exhaust m 4.5
Concentric horizontal intake- exhaust terminal \varnothing 60/100 	Intake and Exhaust 10	m 1.5	Intake m 11.5 Exhaust m 8.3	Exhaust m 3.0
Terminal complete with concentric vertical intake-exhaust \varnothing 60/100 	Intake and Exhaust 16.3	m 2.5	Intake m 18.7 Exhaust m 13.6	Exhaust m 4.9
Concentric vertical intake-exhaust terminal \varnothing 60/100 	Intake and Exhaust 9	m 1.4	Intake m 10.3 Exhaust m 7.5	Exhaust m 2.7
Pipe \varnothing 80, 1 m 	Intake 0.87 Exhaust 1.2	m 0.1 m 0.2	Intake m 1.0 Exhaust m 1.0	Exhaust m 0.4
Complete intake terminal \varnothing 80, 1 m 	Intake 3	m 0.5	Intake m 3.4	Exhaust m 0.9
Intake terminal \varnothing 80 Exhaust terminal \varnothing 80 	Intake 2.2 Exhaust 1.9	m 0.35 m 0.3	Intake m 2.5 Exhaust m 1.6	Exhaust m 0.6
Bend 90° \varnothing 80 	Intake 1.9 Exhaust 2.6	m 0.3 m 0.4	Intake m 2.2 Exhaust m 2.1	Exhaust m 0.8
Bend 45° \varnothing 80 	Intake 1.2 Exhaust 1.6	m 0.2 m 0.25	Intake m 1.4 Exhaust m 1.3	Exhaust m 0.5
Pipe \varnothing 60 m 1 for ducting 	Exhaust 3.3	m 0.5	Intake 3.8 Exhaust 2.7	Exhaust m 1.0
Bend 90° \varnothing 60 for ducting 	Exhaust 3.5	m 0.55	Intake 4.0 Exhaust 2.9	Exhaust m 1.1
Reduction \varnothing 80/60 	Intake and Exhaust 2.6	m 0.4	Intake m 3.0 Exhaust m 2.1	Exhaust m 0.8
Terminal complete with exhaust vertical \varnothing 60 for ducting 	Exhaust 12.2	m 1.9	Intake m 14 Exhaust m 10.1	Exhaust m 3.7

1.11 INDOOR INSTALLATION.

- **Type C configuration, sealed chamber and fan assisted.**

Horizontal intake kits - exhaust Ø 60/100.

Kit assembly (Fig. 1-18): install the bend with flange (2) on the central hole of the boiler, positioning the gasket (1) (*which does not require lubrication*). Position it with the circular projections downwards in contact with the boiler flange and tighten using the screws preset in the kit. Fit the Ø 60/100 (3) concentric terminal pipe with the male end (smooth) to the female end of the bend (2) up to the stop; making sure that the internal and external wall sealing plate have been fitted, this will ensure sealing and joining of the elements making up the kit.

N.B.: for correct functioning of the system the terminal with grid must be installed correctly ensuring that, the "high" indication present on the terminal is respected on installation.

- Coupling extension pipes and concentric elbows Ø 60/100. To push-fit extensions with other elements of the flue extraction elements, operate as follows Install the concentric pipe or elbow with the male side (smooth) on the female section (with lip seal) to the end stop on the previously installed element. This will ensure sealing and joining of the elements correctly.

The kit Ø 60/100 can be installed with the rear, right side, left side or front outlet.

- Extensions for horizontal kit (Fig. 1-19). The horizontal intake-exhaust kit Ø 60/100 can be extended up to a *max. horizontal distance of 12.9 m* including the terminal with grid and excluding the concentric bend leaving the boiler. This configuration corresponds to a resistance factor of 100. In these cases the special extensions must be requested.

N.B.: when installing the pipes, a section clamp with pin must be installed every 3 metres.

- External grill. **N.B.:** for safety purposes, do not even temporarily obstruct the boiler intake-exhaust terminal.

Vertical kit with aluminium tile Ø 60/100. Kit assembly (Fig. 1-20): Install the concentric flange (2) on the central hole of the boiler, positioning the gasket (1) (*which does not require lubrication*) with the circular projections downwards in contact with the boiler flange and tighten using the screws present in the kit.

Imitation aluminium tile installation: replace the tile with the aluminium sheet (4), shaping it to ensure that rainwater runs off. Position the fixed half-shell (6) and insert the intake-exhaust pipe (5). Fit the Ø 60/100 (3) concentric terminal pipe with the male end (5) (smooth) into the flange (2) up to the stop; making sure that the wall sealing plate has been fitted (3), this will ensure sealing and joining of the elements making up the kit.

Note: when the boiler is installed in areas where very rigid temperatures can be reached, a special anti-freeze kit is available that can be installed as an alternative to the standard kit.

- Coupling extension pipes and concentric elbows. To install push-fitting extensions with other elements of the flue extraction elements assembly, proceed as follows: Install the concentric pipe or elbow with the male side (smooth) on the female section (with lip seal) to the end stop on the previously installed element in order to ensure sealing efficiency of the coupling.

Important: if the exhaust terminal and/or extension concentric pipe needs shortening, consider that the internal duct must always protrude by 5 mm with respect to the external duct.

This specific terminal enables flue exhaust and air intake, necessary for combustion, in a vertical direction.

N.B.: The vertical kit Ø 60/100 with aluminium tile enables installation on terraces and roofs with maximum slope of 45% (25°) and the height between the terminal cap and half-shell (374 mm) must always be respected. The vertical kit with this configuration can be extended up to *maximum of 14.4 straight vertical m*, including the terminal. This configuration corresponds to a resistance factor of 100. In this case the special extensions must be requested.

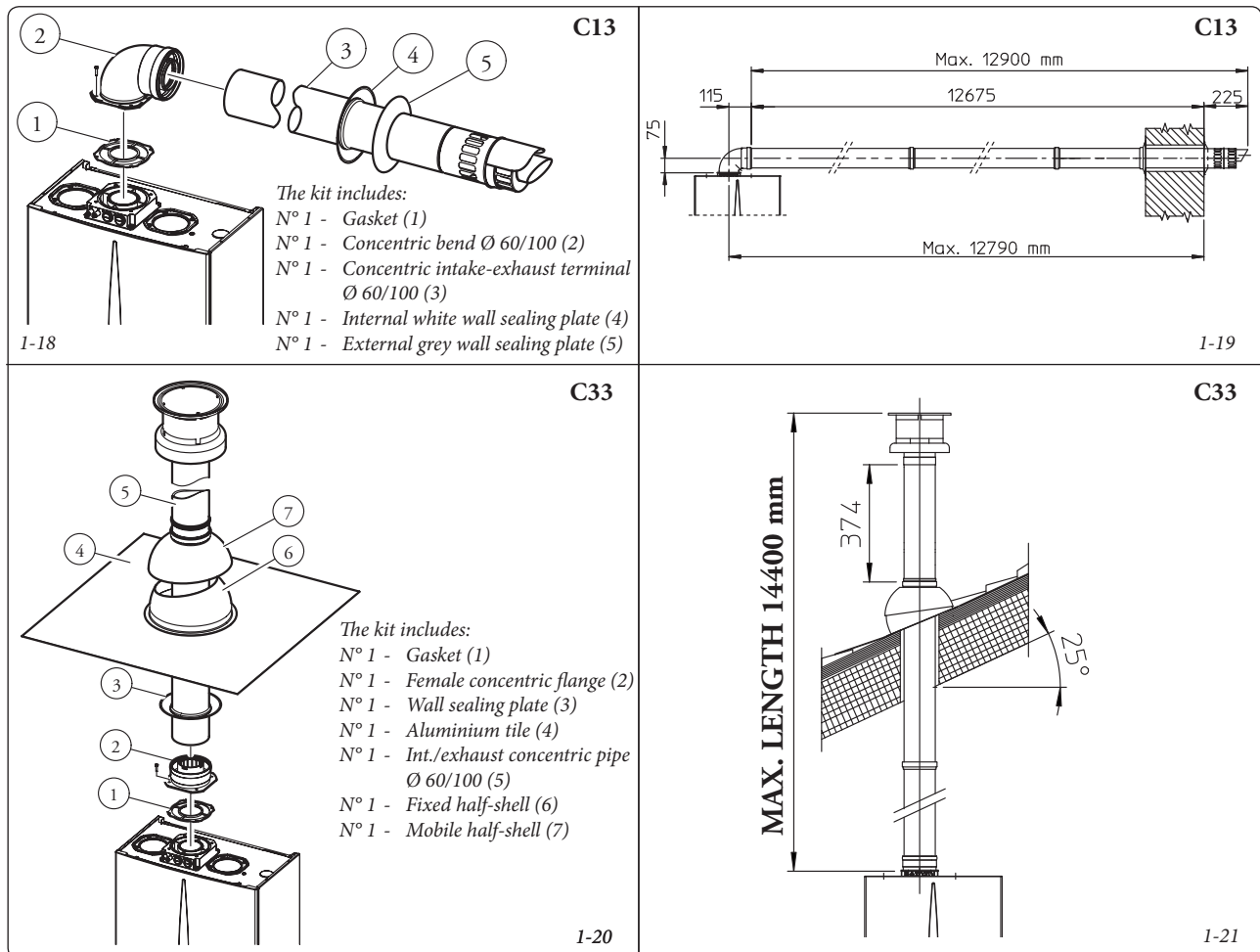

Separator kit Ø 80/80. The Ø 80/80 separator kit, allows separation of the exhaust flues and air intake pipes according to the diagram shown in the figure. Combustion products are expelled from pipe (S) (in plastic, so as to resist acid condensate). Air is taken in through duct (A) for combustion (this is also in plastic). The intake pipe (A) can be installed either on the right or left hand side of the central exhaust pipe (S). Both ducts can be routed in any direction.

- Kit assembly (Fig. 1-23): install the flange (4) on the central hole of the boiler, positioning the gasket (1) (*which does not require lubrication*) positioning it with the circular projections downwards in contact with the boiler flange and tighten using the hex screws with flat end present in the kit. Remove the flat flange present in the lateral hole with respect to the central one (according to needs) and replace it with the flange (3), positioning the gasket (2) already present in the boiler and tighten using the supplied self-threading screws. Fit the male end (smooth) to the bends (5) in the female end of the flanges (3 and 4). Fit the intake terminal (6) with the male section (smooth) in the female section of the bend (5) up to the stop, ensuring that the internal and external wall sealing plates are fitted. Fit the exhaust pipe (9) with the male end (smooth) to the female end of the bend (5) up to the stop; making sure that the internal wall sealing plate has been fitted, this will ensure sealing and joining of the elements making up the kit.

- Coupling of extension pipes and elbows. To install push-fitting extensions with other elements of the flue extraction elements assembly, proceed as follows: Install the pipe or elbow with the male side (smooth) on the female section (with lip seal) to the end stop on the previously installed element. This will ensure sealing and joining of the elements correctly.
- Installation clearance (Fig. 1-24). The minimum installation clearance measurements of the Ø 80/80 separator terminal kit have been stated in some limit conditions.
- Extensions for Ø 80/80 separator kit. The maximum vertical straight length (without bends) that can be used for Ø 80 intake and exhaust pipes is 41 metres, independently to whether they are used for intake or exhaust. The maximum horizontal straight length (with bend in suction and in exhaust) that can be used for Ø 80 intake and exhaust pipes is 36 metres independently to whether they are used for intake or exhaust.

N.B.: to favour the removal of possible condensate forming in the exhaust pipe, tilt the pipes towards the boilers with a min. slope of 1.5%. (Fig. 1-25). When installing the Ø 80 ducts, a section clamp with pin must be installed every 3 metres.

- Configuration type B₂₃ open chamber and forced draught.**

The appliance can be installed inside buildings in B₂₃ mode; in this eventuality, all technical rules and national and local regulations in force, must be complied with.

- Type B open chamber boilers must not be installed in places where commercial, artisan or industrial activities take place, which use products that may develop volatile vapours or substances (e.g. acid vapours, glues, paints, solvents, combustibles, etc.), as well as dusts (e.g. dust deriving from the working of wood, coal fines, cement, etc.), which may be damaging for the components of the appliance and jeopardise functioning.
- in type B₂₃ configuration, the boilers must not be installed in bedrooms, bathrooms or in bed-sitters.
- The installation of appliances in B₂₃ configuration is only recommended outdoors (in a partially protected place) or in places that are not lived in and which are permanently ventilated.

1.12 DUCTING OF FLUE TECHNICAL SLOTS.

Ducting is an operation through which by the introduction of one or more relevant pipes, a system is realised for the evacuation of the combustion products of a gas appliance made up from the coupling of an existing or new ducting pipe with a chimney, flue or technical slot (also in new buildings) (Fig. 1-24). Ducting requires the use of ducts declared to be suitable for the purpose by the manufacturer, following the installation and user instructions, provided by the manufacturer and the requirements of the standards.

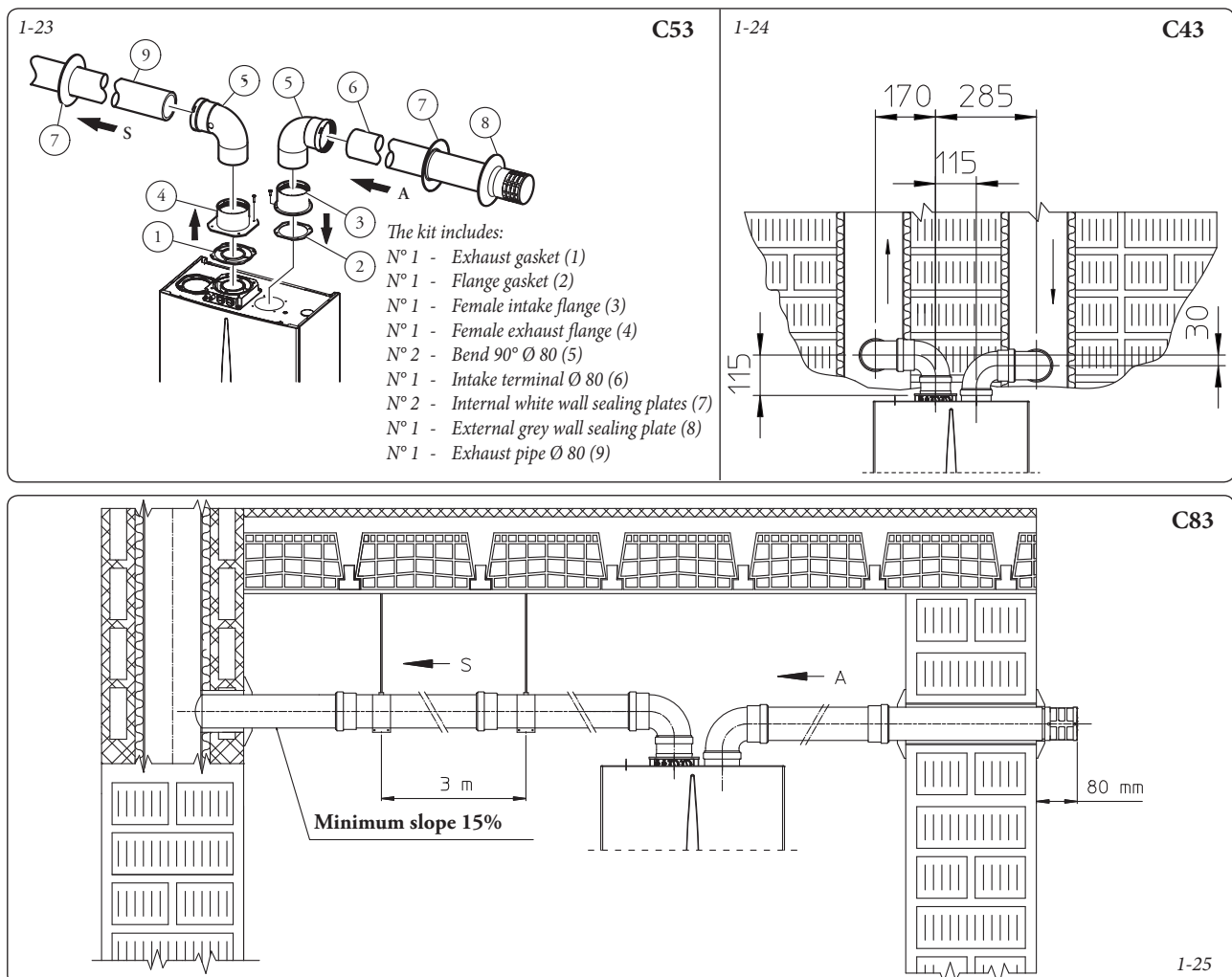

Immergas ducting system. The Ø60 rigid and Ø80 flexible "Green Range" ducting systems must only be used for domestic use and with Immergas condensing boilers.

In any case, ducting operations must respect the provisions contained in the standard and in current technical regulations; in particular, the declaration of conformity must be compiled at the end of work and on commissioning of the ducted system. The instructions in the project or technical report must likewise be followed, in cases provided for by the standard and current technical regulations. The system or components of the system have a technical life complying with current standards, provided that:

- it is used in average atmospheric and environmental conditions, according to current regulations and in particular, by the Standard (absence of combustion products, dusts or gases that can alter the normal thermophysical or chemical conditions; existence of temperatures coming within the standard range of daily variation, etc.).
- Installation and maintenance must be performed according to the indications supplied by the manufacturer and in compliance with the provisions in force.
- The max. possible length of the Ø 60 flexible ducting vertical section is equal to 22 m. This length is obtained considering the complete Ø 80 exhaust terminal, 1m of Ø 80 pipe in exhaust, two 90° Ø 80 bends at boiler outlet.
- The max. possible length of the Ø 80 flexible ducting vertical section is equal to 30 m. This length is obtained considering the complete exhaust terminal, 1m of Ø 80 pipe in exhaust, two 90° Ø 80 bends at boiler outlet for connecting to the ducting system and two direction changes of the flexible tube inside the flue/technical slot.
- The max. possible length of the Ø 60 flexible ducting vertical section is equal to 30 m. This length is obtained considering the complete Ø 80 exhaust terminal, 1m of Ø 80 pipe in exhaust, two 90° Ø 80 bends at boiler outlet.

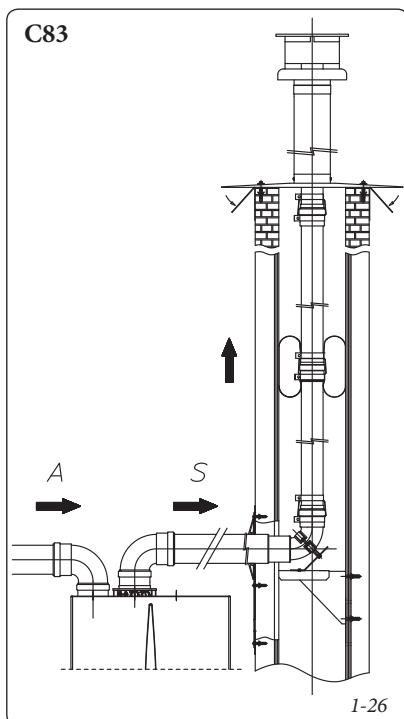

1.13 FLUE EXHAUST TO FLUE/CHIMNEY.

Flue exhaust does not necessarily have to be connected to a branched type traditional flue. The flue exhaust, for boiler only installed in C configuration, can be connected to a special LAS type multiple flue. The multiple flues and the combined flues must also only be connected to type C appliances of the same type (condensing), having nominal heat inputs that do not differ by more than 30% less with respect to the maximum that can be attached and powered by the same fuel. The thermo-fluid dynamic features (flue flow rate, % of carbon dioxide, % humidity etc...) of the appliances attached to the same multiple flues or combined flues, must not differ by more than 10% with respect to the average boiler attached. Multiple and combined flues must be specially designed according to the calculation method and requirements of the standards, by professionally qualified technical staff. Chimney or flue sections for connection of the exhaust pipe must comply with requisites of technical standards in force.

1.14 FLUES, CHIMNEYS AND CHIMNEY CAPS.

The flues, chimneys and chimney caps for the evacuation of combustion products must be in compliance with applicable standards.

Positioning the exhaust terminals. The exhaust terminals must:

- be installed on external perimeter walls of the building;
- be positioned according to the minimum distances specified in current technical standards.

Combustion products exhaust of natural or fan assisted appliances in open-top closed environments. In spaces closed on all sides with open tops (ventilation pits, courtyards etc.), direct flue exhaust is allowed for conventional or fan assisted draught gas appliances with a heating power range from 4 to 35 kW, provided the conditions as per the current technical standards are respected.

1.15 SYSTEM FILLING.

Once the boiler is connected, proceed with system filling via the filling valve (Fig. 1-28 and 2-2). Filling is performed at low speed and using the automatic vent functions to ensure release of air bubbles in the water via the boiler and heating system vents.

The boiler has a built-in automatic venting valve on the circulator. *Check if the cap is loose.* Open the radiator air vent valves.

Close radiator vent valves when only water escapes from them.

Close the filling valve when the boiler manometer indicates approx. 1.2 bar.

N.B.: vent the circulation pump by loosening the front cap and keeping the motor running. Retighten the cap after the operation

1.16 FILLING THE CONDENSATE TRAP.

On first lighting of the boiler combustion products may come out the condensate drain; after a few minutes' operation check that this no longer occurs. This means that the trap is filled with condensate to the correct level preventing the passage of combustion products.

1.17 GAS SYSTEM START-UP.

To start up the system, make reference to the Standard: This divides the systems and therefore the start-up operations into three categories: new systems, modified systems, re-activated systems.

In particular, for new gas systems:

- open windows and doors;
- avoid presence of sparks or naked flames;
- bleed all air from pipelines;
- check that the internal system is properly sealed according to specifications.

1.18 BOILER START UP (IGNITION).

For issue of the Declaration of Conformity provided for by Italian Law, the following must be performed for boiler start-up:

- check that the internal system is properly sealed according to specifications;
- ensure that the type of gas used corresponds to boiler settings;
- switch the boiler on and ensure correct ignition;
- make sure that the gas flow rate and relevant pressure values comply with those given in the manual (Par. 3.19);
- ensure that the safety device is engaged in the event of gas supply failure and check activation time;
- check activation of the master switch located upstream from the boiler and in the boiler;
- check that the concentric intake-exhaust terminal (if fitted) is not blocked.

The boiler must not be started up even if only one of the checks should be negative.

N.B.: The boiler preliminary check must be carried out by a qualified technician. The conventional boiler warranty is valid as of the date of testing. The test certificate and warranty is issued to the user.

1.19 CIRCULATION PUMP.

The “Victrix X 12-24 2I” series boilers are supplied with a built-in circulation pump with 3-position electric speed control. The boiler does not operate correctly with the circulation pump on first speed. To ensure optimal boiler operation, in the case of new systems (single pipe and module) it is recommended to use the pump at maximum speed. The circulation pump is already fitted with a capacitor.

Pump release. If, after a prolonged period of inactivity, the circulation pump is blocked, unscrew the front cap and turn the motor shaft using a screwdriver. Take great care during this operation to avoid damage to the motor.

By-pass regulation (part. 25 Fig. 1-28). If necessary, the by-pass can be regulated according to system requirements from a minimum (by-pass excluded) to a maximum (by-pass inserted) represented by the graphics (Fig. 1-27). Make the regulation using a flat head screwdriver, turn clockwise and insert the by-pass, anti-clockwise it is excluded.

Total head available to the system.

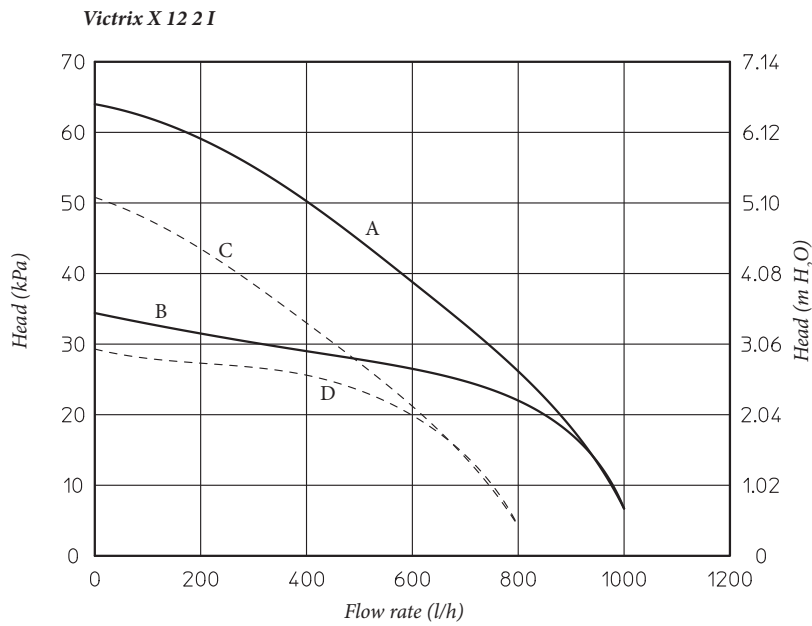

- A = Head available to the system at maximum speed with by-pass excluded.
- B = Head available to the system at maximum speed with by-pass inserted.
- C = Head available to the system at second speed with by-pass excluded.
- D = Head available to the system at second speed with by-pass inserted.

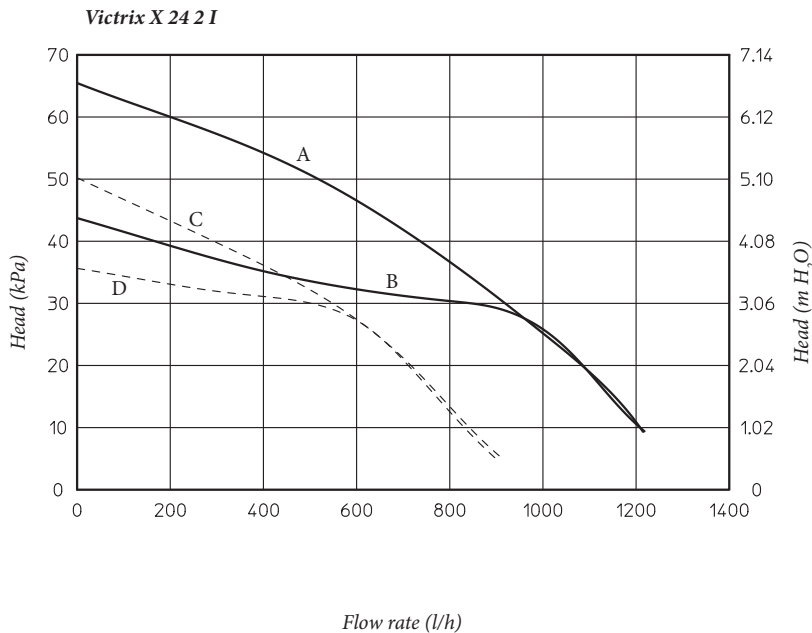

- A = Head available to the system at maximum speed with by-pass excluded.
- B = Head available to the system at maximum speed with by-pass inserted.
- C = Head available to the system at second speed with by-pass excluded.
- D = Head available to the system at second speed with by-pass inserted.

1.20 KITS AVAILABLE ON REQUEST.

- System cut-off valve kits with or without inspectionable filter (on request) The boiler is designed for installation of system cut-off cocks to be placed on flow and return pipes of the connection assembly. This kit is very useful for maintenance because it allows to empty just the boiler without having to empty the entire system. Moreover, the version with filter preserves the functioning characteristics of the boiler thanks to its inspectionable filter.
- System zone control unit kit (on request). If the central heating system is to be divided into several zones (**max. three**) in order to interlock them with separate adjustments and to keep water flow rate high for each zone, Immergas supplies zone system kits on request.
- External storage tank unit coupling kit (on request). If the production of DHW is required as well as room central heating, on request Immergas supplies a kit made up from an external cylinder unit and everything necessary for adaptation of the boiler
- Polyphosphate dispenser kit (on request). The polyphosphate dispenser reduces the formation of lime-scale and preserves the original heat exchange and domestic hot water production conditions. The boiler is prepared for application of the polyphosphate dispenser kit.
- Relay board (on request). The boiler is prepared for the installation of a relay card that allows to increase the features of the appliance and therefore functioning possibilities.
- Cover kit (on request). If installed outdoors in a partially protected place with direct air intake, it is compulsory to mount the appropriate top protection cover for the correct functioning of the boiler and to protect it from adverse weather conditions.
- Installation kit with recess frame. Using a suitable recess frame, it is possible to fit the boiler inside the wall, configuration type C, or with direct outdoor air intake, thanks to the ventilated recess frame.
- a) Attachment kit for wall installation.
- b) Attachment kit for recess boiler.
The kit includes pipes, fittings and cocks (including gas cock) for the connection of the boiler to the system and 4 spacers to be used under the side plugs of the sealed chamber (the plugs are recess type).

N.B.: for recess fitting, using the same kit (b), it is possible to carry out front installation or back installation exiting the recess frame.

The above-mentioned kits are supplied complete with instructions for assembly and use.

1.21 BOILER COMPONENTS.

INSTALLER

USER

TECHNICIAN

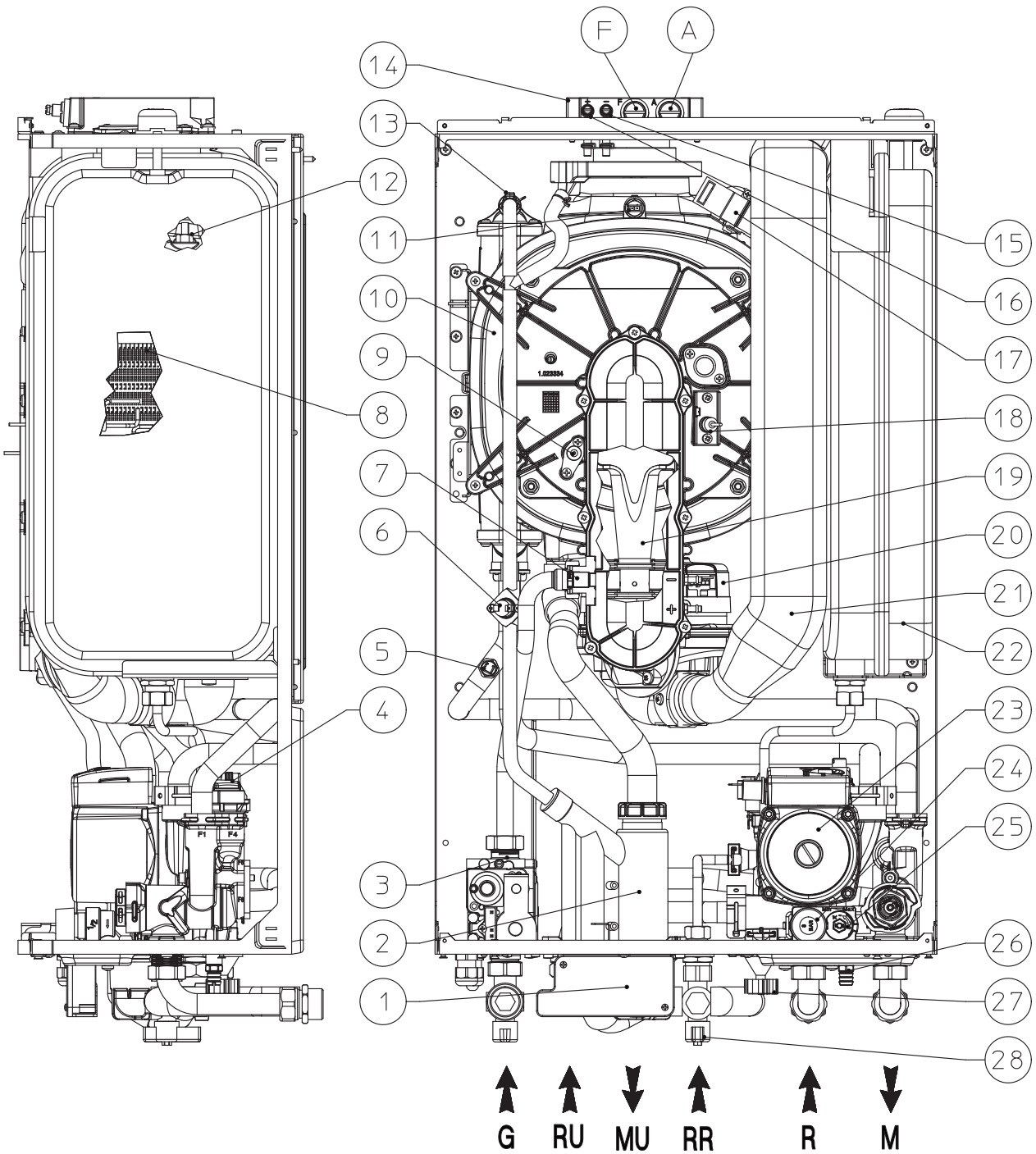

Key:

- 1 - Electric connection terminal board
(very low voltage)
- 2 - Condensate drain trap
- 3 - Gas valve
- 4 - Air vent valve
- 5 - Flow probe
- 6 - Safety thermostat
- 7 - Gas nozzle
- 8 - Burner
- 9 - Detection electrode
- 10 - Condensation module
- 11 - Flue probe
- 12 - Heat exchanger safety thermofuse
- 13 - Manual air vent valve
- 14 - Sample points (air A) - (flue gases F)

- 15 - Negative signal pressure point
- 16 - Positive signal pressure point
- 17 - Igniter
- 18 - Ignition electrode
- 19 - Venturi
- 20 - Fan
- 21 - Air intake pipe
- 22 - System expansion vessel
- 23 - Boiler pump
- 24 - 3 bar safety valve
- 25 - By-pass
- 26 - System draining valve
- 27 - System filling valve
- 28 - Filling cut-off valve

N.B.: connection group (optional)

2 INSTRUCTIONS FOR USE AND MAINTENANCE.

2.1 CLEANING AND MAINTENANCE.

Important: the heating systems must undergo periodical maintenance (regarding this, see the section dedicated to the technician, relative to “yearly control and maintenance of the appliance”) and regular checks of energy efficiency in compliance with national, regional or local provisions in force.

This ensures that the optimal safety, performance and operation characteristics of the boiler remain unchanged over time.

We recommend stipulating a yearly cleaning and maintenance contract with your zone technician.

2.2 GENERAL WARNINGS

Never expose the wall-mounted boiler to direct vapours from a cooking surface.

Use of the boiler by unskilled persons or children is strictly prohibited.

For safety purposes, check that the concentric air intake/flue exhaust terminal (if fitted), is not blocked.

If temporary shutdown of the boiler is required, proceed as follows:

- drain the heating system if anti-freeze is not used;
- shut-off all electrical, water and gas supplies.

In the case of work or maintenance to structures located in the vicinity of ducting or devices for flue extraction and relative accessories, switch off the appliance and on completion of operations ensure that a qualified technician checks efficiency of the ducting or other devices. Never clean the appliance or connected parts with easily flammable substances.

Never leave containers or flammable substances in the same environment as the appliance.

• **Important:** the use of components involving use of electrical power requires some fundamental rules to be observed:

- do not touch the appliance with wet or moist parts of the body; do not touch when barefoot;
- never pull electrical cables or leave the appliance exposed to atmospheric agents (rain, sunlight, etc.);

- the appliance power cable must not be replaced by the user;
- in the event of damage to the cable, switch off the appliance and contact exclusively qualified staff for replacement;
- if the appliance is not to be used for a certain period, disconnect the main power switch.

INSTALLER

USER

TECHNICIAN

2.3 CONTROL PANEL.

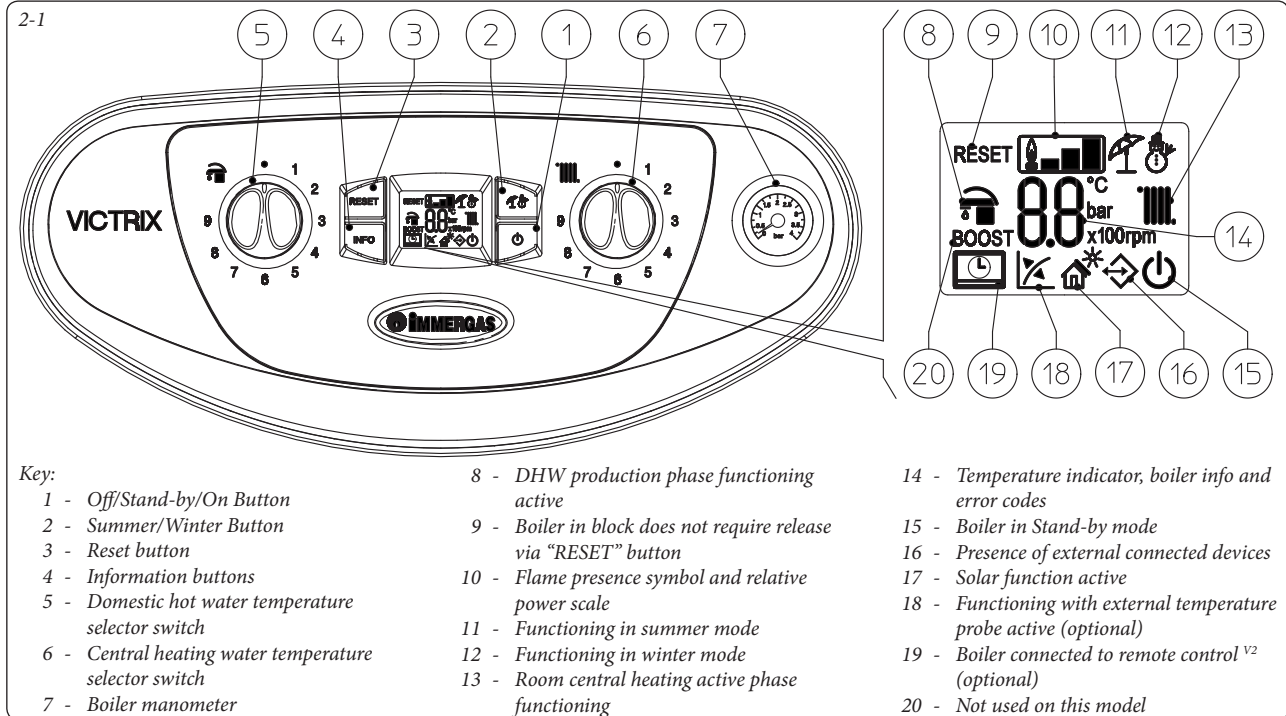

2.4 USING THE BOILER.

Important:

the Victrix X 12-24 21 boiler has been designed to operate as an appliance for room central heating only or, coupled to a specific optional kit, for central heating and the production of DHW. For this reason the boiler control panel has a knob to adjust the temperature of DHW, but its operation is only activated by the optional kits that also enable the production of DHW. Without the coupling to these specific kits, the functioning of this knob and all functions referring to DHW are inhibited, apart from the gas valve calibration phase.

Before ignition make sure the heating system is filled with water and that the manometer (7) indicates a pressure of 1 ÷ 1.2 bar.

- Open the gas cock upstream from the boiler.
- Press the button (1) until the display switches on. At this point, the boiler goes to the state previous to switch-off.
- If the boiler is in stand-by, press the button (1) again to activate it. If this is not the case, go to the next point.
- Press button (2) in sequence and take the boiler to summer (☀️) or winter (❄️) position.

• **Summer (☀️):** in this mode the boiler functions only to produce the DHW, the

temperature is set via the selector (5) and the relative temperature is shown on the display via the indicator (14).

• **Winter (❄️):** in this mode the boiler functions both for producing domestic hot water and heating the environment. The temperature of the DHW is always regulated via the selector (5), the heating temperature is regulated via selector (6) and the relative temperature is shown on the display via the indicator (14).



From this moment the boiler functions automatically. With no demand for heat (heating or domestic hot water production) the boiler goes to “standby” function, equivalent to the boiler being powered without presence of flame.

Each time the burner ignites, the relative flame present symbol is displayed (10) with relative power scale.

- **Operation with Comando Amico Remoto remote control v² (CAR^{v2}) (Optional).** If the CAR^{v2} is connected, the () symbol will appear on the display. The boiler regulation parameters can be set via the CAR^{v2} control panel and the reset button (3) remains active on the boiler control panel, along with the switch-off button (1) (“off” mode only) and the display where the functioning state is shown

Important: if the boiler is put into “off” mode, the “ERR>CM” connection error symbol will appear on the CAR^{v2}. The CAR^{v2} is however powered constantly so as not to lose memorised programs.

- **Solar functioning mode ().** This function is activated automatically if the boiler detects a probe on the DHW inlet (optional) or if the “Solar ignition delay” parameter is more than 0 seconds.

During a withdrawal, if the outlet water is hot enough, the boiler does not switch on, the DHW withdrawal symbol () appears on the display along with the flashing solar function symbol ().

When the water supplied by the solar system is at a temperature lower than that at which the boiler is set, the boiler switches on. At this point, the solar function symbol will stay on without flashing.

- **Functioning with optional external probe ().** In the case of a system with optional external probe, the boiler flow temperature for room central heating is managed by the external probe depending on the external temperature measured (Par. 1.6). The flow temperature can be modified by selecting the functioning curve via the selector switch (6) (or on the CAR^{v2} control panel, if connected to the boiler) selecting a value from “0 to 9”.

With external probe present, the relative symbol (18) will appear on the display. In the central heating phase, if the temperature of the water contained in the system is sufficient to heat the radiators, the boiler can only function with the activation of the pump.

- **“Stand-by” mode.** Press button (1) in succession until the () symbol appears. The boiler remains inactive from this moment and the anti-freeze function, pump anti-block function and 3-way and signalling of any anomalies is guaranteed.

N.B.: in these conditions the boiler is considered still powered.

- **“Off” mode.** By holding the button (1) down for 8 seconds, the display switches-off and the boiler is off completely. The safety functions are not guaranteed in this mode.

N.B.: in these conditions the boiler is considered still live even if there are no functions active.

- **“Automatic vent” mode.** Every time power is supplied to the boiler, the system automatic vent function is activated (duration 8 minutes). This function is displayed via countdown signalled by the indicator (14). During this period the DHW and CH functions are not active.

The “automatic vent” can be annulled by pressing the “reset” button (4).

- **Display functioning.** The display lights up during the use of the control panel, after 15 seconds inactivity, the brightness drops until just the active symbols are displayed. The lighting mode can be varied via parameter t3 in the circuit board customisation menu.

2.5 FAULT AND ANOMALY SIGNALS.

The Victrix 12 -24l boiler signals any anomalies using a code shown on the boiler display (14) according to the following table.

Anomaly signalled	Error code
No ignition block	01
Safety thermostat block (over-heating), flame control anomaly	02
Flue safety thermostat block	03
Contacts resistance block	04
Flow probe anomaly	05
Maximum N° of reset	08
Insufficient system pressure	10
Storage tank probe anomaly (optional)	12
Configuration error	15
Fan anomaly	16
Parasite flame block	20
Push button control panel anomaly	24
Block due to flue gas temperature gradient intervention	25
Insufficient circulation	27
Flue probe anomaly	29
Loss of remote control communication	31
IMG Bus communication loss	36
Low power supply voltage	37
Loss of flame signal	38
Block due to loss of continuous flame signal	43
Block for maximum time, partial gas valve opening	44
Low temperature safety thermostat (optional)	46
Burner power limitation	47

N.B.: on the Comando Amico Remoto^{v2} remote control (Optional), the error code corresponds to the previous list with the “ERR>” indication in front (E.g. code 01 CAR^{v2} code ERR>01).

Ignition block. The boiler ignites automatically with each demand for room central heating or hot water production. If this does not occur within the pre-established time, the boiler goes into no ignition block. To eliminate “no ignition block” the Reset button (3) must be pressed. On commissioning or after extended inactivity it may be necessary to eliminate the “no ignition block”. If this phenomenon occurs frequently, contact a qualified technician for assistance

(e.g. Immergas After-Sales Technical Assistance Service).

Safety thermostat block (over-heating), flame control anomaly. During regular operation, if a fault causes excessive overheating internally or an anomaly occurs in the flame control section, an overheating block is triggered in the boiler. To eliminate “overheating block” the Reset button (3) must be pressed. If this phenomenon occurs frequently, contact a qualified technician for assistance (e.g. Immergas After-Sales Technical Assistance Service).

Flue safety thermostat block. This occurs in the case of partial internal obstruction (due to the presence of lime scale or mud) or external blocking should occur (combustion residues) to the condensation module. To eliminate the “flue thermostat block” the Reset button (3) must be pressed. Call an authorised technician to remove the obstructions (e.g. Immergas After-sales Service).

Contacts resistance block. This occurs in the case of faults to the safety thermostat (over-temperature) or anomaly in the flame control. The boiler does not start and a technician must be called (e.g. Immergas After-Sales Service).

System flow probe anomaly. If the board detects an anomaly on the system NTC flow probe, the boiler will not start; contact a qualified technician for assistance (e.g. Immergas After-Sales Service).

Maximum N° of reset. To eliminate any anomaly, the Reset button (3) must be pressed. The Anomaly can be reset 5 times consecutively, after which the function is inhibited for at least one hour. One attempt is gained every hour for a maximum of 5 attempts.

Insufficient system pressure. Water pressure inside the central heating system that is sufficient to guarantee the correct functioning of the boiler is not detected. Check on the boiler manometer (7) that the system pressure is between 1÷1.2 bar and restore the correct pressure if necessary.

Storage tank probe anomaly (optional). If the board detects an anomaly on the storage tank probe, the boiler cannot produce DHW and signals an anomaly; if necessary contact a qualified technician for assistance (e.g. Immergas After-Sales Technical Assistance Service).

Configuration error. If the board detects an anomaly or incongruity on the electric wiring, the boiler will not start. If normal conditions are restored the boiler restarts without having to be reset. If this anomaly persists, contact a qualified technician for assistance (e.g. Immergas After-Sales Service).

Fan anomaly. This occurs if the fan has a mechanical or electrical fault. To eliminate the “fan anomaly” the Reset button (3) must be pressed. Call an authorised technician if the anomaly persists (e.g. Immergas After-sales Service).

Parasite flame block. This occurs in case of a leak on the detection circuit or anomaly in the flame control unit. It is possible to reset the boiler to allow a new attempt at ignition. If the boiler does not start contact a qualified technician (e.g. Immergas After-Sales Technical Assistance Service).

Push button control panel anomaly. This occurs when the circuit board detects an anomaly on the push button control panel. If normal conditions are restored the boiler restarts without having to be reset. If this anomaly persists, contact a qualified technician for assistance (e.g. Immergas After-Sales Service).

Block due to flue gas temperature gradient intervention. If the board detects a rapid increase of flue gas temperature probably due to a blocked pump or lack of water in the heat exchanger, the boiler blocks due to the flue gas temperature gradient intervention. To eliminate it, the Reset button (3) must be pressed. If this phenomenon occurs frequently, contact a qualified technician for assistance (e.g. Immergas After-Sales Technical Assistance Service).

Insufficient circulation. This occurs if there is overheating in the boiler due to insufficient water circulating in the primary circuit; the causes can be:

- low system circulation; check that no shut-off devices are closed on the heating circuit and that the system is free of air (deaerated);
- circulating pump blocked; free the circulating pump.

If this phenomenon occurs frequently, contact a qualified technician for assistance (e.g. Immergas After-Sales Technical Assistance Service).

Flue probe anomaly. If the board detects an anomaly on the flue probe, the boiler will not start; contact a qualified technician for assistance (e.g. Immergas After-Sales Technical Assistance Service).

Loss of Remote Control communication. This occurs 1 minute after communication loss between the boiler and the remote control). To reset the error code, remove and re-apply voltage to the boiler. If this phenomenon occurs frequently, contact a qualified technician for assistance (e.g. Immergas After-Sales Technical Assistance Service).

IMG Bus communication loss. If due to an anomaly on the boiler control unit, the communication is lost between the control units on the zones control unit (optional) or on the IMG Bus, the boiler does not satisfy the room central heating requests. A qualified technician must be called (e.g. Immergas After-Sales Service).

Low power supply voltage. This occurs when the power supply voltage is lower than the allowed limits for the correct functioning of the boiler. If normal conditions are restored, the boiler re-starts without having to be reset. If this phenomenon occurs frequently, contact a qualified technician for assistance (e.g. Immergas After-Sales Technical Assistance Service).

Loss of flame signal. This occurs when the boiler is ignited correctly and the burner flame switches off unexpectedly; a new attempt at ignition is performed and if normal conditions are restored, the boiler does not have to be reset (this anomaly can only be checked in the list of errors P19 present in the "M1" menu). If this phenomenon occurs frequently, contact a qualified technician for assistance (e.g. Immergas After-Sales Technical Assistance Service).

Block due to loss of continuous flame signal. This occurs if the "Flame signal loss" error occurs 6 times consecutively in 8.5 minutes (38)". To eliminate the block, the Reset button (3) must be pressed. If this phenomenon occurs frequently, contact a qualified technician for assistance (e.g. Immergas After-Sales Technical Assistance Service).

Block for maximum time, gas valve opening. This occurs if the gas valve remains open for a time longer than that envisioned for normal functioning, without the boiler switching on. To eliminate the block, the Reset button (5) must be pressed. If this phenomenon occurs frequently, contact a qualified technician for assistance (e.g. Immergas After-Sales Technical Assistance Service).

Low temperature safety thermostat intervention (optional). During normal functioning, if an anomaly causes excessive overheating of the flow temperature in low temperature conditions, the boiler blocks. In this case, after suitable cooling, it is possible to reset the thermostat (see relative instructions sheet). If this phenomenon occurs frequently, contact a qualified technician for assistance (e.g. Immergas After-Sales Technical Assistance Service).

Burner power limitation. If the heat exchanger is blocked, the boiler reduces the power supplied so as not to damage it. A qualified technician must be called (e.g. Immergas After-Sales Technical Assistance Service).

Signalling and diagnostics - Display of the CAR^{v2}Remote Control (Optional). During normal boiler functioning the CAR^{v2} remote control display shows the room temperature value; in the case of malfunctioning or anomaly, the display of the temperature is replaced by the relative error code present in the previous table.

2.6 INFORMATION MENU.

By pressing the "Info" button (4), the "Information menu" is activated, which allows to display some boiler functioning parameters.

Press the "Info" button (4) to scroll the various parameters.

To exit the menu, press the "Info" button (4) up to the end of the list, or by pressing the "Reset" button (3) or by waiting for 15 minutes.

With the menu active, the indicator (14) will alternately show the indication of the parameter via the letter "d" plus the number of the parameter that is being displayed and the value of the parameter itself.

Parameter Id	Description
d1	Displays the flame signal (uA x 10 approximate)
d2	Displays the primary exchanger output instant heating flow temperature
d3	Displays the temperature of the storage tank unit (if the same is present)
d4	Displays the values set for central heating set
d5	Displays the values set for DHW set
d6	Displays the external temperature (if external probe present) If the temperature is below zero, the value is displayed flashing.
d7	Not available
d8	Not available
d9	Displays the list of the last five anomalies. (to scroll the list, turn the CH temperature selector (6))

2.7 BOILER SHUTDOWN

For complete boiler switch-off, press the “off” button, disconnect the onnipolar switch outside of the boiler and close the gas cock upstream from the appliance. Never leave the boiler switched on if left unused for prolonged periods.

2.8 RESTORE HEATING SYSTEM PRESSURE

Periodically check the system water pressure. The boiler manometer should read a pressure between 1 and 1.2 bar.
If the pressure falls below 1 bar (with the circuit cool) restore normal pressure via the valve located at the bottom of the boiler (Fig. 2-2).

N.B.:close the valve after the operation. If pressure values reach around 3 bar the safety valve may be activated.

In this case contact a professional technician for assistance.

In the event of frequent pressure drops, contact qualified staff for assistance to eliminate possible system leakage.

2.9 DRAINING THE SYSTEM.

To drain the boiler, use the special system draining valve (Fig. 2-2)
Before draining, ensure that the system filling valve is closed.

2.10 ANTI-FREEZE PROTECTION.

The boiler has an anti-freeze function that switches on automatically when the temperature falls below 4°C (standard protection to minimum temperature of -5°C). All information relative to the anti-freeze protection is stated in Par. 1.4. In order to guarantee the integrity of the appliance and the domestic hot water heating system in zones where the temperature falls below zero, we recommend the central heating system is protected using anti-freeze liquid and installation of the Immergas Anti-freeze Kit in the boiler. In the case of prolonged inactivity (second case), we also recommend that:

- the electric power supply is disconnected;
- the heating circuit and boiler domestic water circuit must be drained. In systems that are drained frequently, filling must be carried out with suitably treated water to eliminate hardness that can cause lime-scale.

2.11 CASE CLEANING.

Use damp cloths and neutral detergent to clean the boiler casing. Never use abrasive or powder detergents.

2.12 DECOMMISSIONING.

In the event of permanent shutdown of the boiler, contact professional staff for the procedures and ensure that the electrical, water and gas supply lines are shut off and disconnected.

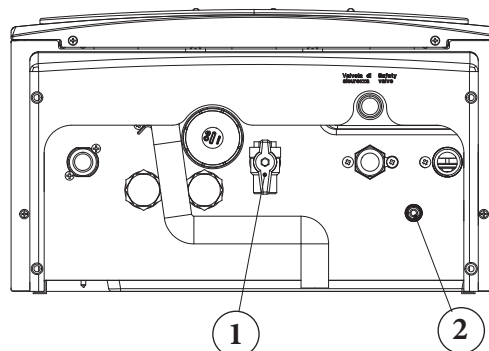
Bottom view.

Key:
1 - Filling valve
2 - Draining valve

2-2

3 BOILER COMMISSIONING (INITIAL CHECK)

To commission the boiler:

- ensure that the declaration of conformity of installation is supplied with the appliance;
- ensure that the type of gas used corresponds to boiler settings;
- check connection to a 230V-50Hz power mains, correct L-N polarity and the earthing connection;
- make sure the heating system is filled with water and that the manometer indicates a pressure of 1±1.2 bar.
- switch the boiler on and ensure correct ignition;

- check the Δp gas values in domestic hot water and heating modes;
- check the CO_2 in the combustion products at maximum and minimum flow rate;
- check activation of the safety device in the event of no gas, as well as the relative activation time;
- check activation of the main switch located upstream from the boiler and in the boiler;
- check that the intake and/or exhaust terminals are not blocked;
- ensure activation of all adjustment devices;
- seal the gas flow rate regulation devices (if settings are modified);
- check the production of DHW (when the boiler is connected to an external cylinder unit);

- ensure sealing efficiency of water circuits;
- check ventilation and/or aeration of the installation room where provided.

If any checks/inspection give negative results, do not start the boiler.

3.1 HYDRAULIC DIAGRAM.

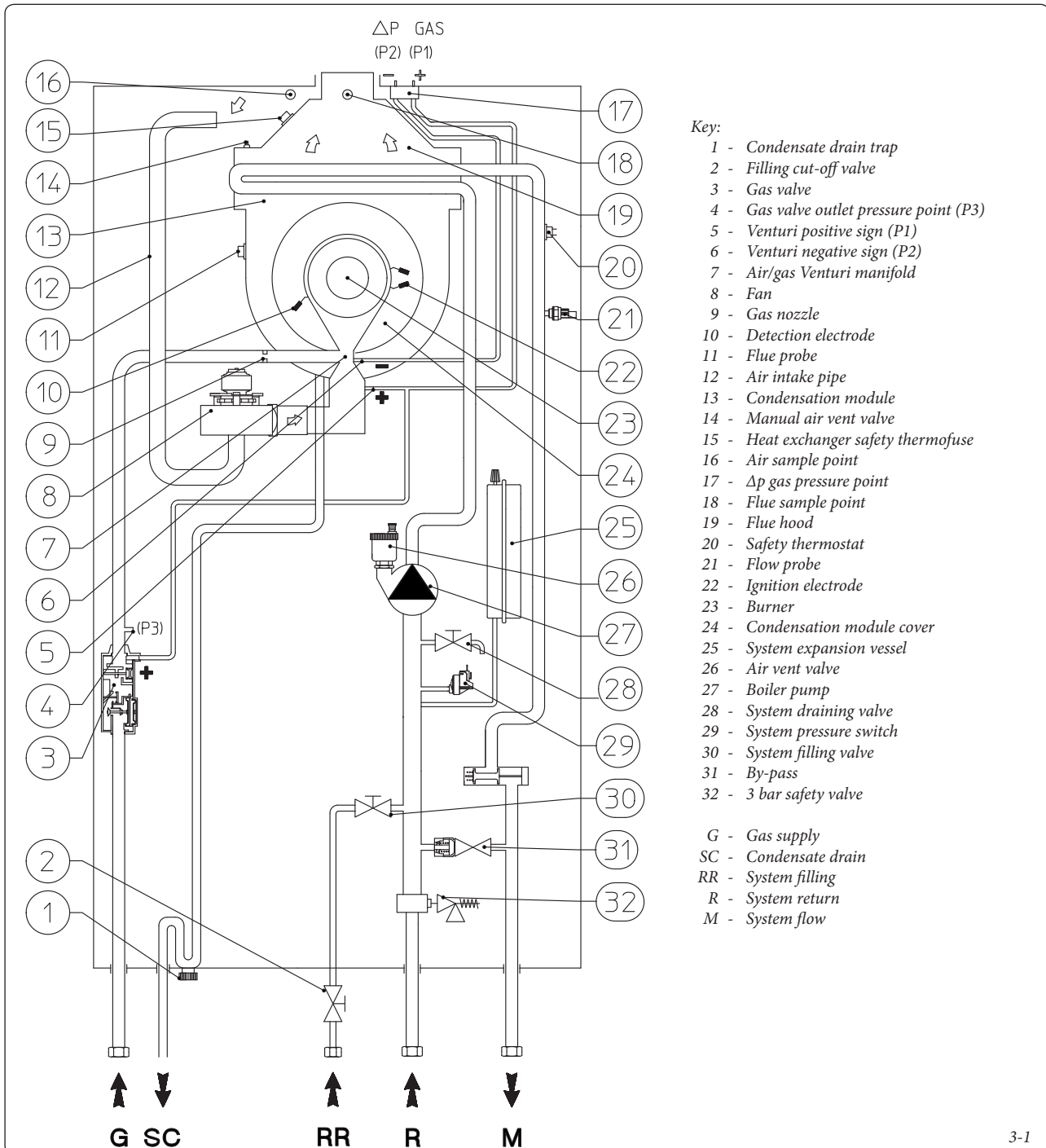

INSTALLER

USER

TECHNICIAN

3.2 WIRING DIAGRAM.

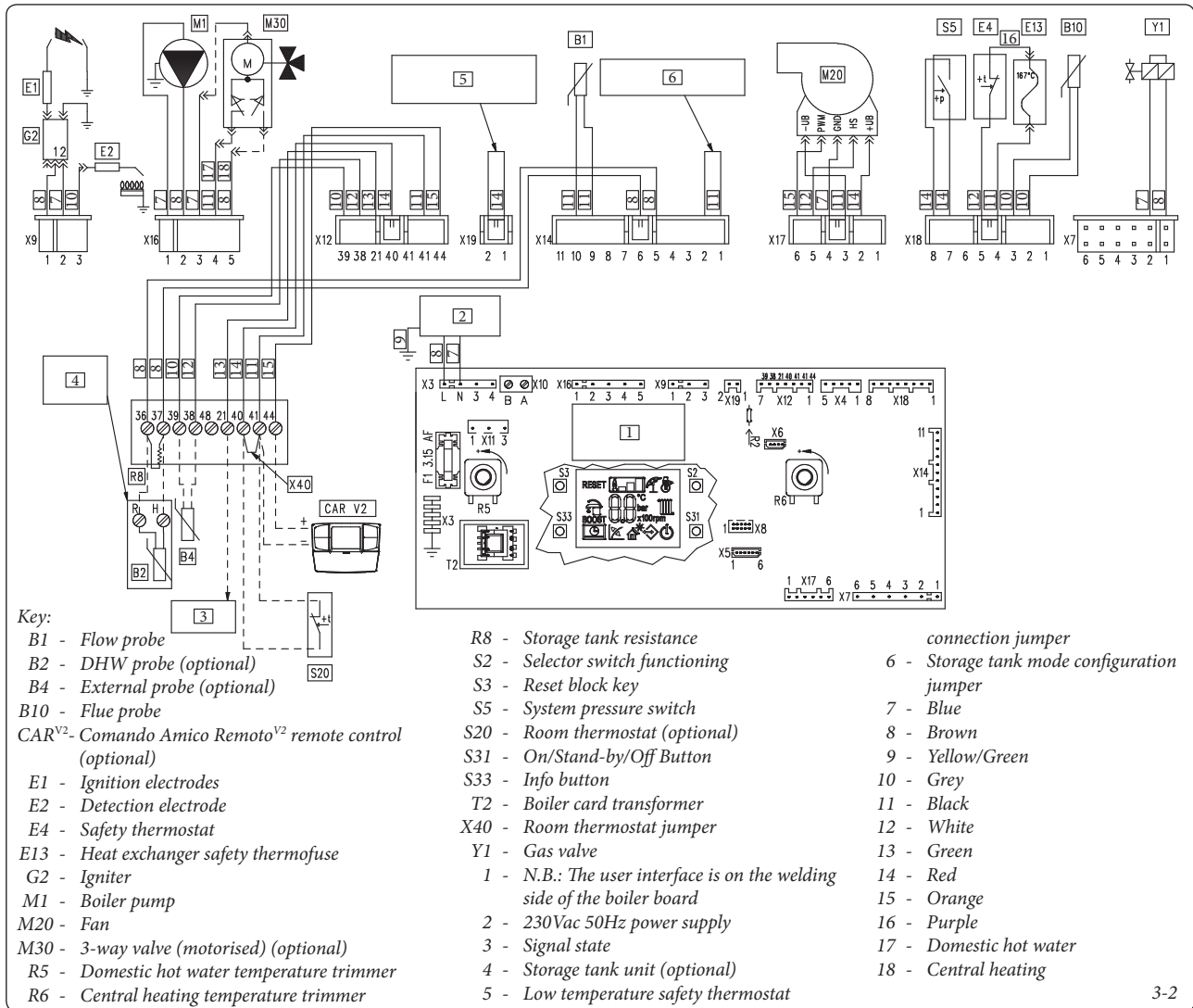

Comando Amico Remoto remote control: the boiler is prepared for the application of the Comando Amico Remoto remote control (CAR^{V2}, which must be connected to clamps 41 and 44 of the terminal board (positioned under the sealed chamber) respecting the polarity and eliminating jumper X40.

Room thermostat: the boiler is prepared for the application of the room thermostat (S20), which must be connected to clamps 40 and 41 of the terminal board (positioned under the sealed chamber) eliminating jumper X40.

Storage tank unit: the boiler is prepared for connection to a storage tank unit, which must be connected to clamps 36 and 37 of the terminal board (positioned under the sealed chamber) eliminating resistance R8.

The connector X5 is used for the connection to the relay P.C.B.

The connector X6 is for connection to a personal computer.

The connector X8 is used for software updating operations.

3.3 TROUBLESHOOTING

N.B.: maintenance interventions must be carried out by a qualified technician (e.g. Immergas After-Sales Technical Assistance Service).

- Smell of gas. Caused by leakage from gas circuit pipelines. Check sealing efficiency of gas intake circuit.
- Repeated ignition blocks. It can be caused by no gas, check the presence of pressure in the network and that the gas adduction valve is open. Incorrect adjustment of the gas valve, check the correct calibration of the gas valve.
- Irregular combustion or noisiness. This may be caused by: a dirty burner, incorrect combustion parameters, intake-exhaust terminal not correctly installed. Clean the above components and ensure correct installation of the terminal, check correct setting of the gas valve (Off-Set setting) and correct percentage of CO₂ in flue gases.
- Frequent activation of the temperature overload thermostat. It can depend on the lack of water in the boiler, little water circulation in the system or blocked pump. Check on the manometer that the system pressure is within established limits. Check that the radiator valves are not closed and also the functionality of the pump.

- Siphon blocked. This may be caused by dirt or combustion products deposited inside. Check, by means of the condensate drain cap, that there are no residues of material blocking the flow of condensate.
- Heat exchanger blocked. This may be caused by the trap being blocked. Check, by means of the condensate drain cap, that there are no residues of material blocking the flow of condensate.
- Noise due to air in the system. Check opening of the hood of the special air vent valve (Fig. 1-28). Make sure the system pressure and expansion vessel pre-charge values are within the set limits; The factory-set pressure values of the expansion vessel must be 1.0 bar, the value of system pressure must be between 1 and 1.2 bar.

3.4 CONVERTING THE BOILER TO OTHER TYPES OF GAS.

If the boiler has to be converted to a different gas type to that specified on the data plate, request the relative conversion kit for quick and easy conversion.

Boiler conversion must be carried out by a qualified technician (e.g. Immergas Technical Assistance Service).

To convert to another type of gas the following operations are required:

- remove the voltage from the appliance;
- replace the nozzle located between the gas pipe and gas/air mixing sleeve (Part. 7 Fig. 1-28), taking care to remove the voltage from the appliance during this operation;
- apply voltage to the appliance;
- calibrate the number of fan revs. (Par. 3.5);
- adjust the correct air/gas ratio (Par. 3.6);
- seal the gas flow rate devices (if adjusted);
- after completing conversion, apply the sticker, present in the conversion kit, near the data-plate. Using an indelible marker pen, cancel the data relative to the old type of gas.

These adjustments must be made with reference to the type of gas used, following that given in the table (Par. 3.19).

3.5 CALIBRATION OF NUMBER OF FAN REVS.

Important: verification and calibration is necessary, in the case of transformation to other types of gas, in the extraordinary maintenance phase with replacement of the circuit board, air/gas circuit components or in the case of installations with flue gas extraction systems, with horizontal concentric pipe measuring more than 1 metre.

The boiler heat output is correlated to the length of the air intake and flue exhaust pipes. This decreases with the increase of pipe length. The boiler leaves the factory adjusted for minimum pipe length (1m). It is therefore necessary, especially in the case of maximum pipe extension, to check the Δp gas values after at least 5 minutes of burner functioning at nominal heat output, when the temperatures of the intake air and exhaust flue gases have stabilised. Adjust the nominal and minimum heat output in the domestic hot water and central heating modes according to the values in the table (Par. 3.19) using the differential manometers connected to the Δp gas pressure point (15 and 16 Fig. 1-28).

Enter the configurations menu and regulate the following parameters (Par. 3.8):

- DHW minimum power output;
- DHW maximum power output;
- minimum heating output;
- maximum central heating output;
- ignition power.

3.6 ADJUSTMENT OF THE AIR-GAS RATIO.

Important: the verification operations of the CO₂ must be carried out with the casing mounted, while the gas valve calibration operations must be carried out with the casing open and removing the voltage from the boiler.

Calibration of the minimum CO₂ (minimum heating power).

Enter the chimney sweep phase without withdrawing domestic hot water and take the selector switches to minimum (turn them in an anti-clockwise direction until "0" is seen on the display), to have an exact value of CO₂ in the flue gases the technician must insert the sampling probe to the bottom of the sample point, then check that the CO₂ value is that specified in the table, otherwise adjust the screw (3 Fig. 3-4) (Off-Set adjuster). To increase the CO₂ value, turn the adjustment screw (3) in a clockwise direction and vice versa to decrease it.

Calibration of the maximum CO₂ (nominal central heating power).

On completion of the adjustment of the minimum CO₂ keeping the chimney sweep function active, take the heating selector switch to maximum (turn it in a clockwise direction until "99" is seen on the display). To have an exact value of CO₂ in the flue gases the technician must insert the sampling probe to the bottom of the sample point, then check that the CO₂ value is that specified in the table, otherwise adjust the screw (12 Fig. 3-4) (Gas flow adjuster).

To increase the CO₂ value, turn the adjustment screw (12) in an anti-clockwise direction and vice versa to decrease it.

At every adjustment variation on the screw 12 it is necessary to wait for the boiler to stabilise itself at the value set (about 30 sec.).

Victrix X 12 2I		
	CO ₂ at nominal output (central heating)	CO ₂ at minimum output (central heating)
G 20	9.50% ± 0.2	8.85% ± 0.2
G 30	12.50% ± 0.2	11.60% ± 0.2
G 31	10.60% ± 0.2	10.20% ± 0.2

Victrix X 24 2I		
	CO ₂ at nominal output (central heating)	CO ₂ at minimum output (central heating)
G 20	9.50% ± 0.2	8.9% ± 0.2
G 30	12.30% ± 0.2	11.60% ± 0.2
G 31	10.60% ± 0.2	10.20% ± 0.2

3.7 CHECKS FOLLOWING CONVERSION TO ANOTHER TYPE OF GAS.

After making sure that conversion was carried out with a nozzle of suitable diameter for the type of gas used and the settings are made at the correct pressure, check that the burner flame is not too high or low and is stable (does not detach from burner);

N.B.: All boiler adjustment operations must be carried out by a qualified technician (e.g. Immergas Assistance Service).

SIT 848 Gas Valve

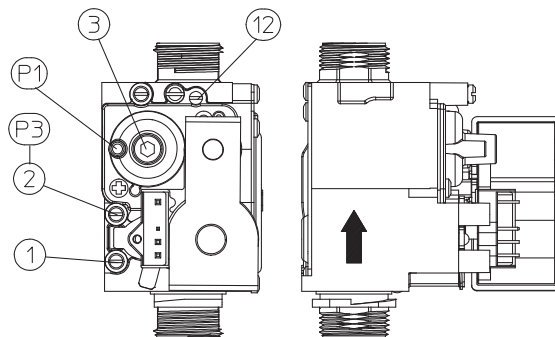

Key:

- 1 - Gas valve inlet pressure point
- 2 - Gas valve outlet pressure point
- 3 - Off/Set adjustment screw
- 12 - Outlet gas flow rate adjuster

3.8 PROGRAMMING THE P.C.B.

The boiler is prepared for possible programming of several operation parameters. By modifying these parameters as described below, the boiler can be adapted according to specific needs.

To access the programming phase, position the DHW selector (5) on position "6", the CH selector (6) on position "9" and press the "Reset" (3) and "Summer/Winter" buttons for about 8 seconds (2).

Once the menu has been accessed, it is possible to scroll through the three sub-menus present (s, p, t) by pressing the "Summer/Winter" (2) button for 1 second.

Use the "DHW regulator" selector (5), to select the parameter (inside the same sub-menu) and rotate the "CH regulator" selector (6) to modify the value according to the range available.

Press the "Reset" button (3) for 1 second to memorise the variation of the parameters. Memorisation is represented via "88" on the indicator (14) for 2 seconds.

Exit the programming mode by waiting for 15 minutes or by pressing the, "Reset" (3) and "Summer/Winter" (2) buttons simultaneously.

Parameter Id	Parameter	Description	Range	Default
S0	Minimum DHW output	The boiler also has electronic modulation that adapts the boiler potentiality to the effective heating demand of the house. Therefore the boiler works normally in a variable gas pressure field between minimum and maximum power depending on the system heat load, setting fan speed (in rpm, hundreds of revs are represented on the display).	900 ÷ 1500	G20 = 1050 LPG = 960
S1	Maximum DHW output		4000 ÷ 6100	G20 = 5000 LPG = 4450
S2	Minimum CH output	N.B.: the boiler is produced and calibrated in the central heating phase at nominal output. Approximately 10 minutes are needed to reach the nominal heat output, which can be changed using the parameter (S3).	S0 ÷ S3	G20 = 1050 LPG = 960
S3	Maximum CH output		S2 ÷ S1	G20 = 5000 LPG = 4450
S4	Power block	N.B.: selection of parameters in the presence of requests, allows boiler functioning with current equal to the respective value.	1500 ÷ 3500	2300
S5	Central heating set point minimum temperature	Defines the minimum flow temperature.	20 ÷ 50 °C	25
S6	Central heating set point maximum temperature	Defines the maximum flow temperature.	(S5+5) ÷ 85 °C	85
S7	External probe correction	If the reading of the external probe is not correct it is possible to correct it in order to compensate any environmental factors. (Over the value of +9 the display shows "CE", which enables an external control function of the boiler for coupling of the same with a system supervisor)	-9 ÷ 9 K	0
S8	Boiler power	Identifies the power of the boiler on which the P.C.B. is installed	0 = 12 kW 1 = 26 kW 2 = 28 kW 3 = 32 kW	0

Parameter Id	Parameter	Description	Range	Default
P0	DHW thermostat	Establishes the boiler ignition and switch-off mode in DHW mode. 0 - Ignition occurs when the water contained in the storage tank drops by 7°C with respect to the temperature set and switches off when the temperature is at -4°C with respect to the value set (solar deactivated) 1 - Ignition occurs when the water contained in the storage tank drops by 2°C with respect to the temperature set and switches off when the temperature is at +1°C with respect to the value set (solar deactivated) 2 - Ignition occurs when the water contained in the storage tank drops by 10°C with respect to the temperature set and switches off when the temperature is at the value set (solar deactivated)	0 On = -7°C Off = -4°C 1 On = -2°C Off = +1°C 2 On = -10°C Off = +0°C	2
P1	Solar delay timing	This function does not affect the correct functioning of this boiler model.	0 - 30 seconds	0
P2	Pump functioning	The pump can function in two ways. 0 intermittent: In winter "mode" the pump is managed by the room thermostat or by the remote control 1 continuous: In "winter" mode the pump is always powered and so functions continuously	0 - 1	0
P3	Relay 1 (optional)	The boiler is set-up for functioning with the relay board (optional), which can be configured 0 = Off 1 = Main zone control 2 = General alarm 3 = CH phase active 4 = External gas valve power supply 5 = (Do not use on this boiler model)	0 - 5	1
P4	Relay 2 (optional)	The boiler is set-up for functioning with the relay board (optional), which can be configured 0 = Off 1 = General alarm 2 = CH phase active 3 = External gas valve power supply 4 = Secondary zone control (from TA on relay board contact) 5 = Heat pump	0 - 5	0
P5	Relay 3 (optional)	The boiler is set-up for functioning with the relay board (optional), which can be configured 0 = Off 1 = Chiller remote activation 2 = General alarm 3 = CH phase active 4 = External gas valve power supply 5 = heat pump 6 = activation of storage tank pump	0 - 6	0

Parameter Id	Parameter	Description	Range	Default
t0	Central heating ignitions timer	The boiler has electronic timing, which prevents the burner from igniting too often in central heating mode (with step of 10)	0 - 600 seconds	18
t1	Central heating ramp timer	In the ignition phase, the boiler performs an ignition ramp in order to arrive at the maximum power set (with step of 10)	0 - 840 seconds	18
t2	CH ignition delay from TA and CR request	The boiler is set to switch-on immediately after a request. In the case of particular systems (e.g. area systems with motorised thermostatic valves etc.) it could be necessary to delay switch-on (with 10 step)	0 - 600 seconds	0
t3	Display lighting	Establishes the display lighting mode. 0 Automatic: the display lights up during use and lowers after 15 seconds of inactivity. In the case of anomaly the display flashes. 1 Low: the display is always lit with low intensity 2 High: the display is always lit with high intensity.	0 - 2	0
t4	Display	Establishes what the indicator displays 14 (Fig. 2-1). "Summer" mode: 0: the indicator is always off 1: pump active displays the flow temperature, pump off the indicator is off "Winter" mode: 0: always displays the value set on the CH selector 1: pump active displays the flow temperature, pump off always displays the value set on the CH selector	0 - 1	1

3.9 SOLAR PANELS COUPLING FUNCTION.

The boiler is set-up to receive water. In the event of integration of heating of the DHW with solar panel systems, the boiler is set by default for management of the storage tank unit via parameter "P0" set on "2" (Par. 3.8).

3.10 "CHIMNEY SWEEP FUNCTION".



When activated, this function forces the boiler to variable output for 15 minutes.

In this state all adjustments are excluded and only the safety thermostat and the limit thermostat remain active. To activate the chimney sweep function, press the "Reset" button (3) until activation of the function in the absence of DHW requests.

Its activation is signalled by simultaneous flashing of the indicators (11 and 12 Fig. 2-1).

This function allows the technician to check the combustion parameters.

Once the function is activated, it is possible to select whether to make the check in CH status or DHW status by opening any hot water cock and regulating the power by turning the "CH regulation" selector (6).

Functioning in CH or DHW mode is visualised by the relative symbols  or .

After the checks, deactivate the function switching the boiler off and then on again.

3.11 PUMP ANTI-BLOCK FUNCTION.

The boiler has a function that starts the pump at least once every 24 hours for the duration of 30 seconds in order to reduce the risk of the pump becoming blocked due to prolonged inactivity.

3.12 THREE-WAY ANTI-BLOCK SYSTEM

Both in "domestic hot water" and in "domestic hot water-central heating" phase the boiler is equipped with a function that starts the three-way motorised group 24 hours after it was last in operation, running it for a full cycle so as to reduce the risk of the three-way group becoming blocked due to prolonged inactivity.

3.13 RADIATORS ANTI-FREEZE FUNCTION.

If the system return water is below 4°C, the boiler starts up until reaching 42°C.

3.14 P.C.B. PERIODICAL SELF-CHECK.

During functioning in heating mode or with boiler in standby, the function activates every 18 hours after the last boiler check/power supply. In case of functioning in domestic hot water mode the self-check starts within 10 minutes after the end of the withdrawing in progress, for duration of approx. 10 seconds.

N.B.: during self-check, the boiler remains off.

3.15 AUTOMATIC VENT FUNCTION.

In the case of new heating systems and in particular mode for floor systems, it is very important that deaeration is performed correctly. The function consists in the cyclic activation of the pump (100 s ON, 20 s OFF) and the 3-way valve (120 s domestic hot water, 120 s central heating).

The function is activated in two different ways:

- at every new power supply of the boiler;
- by pressing buttons at the same time (2 and 4 Fig. 2-1) for 5 seconds with boiler in stand-by.

N.B.: if the boiler is connected to the CAR^{V2}, the "stand-by" function is only obtained via the remote control panel.

In the first case, the function has duration of 8 minutes and it can be interrupted by pressing the "reset" button (4). In the second case it has duration of 18 hours and it can be interrupted by simply switching the boiler on.

Activation of the function is signalled by the countdown shown on the indicator (14).

3.16 SYSTEM SUPERVISION COUPLING FUNCTION.

The boiler is set-up to be coupled to a system functioning with heat pump. For coupling, a "System supervisor" kit is necessary and the following operations must be performed:

- set "S7" on "CE";
- connect the system supervisor to clamps 38 (-) and 39 (+) of the boiler terminal board respecting the polarity.

For further information, see the system supervisor instruction book.

3.17 YEARLY APPLIANCE CHECK AND MAINTENANCE.

The following checks and maintenance should be performed at least once a year.

- Clean the flue side of the heat exchanger.
- Clean the main burner.
- Check correct lighting and operation.
- Ensure correct calibration of the burner in domestic water and heating phases.
- Check correct operation of control and adjustment devices and in particular:
 - intervention of main electrical switch on boiler;
 - system control thermostat intervention;
 - domestic hot water control thermostat intervention.
- Check sealing efficiency of gas circuit and the internal system.
- Check intervention of the device against no gas ionisation flame control:
 - check that the relative intervention time is less than 10 seconds.
- Visually check for water leaks or oxidation from/on connections and traces of condensate residues inside the sealed chamber.
- Check, by means of the condensate drain cap, that there are no residues of material blocking the flow of condensate.
- Check contents of the condensate drain trap.
- Visually check that the water safety drain valve is not blocked.
- Check that, after discharging system pressure and bringing it to zero (read on boiler manometer), the expansion vessel charge is at 1.0 bar.
- Check that the system static pressure (with system cold and after refilling the system by means of the filling valve) is between 1 and 1.2 bar.
- Check visually that the safety and control devices have not been tampered with and/or shorted, in particular:
 - temperature safety thermostat;
- Check the condition and integrity of the electrical system and in particular:
 - electrical power cables must be inside the whipping;
 - there must be no traces of blackening or burning.

N.B.: on occasion of periodical maintenance of the appliance it is appropriate also to check and perform maintenance on the heating system, in compliance with that indicated by the regulations in force.

3.18 CASING REMOVAL.

To facilitate boiler maintenance the casing can be completely removed as follows:

- disassemble the lower plastic protection grid (1) by loosening the two lower screws (2);
- loosen the two screws (4) present in the lower part of the casing front (3);
- loosen the two screws (4) present in the lower part of the casing front (3);
- unhook the central fixing (6) exerting slight pressure in the median zone of the side (5);
- pull the front casing slightly in the lower part towards yourself and push upwards at the same time (see figure);
- loosen the 2 front screws on the control panel (7);
- loosen the screws (8) present in the front part of the two sides (5);
- pull the sides lightly to the outside and loosen the two rear screws using a screwdriver with long point (9).

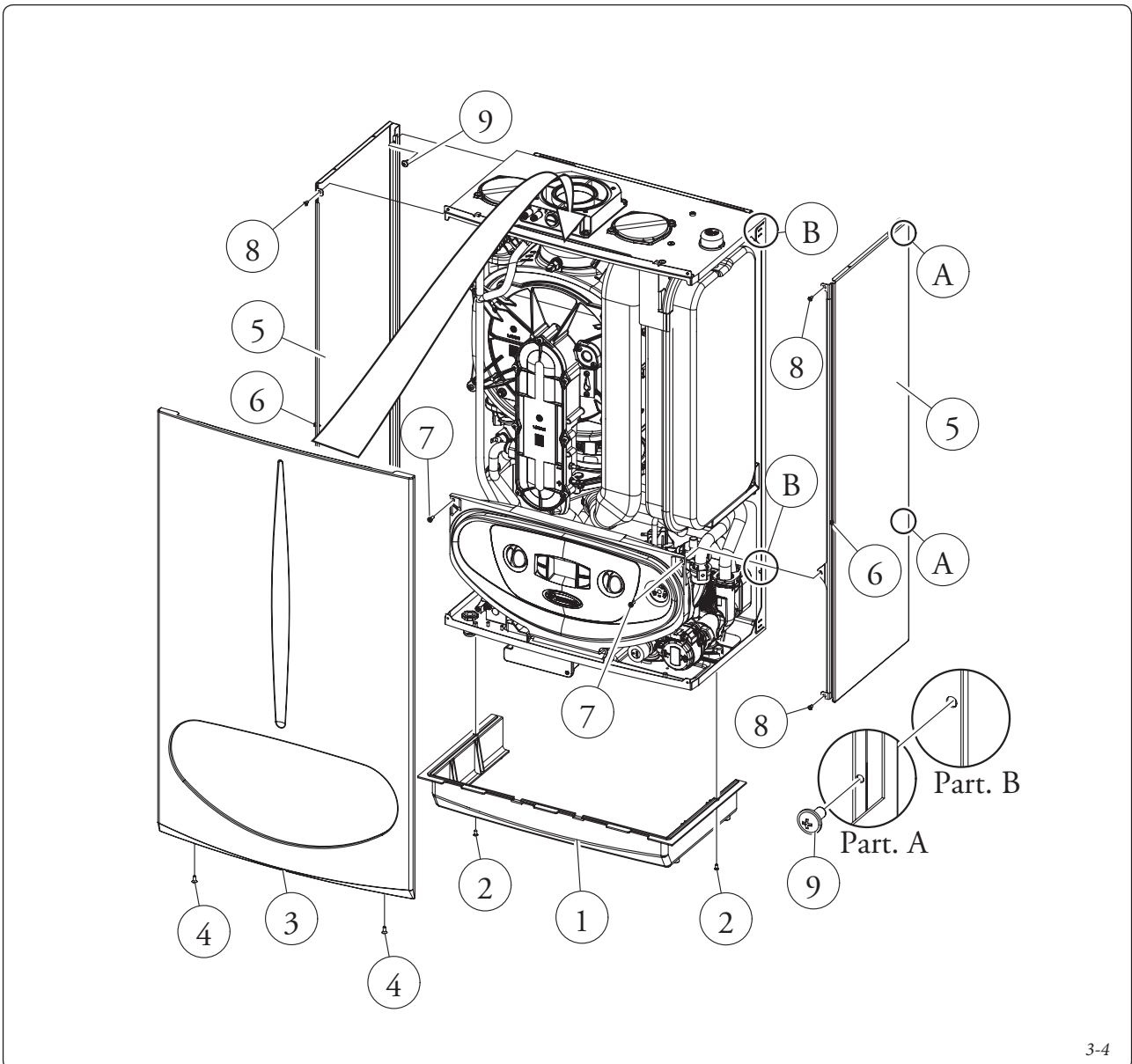

3-4

3.19 VARIABLE HEAT POWER.

N.B.: the pressures indicated in the table represent the differences of pressures at the ends of the Venturi mixer and can be measured from the pressure point in the upper part of the

sealed chamber (see pressure test 15 and 16 Fig. 1-28). The adjustments must be performed using a digital differential manometer with a scale in tenths of mm or Pascal. The power data in the table has been obtained with intake-exhaust pipe

measuring 0.5 m in length. Gas flow rates refer to heating values below a temperature of 15°C and at a pressure of 1013 mbar. Burner pressure values refer to use of gas at 15°C.

Victrix X 12 2 I.

		METHANE (G20)			BUTANE (G30)			PROPANE (G31)		
HEAT OUTPUT	HEAT OUTPUT	BURNER GAS FLOW RATE	BURNER NOZZLES PRESSURE		BURNER GAS FLOW RATE	BURNER NOZZLES PRESSURE		BURNER GAS FLOW RATE	BURNER NOZZLES PRESSURE	
(kW)	(kcal/h)	(m³/h)	(mbar)	(mm H ₂ O)	(kg/h)	(mbar)	(mm H ₂ O)	(kg/h)	(mbar)	(mm H ₂ O)
12.0	10320	1.30	5.60	57.1	0.97	5.33	54.4	0.95	6.59	67.2
11.0	9460	1.19	4.76	48.5	0.89	4.47	45.6	0.87	5.51	56.2
10.0	8600	1.08	3.99	40.7	0.81	3.70	37.7	0.79	4.55	46.4
9.8	8456	1.06	3.87	39.5	0.79	3.58	36.5	0.78	4.40	44.9
8.0	6880	0.87	2.68	27.3	0.65	2.40	24.5	0.64	2.94	29.9
7.0	6020	0.76	2.12	21.6	0.57	1.87	19.0	0.56	2.27	23.1
6.0	5160	0.66	1.62	16.5	0.49	1.40	14.3	0.48	1.69	17.3
5.0	4300	0.55	1.18	12.0	0.41	1.00	10.2	0.40	1.20	12.2
4.0	3440	0.44	0.80	8.1	0.33	0.66	6.8	0.33	0.79	8.1
3.0	2580	0.34	0.47	4.8	0.25	0.39	4.0	0.25	0.47	4.8
2.0	1720	0.23	0.20	2.1	0.17	0.20	2.0	0.17	0.24	2.4
1.9	1634	0.22	0.18	1.8	0.16	0.18	1.8	0.16	0.22	2.2

Victrix X 24 2 I.

		METHANE (G20)			BUTANE (G30)			PROPANE (G31)		
HEAT OUTPUT	HEAT OUTPUT	BURNER GAS FLOW RATE	BURNER NOZZLES PRESSURE		BURNER GAS FLOW RATE	BURNER NOZZLES PRESSURE		BURNER GAS FLOW RATE	BURNER NOZZLES PRESSURE	
(kW)	(kcal/h)	(m³/h)	(mbar)	(mm H ₂ O)	(kg/h)	(mbar)	(mm H ₂ O)	(kg/h)	(mbar)	(mm H ₂ O)
26.0	22360	2,82	5,60	57,1	2,11	5,50	56,1	2,07	7,10	72,4
25.0	21500	2,71	5,19	52,9	2,02	5,06	51,6	1,99	6,54	66,7
24.0	20640	2,60	4,79	48,9	1,94	4,65	47,4	1,91	6,00	61,2
23.6	20296	2,55	4,64	47,3	1,91	4,49	45,8	1,87	5,80	59,1
22.0	18920	2,38	4,05	41,4	1,77	3,88	39,6	1,74	5,02	51,2
21.4	18405	2,31	3,85	39,2	1,72	3,67	37,4	1,70	4,74	48,3
20.0	17200	2,16	3,39	34,6	1,61	3,19	32,6	1,58	4,13	42,1
19.0	16340	2,05	3,08	31,4	1,53	2,88	29,4	1,51	3,72	38,0
18.0	15480	1,94	2,79	28,4	1,45	2,58	26,3	1,43	3,34	34,1
17.0	14620	1,84	2,51	25,6	1,37	2,30	23,5	1,35	2,98	30,4
16.0	13760	1,73	2,25	22,9	1,29	2,04	20,8	1,27	2,64	26,9
15.0	12900	1,62	2,00	20,4	1,21	1,80	18,3	1,19	2,32	23,7
14.0	12040	1,52	1,76	18,0	1,13	1,57	16,0	1,11	2,03	20,7
13.0	11180	1,41	1,55	15,8	1,05	1,36	13,8	1,03	1,75	17,9
12.0	10320	1,30	1,34	13,7	0,97	1,16	11,9	0,96	1,50	15,3
11.0	9460	1,20	1,15	11,7	0,89	0,98	10,0	0,88	1,27	12,9
10.0	8600	1,09	0,97	9,9	0,81	0,82	8,4	0,80	1,06	10,8
9.0	7740	0,98	0,81	8,2	0,73	0,67	6,9	0,72	0,86	8,8
8.0	6880	0,88	0,66	6,7	0,65	0,54	5,6	0,64	0,69	7,1
7.0	6020	0,77	0,52	5,3	0,57	0,43	4,4	0,56	0,54	5,5
6.0	5160	0,66	0,40	4,0	0,49	0,33	3,4	0,49	0,41	4,2
5.0	4300	0,55	0,29	2,9	0,41	0,25	2,6	0,41	0,30	3,1
4.0	3440	0,44	0,19	1,9	0,33	0,19	1,9	0,33	0,22	2,2
3.0	2580	0,33	0,11	1,1	0,25	0,14	1,4	0,25	0,15	1,5

3.20 COMBUSTION PARAMETERS.

		G20	G30	G31
Supply pressure	mbar (mm H ₂ O)	20 (204)	29 (296)	37 (377)
Victrix X 12 2 I				
Gas nozzle diameter	mm	3.70	2.80	2.80
Flue flow rate at nominal heat output	kg/h	19	17	20
Flue flow rate at min heat output	kg/h	3	3	3
CO ₂ at Nom Q./Min.	%	9.50 / 8.85	12.50 / 11.60	10.60 / 10.20
CO with 0% O ₂ at Nom Q /Min.	ppm	110 / 4	440 / 4	115 / 1
NO _x with 0% O ₂ at Nom Q /Min.	mg/kWh	48 / 13	185 / 20	85 / 25
Flue temperature at nominal output	°C	56	63	57
Flue temperature at minimum output	°C	58	64	59
Victrix X 24 2 I				
Gas nozzle diameter	mm	5.60	4.00	4.00
Flue flow rate at nominal heat output	kg/h	42	38	43
Flue flow rate at min heat output	kg/h	5	5	5
CO ₂ at Nom Q./Min.	%	9.50 / 8.90	12.30 / 11.60	10.60 / 10.20
CO with 0% O ₂ at Nom Q /Min.	ppm	200 / 4	650 / 4	190 / 3
NO _x with 0% O ₂ at Nom Q /Min.	mg/kWh	47 / 15	170 / 30	45 / 18
Flue temperature at nominal output	°C	57	63	57
Flue temperature at minimum output	°C	58	64	59

INSTALLER

USER

TECHNICIAN

3.21 TECHNICAL DATA.

INSTALLER

USER

TECHNICIAN

		Victrix X 12 2 I	Victrix X 24 2 I
Domestic hot water nominal heat input	kW (kcal/h)	12,3 (10563)	26,7 (22933)
Central heating nominal heat input	kW (kcal/h)	12,3 (10563)	24,1 (20747)
Minimum heat input	kW (kcal/h)	2,0 (1753)	3,2 (2719)
Domestic hot water nominal heat output (useful)	kW (kcal/h)	12,0 (10320)	26,0 (22360)
Central heating nominal heat output (useful)		12,0 (10320)	23,6 (20296)
Minimum heat output (useful)		1,9 (1634)	3,0 (2580)
Efficiency 80/60 Nom./Min.	%	97,7 / 93,2	97,8 / 94,9
Efficiency 50/30 Nom./Min.	%	106,9 / 102,4	106,7 / 103,0
Efficiency 40/30 Nom./Min.	%	107,0 / 106,8	108,1 / 107,1
Heat loss at casing with burner On/Off (80-60°C)	%	0,89 / 0,30	0,41 / 0,50
Heat loss at flue with burner On/Off (80-60°C)	%	0,02 / 2,00	0,02 / 2,00
Central heating circuit max. operating pressure	bar	3	3
Central heating circuit max. operating temperature	°C	90	90
Adjustable central heating temperature	°C	20 ÷ 85	20 - 85
Total volume system heating expansion vessel	l	5,7	5,7
Heating expansion tank factory set pressure	bar	1,0	1,0
Water content in generator	l	3,0	3,4
Total head available with 1000 l/h flow rate	kPa (mm H ₂ O)	6,7 (0,68)	25,8 (2,64)
*Specific capacity "D" UB Immergas 80 l (ΔT 30°C) according to EN 625	l/min	17,2	20,5
*Specific capacity "D" UB Immergas 105 l (ΔT 30°C) according to EN 625	l/min	21,0	24,8
*Specific capacity "D" UB Immergas 120 l (ΔT 30°C) according to EN 625	l/min	21,1	27,1
*Specific capacity "D" UB Immergas 200 l (ΔT 30°C) according to EN 625	l/min	22,1	35,7
Drawing capacity in continuous duty with UB Immergas (ΔT 30°C)	l/min	6,3	13,54
Weight of full boiler	kg	39,5	42,4
Weight of empty boiler	kg	36,5	39,0
Electrical connection	V/Hz	230/50	230/50
Power input	A	0,53	0,58
Installed electric power	W	115	120
Pump consumption	W	83	88
Fan consumption	W	17	17
Equipment electrical system protection	-	IPX4D	IPX4D
Flue gas max. temperature	°C	75	75
NO _x class	-	5	5
Weighted NO _x	mg/kWh	19,0	36,0
Weighted CO	mg/kWh	6,0	15,0
Type of appliance	C13 / C13x / C23 / C33 / C33x / C43 / C43x / C53 / C83 / C93 / C93x / B33 / B53p		
Category	II2H3P		

- Flue temperature values refer to an air inlet temperature of 15°C and flow temperature of 50°C.
- The data relevant to domestic hot water performance refer to a dynamic inlet pressure of 2 bar and an inlet temperature of 15°C; the values are measured directly at the boiler outlet considering that to obtain the data declared mixing with cold water is necessary.

- The max. sound level emitted during boiler operation is < 55dBA. The sound level value is referred to semianechoic chamber tests with boiler operating at max. heat output, with extension of flue gas exhaust system according to product standards.
- * Specific capacity "D": domestic hot water flow rate corresponding to an average increase of 30K, which the boiler can supply in two successive withdrawals.

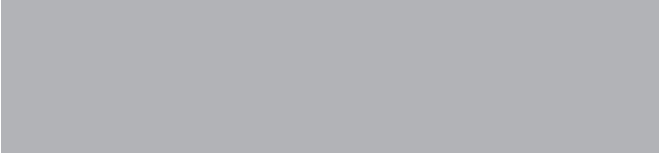

Immergas S.p.A.
42041 Brescello (RE) - Italy
T. +39.0522.689011
F. +39.0522.680617

immergas.com

