



Installation and Operating manual

Ethos 28cc

Ultra High Efficiency Gas Fired  
Condensing Combination Boiler

## Contents

1. Why choose Mikrofill? .....	6
2. Safety Considerations .....	7
3. Symbols .....	7
3.1 Gas Safety.....	7
4. Electrical Supply .....	7
5. Terms of Warranty .....	8
6. Commissioning Certificate .....	8
6.1 Requirements for the system quality .....	8
7. Existing Installations .....	8
7.1 Considerations prior to Connection .....	8
7.2 Expansion Vessels	9
8. Introduction.....	9
8.1 Variable Controlled Output. ....	9
8.2 Emissions .....	9
8.3 PPS Plastic Flue System .....	9
8.4 Approvals .....	9
8.5 Additional Features .....	9
9. Description of Appliances.....	10
9.1 EC 16, 23, 31 and 38 H.....	10
9.2 EC 16, 23, 31 and 38 HS.....	10
9.3 EC 16, 23, 31 and 38 S.....	10
10. Technical Information.....	11
11. Main Component Specification.....	13
11.1 Head Height of the Central Heating Circuit.13	
11.2 Air Fan Details .....	13
11.3 Gas Control Valve.....	13
12. Unpacking & Items Supplied .....	14
13. Accessories .....	14
14. Operation.....	15
14.1 Variable Controlled Output .....	15
14.2 Variable pump.....	15
14.3 Frost Protection.....	15
14.4 Year Long Protection.....	15
15. Siting the Appliance .....	15
15.1 Timber Framed Dwellings.....	16
16. Hydraulic Connections .....	16
16.1 First Fixing Pipe-work.....	16
16.2 Type 'H' Connections .....	16
16.3 Type 'HS' Connections.....	16
16.4 'S' Connections .....	17
16.5 Clearances .....	17
16.6 Checks before Siting .....	17
16.7 Fixing the boiler.....	17
16.8 Removing the Casing.....	17

17. Flues and Ventilation .....	18
17.1 Maximum Flue Lengths .....	18
17.2 Available Flue Components.....	20
17.3 Plumbing .....	21
17.4 Condensate in the Flue. ....	21
17.5 Flue Options. ....	21
17.6 Installing a Concentric Flue .....	21
17.7 Vertical flue Installations.....	23
17.8 Modular Installations .....	23
17.9 Fan Flued Terminal Positions .....	26
18. Gas Supply.....	26
18.1 Gas Supply.....	26
18.2 LPG Gas Supply .....	27
18.3 Setting The Gas Type .....	27
18.4 Conversion to LPG.....	27
19. Air Supply.....	28
19.1 Concentric Flue.....	28
19.2 Conventionally Flue.....	28
19.3 Compartment Ventilation.....	28
20. Hydraulic Requirements.....	29
20.1 Expansion Vessel.....	29
20.2 Hydraulic Resistance.....	30
20.3 Condensate Drain .....	30
20.4 System By-Pass.....	30
21. Electrical Connections.....	33
22. Heating Control Options.....	33
22.1 240 Volt Connections. ....	33
22.2 Low Voltage Connections. ....	34
22.3 Built-in clock.....	34
23. Boiler Control panel.....	34
24. Boiler Control Panel.....	35
24.1 System water pressure gauge .....	35
24.2 On / off switch. ....	35
24.3 Lcd control display .....	35
24.4 Menu - reset button.....	35
24.5 Summer winter button. ....	35
24.6 Engineers button.....	35
24.7 Test button.....	36
24.8 General.....	36
25. Menu options.....	36
25.1 Party.....	36
26. User programming.....	36
26.1 Hot Water Temperature.....	36
26.2 Day temperature function.....	36
26.3 Time/day function.....	36
26.4 Setting the ch timer.....	36
26.5 Setting the HW timer.....	38
26.6 Setting MR03 times.....	38
26.7 Night-time lower 0oc.....	38
26.8 Holiday function.....	38
26.9 Installer.....	38

27. Installer Programming.....	39
28. Outside Temperature Control.....	40
28.1 Flow Temperature at + 20°C.....	40
28.2 Outside Temp. Control at - 1°C.....	41
28.3 Minimum pump speed.....	41
28.4 Maximum pump speed.....	41
28.5 Flow temperature secondary circuit.....	41
28.6 Service counter.....	41
28.7 Pump continuous.....	41
28.8 Eco/eco+.....	41
28.9 Post running of pump after HW.....	41
28.10 Post running of pump after CH.....	41
28.11 Minimum DHW Capacity.....	42
28.12 Maximum DHW Capacity.....	42
28.13 Maximum CH capacity.....	42
28.14 Function Setting.....	43
29. Commissioning.....	47
29.1 Electrical Checks.....	47
29.2 Gas Supply.....	47
29.3 Connection to Pipe-work.....	47
29.4 Water Treatment.....	47
29.5 Flushing System Pipe-work.....	47
29.6 Filling and Venting the System.....	47
30. Combustion Ratio.....	48
30.1 Commissioning NG and LPG.....	48
31. Setting the Maximum CO <sub>2</sub> Value .48	
31.1 Flue System Check.....	49
31.2 STB Test Button (Green).....	49
32. Diagnostics.....	49
32.1 Control panel.....	49
33. Fault Finding.....	50
34. Handing the boiler over .....	54
34.1 Customer Familiarisation.....	54
35. Annual Servicing... ..	54
35.1 Service Inspection.....	54
35.2 Pre-preventative Maintenance.....	55
35.3 Service records.....	55
36. Decommissioning the boiler.....	55
37. User Instructions.....	56
37.1 Annual Servicing.....	56
37.2 Decommissioning the boiler.....	56
37.3 Built-in clock.....	56
37.4 Boiler Control Panel.....	57
37.5 System water pressure.....	57
37.6 On / off switch.....	57
37.7 Lcd control display.....	57
37.8 Menu - reset button.....	57
37.9 Summer winter button.....	57

37.10 Engineers button.....	57
37.11 Test button.....	57
37.12 General.....	57
<b>38. Programming Menu options .....</b>	<b>58</b>
38.1 Party.....	58
38.2 Hot Water Temperature.....	58
38.3 Day temperature function.....	58
38.4 Time/day function.....	58
38.5 Setting the ch timer.....	58
38.6 Setting the hw timer.....	59
38.7 Setting MR03 times.....	60
38.8 Night-time lower 0oc.....	60
38.9 Holiday function.....	60
38.10 Installer.....	60
<u>Figure 1 Overall Dimensions mm.....</u>	<u>12</u>
<u>Figure 2 Bottom View Dimensions mm.....</u>	<u>12</u>
<u>Figure 3 Top View Dimensions mm.....</u>	<u>13</u>
<u>Figure 4 Pump Head Height.....</u>	<u>13</u>
<u>Figure 5 Air Fan Curve.....</u>	<u>13</u>
<u>Figure 6 Gas Valve.....</u>	<u>13</u>
<u>Figure 7 Pipe-work Layouts.....</u>	<u>16</u>
<u>Figure 8 Minimum Clearances.....</u>	<u>17</u>
<u>Figure 9 Removing the Casing.....</u>	<u>17</u>
<u>Figure 10 Fixing Dimensions.....</u>	<u>18</u>
<u>Figure 11 Flue Design.....</u>	<u>19</u>
<u>Figure 12 Thermal Lift.....</u>	<u>20</u>
<u>Figure 13 Flue Preparation.....</u>	<u>21</u>
<u>Figure 14 Dimensions for cutting flue hole.....</u>	<u>22</u>
<u>Figure 15 Wall Terminal.....</u>	<u>22</u>
<u>Figure 16 Vertical Wall Terminal.....</u>	<u>23</u>
<u>Figure 17 Vertical Flue Application.....</u>	<u>23</u>
<u>Figure 18 Modular Installation.....</u>	<u>23</u>
<u>Figure 19 Vertical Roof Terminals.....</u>	<u>24</u>
<u>Figure 20 Concentric flue fittings.....</u>	<u>25</u>
<u>Figure 21 Concentric 80mm adaptor.....</u>	<u>25</u>
<u>Figure 22 80mm Flue Tubes.....</u>	<u>25</u>
<u>Figure 23 Fan Flued Terminal Positions.....</u>	<u>26</u>
<u>Figure 24 H Type Hydraulic system design.....</u>	<u>31</u>
<u>Figure 25 HS Type Hydraulic system design.....</u>	<u>31</u>
<u>Figure 26 S Type Combi Hydraulic system design.....</u>	<u>32</u>
<u>Figure 27 Electrical Connections.....</u>	<u>32</u>
<u>Figure 28 Connecting to the Mains.....</u>	<u>33</u>
<u>Figure 29 Boiler Control panel.....</u>	<u>34</u>
<u>Figure 30 Weather Compensation.....</u>	<u>40</u>
<u>Figure 31 O/T Ctrl Flow temp 85oC.....</u>	<u>40</u>
<u>Figure 32 O/T Ctrl Flow temp 70oC.....</u>	<u>40</u>
<u>Figure 33 O/T Ctrl Flow temp 50oC.....</u>	<u>40</u>
<u>Figure 34 Internal Wiring.....</u>	<u>46</u>
<u>Figure 35 Gas valve adjustments.....</u>	<u>49</u>
<u>Figure 36 Boiler Control panel.....</u>	<u>56</u>
<u>Table 1 Dimensions &amp; Connections.....</u>	<u>11</u>
<u>Table 2 Heating Specifications.....</u>	<u>11</u>
<u>Table 3 Capacities &amp; Weights.....</u>	<u>11</u>
<u>Table 4 Hot Water Specifications.....</u>	<u>12</u>
<u>Table 5 Connection Values.....</u>	<u>12</u>
<u>Table 6 Minimum Clearances.....</u>	<u>17</u>
<u>Table 7 Flue Resistance.....</u>	<u>19</u>
<u>Table 8 Flue Terminal Positions.....</u>	<u>26</u>

Table 9 Ventilation.....	28
Table 10 Expansion Vessel Req.....	29
Table 11 System Contents.....	30
Table 12 Programming Functions.....	39
Table 13 Installer Functions.....	39
Table 14 Minimum & Maximum fan speeds.....	48
Table 15 CO <sub>2</sub> Outputs.....	49
Table 16 LCD Display ' <b>NON FLASHING</b> '.....	50
Table 17 LCD ' <b>NON FLASHING</b> ' burner off.....	50
Table 18 Fault Display <b>FLASHING</b> .....	51
Table 19 Non Display Faults and Errors.....	51
Table 20 Reasons For Error Display.....	52

# HEALTH & SAFETY INFORMATION FOR THE INSTALLER AND SERVICE ENGINEER

Under the current issue of the Consumer Protection Act and the Health and Safety at Work Act it is a requirement to provide information on substances hazardous to health (COSSH Regulations).

Mikrofill takes every reasonable care to ensure that these products are designed and constructed to meet these general safety requirements, when properly used and installed. To fulfil this requirement each boiler is comprehensively tested before despatch.

When working on the appliance it is the Users/Installers responsibility to ensure that any necessary personal protective clothing or equipment is worn appropriate to parts that could be considered as being hazardous to health and Safety.

This appliance may contain some of the items below.

## **INSULATION AND SEALS**

Glass Rope, Mineral Wool, Insulation Pads, Ceramic Fibre, Glass Insulation. Which may be harmful if inhaled and may be irritating to the skin, eyes, nose or throat? When handling avoid inhalation and contact with eyes.

Use (disposable) gloves, face masks and eye protection where necessary.

After handling, wash hands and other exposed parts.

When disposing, reduce dust with water spray, ensure parts are securely wrapped.

## **GLUES, SEALANTS & PAINT**

Glues, Sealant and Paints used in the product present no known hazards when used in the manner for which they are intended.

## **2. Safety Considerations**

The installation of this appliance must be carried out by a competent person in accordance with the relevant Gas Safety Regulations (as amended), Building Regulations, Model Water Bylaws and the Building Standards (Scotland) Regulations. Mikrofill shall not be responsible for any damage or loss resulting from failure to carefully observe the instructions given.

**The boiler, except for commissioning purposes, should not be left operating without the casing being attached and firmly secured**

## **3. Gas Safety**

All gas appliances must, by law, be installed by competent persons, e.g. members of CORGI, in accordance with the Gas Safety Regulations. Failure to install appliances correctly could lead to prosecution

It is in your own interest and that of safety to ensure that the law is complied with.

Installer training courses are available for CORGI registered installers. Please contact Mikrofill for more information.

This installation manual contains all the necessary information required to install and commission the Ethos 28 range of boilers.

Please read this manual thoroughly before commencing installation. The installation must be carried out in accordance with the manual otherwise the warranty will be void. Use only original parts for service and maintenance.

After installation ensure the manual is kept close to the boiler and available for reference purposes.

The installation should also be in accordance with current editions and comply with the recommendations of the following British Standard Codes of Practice.

**CP.331.3 Low pressure installation pipes.**

**BS.6798 Boilers of rated output not exceeding 60kW.**

**BS.5546 Installation of gas hot water supplies for domestic purposes.**

**BS. 5449.1 Forced circulation hot water systems.**

**BS.5440.1 Flues (for gas appliances of rated input not exceeding 60kW).**

**BS.5440.2 Air supply (for gas appliances of rated input not exceeding 60kW).**



#### **4. Electrical Supply**

The wiring must comply with the current I.E.E. Wiring Regulations.

The Health and Safety Document No. 635 and the Electricity at Work Regulations 1989 must be followed where applicable.

The boilers are supplied for 230V +10/-15% 50Hz operation. The method of connection to the mains electrical supply **MUST** facilitate complete electrical isolation of the boiler. This may be achieved using a readily accessible 3 amp fused double pole switch clearly labeled.

#### **THESE APPLIANCES MUST BE EARTHED.**

**IMPORTANT** This boiler is an EC Certified Appliance and must not be modified or installed in any way contrary to these 'Installation and Servicing Instructions'.

The manufacturers instructions must **NOT** be taken in any way as over-riding statutory obligations.

#### **5 Requirements for the system quality**

Before commissioning the appliance it is essential to clean the installation in accordance with BS 7593: 1992. Installation of in-line strainers is obligatory. As a protection from corrosion and impurities the water additive Fernox MB1 has to be used and maintained (4%).

#### **6. Existing Installations**

##### **6.1 Considerations prior to Connection.**

##### *IMPORTANT*

**All Ethos boilers are low water content units. In order to protect and prolong the working life of the appliance, it is important the general condition of older systems is carefully considered.**

**When connecting to an existing installation it is important that system deposits are removed and are not allowed to contaminate boiler.**

This involves the application of a cleanser and allowing it to circulate around the whole system for a specified time, then flushing to drain. It is important to select the cleanser appropriate to the installation i.e. for a new installation, or for an existing installation.

It is good practice to clean the system prior to the installation of the new boiler. The removal of debris, flux residue, grease, metal swarf etc. from new systems and any black magnetic iron oxide sludge and lime scale from old systems is essential.

In-line strainers must be fitted to the return water connections for full protection. All installations must be treated with Fernox MB1 at a concentration of 4%.

**If plastic pipes are used to connect the boiler to radiators or under floor heating, it is essential that only those types of plastic pipe that incorporate an oxygen diffusion barrier be used. If such pipes are not used, the Mikrofill guarantee will become null and void.**

## **6.2 Expansion Vessels**

The Ethos 28 models are designed for connection to a fully pumped sealed heating system only. The appliance is fitted with a 10 litre expansion vessel.

An additional suitable sized expansion vessel may be required to accommodate water volume change on larger capacity systems.

Select an expansion vessel that matches the volume of the CH system and the static pressure.

Please contact Mikrofill Technical Department for assistance is required.

Installation should comply with BS7074 part 1 and BS5449.

## **7. Introduction**

The boiler features the very latest in technology. Developed around an innovative back panel the boiler uses laser welded waterways to interconnect the boiler's main components.

To facilitate ease of servicing stainless steel coiled heat exchanger and other major components are simply plugged into the panel.

The boiler incorporates a premixing, fully modulating, radiant gas burner, 3 bar pressure relief valve, manometer and circulating pump.

### **7.1 Variable Controlled Output**

The Ethos 28 cc incorporates a fully modulating output to ensure that the burner output is matched to the system requirements at all times.

### **7.2 Emissions.**

The premium burner has excellent combustion efficiencies and ultra low emissions levels, in excess of Zedbuk A classification.

### **7.3 Approvals**

The unit has been approved according to the European standards (CE) and the requirements for cleaner combustion (RAL UZ61)

### **7.4 Additional Features**

Corrosion resistant stainless steel heat exchanger. Integral sensors (PTC) for monitoring flow and return water temperatures. 3 way valve and facilities for connection to DHW storage. Computer controlled combustion analysis with built in fault diagnosis facility.

## **8. Description of Appliances**

### **8.1 Ethos 28cc**

This model is suitable for a central heating system with hot water output controlled using a 3 way diverter valve (spring return to heating). The appliance produces a low temperature output for under-floor heating or a fixed/variable temperature output for connection to radiators. Flow temperature to hot water cylinder can be set as required (max. 85°C)

Hot water cylinders must be indirect and to aid efficiency and fast recovery times (all appliances are hot water priority) should be of the high recovery type. Recommended minimum primary heat requirement - 25kW.

The unit has a variable capacity of 20 to 100%, while the maximum capacity can be set and adapted to the capacity of the CH system.

## 8.2 Ethos 28cc

This unit has a built-in heat secondary heat exchanger and Hot water production is continuous. The unit has a variable capacity of 20 to 100%, while the maximum capacity can be set and adapted to the capacity of the CH system.

### 10. Technical Information

**Table 1 Dimensions and Connections**

Product Identification Number	CE ~ 0085AR0057
Appliance Category	2ELL3B/P
Dimensions (H x W x D)	950mm x 458mm x 355mm
Heating Circuit Connections	22mm
Gas Connection	15mm
Condense Drain Connection	¾ BSP
Air Supply/Flue Connections	125/80mm

**Table 2 Heating Specifications**

Model – Ethos 28cc		E28
Maximum Rated Input	kW	22
Nominal Output To Heating 80/60°C	kW	21.4
Minimum Output To Heating 80/60°C	kW	3.1
Nominal Output To Heating 50/30°C	kW	23.1
Minimum Output To Heating 50/30°C	kW	3.6
CO <sub>2</sub> % content at max/min load	CO <sub>2</sub> % 9	9
Dew Point of Flue Gases	0°C	52
Flue Gas Temp @ 80/60°C (Amb 20°C)	0°C	75
* Maximum Flue Resistance	Pa	100
pH value of condensate water	PH	4-5.5
Pump Pressure @ 30kW and 20K Bar		0.15
Maximum Flow Temperature	0°C	85
Min/Max filling pressure	bar	0.5 - 3.0
**Efficiency @ 75/60°C	%	104
**Efficiency @ 40/30°C	%	108.5

\* At this resistance, the load will remain within the limits indicated on the data plate.

\*\* European calculation methods are based on efficiency of 100% in units that do not condense the flue gases, and of 110% in condensing units.

**Table 3 Capacities and Weights**

Model		EC23
Heating Water Capacity	litres	1.8
Heating Water Coil Capacity (S models)	Litres	1.3
Weight (empty)	Kg	37

**Table 4 Hot Water Specifications**

Model		EC23
Maximum Rated Input	kW	28.0
Modulating Output	kW	3.4-28
Hot Water Flow rates at $\Delta t$ 30K (S type)	L/min	13.4
Maximum Tap Water Pressure	bar	10

**Table 5 Power Details**

Min/Max Gas Pressure	mbar	15/50
Minimum Input Rate Natural Gas	m/h <sub>3</sub>	0.36
Maximum Input Rate Natural Gas	m/h <sub>3</sub>	2.67
Electrical Supply	VAC	230
Power Consumption Average	W	60

**Figure 1 Overall Dimensions mm.**

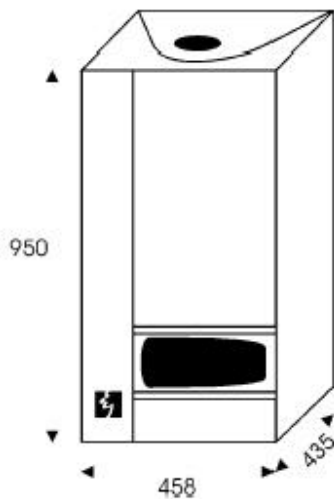

**Figure 2 Bottom View Dimensions mm.**

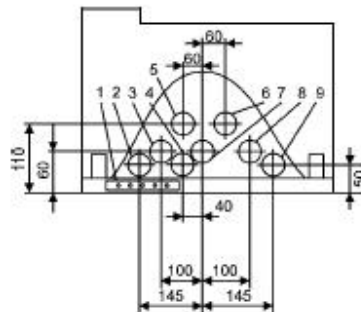

**Figure 3 Top View Dimensions mm**

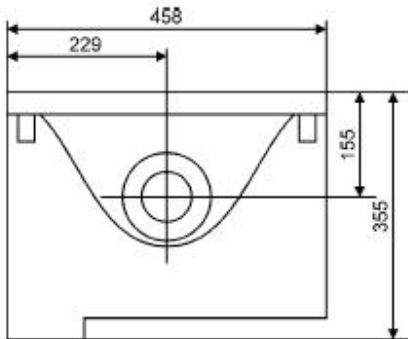

**11. Main Component Specification**

**11.1 Head Height of the Central Heating Circuit.**

**Figure 4 Pump Head Height**

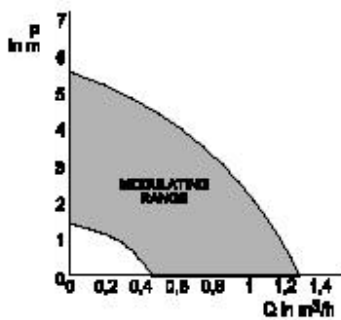

Volume of Water in Cu. Mts/ph. (m3/h.)

Grundfoss 240 Volt ~ 50Hz  
Wattage 59 ~ 115 W

**11.2 Air Fan Details.**

Type. EBM GIG128~13~13

**Figure 5 Air Fan Curve**

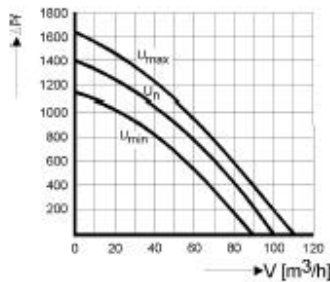

**11.3 Gas Control Valve.**

**Figure 6 Gas Valve**

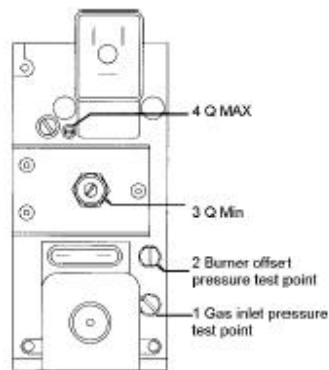

Adjustments

Turning 3 clockwise increases min output & CO2%

Turning 4 Anti clockwise increases max output CO2%

**12. Unpacking & Items Supplied**

The following items are supplied with the Boiler.  
Installation manual (to be left with the boiler). Replacement fuses (located top left of control panel). Vent key. Mounting bracket. Outside air temperature sensor

**13. Accessories**

The following items are also available from Mikrofill at extra cost.  
Colour coded 1/4 Turn Isolating Valves.  
Stainless Steel Flexible Pipe Connections.  
In line Filter/Strainers.

Condensate sump pump for below ground installations. N.B. LPG installations must not be installed below ground level.

Mikrofill servicing software and RS 2323 interface cable for connection to a PC.

Mikrofill modulating room sensor.

Mikrofill Cable for connecting three way diverter valve (external to boiler).

Mikrofill cascade manager for controlling multiple boiler installations supplying heat to the same system. A maximum of five boilers can be connected.

Mikrofill mixing valve control unit

For more details please contact the

Mikrofill technical department.

Mikrofill comprehensive range of flue kits, fittings and accessories.

80/125 Concentric 500 mm Fanned Flue Kit

80/125 1000mm length Galvanised Concentric Flue

80/125 500mm length Galvanised Concentric Flue

80/125 Galvanised 90 degree elbow

80/125 Galvanised 45 degree elbow

80mm 1000mm flue pipe

80mm 45 degree Elbow

80mm 45 degree connector

80/125 Roof Terminal

Pitched roof tile flashing

Aluminium flat roof terminal/chimney top flashing

80mm Wall Fixing Clamp

125mm Wall Fixing Clamp

80mm flexible flue liner (per metre)

80mm flexible flue liner 360 degree spacers

80mm flexible flue liner chimney terminal

80mm flexible flue liner chimney terminal clamp

80mm flexible flue liner boiler flue connector

#### **14. Operation**

A key component of the boiler is the fully modulating premix, radiant, gas burner, which is capable of producing a Variable Output (20% to 100% ratio).

As a result of the extremely low combustion temperatures produced during combustion, emissions of harmful atmospheric pollutants are dramatically reduced, (NO<sub>x</sub> 20mg\kWh CO 14mg\kWh).

### **14.1 Variable Controlled Output**

The microprocessor controlled modulation system with integral fault diagnostic facility, ensures that optimum efficiency is maintained when operating in both heating and DHW modes.

The premixing radiant burner modulates according to the required heat output.

A 24-Volt, high efficiency fan is used with a variable speed and power capacity; if the heat demand decreases, the fan will turn at a lower speed, which results in a lower power consumption.

The fan is programmed to supply given amounts of air for specific burner outputs.

The air pressure generated by the fan then controls the gas valve which in turn, matches the gas pressure to the required gas to air ratio.

The combustion gases then pass through the stainless steel heat exchanger to atmosphere.

### **14.2 Variable pump**

A variable speed integral circulating pump is supplied, which operates at different speeds and results in a lower power consumption (between 30 and 119 Watts). This feature is to help maintain a temperature difference of 20°C between the flow and return temperatures on systems using radiators.

### **14.3 Frost Protection**

If the flow temperature falls below 8°C, in order to provide frost protection, the pump will run even though there may be no demand for heat. If the temperature continues to fall, at 5°C, the burner will also ignite. At 10°C the appliance will return to standby mode. Remember when handing over the appliance to advise the end user on the precautions necessary to prevent frost damage to the system during frosty conditions. Stress the importance of leaving the system turned on e.g. continuous low temperature setting in extremely cold weather.

### **14.4 Year Long Protection**

During summer months, the pump and mixer valve (if fitted) are exercised daily. This prevents seizure of internal components thus reducing maintenance costs.

## **15. Siting the Appliance**

In siting the boiler, the following limitations **MUST** be observed

The boiler is not suitable for external use.

The installation **MUST** allow space for servicing to the front and below the boiler and for the circulation of ventilation air around the boiler. Figure 8 shows the minimum clearances required for safety and subsequent service. Due regard must be given to the flue discharge position to minimize possible plumbing.



The room must be dry and protected from frost.

With condensing boilers plumbing at the flue is a normal occurrence.

Any combustible material near to the boiler or its flue system and water pipe-work must be protected to ensure it does not exceed 65°C.

In certain locations the flue outlet may be susceptible to high winds or air turbulence which may create a negative flue pressure. Flue terminal outlets in such exposed conditions should be avoided. When operating at low fan speeds flame lift may occur. This can be overcome by raising the minimum fan speed.

The Ethos 28cc may be installed on the inner face of an external wall and some internal walls providing they are flat, vertical, of a non-combustible material and are capable of supporting the weight of the boiler and any other ancillary equipment. Where installation will be in an unusual location, special procedures may be necessary. Detailed guidance on this subject can be found in BS. 6798.

### 15.1 Timber Framed Dwellings

When installing the boiler into a timber framed dwelling, it must be fitted in accordance with the British Gas publication 'Guide for Gas Installations in Timber Framed Housing' ref. DM2.

For further advice contact the Mikrofill Technical Helpline.

## 16. Hydraulic Connections

### 16.1 First Fixing Pipe-work

All the pipe-work and wiring connections enter at the bottom of the unit. To ensure a tidy installation it is important to consider at the first fixing stage the order you arrange the pipe-work and if applicable any electrical trunking. Figure 7 shows the order in which to fix the pipe-work.

Figure 7 Pipe-work Layouts



### 16.2 Type 'H' Connections

- 1) Cable Gland
- 2) Syphon Flush (No permanent connection required)
- 3) Heating Flow ~ 22mm
- 4) Additional Cable Entry Point
- 5) Gas Inlet ~ 15mm.
- 6) Heating Return ~ 22mm.
- 7) Condensate Discharge ~ ¾ M.I.

### **16.3 Type 'HS' Connections.**

- 1) Cable Gland
- 2) Syphon Flush (No permanent connection required)
- 3) Heating Flow ~ 22mm
- 4) Additional Cable Entry Point
- 5) Flow Domestic Hot Water 22mm
- 6) Gas Inlet ~ 15mm
- 7) Return Domestic Hot Water 22mm
- 8) Heating Return ~ 22mm
- 9) Condensate Discharge ~ ¾ M.I.

### **16.4 'S' Connections.**

### **16.5 Clearances**

- 1) Cable Gland
- 2) Syphon Flush (No permanent connection required)
- 3) Heating Flow ~ 22mm.
- 4) Additional Cable Entry Point
- 5) Flow Domestic Hot Water 22mm
- 6) Gas Inlet ~ 15mm
- 7) Cold Mains Water ~ 22mm
- 8) Heating Return ~ 22mm
- 9) Condensate Discharge ~ ¾ M.I.

For ease of installation, necessary inspection and commissioning, the following clearances are recommended.

**Table 6 Minimum Clearances**

Sides	50mm
Above	250mm
Below	150mm
Front	455mm

**Figure 8 Minimum Clearances**

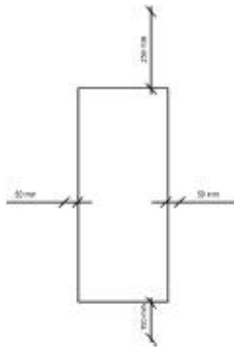

### 16.6 Checks Before Siting

Before commencing to install this appliance ensure the design specification complies with all of the requirements contained in these installation and servicing instructions and any statutory documents which may apply.

### 16.7 Fixing the boiler.

When unpacking the unit for the first time, take adequate precautions to protect the surrounding floor coverings. The boilers are factory tested and contain residues of water that could cause dampness and possible staining if contact with carpets and floor coverings is not prevented. Unpack the appliance and ensure that the items listed on have been supplied.

### 16.8 Removing the Casing

To remove the casing lay the unit down on the floor with the casing facing upper most. Loosen the centre screw and undo the two toggle casing clips located on the bottom of the unit. Pull the casing upwards, lifting up and off the internal locating lugs. Place the casing to one side taking care not to scratch the casing or control panel cover. (see figure 9.)

**Figure 9 Removing the Casing**

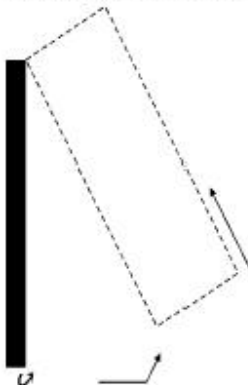

Take any necessary precautions to protect the surrounding working area and decorations from dust and damage. Make one final check on the location pay particular attention to the flue outlet (consider plumbing) and the condensate discharge pipe route.

Install the Ethos 29cc as close as possible to the hot water taps to avoid the hot water pipes from becoming too long. This prevents unnecessary waste of water.

When you are satisfied the location meets all the required criteria mark out the wall for required fixing points. Use the fixing bracket as a template.

**Figure 10 Fixing Dimensions**

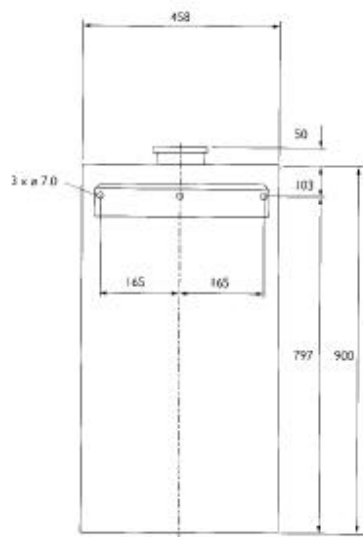

Check for horizontal and vertical alignment and drill 4 holes as marked using a No.14 masonry drill. Clear the surrounding area of any dust and debris and secure the mounting frame to the wall using suitable screws and plugs. Locate the boiler on the mounting frame.

**NB** The appliance should be 10mm off the wall measured at the base of the panel. Failure to observe this will result in condensate becoming trapped inside the heat exchanger. Component failures as a result of incorrect installation will not be covered by the boiler's normal warranty.

Please remember when using power tools to take all necessary safety precautions and always wear safety goggles.

## **17. Flues and Ventilation**

The internal boiler flue system is manufactured in P.P.S plastic and the flue outlet may be connected to an external P.P.S plastic or stainless steel flue system.

### **17.1 Maximum Flue Lengths**

The flue materials, flue insulation, the amount of vertical and horizontal pipe and the amount of bends incorporated determine the maximum permissible flue length. The excess fan pressure available for overcoming the frictional resistance of the flue system is 100 p.a.

**Figure 11 Flue Design**

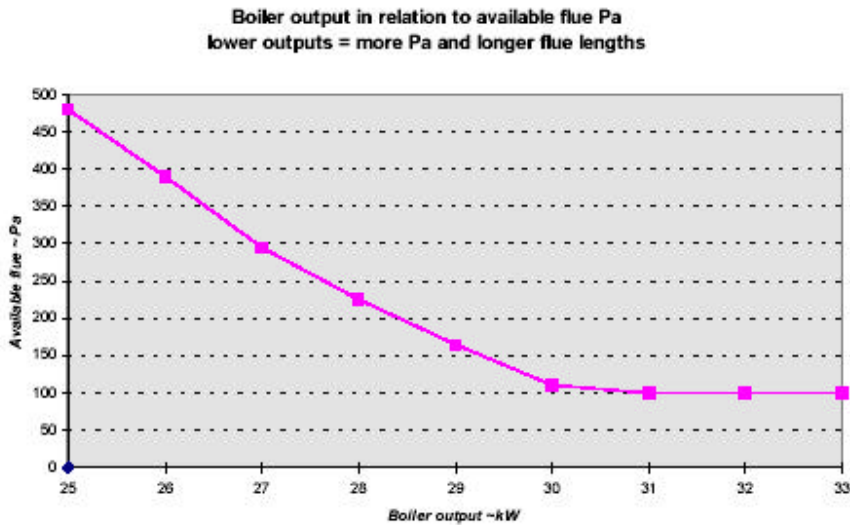

For the purposes of flue design when using the eco hometec PPS 125mm/80mm concentric flue system then refer to the table below for component resistances.

**Table 7 Flue Resistance**

COMPONENT RESISTANCE	P.a
80/125 Concentric 500 mm Fanned Flue Kit	5.0
80/125 1000mm length PPS/White Galvanised Concentric Flue	4.5
80/125 500mm length PPS/White Galvanised Concentric Flue	2.25
80/125 PPS/White Galvanised 90° elbow	4.0
80/125 PPS/White Galvanised 45° elbow	2.0
80mm 1000mm PPS flue pipe	2.5
80mm PPS 90° elbow	1.0
80mm PPS 45° elbow	.5
80/125 Roof Terminal	7.5
Open terminal with stainless steel mesh	2.5

For vertical external and internal flues there is a further gain from thermal lift. This can be calculated from the graph below.

Thermal lift is generated naturally in the vertical part of a flue system, reducing the overall resistance of the system.

The available lift may be calculated from the Thermal lift graph and deducted from the total calculated flue resistance.

For installations requiring greater flue lengths - please contact the Mikrofill technical department for advice.

The flue should terminate with a suitable terminal.

### 17.3 Plumbing

The siting of the terminal is not critical with regard to the performance of the appliance. However In certain locations the flue outlet may be susceptible to high winds or air turbulence. Sudden gusts may create a negative flue pressure. Flue terminal outlets in

such exposed conditions should be avoided. When operating at low fan speeds flame lift may occur. This can be overcome by raising the minimum fan speed. In certain conditions plumbing from the flue, although harmless, may cause a nuisance.

Please site the flue outlet to minimise any inconvenience the discharge of combustion products or possible plumbing may cause. Where a terminal is so sited to be less than 2m above the level of any ground, balcony, flat roof, or place to which people have access, or there is a likelihood of accidental contact by persons or damage to the terminal, a suitable guard **MUST** be fitted. Terminal guards are available from Mikrofill.

#### 17.4 Condensate in the Flue

Condensate formed must be cleared from the flue system and adequate care is required to ensure all flue pipes are self draining. All internal and external potential collecting points must be drained. In addition to avoid freezing external flue ductwork must be insulated.

To ensure the safe and satisfactory operation of the boiler the chimney system must be capable of the complete evacuation of combustion products at all times.

#### 17.5 Flue Options

The boiler may be installed either as a room sealed, fanned flued appliance using the Mikrofill P.P.S plastic 125mm/80mm concentric flue system or alternatively, conventionally flued, using a single skin 80mm P.P.S. plastic pipe.

#### 17.6 Installing a Concentric Flue

Connect the concentric elbow into the flue/vent connection. Mark the wall around the flue, remove the concentric elbow cover the appliance and cut or drill a 130mm diameter hole through the wall. Measure and cut the concentric flue pipe to pass through the previously made hole and into the concentric 90° bend. Figure 13 Flue Preparation

**Figure 13 Flue Preparation**

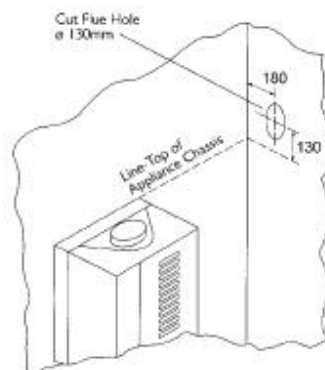

Apply a chamfered edge to the cut ends, apply silicone lubricant and insert through the wall and into the flue/air socket. The overall projection of the finished pipe should leave the air holes 20mm clear of the surrounding wall as per figure 15.

NOTE: When fitted, it is important to position the flue outlet with a slight fall so that the 80mm flue pipe is sloped back towards the boiler.

**Figure 14 Dimensions for cutting flue hole**

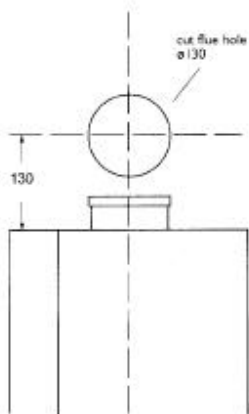

**Figure 15 Wall Terminal**

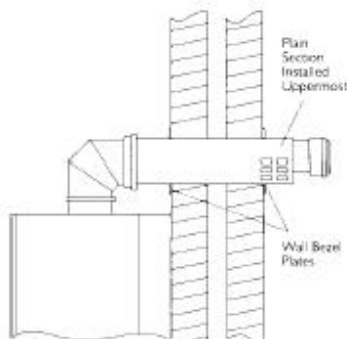

Failure to observe this requirement will result in condensate running out of the flue pipe and over the external brickwork causing possible staining and or freezing. Installed correctly the flue pipe will self drain back through the boilers internal condensate route. Make good to internal and external walls and fix an external stainless steel terminal guard if required.

The final location of the Flue Outlet terminal should comply with figure 23 and table 8. In certain circumstances the location of the boiler may leave the flue outlet in a position that does not comply with figure 23, or where plumbing is a nuisance.

The Mikrofill flue system has been designed to overcome this and the 80mm P.P.S. flue pipe may be simply re-routed to terminate in a more suitable location. To do this simply remove the 80mm stainless steel flue grill and insert either a 90° or 45° bend

Note: two 45° may be used to form a swan neck returning the flue pipe back to the wall for clipping.

Route the pipe to the desired location and terminate with a suitable bend to direct the flue gases away from the wall or any obstruction. When you are satisfied that the location complies with the requirements of figure 23 replace the stainless steel 80mm flue grill..

Alternatively a 90° terminal fitting may be purchased from Mikrofill and the flue routed vertically.

**Figure 16 Vertical Wall Terminal**

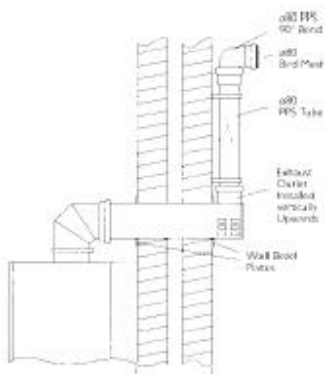

## 17.7 Vertical flue Installations

For vertical flue applications a range of fittings for both pitched and flat roofs are available. Please contact Mikrofill for further advice.

**Figure 17 Vertical Flue Application**

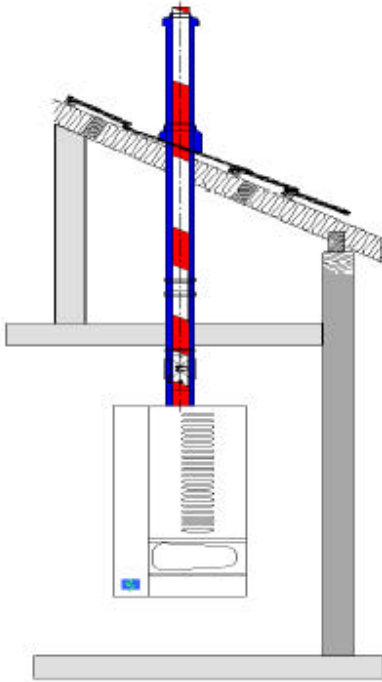

## 17.8 Modular Installations

For multiple boiler (modular) installations Mikrofill supply a range of larger diameter flues. Sizes are available in 150mm, 200mm and 250mm. For assistance in flue design and specification please call the Mikrofill technical department.

**Figure 18 Modular Installation**

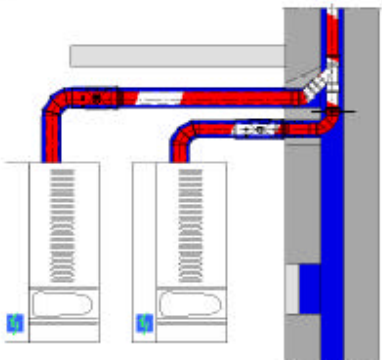

Concentric vertical flue fittings are available from Mikrofill. Concentric flue components have push together spigot and socket joints. The inner flue gas tube has silicone seal rings located in the socket component. The outer air tube has



EPDM rubber seal rings located in the socket component. To aid assembly and assurance that the joints have been fully pushed home, the seal rings and make ends of tubes and fittings should be lightly lubricated with silicone grease. Additional 80/125mm concentric flues tubes and fittings are available

**Figure 19 Vertical Roof Terminals**

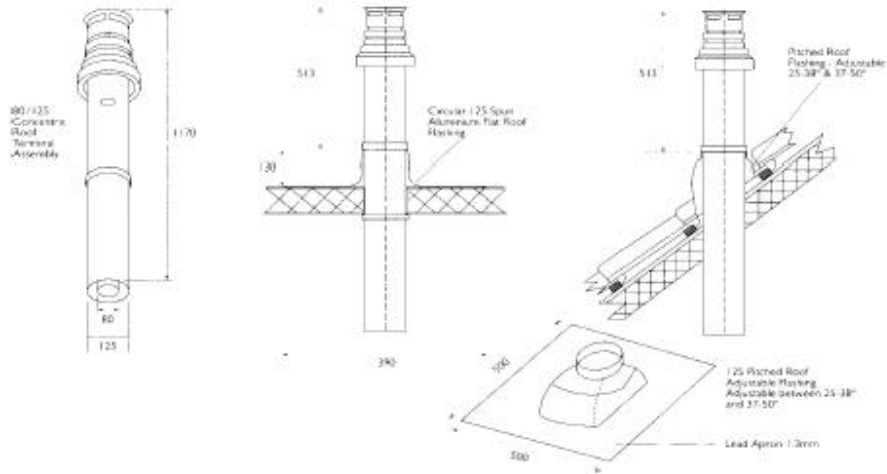

## 17.9 Fan Flued Terminal Positions

**Figure 23 Fan Flued Terminal Positions**

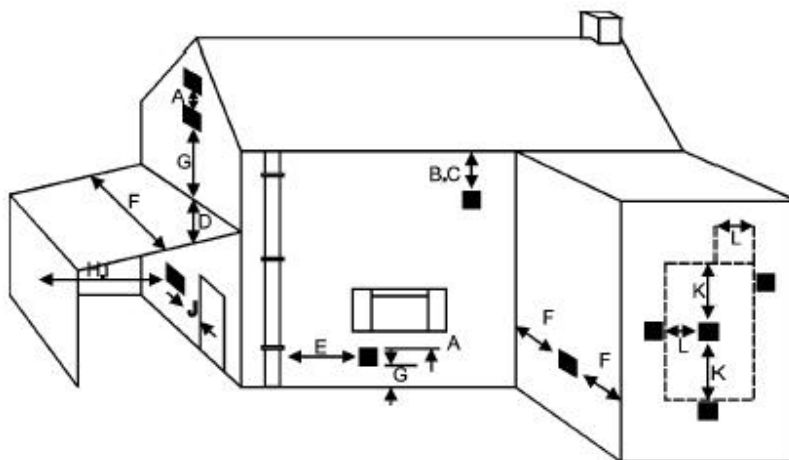

Terminal Positions	Min distance
A: Directly below an opening window or other opening, e.g. air brick	300mm
Directly above an opening window or other opening, e.g. air brick	300mm
B: Below gutters, soil pipes or drain pipes.	75mm
C: Below eaves	200mm
D: Below balconies or car port roof	200mm
E: From vertical drain pipes and soil pipes	150mm
F: From internal and external corners	300mm
G: Above ground roof or balcony	300mm
H: From a surface facing a terminal	600mm
J: From an opening in a car port (e.g. door, window) into a dwelling	1200mm
K: Vertically from a terminal on the same wall	1500mm
L: Horizontally from a terminal on the same wall	300mm

## 18. Gas Supply

The boiler is set for use with natural gas.

### 18.1 Gas Supply

Pipe-work from the meter to the boiler **MUST** be of an adequate size.

**DO NOT** use pipes of smaller size than the boiler inlet gas connection.

The gas supply to the boiler must be capable of maintaining a minimum pressure of 20 mbar measured at the inlet to the boiler, with all other gas appliances working.

The installer should install a pressure test point adjacent to the gas inlet connection.

### 18.2 LPG Gas Supply

For LPG the gas supply to the boiler must be capable of maintaining a minimum pressure of 37 mbar measured at the inlet to the boiler, with all other gas appliances working. The complete installation **MUST** be tested for soundness and purged in accordance with C.P. 331.3. The gas valve fitted to the boiler is not designed to withstand pressures in excess of 60 mbar.

When carrying out the pressure test on the service pipe-work it is essential that the gas cock fitted to the boiler is in the closed position, failure to do so will result in serious damage to the boiler.

### 18.3 Setting the Gas Type

When the Ethos 28cc leaves the factory it set up for use with Natural Gas. It can however be easily adjusted for use with LPG

#### **18.4 Conversion to LPG**

If the appliance is being used with LPG then a conversion kit is available from Mikrofill.

The contents of the LPG conversion kit include the following items:

1 x Propane injector 5.7mm

1 x Injector 3.5mm

1 x 10mm plastic air box plug

(for EC 16 & 23)

1 x 15mm plastic air box plug

1 x 13mm plastic air box plug

To convert the appliance to LPG complete the following procedure.

Isolate the boiler from the gas and electricity supplies.

Disconnect the unions either side of the gas valve.

Screw the 3.5 injector into the gas inlet side of the valve and the 5.7mm injector into the gas outlet side of the valve.

Close the hole in the front of the air box (attached to the air fan assembly) using a plastic plug included in the conversion kit.

Re-connect the gas valve making sure the sealing washers are located properly.  
Turn on gas supply and check for gas soundness.

Write on the identification plate that the appliance has been converted for LPG.

All gas service pipe-work from the meter to the boiler should be either mild steel pipe or copper.

## 19. Air Supply

### 19.1 Concentric Flue

If installed with a concentric flue and as a room sealed appliance the boiler does not require that room or internal space to have a permanent air supply.

### 19.2 Conventionally Flued

Safe, efficient and trouble-free operation of conventionally flued gas boilers is dependant on the provision of an adequate supply of fresh air to the room in which the appliance is installed. Ventilation by grilles communicating directly with the outside air or a ventilated adjacent room is required. Where the combustion air is being taken from an adjoining room the room itself must be ventilated to satisfy the combustion air requirement of the appliance. Where the appliance is to be installed as a conventionally flued appliance sufficient combustion air should also be allowed. To calculate the amount of free combustion air required for the appliance table 9 should be used. Permanent openings are based on the total maximum rated input.

Position ventilation grilles to avoid the risk of accidental obstruction by blocking or flooding. BS 5540.2

**Table 9 Ventilation**

Vent Position	Into room or internal space	Direct to outside air
High level	9 cm <sup>2</sup> per kW of input	4.5 cm <sup>2</sup> per kW of input
Low level	9 cm <sup>2</sup> per kW of input	4.5 cm <sup>2</sup> per kW of input
In a room or internal space	None required	None required
Conventionally flued appliance		
Vent Position	Into room or internal space	Direct to outside air
High level	9 cm <sup>2</sup> per kW of input	4.5 cm <sup>2</sup> per kW of input
Low level	18 cm <sup>2</sup> per kW of input	9.0 cm <sup>2</sup> per kW of input

Any air vent, which is to supply air to an open flued appliance, must not communicate with any room/space containing a bath or shower or private garage.

If further guidance on ventilation is required then consult BS. 5440.2.

Detailed recommendations for air supply requirements are given in BS.5440.2. and can also be found in the CORGI Gas

Installer Manual. The following notes are intended for general guidance only. Where open flued appliances total input ratings exceed 7 kW the room or internal space containing them must have an air vent of minimum effective area 4.5 cm<sup>2</sup> for every 1 kW in excess of 7 kW.

### 19.3 Compartment Ventilation

Due to the low standing losses compartment ventilation is not required.

## 20. Hydraulic Requirements

The boilers are intended to be used in conjunction with FULLY PUMPED, SEALED systems subject to the requirements below. They are NOT SUITABLE for use on gravity circulation systems. The boiler must not be used for direct hot water supply.

**Under floor heating:**

Despite the low boiler flow temperatures feature, in the event of control and/or mechanical failure or incorrect adjustment, to prevent damage to the installation or associated pipe work all low temperature under floor installations require an obligatory mixing valve installing as part of the system controls or a high limit thermostat set at 60°C.

In hard water areas suitable protection should be provided to prevent the build up of deposits in the primary hot water heat exchanger. The appliance guarantee does not extend to failure because of lime scale or other contamination.

Recommended minimum coil capacity 25kW.

The boiler must be capable of being adequately vented of air. Drain taps MUST be located in accessible positions, which permit the draining of the whole system including the boiler. Drain taps should be at least 1/2 inch BSP nominal size and be in accordance with BS. 2879.

In order to facilitate servicing of the unit, full flow isolating valves must be fitted to all water and gas connections.

**20.1 Expansion Vessel**

For systems having a larger water capacity, multiply the total water content (boiler and system) by the factor to obtain vessel size in litres.

**EXAMPLE 1.**

Central heating system filled to 1 bar. Total system water content 60 litres Multiply 60 (water content litres) x 0.11 (factor from chart) = 6.6 litres. Vessel required 6.6 litres. Vessel supplied 10 litres. Vessel adequate.

**EXAMPLE 2.**

Central heating system filled to 1 bar. Total system water content 150 litres Multiply 150 (water content litres) x 0.11 (factor from chart) = 16.5 litres. Vessel required 16.5 litres. Vessel supplied 10 litres. Vessel inadequate. Additional vessel 6.5 litres required.

When system content unknown or difficult to determine the following table can assist with calculating water content.

**Table 11 System Contents**

	Approx. Litres per kW
New Radiators	9
Old Radiators	12
U/Floor Heating	22

Expansion vessels should be connected to the system at a point close to the pump inlet in order to maintain positive pressure throughout the system.

The central heating system should be in accordance with the recommendations given in BS. 6798 and BS. 5449.

### **20.2 Hydraulic Resistance**

The integral boiler pump is designed to provide an adequate flow rate through the boiler at all times. Therefore, if an additional duty pump is to be fitted to the system, the boiler resistance can be ignored.

### **20.3 Condensate Drain**

The condensate discharge pipe should be continued in  $\frac{3}{4}$  inch **plastic waste pipe** into the household drainage system or out through the wall to an existing gully or soak away. To minimise the risk of freezing all condensate waste pipework fitted externally should be 32mm. (The existing drainage system should be corrosion resistant).

In order to avoid damage to the boiler caused by a blocked drainage system, the condensate disposal pipe should **include a tundish**. In these cases the pipe-work connected to the internal household drainage system should be fitted with a deep seal running trap.

Horizontal runs of condensate discharge pipe must fall at a rate of 40mm per metre and any external sections of pipe must be protected against the risk of freezing. Due care should be taken when installing the condensate disposal system to minimise the risk of blockage, as this would cause the condensate to back up inside the boiler.

Mikrofill will not accept any liability for damage caused to the boiler should this situation occur. If the connection to an existing drain is not possible, the condensate may be discharged into a purpose-built soak away.

When the boiler is installed below ground level, i.e. a basement or cellar, **(NB the appliance must not be installed below ground when using LPG)** provision should be made for the disposal of the condensate via a sump pump arrangement.

### **20.4 System By-Pass**

The boiler incorporates a bypass making it unnecessary to fit a system bypass.

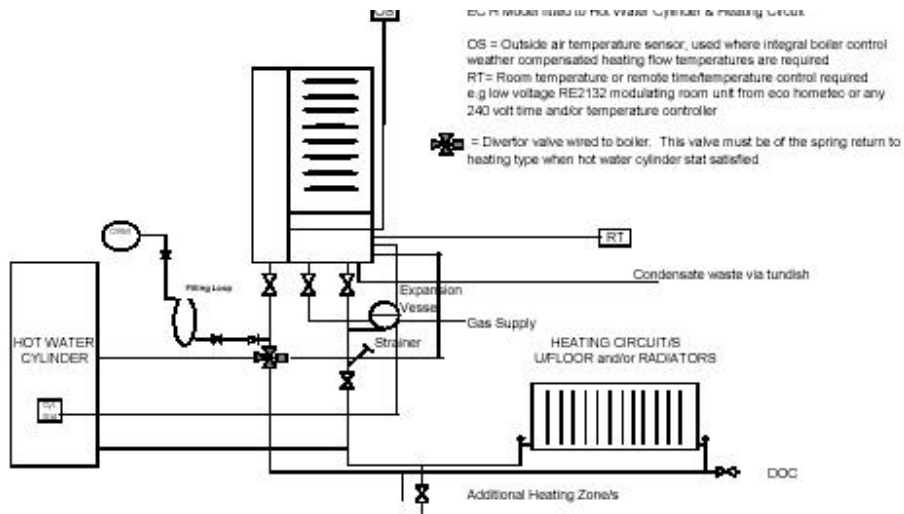

Typical installation serving domestic hot water and heating using integral expansion vessel and modulating circulating pump. Hot water production has priority controlled by spring return to heating diverter valve wired to boiler. Flow temperature to hot water is constant temperature to heating may be fixed or variable (weather compensated).

**Figure 26 S Type Combi Hydraulic system design**

(IMPORTANT SEE NOTE REF: 38/46kW model) Typical EC S (Combi) installation serving domestic hot water and heating using integral expansion vessel and modulating circulating pump. How water production has priority. Maximum flow temperature of hot water is constant temperature to heating may be fixed or variable (weather compensated).

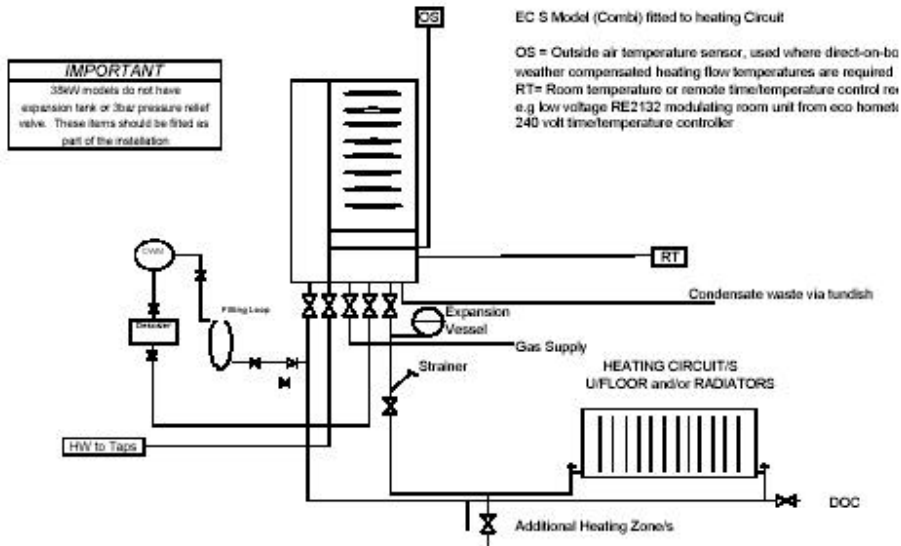

**Figure 27 Electrical**

**Connections**

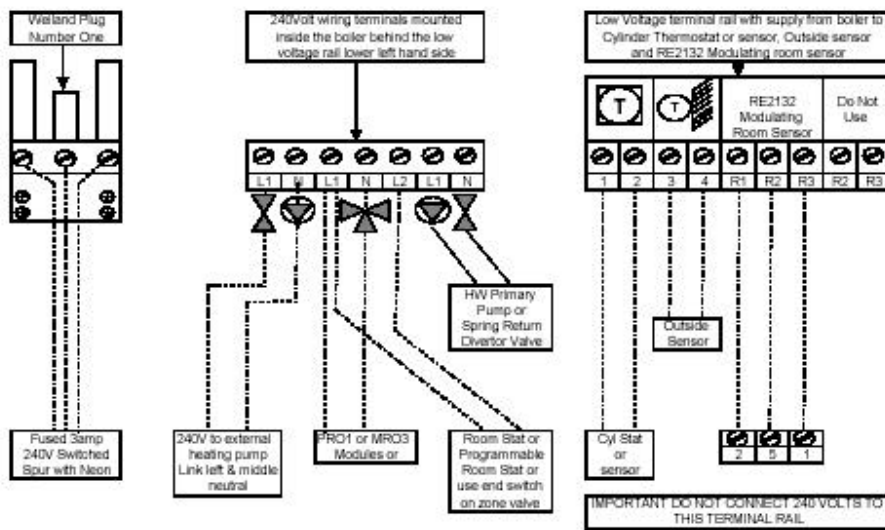

## 21. Electrical Connections

The boiler has a “Wieland” plug connector for connection to the mains as part of the wiring centre located at the bottom left hand side of the boiler.

Any external wiring to the boiler must be carried out in accordance with the IEE Wiring Regulations and any local regulations.



The Ethos 29cc is designed for 230 ~ 240v 50Hz single phase operation. The method of connection to the mains supply should allow for complete electrical isolation of the boiler, preferably by labelled double pole switched spur. The boiler must be protected by a 3 amp fuse. The point of connection to the mains should be readily accessible and adjacent to the boiler. If the boiler is to be sited in a bathroom the connection should be outside the room.

It is essential that the electrical supply in the property should be properly earthed in accordance with current IEE Wiring Regulations.

**Figure 28 Connecting to the Mains**

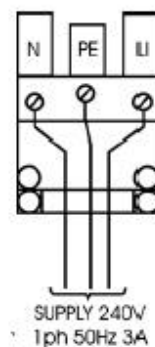

Using 3 core 1.5mm<sup>2</sup> cable connect the boiler to the mains electrical supply by passing the cable through the cable duct and connecting to the Wieland connector as shown in figure 28.

## 22. Heating Control Options

There are various methods of controlling the heating system from the boiler.

Using a regular room thermostat.

If a room thermostat is installed there must not be any thermostatic radiator valves on the radiator in that room.

Using a modulating room stat

With this special type of room thermostat, the boiler can be regulated in a modulating fashion. Please contact the Mikrofill technical department for more information.

If a room unit is installed there must not be any thermostatic radiator valves on the radiator in that room.

Using the built-in weather compensating control

This only requires an outside temperature sensor. **(Mounted on North facing wall)**

The integral boiler weather compensating controller is adjusted so the relationship between the outside temperature and the boilers flow temperature is sufficient to maintain the building temperature.

As the outside air temperature rises and falls a modulating control is achieved. Set up this way the temperature for the house is not controlled from one room, but on the basis of the outside temperature.

Using a regular room thermostat, it is also possible to change the relationship between the outside temperature and the supply temperature. Outside temperature is the preferred control if control from one room is not required or not possible. If outside temperature control is used, the radiators must be fitted with thermostatic valves.

### **22.1 240 Volt Connections**

The 240 volt terminal strip can be used to connect the following.

External pump(s) with a maximum of 500 Watt. This connection will supply external pump(s) when the boiler's integral pump is running.

A 240 Volt room thermostat.

Switch over three way valve (spring return type) or loading pump for the hot water cylinder.

Three way modulating mixing valve for a secondary circuit. The mixing valve and pump for this circuit has to be wired back to the control unit MR03 (available from Mikrofill) an additional pump greater than 500watts may also be connected

### **22.2 Low Voltage Connections**

The low voltage terminal strip can be used to connect the following.

Hot water cylinder sensor.

External temperature sensor.

RE2132 Modulating room sensor.

All of the above are available from Mikrofill

**NB** Do not connect 240 volts to the low voltage terminal strip.

### **22.3 Built-in clock**

The appliance has a unique built-in 3 channel programmable time clock. This enables not only the setting of the heating times for various temperatures, but also the heating times for hot water. During programmed off periods Combi models will maintain a minimum storage temperature of 40°C. For H and HS type appliances connected to hot water cylinder for this function to operate temperature control has to be provided with a sensor (available from Mikrofill). When hot water temperature control is provided by a cylinder thermostat this function is not recognised.

## 23. Boiler Control panel

**Figure 29 Boiler Control panel**

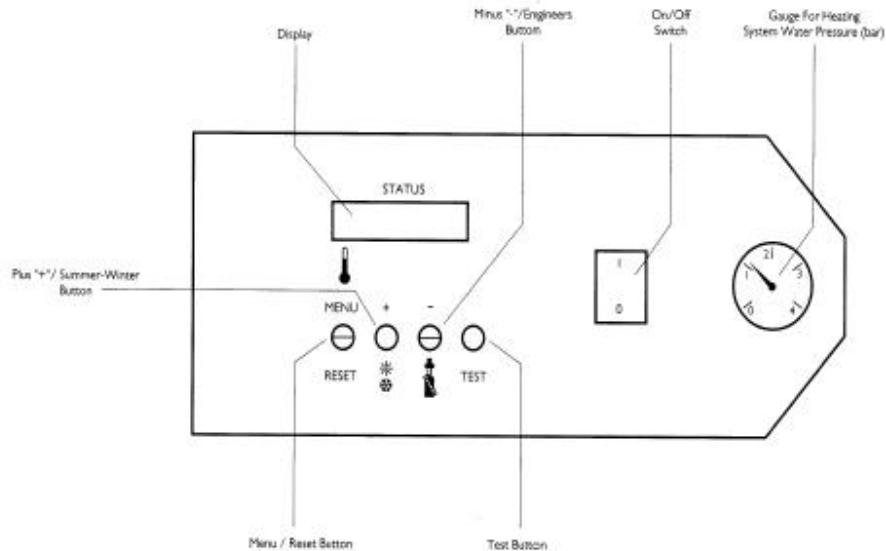

## 24. Boiler Control Panel

The boiler control panel incorporates the following features.

### 24.1 System water pressure gauge

Informs user of current system water pressure.

### 24.2 On / off switch Boiler isolating switch.

### 24.3 Lcd control display

The display has two lines: the upper line indicates the current operating status e.g HW DEMAND and either "S" (summer) or "W" (winter / "D" (day) or "n" (night).

b. the lower line indicates on the lefthand side the current boiler water temperature, and on the right-hand side the time.

If the button is pressed briefly, the following data may be viewed in the following order:

Press 1 T1 supply temperature in the system

Press 2 T3 tap water temperature

Press 3 T4 return temperature in the system

Press 4 T5 water, if connected, or the maintained temperature of the builtin tap water exchanger of the boiler

Press 5 T6 outside temperature

Press 6 Room 1 - heat demand value of connected room unit

Press 7 Speed 1 - fan speed





Press 8 Pump - % pump speed in relation to maximum

NB Only the values of connected components are shown.





#### 24.4 Menu - reset button

This button when pressed allows: Access to 3 layer menu programming options. Access to current boiler status displays. Confirms an entry when programming control. Reset the boiler after lockout. For meaning of lockout "FLASHING" display please refer to installer manual.

#### 24.5 Summer winter button

-  Advances (scrolls forwards through menu and programming options).
-  Increases a value in the LCD display.
-  Sets boiler control to either summer (hot water only) or winter (hot water and heating both on mode)
- 

#### 24.6 Engineers button

-  Reverses (scrolls backwards through menu and programming options).
-  Reduces a value in the LCD display.
-  Places appliance into engineers mode for servicing purposes.
-  "-" and "chimney sweep" symbols

The "-" button is used in combination with the menu button for programming purposes. The "chimney sweep" symbol (meant for the fitter).

Press once: The unit will operate continuously at 50%; sensors or room units will not switch it off, only the maximum control thermostat.

This mode is meant for measuring emissions (CO, CO, NOx).

Press twice: The unit can now operate at all loads, by pressing the "+" and "-" buttons if the menu button is also pressed seven times, the display will show the speed. This mode is used to set the gas valve, both at minimum and at maximum load.

#### 24.7 Test button

Checks overheat safety feature. When the burner is on and the button depressed, the burner will shut down when button released, the unit will startup again. . If the unit does not switch off, the wiring harness must be checked for short circuits, or the maximum thermostat must be replaced.

Checks pump function. When the burner is off and the button depressed, the pump will run at 100% speed for approx 2 seconds.

## 24.8 General

To access the programming mode for times, temperatures, etc., the "Menu" button must be depressed for **3 seconds** the screen will briefly display "MENU-" and display a menu option. Use the "+" and "-" buttons to scroll through the various options and the "MENU" button to select and confirm changes.

## 25. Menu options

### 25.1 Party/Extension Time

This function allows you to extend the current heating period. To access the party option press the "MENU-" button once and "\_\_\_\_hours" will flash on the screen, press "+" or "-" to enter a value then press "MENU-" button once to confirm entry. After expiry of the extension time set, the night-time temperature will start; if the lower night temperature had already started at the time of setting the party time, the daytime temperature will be obtained for the duration of the time set, after which the nighttime temperature will be resumed.

Range 0 – 24 hours. Default 0 hours.

## 26. User programming

### 26.1 Hot Water Temperature

This function allows you to select the maximum hot water temperature. For appliances connected to hot water cylinders where temperature control is provided with a sensor (available from Mikrofill) this function allows you to select the maximum temperature for the water in the cylinder. To access the "TEMP DHW" option press the "MENU" button until "\_\_\_\_" °C flashes on the screen. press "+" or "-" to enter a value then press "MENU-" button once to confirm entry. Temperature range 40- 60°C. Default 60°C.

### 26.2 Day temperature function

When the boiler is set up for outside temperature control (with or without a room thermostat or room unit) adjusting this setting raises or lowers the heating curve. This has the effect of increasing or lowering the boiler water temperature and ultimately increasing or lowering the room temperatures as the cooler or warmer water circulates through the heat emitters. Raising or lowering the building ambient temperature is possible without adjusting the setting of the room thermostat or room unit. If the boiler is set up to work without outside temperature reference then the feature has no function. To access press "MENU" button as before then press "+" or "-" to enter a value then press "MENU-" button once to confirm entry. The default value for this setting is 20°C

### 26.3 Time/day function

Having selected this function, there is a subprogram with two options:

the correct time, in minutes

To change the time press "MENU-" button once and then use the press "+" or "-" to change the time then press "MENU-" button once to confirm entry.

the day

To change the day press “-MENU-“ button once and then use the press “+” or “-“ to set the day then press “-MENU-“ button once to confirm entry.

#### **26.4 Setting the ch timer**

When a RE2132 room unit is fitted the built in timer function takes priority over the boiler's timer control. In this case the boiler timer should be set to 00.00 hours.

This programme enables the setting of 3 time blocks (3 start and 3 end times) per day (24 hours) for higher and lower room temperatures. This menu has two submenus:

- a. the days of the week
- b. the start and end times of each block

To access this function from the main menu display press “MENU” button for three seconds.

You will arrive at “PARTY O HOURS” in the display.

Press the “+” button three times to arrive at SET CH TIMER

Press the "MENU" button once and the first display will be "Monday" use the "+" and "-" buttons to scroll through this submenu to reach the day you want to change.

Having found the correct day, press the "MENU" button once to arrive at “CopySU>MO” ignore this and press the "+" button once to arrive at “SWITCH ON 1”  
“MO 00:00”

Press the "MENU" button once and the hours “00” part of the display will start flashing. This sets the hour the heating will start for the first of three possible on times per day. Adjust the hour by pressing the "+" and "-" buttons. When the correct time is displayed confirm by pressing "MENU" button once and the minutes part of the display “00” will start flashing.

Adjust the minutes by pressing the "+" and "-" buttons. When the correct time is displayed confirm by pressing "MENU" button once. Press the "+" button once to arrive at “SWITCH OFF 1” “MO 00:00”

This sets the hour the heating will switch off for the first of three possible off times per day.

Adjust the hour by pressing the "+" and "-" buttons. When the correct time is displayed confirm by pressing "MENU" button once and the minutes part of the display “00” will start flashing. Adjust the minutes by pressing the "+" and "-" buttons. When the correct time is displayed confirm by pressing "MENU" button once. Press the "+" button once to arrive at “SWITCH ON 2” “MO 00:00”

Repeat as above to programme all 3 start and 3 end times

**If you wish to ignore any periods then simply enter "0.00".**

Please note due to the nature of the pre-programmed boiler software there may be a half-hour delay in the CH system start and off times.

This period can be offset by adjusting the on and off times.

e.g. if you leave the house at 10:00 then enter 9:30 and if you are returning at 12:30 enter 12:00.

Always confirm the times with the "MENU" button.

Programming all periods - note: you may ignore any blocks by entering 00:00 with the exception of "SWITCH ON 1" and "SWITCH OFF 1" for which you must enter a real time. After you have programmed all three on and off periods press the "+" button to arrive at "<-BACK" Press the MENU button and you will arrive at TUESDAY.

Press the MENU button again and you will arrive at COPY "MO-> TU"

You can now copy the previous days program onto the next day e.g. Mondays times to Tuesday by pressing MENU or alternatively program in new times by pressing "+" button and repeating the process described in the previous section.

To copy the previous days program Press the "MENU" button, you arrive at:  
"MON -> TUESDAY"

Press the "MENU" button once to copy and the display will change to "WEDNESDAY".

Press the "MENU" button, you arrive at:

"TU -> WEDNESDAY"

Press the "MENU" button once to copy and the display will change to "THURSDAY"  
Repeat the process until all days have been copied or changed as required and you arrive at <- BACK.

To exit this second submenu, from <-BACK press "MENU" button once and you will arrive at SET HW TIMER

From here you can either continue to programme the unit or return to the operating display menu by pressing "+" repeatedly until you arrive at <-BACK then exit by pressing menu.

## **26.5 Setting the HW timer**

This programme enables the setting of 3 time blocks (3 start and 3 end times) per day (24 hours) for higher and lower temperatures of the supply of tap water.

This menu has two submenus:

a. the days of the week

b. the start and end times of each block

For programming, repeat as for section CH timer. During programmed off periods Combi models will maintain a minimum storage temperature of 46°C.

For appliances connected to hot water cylinder for this function to operate temperature control has to be provided with a sensor (available from Mikrofill). When hot water temperature control is provided by a cylinder thermostat this function is not recognised.

### **26.6 Setting MR03 times**

When a MR 03 secondary circuit control unit has been fitted then this programme enables the setting of 3 time blocks (3 start and 3 end times) per day (24 hours) for higher and lower temperatures for a second central heating circuit. Note unless a MR 03 is connected this function will not be seen.

### **26.7 Night-time lower 0oc.**

This is used to programme the value for the night time set back temperature in relation to the room temperature during the day.

NOTE ! If the difference between the daytime temperature and night time setback temperature is considerable, the start time of the central heating unit must be set earlier than required to compensate.

Statistically, it has been proven that a night time decrease of 5°C is best; if a lower night-time temperature is set, heating in the morning requires too much energy.

With "SETBACK" displayed on the screen press "MENU" button until "\_\_\_\_\_" °C flashes on the screen. press "+" or "-" to enter a value then press "-MENU-" button once to confirm entry.

### **26.8 Holiday function**

Use the "+" and "-" buttons to set the number of days of the holiday period.

During this period, the night time temperature will be maintained, while the tap water temperature will be set at a minimum of 20°C.

If you are away for an extended period then to save energy adjust the night time temperature to 10°C.

After the number of days has expired, the unit will start operating according to the clock programme set.

Remember when you return to re-adjust the night time temperature to it's original setting. Having completed the setting, press the "MENU" button to confirm the newvalue.



## 26.9 Installer

This function is for the service engineer only and is code protected.

The Main Menu contains the following sections:

**Table 12 Programming Options**

Programme Number	Programme Name	Setting Range
	- MENU -	
1	Party 0-24 hours	
2	Hot Water Temperature	40 - 60°C
3	Day Temperature 10 – 30°C	
4	Time / Day	Mon-Sun 0.00 – 24.00
5	Set Central Heating Timer	3 x time blocks
6	Set Hot Water Timer	3 x time blocks
7	Set Mixing Valve Timer	3 x time blocks
8	Night Setback Temperature 0- 10°C less than daytime	
9	Service In	365 Days
10	Holidays	0 – 99 days
11	Installer access code	21
12	Back	

## 27. Installer Programming

A number of programming options are provided for the installer. These can only be accessed and programmed by means of a code. If this code is entered (21) the following parameters can be changed:

**Table 13 Installer Functions**

Programme No.	Programme name	Setting range
1	Heating plan at +20°C outside temperature	0 - 40°C
2	Heating plan at -15°C outside temperature	10 - 85°C
3	* Minimum pump speed	20 - 50%
4	* Maximum pump speed	50 - 100%
5	Flow Temp at +20°C outside for secondary circuit	0 - 40°C
6	Service counter	0 - 1500 days
7	Pump continuous	0 or 1
8	ECO/ECO	
9	Post running of pump after hot water demand	0 – 5 minutes
10	Post running of pump after central heating demand	0 – 5 minutes
11	Minimum output Hot Water supply	20 – 50%
12	Maximum output Hot Water supply	20 – 100%
14	Maximum output Central Heating	20 – 83%

15	Function	
16		Back

\* can only be set if an outside temperature sensor has been installed.

\* can only be set if a modulating pump has been installed.

## **28. Outside Temperature Control**

The weather compensating factory settings are as figure 30 below.

## 28. Outside Temperature Control

The weather compensating factory settings are as figure 30 below.

**Figure 30 Weather Compensation**

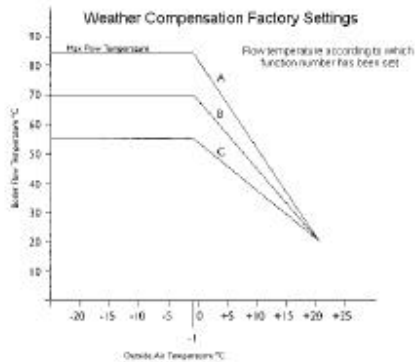

The flow temperatures are achieved by setting the required function number. See above. The relationship between flow temperature and outside temperature may be changed but the limiting factor will be the function number setting and corresponding flow temperature..

### 28.1 Flow Temperature at + 20°C

Setting the flow temperature when outside air temperature is + 20°C.

When control by outside air temperature is required the relationship between the outside temperature and the flow temperature can be changed. This line can be drawn between two points (-1°C and +20°C outside air temperature). Two temperatures, the flow temperature and the outside temperature define each point.

When the outside air temperature reaches 20°C then normally no heating would be necessary and the setting should be 20°C adjust if necessary.

Confirm by pressing the "MENU" button

**Figure 31 O/T Ctrl Flow temp 85°C.**

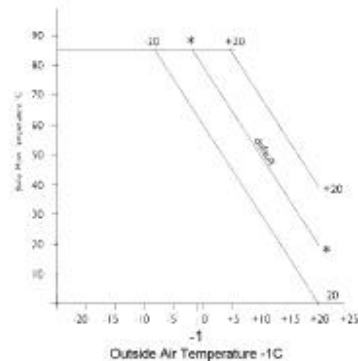

**Figure 32 O/T Ctrl Flow temp 70°C**

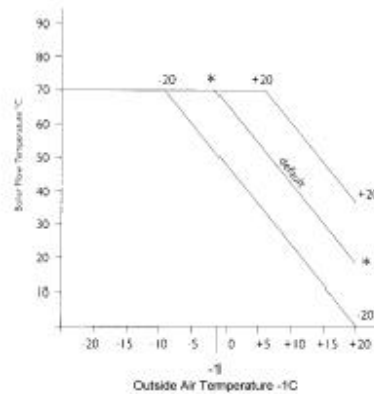

**Figure 33 O/T Ctrl Flow temp 50°C**

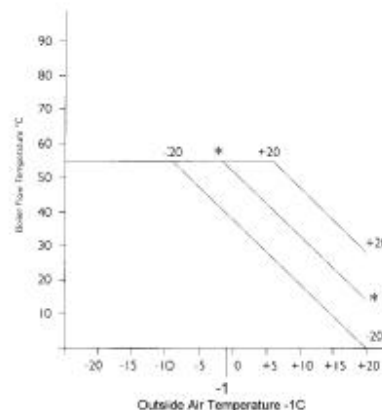

### **28.2 Outside Temp. Control at -1°C**

Setting the flow temperature when outside air temperature is -1°C

Enter here the flow temperature at -1°C outside temperature. The flow temperature is normally dependent on the size of the radiators and the calculated mean water temperature (generally 80°C). The limiting factor will be the function number setting. Confirm by pressing the "MENU" button.

The supply temperature will automatically adapt to any changes in the outside temperature in relation to this outside temperature.

### **28.3 Minimum pump speed**

If a modulating pump has been installed in the boiler, this function can be used to set the minimum pump speed. Normally, this value is 38%, but if the system resistance is high the minimum value must be set higher.

Use the "+" and "-" buttons to change the minimum percentage. Confirm by pressing the "MENU" button.

### **28.4 Maximum pump speed**

Normally the pump speed is 100%; if the water velocity or the noise from the radiators is too high, it is recommended to decrease the speed, taking into account the radiators that are furthest from the boiler must still maintain a sufficient flow.

### **28.5 Flow temperature secondary circuit**

When a secondary circuit control has been connected (MR 03 available from Mikrofill) to the boiler, the heating curve between the flow temperature of this circuit has to be set. Enter the required flow temperature when outside air temperature is +20°C, normally no heating would be necessary and the setting should be 20°C adjust if necessary. The flow temperature -1°C is set at the MR 03 control unit.

### **28.6 Service counter**

The boiler programme has a service counter, which is programmed at 365 days; after this period the message: "INSPECTION" appears. No other displays are shown until the fitter has reset the value of 365 days, or a different number of days, by pressing the "+" button. If necessary, this message can be removed from the system.

### **28.7 Pump continuous**

Pressing the "+" button will cause the pump to operate continuously, except if the Summertime Mode is selected. Pressing "-" indicates that a pump switch is present.

### **28.8 Eco/eco+**

If a modulating pump has been installed, the pump will modulate automatically in order to maintain the 20°C difference between the supply and return water temperatures. After heating in the morning, this modulation will only start after the desired supply temperature has been reached.

If the resistance in the system is high, it is often desirable to obtain a higher pump pressure: if "ECO" is selected, the pump will start modulating when a return temperature of 50°C or higher has been reached.

In the "ECO+" mode, the pump will modulate at any water temperature, with the exception of the heating cycle in the morning.

### 28.9 Post running of pump after HW

This function is used to set the post running time for the pump after the boiler has reached the required temperature. The default is 2 minutes, unless there is a demand from the CH system.

### 28.10 Post running of pump after CH

This function is used to set the post running time for the pump after the boiler has been switched off. The default is 1 minute.

### 28.11 Minimum DHW Capacity

Using this function the default setting can be changed. In certain locations at low fan speeds the influence of the wind across the flue terminal outlet can lead to flame lift. The minimum fan speed should be increased until burner pressure is equalised. This minimum is also the minimum output for central heating.

### 28.12 Maximum DHW Capacity

If the boiler starts to cycle during hot water production then a lower value could be set. However due to the boilers modulating control this is rarely necessary.

### 28.13 Maximum CH capacity

If the boiler starts to cycle when in heating mode then a lower value could be set. However due to the boilers modulating control this is rarely necessary.

### 28.14 Function Setting

**This "FUNCTION" number has to be set ALWAYS**

Outside temperature controlled without mixing circuit

Function No.	Room Temp Control	Max Flow Temperature
1	RE 2132	55°C
2	RE 2132	70°C
3	RE 2132	85°C
4	240v Room Stat	55°C
5	240v Room Stat	70°C
6	240v Room Stat	85°C
7	TRV's	55°C
8	TRV's	70°C
9	TRV's	85°C

Outside temperature controlled with mixing circuit

Function No.	Room Temp Control	Max Flow Temperature
--------------	-------------------	----------------------

10	With two RE 2132	70°C primary
11	With two RE 2132	85°C primary
12	With one RE 2132	70°C primary
13	With one RE 2132	85°C primary
14	240v Room Stat	70°C primary
15	240v Room Stat	85°C primary
16	TRV's	70°C primary
17	TRV's	85°C primary

Room temperature controlled without mixing valve

Function No.	Room Temp Control	Max Flow Temperature
18	RE 2132	55°C
19	RE 2132	70°C
20	RE 2132	85°C
21	240v Room Stat	55°C
22	240v Room Stat	70°C
23	240v Room Stat	85°C

Room temperature controlled with mixing valve

Function No.	Room Temp Control	Max Flow Temperature
24	With two RE 2132	70°C primary
25	With two RE 2132	85°C primary
26	With one RE 2132	70°C primary
27	With one RE 2132	85°C primary
28	240v Room Stat	70°C primary
29	240v Room Stat	85°C primary

Without room unit, thermostat or outside temperature control, constant flow temperatures without a mixing or secondary circuit.

Function No.	Room Temp Control	Max Flow Temperature
30	None	55°C
31	None	70°C
32	None	85°C

Without room unit, thermostat or outside temperature control, constant flow temperatures with a mixing or secondary circuit.

Function No.	Room Temp Control	Max Flow Temperature
33	None	70°C primary
34	None	85°C primary

Mikrofill cascade manager KKM2 Settings (for controlling up to nine boilers)

Function No.	Cascade manager	Max Flow Temperature
35	KKM2	CH temp on KKM2

Analogue cascade manager with signal 0...3 Volts.

Function No.	Cascade manager	Max Flow Temperature
36	Analogue 0...3 Volts	CH temp on manager

The following function numbers are valid when a **pump** is used to load the hot water cylinder

Outside temperature controlled without mixing circuit

Function No.	Room Temp Control	Max Flow Temperature
37	RE 2132	55°C
38	RE 2132	70°C
39	RE 2132	85°C
40	240v Room Stat 55°C	
41	240v Room Stat 70°C	
42	240v Room Stat 85°C	
TRV's		55°C
44	TRV's	70°C
45	TRV's	85°C 43

Outside temperature controlled with mixing circuit

Function No.	Room Temp Control	Max Flow Temperature
46	With two RE 2132	70°C primary
47	With two RE 2132	85°C primary
48	With one RE 2132	70°C primary
49	With one RE 2132	85°C primary
50	240v Room Stat 70°C	primary
51	240v Room Stat 85°C	primary
52	TRV's	70°C primary
53	TRV's	85°C primary

## Room temperature controlled without mixing valve

Function No.	Room Temp Control	Max Flow Temperature
54	RE 2132	55°C
55	RE 2132	70°C
56	RE 2132	85°C
57	240v Room Stat 55°C	
58	240v Room Stat 70°C	
59	240v Room Stat 85°C	

## Room temperature controlled with mixing valve

Function No.	Room Temp Control	Max Flow Temperature
60	With two RE 2132	70°C primary
61	With two RE 2132	85°C primary
62	With one RE 2132	70°C primary
63	With one RE 2132	85°C primary
64	240v Room Stat 70°C	primary
65	240v Room Stat 85°C	primary

Without room unit, thermostat or outside temperature control, constant flow temperatures without a mixing or secondary circuit.

Function No.	Room Temp Control	Max Flow Temperature
66	None	55°C
67	None	70°C
68	None	85°C

Without room unit, thermostat or outside temperature control, constant flow temperatures with a mixing or secondary circuit.

Function No.	Room Temp Control	Max Flow Temperature
69	None	70°C primary
70	None	85°C primary

## Mikrofill cascade manager KKM2 Settings (for controlling up to nine boilers)

Function No.	Cascade manager	Max Flow Temperature
71	KKM2	CH temp on KKM2



Analogue cascade manager with signal 0...3 Volts.

Function No.	Cascade manager	Max Flow Temperature
72	Analogue 0...3 Volts	CH temp on manager

**Figure 34 Internal Wiring**

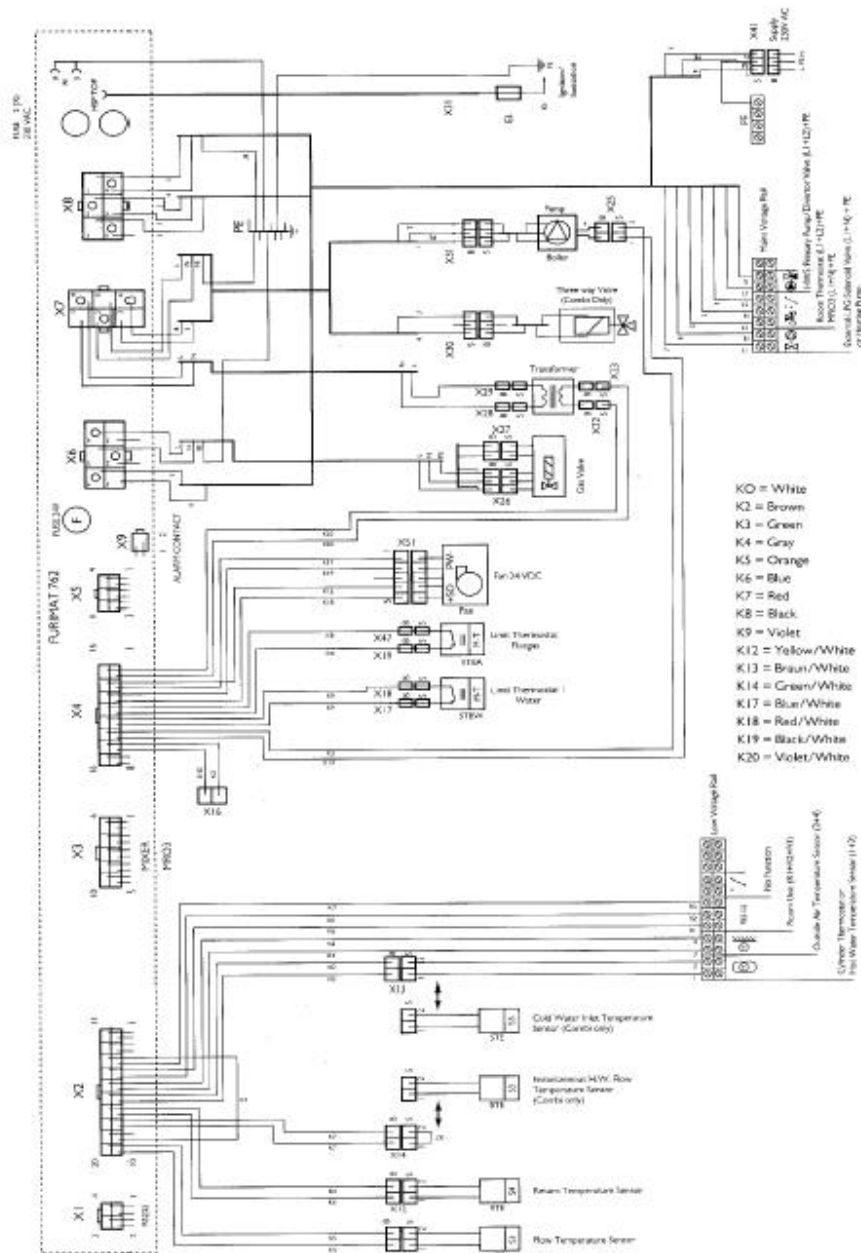

## **29. Commissioning**

### **29.1 Electrical Checks**

A "Preliminary Electrical System Check" should be carried out to ensure earth continuity, short circuit, polarity and resistance to earth using a suitable multi meter.

### **29.2 Gas Supply**

Check the gas installation and purge the supply in accordance with current Gas Safety Regulations.

The gas valve fitted to the boiler is not designed to withstand pressures in excess of 60 mbar. When carrying out the pressure test on the service pipework it is essential that the gas cock fitted to the boiler is in the closed position, failure to do so will result in serious damage to the boiler.

If using LPG, care should be taken to ensure that the storage tank has been correctly vented.

### **29.3 Connection to Pipe-work**

The boiler is a low water content unit. When connecting to an existing installation it is important that old system deposits are removed and are not allowed to contaminate the appliance.

### **29.4 Water Treatment**

In order to protect and prolong the working life of the appliance, it is important the general condition of older systems is carefully considered. The removal of debris, flux residue, grease, metal swarf etc. from new systems and any rust, black magnetic iron oxide sludge and lime-scale from old systems is essential.

Consider high pressure flushing to remove all debris in badly contaminated systems.

Fit in-line filters for full protection. All installations should be treated and maintained with Fernox MB1 at a concentration of 4%.

### **29.5 Flushing System Pipe-work**

Before the final flow and return connections are made to the boiler, the system must be thoroughly flushed. Ensure that all radiator valves are open. Flush the system with clean water until the discharge runs clear. Make good final connections to boiler.

### **29.6 Filling and Venting the System**

Using a suitably approved filling loop connected to the incoming mains cold water supply, fill the system. The correct filling pressure is between 1 and 2 bar. Depending on the type of unit, the following steps must be completed:

Venting is achieved automatically after switching on the appliance or after a reset. The boiler control has a special start-up programme for venting the unit.

This programme is started when the unit is powered for the first time and there is a heat demand present. This start-up venting programme takes 1 minute to complete.

This feature however does not remove the need for traditional venting techniques and the following venting procedure should be completed in all cases.

The boiler has a manual bleed valve located on the top right hand side along with a short piece of clear plastic hose. Open the manual bleed valve and run water into hose pipe until air bubbles stop.

All the air should be vented via this point.

If necessary, this bleeder can be replaced with an automatic air vent.

Check the filling pressure of the unit shortly after startup, add water if necessary in order to maintain the correct pressure.

Filling is only complete when the boiler and the heating system are completely vented.

The heating system should be fitted with manual air vents at all high points.

Check for water soundness at design operating temperature.

After commissioning, the system should be thoroughly flushed whilst system water is still warm.

Drain down system and make good to any leaks.

Refill, add a suitable corrosion inhibitor Fernox MB 1 at 4%.

For further information about filling the system contact the Mikrofill Technical Support Department.

### **30. Combustion Ratio**

Due to the precise Variable Controlled Output of the boiler it is highly recommended that flue gas analysis equipment be used when setting up the burner.

The setting up of the boiler using gas pressures should be used as a temporary or emergency measure only.

#### **30.1 Commissioning NG and LPG**

Measure the standing gas pressure at the measuring nipple on the gas valve. This should be done at test point (32) on the gas valve (see figure 35). Nominal pressure should be 20 mbar in the case of natural gas, and 37 mbar in the case of propane gas. Turn up the boiler controls to call for heat. Switch on the boiler, if the boiler fails to start check the LCD display for a flashing [FAULT CODE], if this occurs turn the adjusting screw (31) in the centre of the gas valve ½ a turn to the right and press the reset button. The boiler should now fire.

After the boiler has fired and ran for five minutes press the flue emissions button with the chimney sweep icon twice. The status display will show the [partial load]. Using the "+" or "-" button, the fan speed can be increased or decreased.

Keep pressing the "MENU" button until the fan speed is shown.

To obtain the minimum load, press the "-" button until the minimum speed has been obtained.

To obtain the maximum load, press the "+" button until the maximum speed has been obtained.

If measuring is done for more than 10 minutes, the unit will return to automatic mode; press the chimney sweep button twice again for subsequent measurements

**Table 14 Minimum and Maximum Speeds**

Unit 16		23	31	38
Min	900	900	900	1050
Max	6000	6000	6000	7500

### 31. Setting the Maximum CO<sub>2</sub> Value

Press the flue emissions button with the chimney sweep icon twice.

To obtain the maximum load, press the "+" button until the maximum fan speed has been obtained. (See table 14).

The boiler will now operate at 100% output for approximately 10 minutes.

From the measuring point located at the top right hand corner of the heat exchanger remove the plastic sealing nut and fibre washer. Insert the probe of the gas analyser 2cm into the heat exchanger and measure the CO<sub>2</sub> level. The burner will have a red surface. If necessary fine tune using the adjusting screw 4 Q Max until the required CO<sub>2</sub> (see table 15) value is reached. Turn the screw clockwise to lower the CO<sub>2</sub> reading and anti clockwise to increase the CO<sub>2</sub>.

**Remember to allow 2 minutes for the analyser to respond to any adjustments.**

Figure 35 Gas valve adjustments

To obtain the minimum load, press the "-" button until the minimum speed has been obtained

Measure the CO<sub>2</sub> level. (This reading should be 9.2% for NG and 11.0 for LPG). The colour of the flame should be red/blue with small sharp cones and without any flame lifting. If necessary fine tune using the adjusting screw 3 Q Min until the CO<sub>2</sub> value is reached. Turn the screw anti clockwise to lower the CO<sub>2</sub> reading and clockwise to increase the CO<sub>2</sub>.

**Remember to allow 2 minutes for the analyser to respond to any adjustments.**

**Table 15 CO<sub>2</sub> Outputs**

Gas Type	Natural	LPG
Injector Dia. Min	None	5.7mm
Wo (MJ/m <sup>3</sup> )	15.0	24.3

CO <sub>2</sub> % partial load	9.0 – 9.5	11.5 – 12.0
CO <sub>2</sub> % full load	8.5 – 8.8	15.5 – 11.0
CO ppm partial load	<15	<20
CO ppm full load	<50	<150

The measured CO<sub>2</sub> and CO values are for partial load (20%) and full load (100%) with the casing removed. When the setting is correct press the flue emissions test button once and the boiler will revert to normal operation.

### 31.1 Flue System Check

In order to examine the flue pipe sealing it is essential that an O<sub>2</sub> or CO<sub>2</sub> reading is taken from the 8mm plastic pipe that should be positioned from the Grey Vent/Flue adapter led down and through the bottom boiler plate.

The flue seal is satisfactory when the CO<sub>2</sub> value is no more than 0.2% and the O<sub>2</sub> value no more than 20.6%

### 31.2 STB Test Button (Green).

This button is used to test the correct operation of the overheat thermostat (high limit thermostat).

## 32. Diagnostics

### 32.1 Control panel

The control panel of the unit has a LCD screen displaying two lines of data. This screen provides information about the operation of the boiler it displays operation messages (non-flashing) and fault messages (flashing display).

The first line contains textual information on the operating status of the unit. It shows:

**Table 16 – LCD Display**

IDLE	This display shows that there is no heat demand
CH OPERATION	The boiler is operating in central heating mode
TAP WATER OPERATION	The boiler is operating to produce DHW
10MIN. PARTIAL LOAD	The boiler is operating in chimney sweep mode for 10 minutes

In the following cases, there may be a heat demand, but the burner is not working, for one of the following reasons:

**Table 17 LCD 'Non Flashing'- burner off  
Status Display messages 'Non Flashing' with the burner off**

MAXIMUM WATER TEMP	The boiler water temperature has reached the set point
FAN OFF-ON	The fan has switched off. Unit will try to reset automatically.
FAN TOO LOW	Detected fan speed to low. Unit will try to reset automatically. Check wiring terminals on top of transformer
FLAME IDENTIFICATION	Flame detected. . Unit will try to reset automatically.
BLEED	Boiler going through automatic venting cycle

### 33. Fault Finding.

Fault Indicator (flashing display)

To a certain extent the boiler will attempt to automatically overcome some of the faults that occur.

For example, it will attempt 4 ignition sequences before going to lock out.

In situations where it has not been successful, the boiler will lock out and can only be re started by pressing the manual (Red) reset button.

When in lock out mode, the error is displayed in the LCD display as a flashing message.

The following list indicates the messages shown and the descriptions of the faults. The numbers shown in the left hand column suggest the possible cause.

By using the numbered lists attached, the cause of the fault can be quickly identified and a repair effected.

**Table 18 Fault Display Flashing**

Display message	Type of fault	Check table row number
FLASHING		
STB- supply	Maximum flow temperature has been reached	2,4,5,21,23,24,29,30
STB- fluegas	Maximum flue gas temperature has been reached	4,5,23,24,29,33
Fanspd high	Fan speed is too high	7,8,9,39,40
Fanspd low	Fan speed is too low	7,8,9,39,40
Ignit fault	No flame after 4 attempts	10,11,16,18,22,25
No flame	Flame failed during operation	11,12,16,22,25,26,32,44
False flame	False flame detection	18,35
S1 disconnect	Sensor or cable interrupted	3,41,42,43
S3 disconnect	Sensor or cable interrupted	3,41,42,43
S4 disconnect	Sensor or cable interrupted	3,41,42,43
S7 disconnect	Sensor or cable interrupted	3,41,42,43
Program end	Sensor or cable interrupted	3,41,42,43
Gasvalve	No phase connection for gas valve	34,20

Softw Fault	A software error has occurred	34
Reset-Key	Reset button is stuck	34
Eeprom	EEPROM test failed	34
Intern fault		
Test fault		

In addition, there is a number of faults that cannot be reported by means of a textual display:

**Table 19 Non Display Faults and Errors**

water inside casing	leak
load is too low discharge resistance	Fan speed
CO-content is too high	bad combustion
CO2 % is too low	too little gas or too much air
CO2 % is too high	too much gas
tap water temperature too low	leaking three-way valve
to little tap water	blockage, lime scale deposit
no CH operation	leaking hot water pipe or dripping tap
Display has illegible text	moisture problems in unit controller, or an incorrect ignition plug used on the electrode
Water pressure constantly low	leak in system, or internal leak in expansion vessel

**Table 20 Reasons for Error Display**

	Fault	Suggested Remedy
1	room thermostat connected incorrectly	check or replace cable
2	room thermostat fails to switch off	Replace room thermostat or replace cable
3	Relevant sensor short-circuits in cable or internally	Replace sensor or identify fault in cable
4	Pump not running; or sticks	Try to release pump shaft or replace pump power unit
5	Water pressure in CH installation is too low	Top up water and find leak, also check for internal leak in expansion vessel
6	Water pressure in CH installation is too high	Too much water added, check expansion vessel pressure, or replace expansion vessel
7	Fan not connected (plug not inserted)	Install connector
8	Fan is contaminated or dirty	Clean fan blades
9	Fan is defective	Replace fan
10	Gas tap has not been opened	Open gas tap
11	Gas pressure is too low	Check pipes and gas meter
12	Diameter gas pipe is insufficient	Modify gas pipe

13	Fuse A1 defective	Replace fuse
14	Fuse A2 defective	Replace fuse
15	Fuse A3 defective	Replace fuse
16	Gas valve setting high/low incorrect	Set up gas valve with gas analyser
17	Gas valve has no or incorrect electrical connection	Use the wiring diagram to check the wiring, check the gas valve connection, check for any moisture
18	Ignition cable not connected correctly	Check cable for short circuit, overheating, too close to or crushed by casing
19	Transformer defective	Replace transformer
20	Connector to gas valve not connected, or moisture inclusion	Moisture inclusion, check the cable sockets, which must be inserted into connectors properly, check position of the cable socket, set if necessary, before moving connector
21	Pump connector not connected correctly	Check whether the connector(s) fit together properly, with the appropriate pressure
22	Syphon blocked	Open the flushing pipe (bottom left of the back panel) by taking the cap off. Hold a bowl underneath to collect any water that may escape. Pinch pipes to both to the upper left and the upper right. Rinse syphon trap. If necessary, take the burner unit from the unit and pour water into the heat exchanger to rinse the syphon.
23	Open and close manual bleed valve after bleeding	Bleed and vent as required
24	Three-way valve contaminated	Isolate and drain boiler water. Disassemble the three-way valve by tilting the mounting springs 90°. Remove the motor by pulling the hairpin spring from the house and inspect the three connecting feet of the three-way valve.
25	Too much resistance in the flue system or flue system blocked	Check the supply and discharge pipes for blockages

26	Flue system leaks into the air supply system or re-circulation of flue gases in concentric flue	Check the air supply and flue system
27	Supply system leaks in	See 26
28	Flow limiter is contaminated	Remove the cold-water connection from the unit,



		remove the flow limiter and clean it
29	Heat exchanger is blocked	Remove the heat exchanger from the unit by releasing the mounting springs (2) and the clamp at the front. Use pressurised air to blow the exchanger clean; if necessary, rinse with a slightly (10%) hydrochloric acid solution
30	High limit thermostat defective	Replace the maximum thermostat
31	Maximum load is too high	Check the minimum setting of the unit and the nozzle for a proper diameter.
32	Incorrect nozzle	Replace by correct nozzle
33	Flue gas thermostat defective	Replace
34	Controller defective	Replace entire boiler control box
35	Ignition electrode incorrect	Replace
36	Moisture on gas valve cables	Dry, if necessary using hot air (hair dryer) and check for proper functioning; replace if necessary
37	Moisture on electronics box	See 36
38	Moisture in pump wiring	See 36
39	Moisture on fan or and/or connections	Remove the connection and dry by blowing or using hair dryer
40	Fan connector incorrectly connected	Connector must point in the direction of the outside of the ventilator and one side must fit into the slot in the printed circuit
41	Connector incorrectly connected	Check connectors and fit into one another properly
42	Cable damaged	Check cables for possible damage or kinks
43	Sensor defective	Check cable pipe connections
44	Flue gas re-circulation from behind heat exchanger	Check heat exchanger seal on flue gas box, replace if necessary.

## **34. Handing the boiler over**

### **34.1 Customer Familiarisation**

Before leaving the installation, it is important to familiarise the customer with the operating principles of the boiler. Their attention should also be drawn to the safety precautions. Familiarise the customer with the control panel layout.

### **35. Annual Servicing**

It is a condition of the boiler warranty that all servicing and maintenance be carried out annually by Mikrofill approved engineers only. When the word [SERVICE] is displayed in the LCD display on the control panel, a full service of the unit is required.

A service has to be carried out when:

The appliance tells so by the LCD that inspection is needed;

Every 12 months

Before maintenance is started the appliance has to be inspected.

### **35.1 Service Inspection**

The following is the Mikrofill approved service schedule:

Interview with the user about possible problems or complaints with the appliance or its use. The remarks of the user should be taken seriously and the reason for any complaints or anomalies should be found and rectified.

Check the water pressure of the system. System pressure of the installation should be between 1 and 2 bar; any cause for pressure loss should be found and rectified.

Lift the casing of the boiler and inspect all pipes for water leaks or water damage. Sweating joints or leaks should be repaired immediately.

Inspect the top of the boiler for water-leak or traces or evidence of water leaking from the 125mm air inlet tube or the automatic air separator. The cause of any water or moisture entering the boiler through the 125mm airinlet tube should be found and rectified. Check the air and flue duct for proper alignment, and the air and flue duct terminal. Set the appliance burning at maximum output and measure the CO . Adjust the maximum setting of the gas valve as required. Set the appliance burning at medium output and measure the CO<sub>2</sub>. Adjust the setting of the gas valve as required. Pay attention to the sound of the circulator. Check for air in the shaft and vent if required.

If the flow rate is less than 9 litres/min check the mains cold water supply. If the mains pressure is not the cause, the flow restrictor needs to be checked for blockages. If the flow restrictor is clean then there could be calcium in the AQUABOOSTER. The AQUABOOSTER needs to be replaced. Due to its construction, cleaning of the heat exchanger is not possible, one might think it is, but experience has shown that after cleaning, the lifetime of the component is very short, making cleaning uneconomical. Check, during hot water supply, the temperature of the flow to the central heating

system. If during the hot water cycle the flow to the c/h system goes up in temperature, this indicates that the three-way valve has an internal leak and needs to be cleaned. The boiler needs to be drained and the three-way valve can be dismantled. Remove the ignition cable and then disconnect the fan. Take off the burner by removing 6 x M6 nuts. Check the inside of the heat exchanger, look for any irregularities. When the main heat exchanger has dirt on the inside of the elements, clean with a hard brush (no steel), or with lemon acid. Afterwards use a vacuum cleaner to remove all the dirt. **The burner itself should never be cleaned.**

When the condensate water out of the cleaning tube of the syphon is dirty, the syphon requires cleaning.

Rinse the syphon through the syphon flush connection or with the burner dismantled flush cold water through the syphon heat exchanger connection or with access to the flue, flush the heat exchanger and syphon through by pouring water down the 70mm inner flue duct.

After flushing ensure that the condensate syphon is refilled with water, otherwise flue products may be passed through the condensate pipework into the building.

Take off the plastic mixing box at the inlet side of the fan, inspect the fan impeller for damage. When the impeller of the fan is dirty every blade has to be carefully cleaned until the original plastic material is clearly visible.

When dirt is left on the blades the fan will run out of balance and, due to the fast fan speeds (>6000 rpm), additional and unnecessary loads will be placed on the fan bearings significantly reducing the lifetime of the component.

Check the distance of the electrode to the burner; this should be a 3mm ~ 4mm gap. Bend the electrode, without touching the burner surface, very carefully until a space of 3mm ~ 4mm is achieved.

Check the seals on the gas connections and ensure that the gas service is sound by completing a gas soundness test.

Check the wiring and fuse at the spur is no greater than 3amp.

### **35.3 Service records**

Complete the appliance service record, ask the user to sign it and hand them the second copy. Return the top copy to Mikrofill and service company or service engineer to retain copy on file for their/your records.

Complete an appliance service label and attach to underside of appliance case.

### **36. Decommissioning the boiler**

When decommissioning the boiler, precautions should be taken to avoid frost damage. Therefore it is essential that both the boiler and the central heating system are completely drained down.

To do this remove the front casing and connect a hose to the central heating drain point. The system should be vented by opening the DHW valve and /or the manual air vent on the central heating circuit.

Tag the boiler “DO NOT USE- SYSTEM DRAINED” and remove the fuse at the isolating switch.

## **37. User Instructions**

### **37.1 Annual Servicing.**

It is a condition of the boiler warranty that all servicing and maintenance be carried out annually by Mikrofill approved engineers only.

When the word [INSPECTION] is displayed in the LCD display on the control panel, a full service of the unit is required.

A service has to be carried out when:

The status display appears INSPECTION  
or

Every 12 months

### **37.2 Decommissioning the boiler.**

When decommissioning the boiler, precautions should be taken to avoid frost damage. Therefore it is essential that both the boiler and the central heating system are completely drained down. 37.3 Built-in clock the appliance has a unique built-in three channel programmable time clock. This enables not only the setting of the heating times for various temperatures, but also the heating times for hot water. During programmed off periods Combi models will maintain a minimum storage temperature of 40°C. For H and HS type appliances connected to hot water cylinder for this function to operate temperature control has to be provided with a sensor (available from Mikrofill). When hot water temperature control is provided by a cylinder thermostat this function is not available. For convenience it is possible to ignore the built in programmer and alternatively control the boiler using a remote programmer. Please check with your installer to confirm which option has been installed.

**Figure 36 Boiler Control panel**

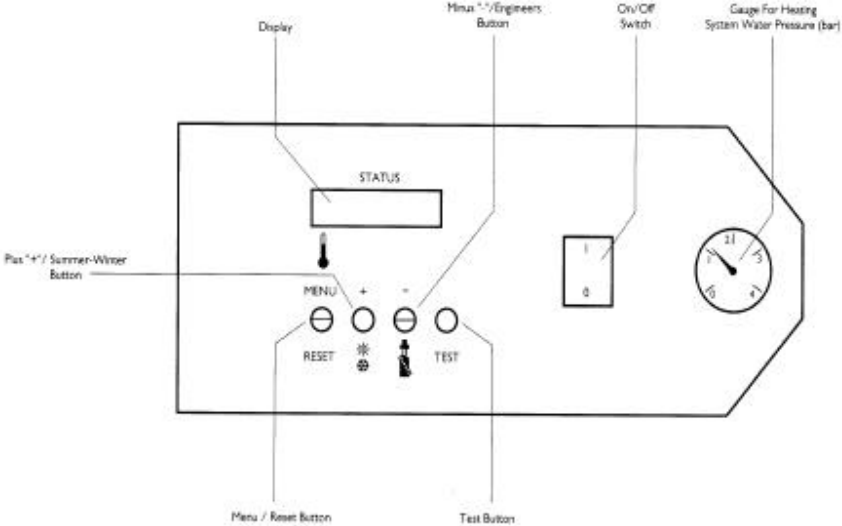

### **37.4 Boiler Control Panel**

The boiler control panel incorporates the following features.

### **37.5 System water pressure**

Informs user of current system water pressure.

### **37.6 On / off switch**

Boiler isolating switch.

**Always switch to the OFF position when working on the unit.**

### **37.7 Lcd control display**

The display has two lines:

the upper line indicates the current operating status e.g. HW DEMAND and either "S" (summer) or "W" (winter / "D" (day) or "n" (night).

b. the lower line indicates on the lefthand side the current boiler water temperature, and on the right-hand side the time.

If the button is pressed briefly, the following data may be viewed in the following order:

Press 1 x T1 supply temperature in the system

Press 2 x T3 tap water temperature

Press 3 x T4 return temperature in the system

Press 4 x T5 water, if connected, or the maintained temperature of the built-in tap water exchanger of the boiler

Press 5 x T6 outside temperature

Press 6 x Room 1 - heat demand value of connected room unit

Press 7 x Speed 1 - fan speed

Press 8 x Pump - % pump speed in relation to maximum

Only the values of connected components are shown.

### **37.8 Menu - reset button**

A pressure operated switch activated by pressing with finger until sensor below casing facia clicks or display changes. This button when pressed allows:

Access to three layer menu-programming options.



Access to current boiler status displays.

Confirms an entry when programming control.



Reset the boiler after lockout.

For meaning of lockout "FLASHING" display please refer to installer manual.

### 37.9 Summer winter button

- + Advances (scrolls forwards through menu and programming options).
-  Increases a value in the LCD display.
-  Sets boiler control to either summer (hot water only) or winter (hot water and heating both on mode)

### 37.10 Engineers button

- Reverses (scrolls backwards through menu and programming options).
-  Reduces a value in the LCD display.
-  Places appliance into engineer's mode for servicing purposes.

### 37.11 Test button

Checks overheat safety feature. When the burner is on and the button depressed, the burner will shut down when button released, the unit will start up again.

Checks pump function. When the burner is off and the button depressed, the pump will run at 100% speed for approx 2 seconds.

### 37.12 General

To access the programming mode for times, temperatures, etc., the "Menu" button must be depressed for **3 seconds** the screen will briefly display "-MENU-" and display a menu option. Use the "+" and "-" buttons to scroll through the various options and the "MENU" button to select and confirm changes.

## 38. Programming Menu options

### 38.1 Party

This function allows you to extend the current heating period. To access the party option press the "-MENU-" button once and "\_\_\_\_hours" will flash on the screen, press "+" or "-" to enter a value then press "-MENU-" button once to confirm entry.

After expiry of the extension time set, the nighttime temperature will start; if the lower night temperature had already started at the time of setting the party time, the daytime temperature will be obtained for the duration of the time set, after which the nighttime temperature will be resumed.

Range 0 – 24 hours. Default 0 hours.

### 38.2 Hot Water Temperature

For S type appliances (COMBIS) this function allows you to select the maximum hot water temperature. For H and HS type appliances connected to hot water cylinder where temperature control is provided with a sensor (available from Mikrofill) this function allows you to select the maximum temperature for the water in the cylinder.

To access the "TEMP DHW" option press the "MENU" button until "\_\_\_\_" °C flashes on the screen. press "+" or "-" to enter a value then press "-MENU-" button once to confirm entry.

Temperature range 40 - 60°C. Default 60°C.

### 38.3 Day temperature function

When the boiler is set up for outside temperature control (with or without a room thermostat or room unit) adjusting this setting raises or lowers the heating curve.

This has the effect of increasing or lowering the boiler water temperature and ultimately increasing or lowering the room temperatures as the cooler or warmer water circulates through the heat emitters.

Raising or lowering the building ambient temperature is possible without adjusting the setting of the room thermostat or room unit. If the boiler is set up to work without outside temperature reference then the feature has no function. To access press "MENU" button as before then press "+" or "-" to enter a value then press "-MENU-" button once to confirm entry. The default value for this setting is 20C

#### **8.4 Time/day function**

Having selected this function, there is a subprogram with two options: the correct time, in minutes To change the time press "-MENU-" button once and the use the press "+" or "-" to change the time then press "-MENU-" button once to confirm entry. the day To change the day press "-MENU-" button once and the use the press "+" or "-" to set the day then press "-MENU-" button once to confirm entry.

#### **38.5 Setting the ch timer**

When a RE2132 room unit is fitted the built in timer function takes priority over the boilers timer control. In this case the boiler timer should be set to 00.00 hours. This programme enables the setting of 3 time blocks (3 start and 3 end times) per day (24 hours) for higher and lower room temperatures. This menu has two submenus: a. the days of the week b. the start and end times of each block To access this function from the main menu display press "MENU" button for three seconds. You will arrive at "PARTY O HOURS" in the display. Press the "+" button three times to arrive at SET CH TIMER Press the "MENU" button once and the first display will be "Monday" use the "+" and "-" buttons to scroll through this submenu to reach the day you want to change. Having found the correct day, press the "MENU" button once to arrive at "CopySU>MO" ignore this and press the "+" button once to arrive at "SWITCH ON 1" "MO 00:00"

Press the "MENU" button once and the hours "00" part of the display will start flashing. This sets the hour the heating will start for the first of three possible on times per day Adjust the hour by pressing the "+" and "-" buttons. When the correct time is displayed confirm by pressing "MENU" button once and the minutes part of the display "00" will start flashing.

Adjust the minutes by pressing the "+" and "-" buttons. When the correct time is displayed confirm by pressing "MENU" button once. Press the "+" button once to arrive at "SWITCH OFF 1" "MO 00:00"

This sets the hour the heating will switch off for the first of three possible off times per day.

Adjust the hour by pressing the "+" and "-" buttons.

When the correct time is displayed confirm by pressing "MENU" button once and the minutes part of the display "00" will start flashing.

Adjust the minutes by pressing the "+" and "-" buttons. When the correct time is displayed confirm by pressing "MENU" button once.

Press the "+" button once to arrive at

"SWITCH ON 2" "MO 00:00"

Repeat as above to programme all 3 start and 3 end times

**If you wish to ignore any periods then simply enter "0.00".**



Please note due to the nature of the pre-programmed boiler software there may be a half-hour delay in the CH system start and off times.

This period can be offset by adjusting the on and off times.

e.g. if you leave the house at 10:00 then enter 9:30 and if you are returning at 12:30 enter 12:00.

Always confirm the times with the "MENU" button.

Programming all periods - note: you may ignore any blocks by entering 00:00 with the exception of "SWITCH ON 1" and "SWITCH OFF 1" for which you must enter a real time.

After you have programmed all three on and off periods press the "+" button to arrive at "<-BACK" Press the MENU button and you will arrive at TUESDAY. Press the MENU button again and you will arrive at COPY "MO-> TU" You can now copy the previous days program onto the next day e.g. Mondays times to Tuesday by pressing MENU or alternatively program in new times by pressing "+" button and repeating the process described in the previous section. To copy the previous days program Press the "MENU" button, you arrive at: "MON -> TUESDAY" Press the "MENU" button once to copy and the display will change to "WEDNESDAY". Press the "MENU" button, you arrive at: "TU-> WEDNESDAY" Press the "MENU" button once to copy and the display will change to "THURSDAY" Repeat the process until all days have been copied or changed as required and you arrive at <- BACK. To exit this second submenu, from <-BACK press "MENU" button once and you will arrive at SET HW TIMER From here you can either continue to programme the unit or return to the operating display menu by pressing "+" repeatedly until you arrive at <-BACK then exit by pressing menu.

### **38.6 Setting the hw timer**

This programme enables the setting of 3 time blocks (3 start and 3 end times) per day (24 hours) for higher and lower temperatures of the supply of tap water. This menu has two submenus: a. the days of the week b. the start and end times of each block

For programming, repeat as for section CH timer.

During programmed off periods Combi models ('S' types) will maintain a minimum storage temperature of 40°C.

For H and HS type appliances connected to hot water cylinder for this function to operate temperature control has to be provided with a sensor (available from Mikrofill). When a cylinder thermostat provides hot water temperature control this function is not recognised.

### **38.7 Setting times**

When a secondary circuit control unit has been fitted then this programme enables the setting of 3 time blocks (3 start and 3 end times) per day (24 hours) for higher and lower temperatures for a second central heating circuit. Note unless a MR 03 is connected this function will not be seen.

### **38.8 Night-time setback**

This is used to programme the value for the night time set back temperature in relation to the room temperature during the day.

NOTE! If the difference between the daytime temperature and night time setback temperature is considerable, the start time of the central heating unit must be set earlier than required to compensate.

Statistically, it has been proven that a night time decrease of 5°C is best; if a lower night time temperature is set, heating in the morning requires too much energy.

With "SETBACK" displayed on the screen press "MENU" button until "\_\_\_\_\_" °C flashes on the screen. press "+" or "-" to enter a value then press "-MENU-" button once to confirm entry.

### **38.9 Holiday function**

Use the "+" and "-" buttons to set the number of days of the holiday period.

During this period, the night time temperature will be maintained, while the tap water temperature will be set at a minimum of 20°C.

If you are away for an extended period then to save energy adjust the night time temperature to 10°C.

After the number of days has expired, the unit will start operating according to the clock programme set.

Remember when you return to re-adjust the night time temperature to it's original setting. Having completed the setting, press the "MENU" button to confirm the new value.

### **38.10 Installer**

This function is for the service engineer only and is code protected.

Mikrofill Systems Limited  
West Court  
Buntsford Park Road  
Bromsgrove  
B60 3DX

Tel: 01527 574574

Fax: 01527 575565

e-mail: [info@mikrofill.com](mailto:info@mikrofill.com)

WWW – [www.mikrofill.com](http://www.mikrofill.com)