

# Slant/Fin® LYNX



This manual must be left with owner and should be hung on or adjacent to the boiler for reference.

## DIRECT-VENT SEALED COMBUSTION CONDENSING BOILER HOT WATER MODEL LX-90, LX-120 & LX-150 GAS-FIRED BOILERS FOR NATURAL AND L.P. PROPANE GASES

# INSTALLATION AND OPERATING INSTRUCTIONS

### TABLE OF CONTENTS

Dimensions, Rating and Orifice Sizes .....2  
 Identification of Parts .....3  
 Installation Requirements .....4  
 Contamination Prevention.....5  
 Mounting the boiler on a wall.....6  
 Venting Application .....6  
 Boiler Room Air Supply and Ventilation.....6  
 Flue Gas Venting Requirements.....7  
 Additional Installation Requirements for Massachusetts .....7  
 Vent and Air Intake Material .....8  
 PVC/CPVC Pipe General Assembly Method.....8  
 Vent and Air Intake Restrictions .....8  
 Sidewall Venting, Non-Direct Vent .....10  
 Vent Termination Location and Clearance.....10  
 Non-Direct Vent Installation .....10  
 Direct Vent Installation .....10  
 Sidewall Venting, Direct Vent .....10  
 Vent/Air Intake Termination Installation.....16  
 Direct Vent, Venting and Air Intake through a Roof .....17  
 Venting and Air Intake Regular Inspection .....18  
 Condensate Removal System .....18  
 Gas Piping .....18  
 Electrical Wiring .....19  
 Wiring Diagram .....20  
 Single and Multi Zoning .....22  
 Water Piping .....24  
 Operating Instructions.....30  
 Boiler Control and Display .....30  
 Boiler Operating Status .....31  
 Viewing and changing temperature .....32  
 Viewing and changing system setting .....33  
 Initial start and operating instruction .....35  
 Sequence of Operation.....36  
 Combustion check and fuel input rate .....37  
 Safety Check .....37  
 Diagnostic error codes .....38  
 Care and Maintenance .....41  
 General Troubleshooting Guide .....42

### IMPORTANT

**READ ALL OF THE FOLLOWING WARNINGS AND STATEMENTS BEFORE READING THE INSTALLATION INSTRUCTIONS**

**WARNING**  
SEE "WARNING" ON PAGE 4 FOR LIQUEFIED PETROLEUM (L.P.) PROPANE GAS-FIRED BOILERS

The installation must conform to the requirements of the authority having jurisdiction or, in the absence of such requirements, to the National Fuel Gas Code, ANSI Z223.1-latest edition. The installation must also conform to the additional requirements in this Slant/Fin Instruction Book.

In addition where required by the authority having jurisdiction, the installation must conform to American Society of Mechanical Engineers Safety Code for Controls and Safety Devices for Automatically Fired Boilers, No. CSD-1.

**WARNING**  
This boiler, gas piping and accessories must be installed, connected, serviced and repaired by a trained, experienced service technician, familiar with all precautions required for gas-fired equipment and licensed or otherwise qualified, in compliance with the authority having jurisdiction.

**WARNING**  
The venting system of this boiler is under positive pressure. Leakage from this system can be hazardous and if not avoided can result in death or serious injury. In addition to the recommendations within this manual and the User's Information Manual, the venting system, from the flue collector to the outdoor discharge, must be carefully checked annually by a qualified service agency.

**Heating Contractor**  
\_\_\_\_\_

**Address**  
\_\_\_\_\_  
\_\_\_\_\_

**Phone Number**  
\_\_\_\_\_

**Boiler Model Number**  
\_\_\_\_\_

**Boiler Serial Number**  
\_\_\_\_\_

**Installation Date**  
\_\_\_\_\_

## **RATINGS AND DIMENSIONS**

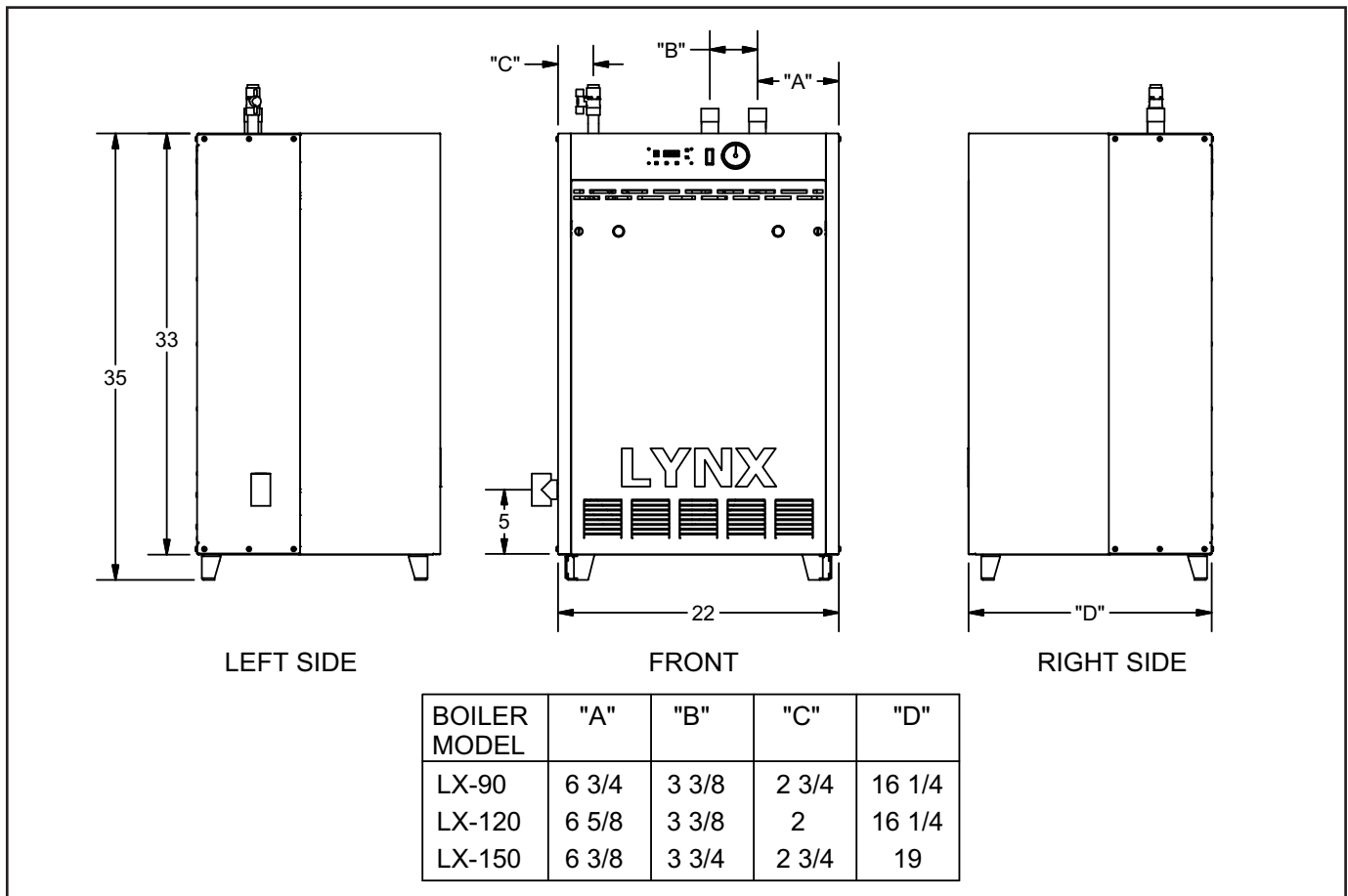

Figure 1. Dimensions data

| SPECIFICATIONS                   |      | BOILER MODEL  |                     |                     |
|----------------------------------|------|---|---------------------|---------------------|
|                                  |      | LX-90   | LX-120              | LX-150              |
| Input Rate, Btu/Hr               | Max. | 90,000  | 120,000             | 150,000             |
|                                  | Min. | 25,000  | 30,000              | 37,500              |
| Water Piping Connection          |      | 1" NPT (Male)   |                     |                     |
| Gas Piping Connection            |      | 1/2" NPT (Female)   |                     |                     |
| Vent Connection                  |      | 3" Nominal ID Pipe PVC, CPVC, Polypropylene (solid or flexible) or SS. <b>SEE WARNING</b> |                     |                     |
| Air Intake Connection            |      | 3" Nominal ID PVC or CPVC   |                     |                     |
| Gas Orifice Size for Natural Gas |      | No Orifice Used   |                     |                     |
| Gas Orifice Size for Propane     |      | 0.1900"<br>Code # C   | 0.2025"<br>Code # A | 0.2200"<br>Code # E |
| Boiler Water Volume              | Gal. | 0.4   | 0.6                 | 1.1                 |
| Weight of Boiler (Uncrated)      | Lbs. | 118   | 125                 | 140                 |

### **WARNING:**

1. Use of cellular core PVC and CPVC or Radel for venting system is NOT allowed
2. Thermal insulation on non-metallic vent pipe and fittings is NOT allowed.

**LOCATION AND IDENTIFICATION OF PARTS**

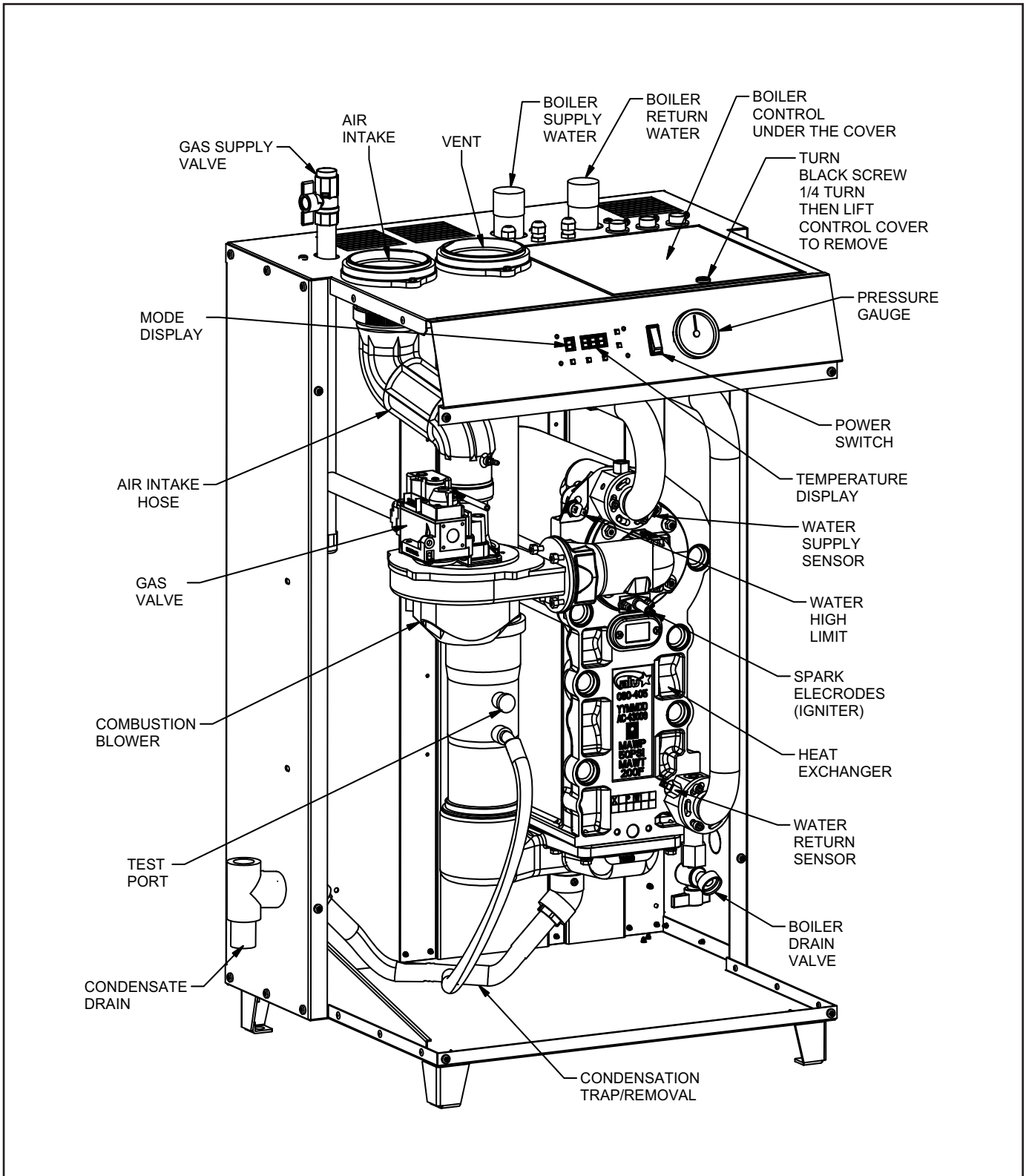

Figure 2. Location and identification of parts (front and side panels are removed) model LX-150 is shown

## INSTALLATION REQUIREMENTS

The installation must conform to the requirements of the authority having jurisdiction or, in the absence of such requirements, to the National Fuel Gas Code, ANSI Z223.1-latest edition.

This installation must also conform to the additional requirements in this Slant/Fin Instruction Book.

### BOILER LOCATION

Provide a level, solid foundation or vertical wall for the boiler. Location should be as near as possible to chimney or outside wall so that the flue pipe from boiler is short and direct. (See paragraph heading "Vent Termination Location and Clearance" on page 9.) The location should also be such that all boiler components are protected from water (dripping, spraying, rain, etc.) during appliance operation and service (circulator replacement, control replacement, etc.).

### WARNING

#### SPECIAL ATTENTION FOR LIQUEFIED PETROLEUM (L.P.) PROPANE GAS-FIRED BOILER INSTALLATIONS

LPG appliances (boilers) shall be installed in accordance with applicable provisions of NFPA 58 (Liquefied Petroleum Gas Code) latest for installations in US and CAN/CGA B149.1 latest edition for installations in Canada.

Liquefied Petroleum (LP) propane gas is heavier than air therefore Propane gas accumulate at floor level. If you suspect a leak, do not attempt to operate boiler. A spark or flame from the appliance (boiler) or other sources may ignite the accumulated propane gas causing an explosion or fire. It is recommended that inspections for gas leaks be performed periodically by licensed professional and that leak detection devices be installed as a further safety measure.

### BOILER FOUNDATION

- Provide a solid, level foundation or vertical wall capable of supporting the weight of the boiler filled with water, and extending at least 2" past the jacket on all sides. See dimensions of boilers, page 2. See also figure 4a & 4b for mounting the boiler on the wall.
- Boiler can be installed on both combustible and non-combustible floors, but must NOT be installed on or above carpeting.
- If boiler is to be located over buried conduit containing electric wires or telephone cables, consult local codes or the National Board of Fire Underwriters for specific requirements.

## MINIMUM CLEARANCES FROM COMBUSTIBLE CONSTRUCTIONS

- Minimum clearances to the exterior surfaces of the boiler shall be as follows:

### MINIMUM ALCOVE AND CLOSET CLEARANCE

| Surface         | For Combustible Construction | Recommended for Service |
|-----------------|------------------------------|-------------------------|
| Front           | 6"                           | 18"                     |
| Rear            | 0"                           | 0"                      |
| Left Side       | 0"                           | 8"                      |
| Right Side      | 0"                           | 8"                      |
| Top             | 5"                           | 18"                     |
| Flue Connector: |                              |                         |
| Enclosed —      | 2"                           | 6"                      |
| Uninclosed —    | 1"                           | 6"                      |

- Provide accessibility clearance of 8" on sides requiring servicing and 18" on sides used for passage.
- All minimum clearances shown above must be met. This may result in increased values of some minimum clearances in order to maintain the minimum clearances of others.
- Clearance from hot water pipes shall be 1 inch\*\*.

\*\* At points where hot water pipes emerge from a floor, wall or ceiling, the clearance at the opening through the finished floor boards or wall or ceiling boards may be not less than 1/2 inch. Each such opening shall be covered with a plate of uncombustible material.

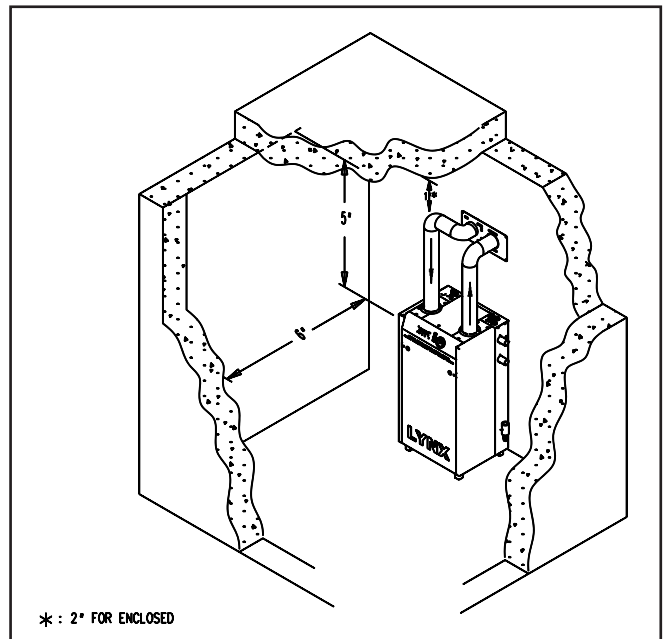

Figure 3. Lynx boiler min. clearances for combustible construction.

### SAFETY

KEEP THE BOILER AREA CLEAR AND FREE FROM COMBUSTIBLE MATERIALS, GASOLINE AND OTHER FLAMMABLE VAPORS AND LIQUIDS.

## CONTAMINATION PREVENTION

The combustion air supply must not be susceptible to contamination sources, whether the combustion air comes from the interior or exterior of the building. Contaminated air can cause corrosion or other damage to the heat exchanger and components of the boiler, causing failure of these parts or unsafe operation.

Below is a list of products and areas which may cause contaminated combustion air:

### PRODUCTS TO AVOID

- Spray cans containing chloro/fluorocarbons
- Permanent wave solutions
- Chlorinated waxes/cleaners
- Chlorine-based swimming pool chemicals
- Calcium chloride used for thawing
- Sodium chloride used for water softening
- Refrigerant leaks
- Paint or varnish removers
- Hydrochloric acid/muriatic acid
- Cements and glues
- Antistatic fabric softeners used in clothes dryers
- Chlorine-type bleaches, detergents, and cleaning solvents found in household laundry rooms
- Adhesives used to fasten building products and other similar products

### AREAS LIKELY TO HAVE CONTAMINANTS

- Dry cleaning/laundry areas and establishments
- Swimming pools
- Metal fabrication plants
- Beauty shops
- Refrigeration repair shops
- Photo processing plants
- Auto body shops
- Plastic manufacturing plants
- Furniture refinishing areas and establishments
- New building construction
- Remodeling areas
- Garages with workshops

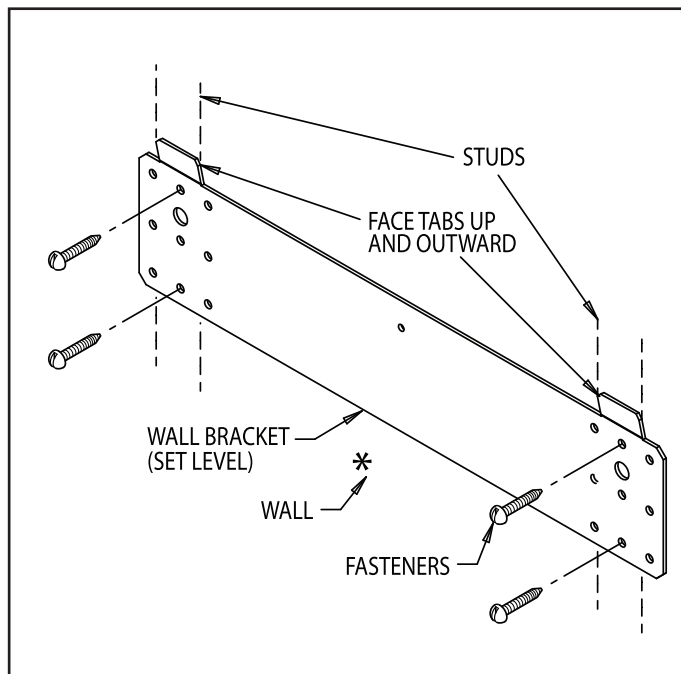

Figure 4a. Wall bracket securement

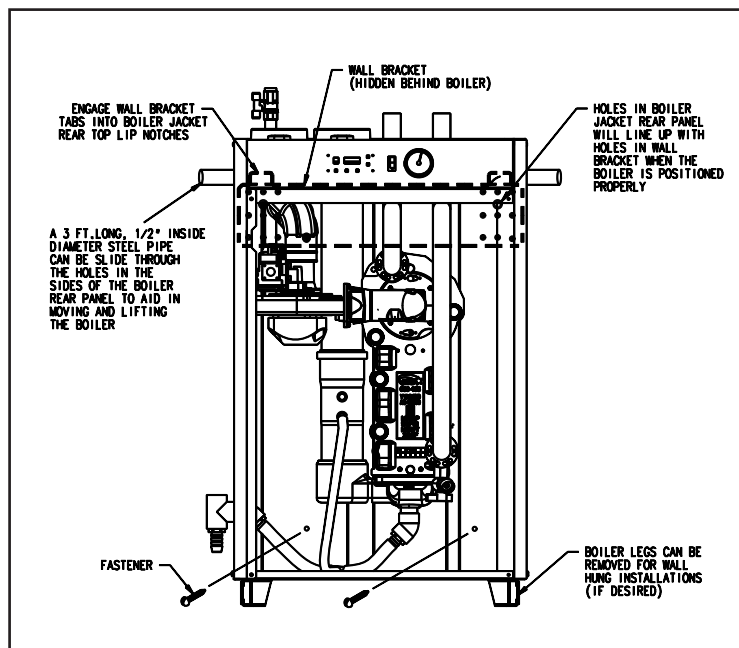

Figure 4b. Mounting boiler on the wall

### **MOUNTING THE BOILER ON A WALL**

Be sure that the wall is vertically plumb and capable of carrying the weight of the boiler and the system piping, when full of water. See page 2 for the boiler weight.

Be sure that there are studs available in the proper locations, for securing the boiler wall bracket and back panel. (See Figures 4a and 4b).

For wood stud walls, use lag screws or wood screws with a coarse thread and a minimum of 3" in length.

For metal stud walls, use toggle-style bolts that are specifically designed for such and maximum capacity exceeds the weight of the boiler and the system piping when full of water.

DO NOT use anchors driven into sheetrock to hold the boiler up on the wall. If mounting the boiler on a cement wall, use anchors that are specifically designed for such, and maximum capacity exceeds the weight of the boiler and the system piping, when full of water.

#### **A. INSTALL THE WALL BRACKET. SEE FIGURE 4a.**

1. Remove the wall bracket from the boiler jacket rear panel, by unfastening the single screw that holds it in place, for shipping purposes only.
2. Select the location on the wall where the boiler will be mounted. The upward facing tabs of the wall bracket will align with the top surface of the boiler jacket, and 3 feet of open wall space will be needed to accommodate the boiler jacket rear panel below this.
3. For sheetrock and stud construction, locate the studs and determine which set of holes in the wall bracket best align with the center of the studs. For cement walls, determine a location for the wall bracket to mount where the anchors will be secure, devoid of seams or cracks.
4. Place the bracket in the selected location, with the 2 tabs positioned up and facing outward, level it out, and mark the holes to be used. A minimum of 4 of these holes must be utilized, regardless of wall material.
5. Drill the appropriate diameter and depth holes for the fasteners used in the wall, where marked.
6. Fasten the wall bracket to the wall, being sure that the tabs face upward and outward, and the fasteners have engaged the wall properly.

#### **B. INSTALL THE BOILER ON THE WALL. SEE FIGURE 4b.**

1. Remove the boiler jacket front cover, by turning the 2 black screws 1/4 turn to the open position, then lifting off.
2. Remove both the boiler jacket side panels, by removing the 2 sheetmetal screws in the top and bottom front edge, then lift off.
3. To aid in lifting the boiler, a 3 foot long, 1/2" inside diameter steel pipe can be slid through the holes in the sides of the boiler rear panel. Let the pipe extend out each side of the jacket evenly, for hand-holds, and pick up the boiler without letting it tilt, for safety.

4. Lift the boiler up against the wall, with the top edge of the jacket slightly above the wall bracket tabs. There are 2 holes in the upper corners of the jacket rear panel, that can visually be aligned with the 2 larger diameter holes in the wall bracket, to ensure that the wall bracket tabs line up and engage with the boiler jacket near top lip notches properly.
5. There are 2 fastener holes in the lower area of the boiler rear panel, just below the flue collector, for insuring the boiler does not move off the wall bracket. Mark these 2 holes, with the boiler in place, then lift the boiler off the wall bracket.
6. Determine which fastener type will best engage with the wall construction at the location of the 2 marked holes. Drill out the appropriate diameter and depth holes for the fasteners, where marked.
7. Lift the boiler up onto the wall bracket again, as described in Step 4. Secure the boiler to the wall, with the 2 fasteners in the lower rear panel area.
8. If able to, the 1/2" diameter lifting pipe should be removed from the boiler rear panel.
9. The 4 boiler legs may be removed at this time, if desired. 2 screws hold each leg in place, from inside the jacket panel.
10. The boiler side panels can be replaced at this time, but the front panel should be left off, for the startup procedure later in the installation.

### **VENTING APPLICATION**

Lynx boilers are sealed combustion type boilers, it may be installed and vented either as a direct vent boiler which all air for combustion is obtained directly from outside or as a non-direct vent boiler which air for combustion is taken from inside the boiler room.

Lynx boilers must be vented by 3" diameter PVC/CPVC schedule 40 pipe, 3" nominal ID polypropylene pipe or the proper 3" diameter stainless steel venting system (see "vent material" on page 8) through the roof or sidewall.

### **BOILER ROOM AIR SUPPLY AND VENTILATION**

An ample supply of air is required for combustion and ventilation. When buildings are insulated, caulked and weatherstripped, now or later on, direct openings to outside may be required and should be provided. If the boiler is not near an outside wall, air may be ducted to it from outside wall openings.

Provisions for combustion and ventilation air must be made in accordance with section 5.3, Air for Combustion and Ventilation, of the National Fuel Gas Code, ANSI Z223.1-latest edition, or applicable provisions of the local building codes. The following recommendation applies to buildings of energy-saving construction, fully caulked and weatherstripped.

**INSTALLATION IN ENCLOSED BOILER ROOM REQUIRES TWO UNOBSTRUCTED OPENINGS FOR PASSAGE OF AIR INTO THE BOILER ROOM:**

**A. NON-DIRECT VENT INSTALLATION**

1. **Air drawn horizontally from outdoors DIRECTLY through an outside wall;** one louvered opening near the floor and one louvered opening near the ceiling, each opening with a minimum FREE air passage area of **1 square inch per 4000 Btuh** of total appliances' input.
2. **Air drawn horizontally through HORIZONTAL DUCTS;** one opening near the floor and one opening near the ceiling, each opening with a minimum FREE air passage area of **1 square inch per 2000 Btuh** of total appliances' input.
3. **Air drawn VERTICALLY from outdoors;** one opening at the floor and one opening at the ceiling, each opening with a minimum FREE air passage area of **1 square inch per 4000 Btuh** of total appliances' input.
4. **Air drawn from inside the building;** one opening near the floor and one opening near the ceiling, each opening with a minimum FREE air passage area of **1 square inch per 1000 Btuh** of total appliances' input.

IF BOILERS ARE INSTALLED ADJACENT TO OTHER FUEL BURNING EQUIPMENT, THE AREA OF FREE OPENINGS MUST BE APPROPRIATELY INCREASED TO ACCOMMODATE THE ADDITIONAL LOAD.

**B. DIRECT VENT INSTALLATION**

Adequate air supply should be provided to prevent overheating of the boiler controls and boiler room. Openings for passage of air into the boiler room for direct-vent installation must be at least  $\frac{1}{2}$  of the openings required for the non-direct vent as mentioned above.

If additional non-direct vent appliances are installed in the same space and adequate air openings are provided for them, there are no additional air openings required for the Lynx boiler.

For both direct and non-direct installation, the following must be considered:

- Openings must never be reduced or closed. If doors or windows are used for air supply, they must be locked open.
- Protect against closure of openings by snow and debris. Inspect frequently.
- No mechanical draft exhaust or supply fans are to be used in or near the boiler area.
- Boiler area must never be under negative pressure. The flow of combustion and ventilating air to the boiler must not be obstructed.

**FLUE GAS VENTING REQUIREMENTS**

The Lynx boiler is a high efficiency, mechanically forced draft boiler and, therefore, require different venting arrangements than natural draft, lower efficiency boilers.

THE FOLLOWING INSTRUCTIONS MUST BE CAREFULLY READ AND FOLLOWED IN ORDER TO AVOID ANY HAZARDOUS CONDITIONS DUE TO IMPROPER INSTALLATION OF THE AIR INTAKE AND FLUE GAS VENTING SYSTEM.

The vent piping installation MUST be in accordance with these instructions and with ANSI Z223.1-latest edition NATIONAL FUEL GAS CODE, Part 7, Venting of Equipment. Other local codes may also apply and must be followed. Where there is a conflict between these requirements, the more stringent case shall apply. The use of a vent damper is NOT permitted on this boiler series.

**ADDITIONAL REQUIREMENTS FOR THE COMMONWEALTH OF MASSACHUSETTS**

When the Bobcat is installed and used in the Commonwealth of Massachusetts, the following additional requirements pursuant to Massachusetts code 248 CMR MUST be met:

(1). Existing chimneys shall be permitted to have their use continued when a gas conversion burner is installed, and shall be equipped with a manual reset device that will automatically shut off gas to the burner in the event of a sustained back-draft.

(2)(a). For all side wall horizontally vented gas fueled equipment installed in every dwelling, building or structure used in whole or part for residential purposes, including those owned or operated by the Commonwealth and where the side wall exhaust vent termination is less than seven (7) feet above finished grade in the area of the venting, including but not limited to decks and porches, the following requirements shall be satisfied:

1. **INSTALLATION OF CARBON MONOXIDE DETECTORS.** At the time of installation of the side wall horizontal vented fueled equipment, the installing plumber or gasfitter shall observe that a hard wired carbon monoxide detector with an alarm and battery back-up is installed on the floor level where the gas equipment is to be installed. In addition, the installing plumber or gasfitter shall observe that a battery operated or hard wired carbon monoxide detector with an alarm is installed on each additional level of the dwelling, building or structure served by the side wall horizontal vented gas fueled equipment. It shall be the responsibility of the property owner to secure the services of qualified licensed professionals for the installation of hard wired carbon monoxide detectors.

a. In the event that the side wall horizontally vented gas fueled equipment is installed in a crawl space or an attic, the hard wired carbon monoxide detector with alarm and battery back up may be installed on the next adjacent floor level.

b. In the event that the requirements of this subdivision can not be met at the time of completion of installation, the owner shall have a period of thirty (30) days to comply with the above requirements; provided, however, that during said thirty (30) day period, a battery operated carbon monoxide detector with an alarm shall be installed.

2. **APPROVED CARBON MONOXIDE DETECTORS.** Each carbon monoxide detector as required in accordance with the above provisions shall comply with NFPA 720 and be ANSI/UL 2034 listed and IAS certified.

3. **SIGNAGE.** A metal or plastic identification plate shall be permanently mounted to the exterior of the building at a minimum height of eight (8) feet above grade directly in line with the exhaust vent terminal for the horizontally vented gas fueled heating appliance or equipment. The sign shall read, in print size no less than one-half (1/2) inch in size, "**GAS VENT DIRECTLY BELOW, KEEP CLEAR OF ALL OBSTRUCTIONS**".

4. **INSPECTION.** The state or local gas inspector of the side wall horizontally vented gas fueled equipment shall not approve the installation unless, upon inspection, the inspector observes carbon monoxide detectors and signage installed in accordance with the provisions of 248 CMR 5.08(2)(a)1 through 4.

(b) **EXEMPTIONS.** The following equipment is exempt from 248 CMR 5.08(2)(a)1 through 4:

1. The equipment listed in Chapter 10 entitled "Equipment Not Required TO Be Vented" in the most current edition of NFPA 54 as adopted by the Board; and
2. Product Approved side wall horizontally vented gas fueled equipment installed in a room or structure separate from the dwelling, building or structure used in whole or part for residential purposes.

## VENT AND AIR INTAKE MATERIALS

The vent and air intake system for direct or non-direct vent installation must be 3" diameter PVC/CPVC schedule 40 pipe, 3" nominal polypropylene (solid or flexible) or UL listed single wall 3" diameter AL29-4C\* stainless steel material. The following manufacturers' systems are approved for use within a specified minimum and maximum equivalent vent length in this manual.

| Manufacturer               | Type/System            | Sealant                |
|----------------------------|------------------------|------------------------|
| Heat-Fab. Inc.             | Saf-T Vent EZ Seal     | Not Required           |
| ProTech System, Inc.       | FasNSeal               | Not Required           |
| Flex-L International, Inc. | StaR-34                | GE-IS806               |
| N/A                        | PVC pipe, Schedule 40  | PVC primer and cement  |
| N/A                        | CPVC pipe, Schedule 40 | CPVC primer and cement |
| Centrotherm Eco System     | Polypropylene          | Not required           |

\*AL29-4C is a registered Trademark of Allegheny Ludlum Corp

**WARNING:** 1. Use of cellular core PVC and CPVC or Radel for venting system is NOT allowed 2. Thermal insulation on non-metallic vent pipe and fittings is NOT allowed.

When joining the various components of the listed stainless steel vent systems, the manufacturers' instructions should be closely followed to insure proper sealing. Use sealant specified by vent system manufacturer for sealing of pipe and fittings, if required. When joining the PVC/CPVC pipe and fittings, follow the instructions provided in this manual. All connections must be liquid and pressure tight. DO NOT use galvanized flue pipe or any plastic-type materials other than specified above.

The integral flue adapter on the boiler is designed to accommodate either PVC/CPVC Schedule 40 pipe, polypropylene or the listed stainless steel vent systems. This adapter has built-in sealing rings, so no additional sealant is required. Make sure the pipes are round and burr-free, and push down into the appropriate step of the adapter, until snug. (See Figure 5). Apply liquid soap to the outer end of the vent pipe and air intake pipe for easy insertion.

The integral air intake adapter on the boiler is designed to take PVC/CPVC pipe.

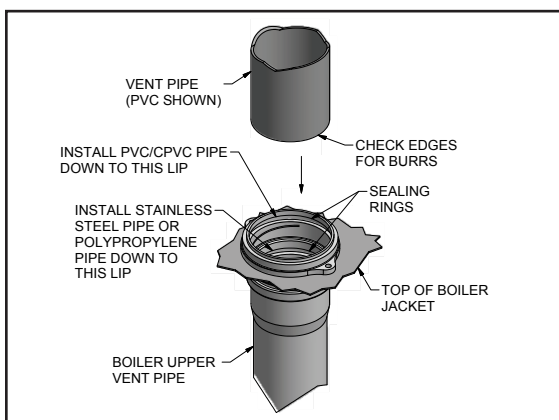

Figure 5. Vent Pipe installation into Boiler Adapter.

## PVC/CPVC PIPE GENERAL ASSEMBLY METHOD

The following are the recommended methods for cutting, cleaning and connecting PVC and CPVC pipe, for both the vent and air intake piping system:

1. When laying out the piping system, work from the boiler vent and air intake adapter to the point of outside termination.
2. Cut the PVC/CPVC pipe to the required lengths, and pre-assemble the entire system, before sealing. Disassembly after sealing, to make any corrections, will not be possible.
3. Once the pre-assembled PVC/CPVC pipe vent and air intake system is verified to be of the proper length pipe and fitting orientation, begin disassembling and preparing the pipes and fittings for the sealing process. This can be done section by section, or the complete vent and air intake system can be disassembled. It is recommended to mark the various parts, before complete disassembly, to eliminate the possibility of errors during re-assembly.
4. De-burr the inside and outside of every PVC/CPVC pipe, to ensure that they engage fully into the fittings, and flow is not compromised. A small chamfer on the outside of each pipe can particularly aid in the final assembly process.
5. Wipe or knock out any debris from inside the PVC or CPVC pipe, which may have accumulated there from the cutting process or storage. Debris can cause operational problems with the boiler combustion components.
6. Thoroughly clean the outside ends of each pipe, and the inside of each fitting. The surfaces must be dry for the sealing agents to work properly. Handle the prepared pipe lengths away from the cleaned ends, and handle the cleaned fittings, from the outside, to avoid contamination.
7. Re-assembly of the PVC or CPVC pipe should be done in sections, to avoid the primer and cement drying before the parts are engaged.
8. For each joint, first apply a coat of primer to the outside sealing surface of the pipe and the inside sealing surface of each fitting. Use only the primer type that is specified for either the PVC or CPVC pipe that is being utilized.
9. Before the primer dries, apply a coat of cement over it. A second coat of cement can be applied, if necessary, but must be done quickly and in a manner that avoids unnecessary build-up that would cause obstruction inside the system. Use only the cement type that is specified for either the PVC or CPVC pipe that is being utilized.
10. Before the cement dries, insert the pipe into the fitting. A slight twisting motion while pushing the pipe into the fitting will aid in distributing the cement evenly and ensuring the parts fully engage.
11. Quickly wipe the excess cement from the outside areas of the joint. Discard any rags used to avoid later getting the cement on hands, clothes and equipment.

**Note: Polypropylene pipe, follow manufacturers instructions.**

## VENT AND AIR INTAKE RESTRICTIONS

1. Maximum allowed equivalent vent and air intake length for all of the approved vent and air intake materials is 100 feet.
2. Equivalent of vent or air intake length is sum of the straight pipe lengths and equivalent length of elbows as shown in the table on page 9.



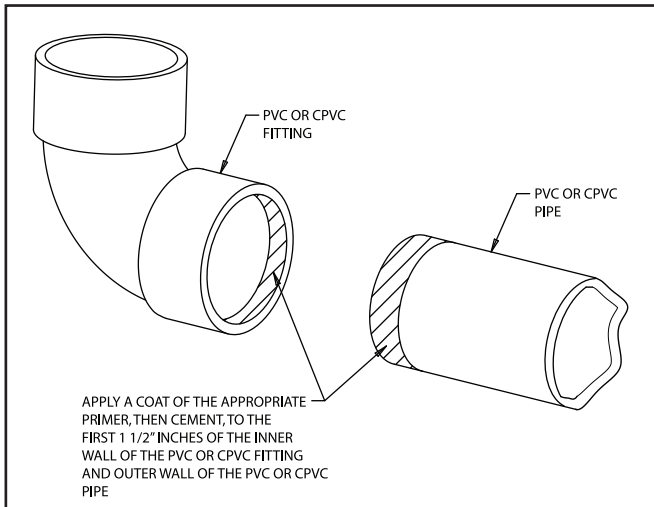

Figure 6.

3. The vent termination is in addition to the allowed equivalent lengths.
4. Minimum vent length is 2 feet of straight pipe, plus one 90° elbow that is required.
5. Vent length restriction is for both direct and non-direct vent installations.

**EXAMPLE:** The combustion air is provided by air intake piping directly to the boiler (direct-vent installation). The vent piping will be PVC and installation will require the use of 4 elbows for the vent to run the termination. The air intake piping will also be PVC, and also will require the use of 4 elbows.

In this case, the maximum straight pipe vent length that can be utilized with the 4 elbows would be:  $100' - (4 \times 5') = 80'$ . Since the air intake pipe also is PVC and requires the use of 4 elbows, the maximum straight pipe air intake length that can be utilized is also 80 feet.

If the air for combustion were taken from the boiler room (non-direct vent installation), still the maximum straight vent length would be 80 feet.

6. The Lynx boiler is equipped with a built-in condensation drain and trap. The trap must be filled with water. DO NOT operate the boiler without filling the trap with water to prevent flue gas discharge into space. The drain must dispose of possibly large quantities of condensate, which may require a neutralizing system. Refer to the “Condensate Drainage” section of this manual. No additional condensation drain and trap is required on the vent piping system itself.
7. The horizontal vent pipe must be sloped upward from the boiler at a pitch of at least 1/4” per 1 foot of run, so that the condensate from the vent system runs to the boiler vent adapter pipe, then out the built-in condensation drain and trap.
8. The horizontal vent and air intake pipes must be supported with pipe straps, at intervals no greater than 5 feet, when polypropylene, PVC/CPVC pipe is utilized. This support spacing applies also to stainless steel vent pipe, unless the manufacturer’s instructions permit otherwise. The vertical vent and air intake pipes also must be supported, wherever the building construction provides allowance for it, such as ceiling or roof passage openings where a firestop and support or braces can be affixed.
9. Minimum clearances of vent pipes from combustible constructions must be maintained (see Page 4). No clearance is required between the vent and air intake pipes of this boiler.
10. Common venting with other appliances or another Lynx boiler is not allowed.
11. DO NOT install a vent damper or similar devices in vent system or on the boiler.
12. DO NOT insulate venting system.

**Equivalent Length of Various 90-Degree Elbows**

| Manufacturer               | Type/System               | Equivalent length (Ft.) |
|----------------------------|---------------------------|-------------------------|
| Heat-Fab, Inc.             | Saf-T Standard elbow      | 3                       |
| Heat-Fab, Inc.             | Saf-T, tight radius elbow | 6                       |
| ProTech System, Inc.       | FasNseal                  | 6                       |
| Flex-L International, Inc. | StaR-34                   | 6                       |
| N/A                        | PVC, Schedule 40          | 5                       |
| N/A                        | CPVC, Schedule 40         | 5                       |
| Centrotherm Eco Systems    | Polypropylene             | 5                       |

## VENTING INSTALLATION

Only the PVC/CPVC, polypropylene and approved stainless steel materials listed on page 8 may be used for the venting system installation. If stainless steel vent systems are used, follow the manufacturer's instructions, in conjunction with these instructions.

### I. Non-Direct Vent Installation

The air for combustion is taken from the ambient air surrounding the boiler; therefore, ample supply of air is required for combustion and ventilation (see page 7.)

DO NOT use this installation method if the surrounding of the boiler is contaminated. See page 5 for the list of harmful contaminants and their sources, to avoid.

### A. SIDEWALL VENTING - NON-DIRECT VENT

Figures 7 and 8 show typical horizontal sidewall venting. For combustible wall passage of vent piping, a UL listed thimble or flashing and sealing boot must be used, providing the wall thickness from 3" minimum up to 12" maximum. The vent piping must terminate with a screened tee or elbow termination facing down.

**CAUTION:** Flue gasses exiting from the vent terminal will condense. Building materials in the area of the vent terminal should be protected from discoloration and degradation.

### VENT TERMINATION LOCATION AND CLEARANCES

1. The venting system shall terminate at least 3 feet above any forced air inlet located within 10 feet.
2. The venting system shall terminate at least 12 inches below, or 12 inches horizontally from, any door, window or gravity air inlet into any building. The bottom of the vent terminal or air intake terminal shall be at least 12 inches above grade or the normal snow level whichever is greater.
3. Through the wall vents shall not terminate over public walkways or over areas where condensate or vapor could create a nuisance or hazard or could be detrimental to the operation of regulators, relief valves or other equipment. Minimum clearance of 4 feet horizontal distance is maintained, from electric meters, gas meters, regulators and relief equipment.
4. Vent termination must not be located in any confined space (i.e. window wells, alcoves, narrow alleys) or under any overhang or deck. Vent termination should not allow flue gas discharge towards neighbor's windows or where personal injury or property damages can occur.

### B. NON-DIRECT VENT - VERTICAL VENTING

Figure 9 shows typical venting through the roof. The vent pipe must pass through the ceiling, floor and the roof vertically through a 6" minimum diameter cutout. A fire stop is required for each ceiling and floor penetration. For roof passage, an appropriate UL listed roof flashing must be used.

An existing chimney (see Figure 10) may be used as a chase for vertical venting. Other appliances CANNOT be vented into the same chimney or vent pipe within the chimney.

The vertical vent piping must terminate with a screened tee, combination of 45° elbow and a 90° screened elbow termination or a rain cap termination.

### II. Direct Vent Installation

Air intake piping from outside to the boiler air intake adapter provides the air for combustion. The boiler surrounding may be contaminated (See page 5). Piping the air intake to the outside can prevent contaminants from the boiler surrounding from entering the combustion air supply.

### A. SIDEWALL DIRECT VENTING

Figures 11 and 12 show typical sidewall direct venting, using a Slant/Fin vent/air intake termination. There are 2 different models of vent/air intake termination available. One is designed specifically for PVC/CPVC or polypropylene venting, and the other is designed specifically for stainless steel venting systems. Only these 2 models of vent/air intake termination are approved for this method of installation. Refer to the Slant/Fin boilers Parts List (publication number LXA-10PL) for the appropriate model for the vent material to be used.

**CAUTION:** Flue gasses existing from the vent terminal will condense. Building materials in the area of the terminal should be protected from discoloration and degradation.

Vent termination location and clearances for non-direct vent stated on Paragraph I, also applies to sidewall direct venting.

### Alternate Sidewall venting for direct or non-direct venting:

Vent and/or air intake piping may be installed per figure 12a in order to provide enough clearance from snow line. The total vent/air intake equivalent length must not exceed 100 ft.

In cold climates, install an insulated enclosure around the vent piping to protect from freezing.

**NON-DIRECT VENT, SIDEWALL VENTING**

All joints must be liquid and pressure tight. Use 3" dia. PVC/CPVC schedule 40 pipe, 3" nominal ID polypropylene pipe or U/L listed single wall 3" dia. AL29-4C S.S.\*. venting materials (See page 7).

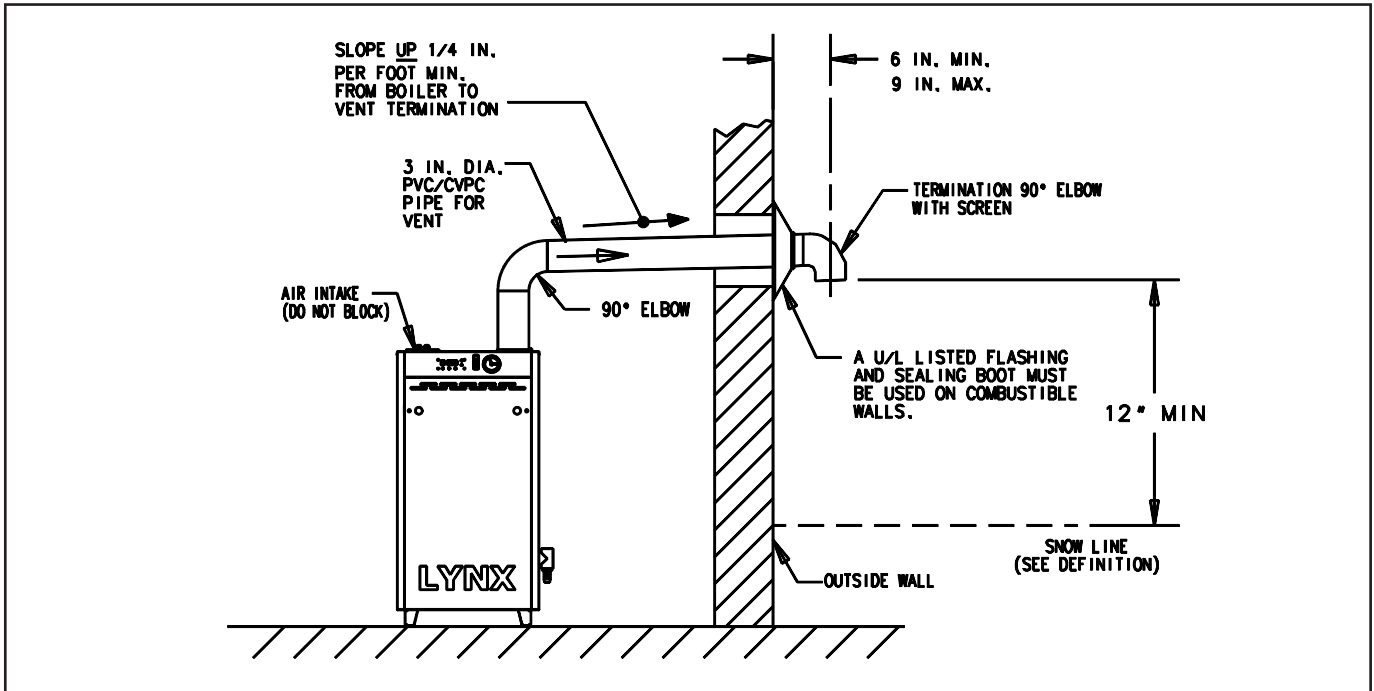

Figure 7. Non-direct vent, side wall venting - utilizing PVC/CPVC or polypropylene pipe for venting.

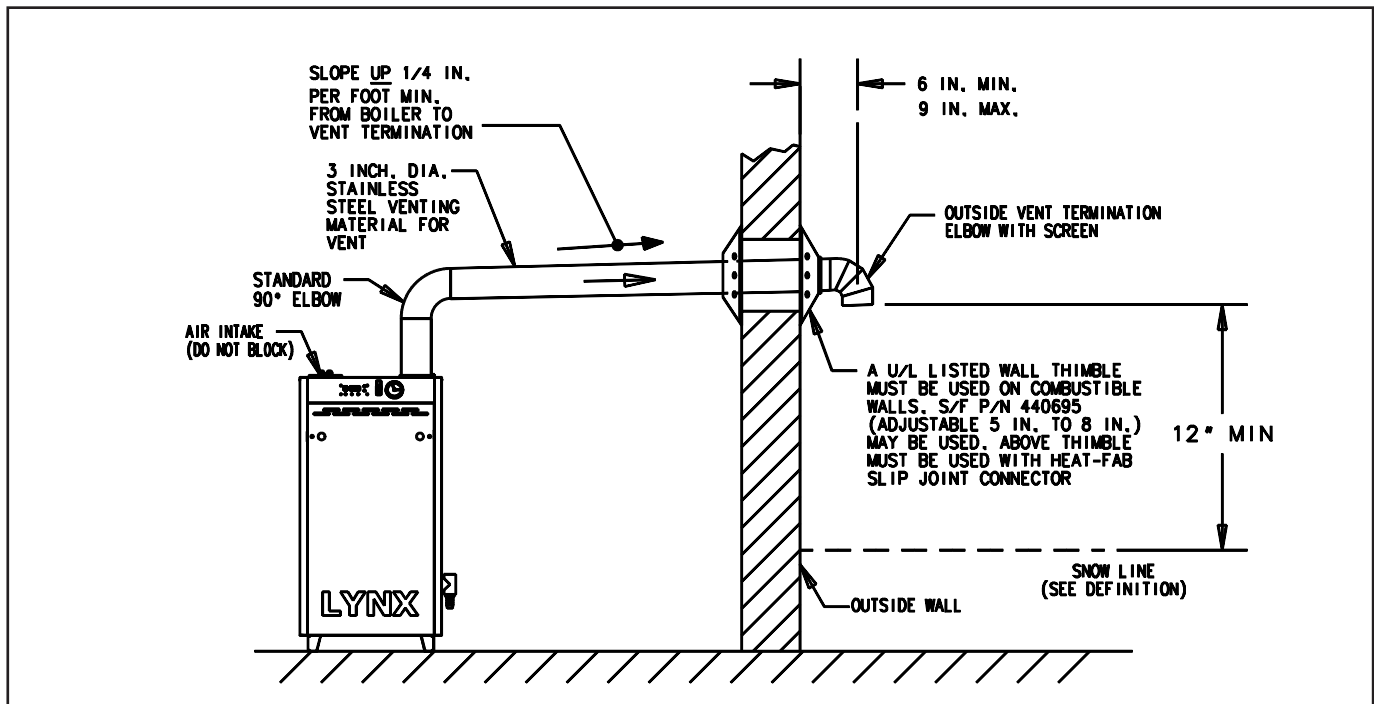

Figure 8. Non-direct vent, side wall venting - utilizing stainless steel vent materials for venting.

\*\* Definition of Snow Line: Knowledge of local conditions will reveal the maximum height that repeated snowfalls accumulate to. The height should be used as the SNOW LINE.

\* AL 29-4C IS A REGISTERED TRADEMARK OF ALLEGHENY LUDLUM CORP.

**NON-DIRECT VENT, VENTING THROUGH A ROOF**

All joints must be liquid and pressure tight. Use 3" dia. PVC/CPVC schedule 40 pipe, 3" nominal polypropylene pipe or U/L listed single wall 3" dia. AL29-4C S.S.\*. venting materials (See page 7).

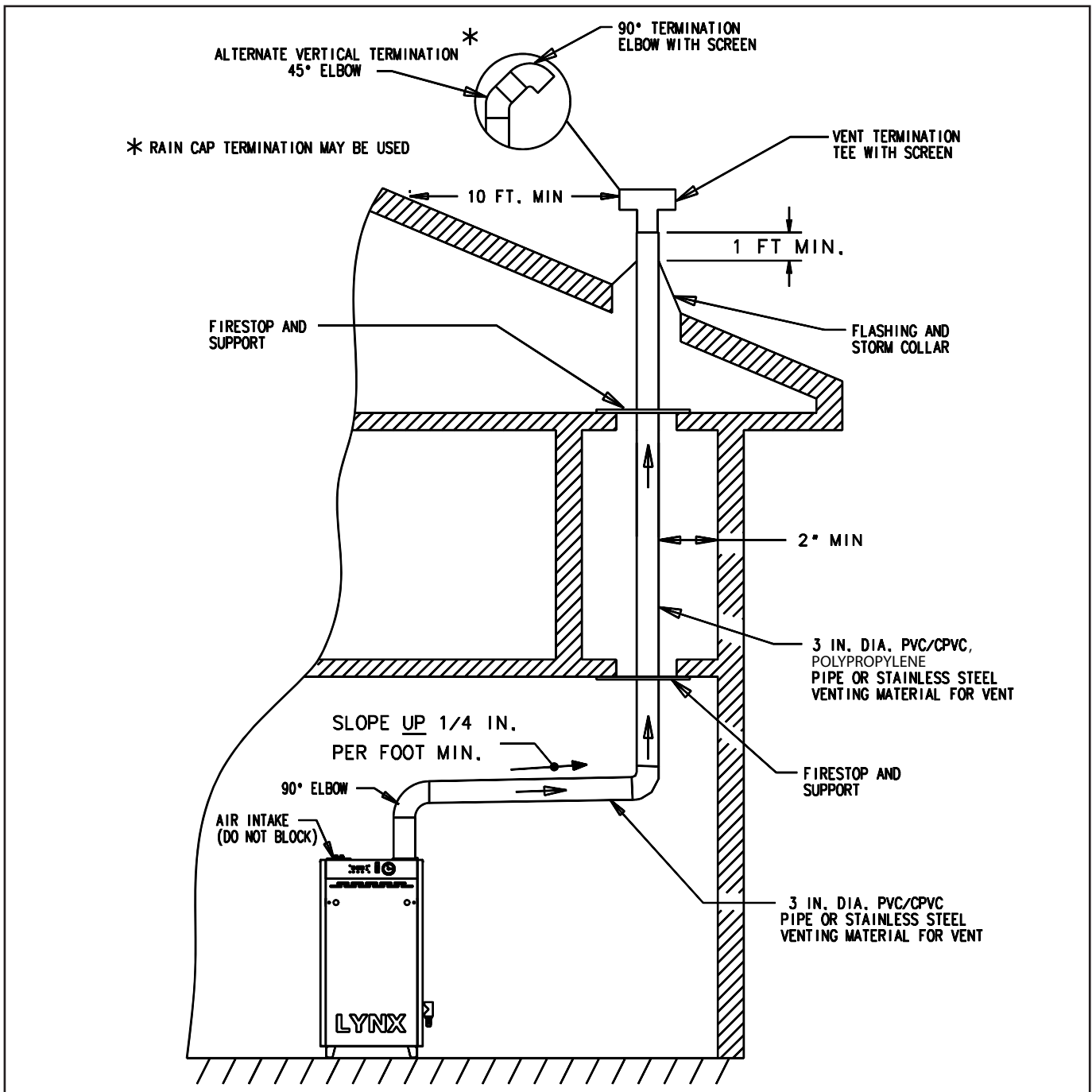

Figure 9. Lynx - non-direct vent, venting through the roof

\* AL 29-4C IS A REGISTERED TRADEMARK OF ALLEGHENY LUDLUM CORP.

**NON - DIRECT VENT, UTILIZING AN EXISTING CHIMNEY AS A CHASE**

All joints must be liquid and pressure tight. Use 3" dia. PVC/CPVC schedule 40 pipe, 3" ID polypropylene or U/L listed single wall 3" dia. AL29-4C S.S.\*. venting materials (See page 7).

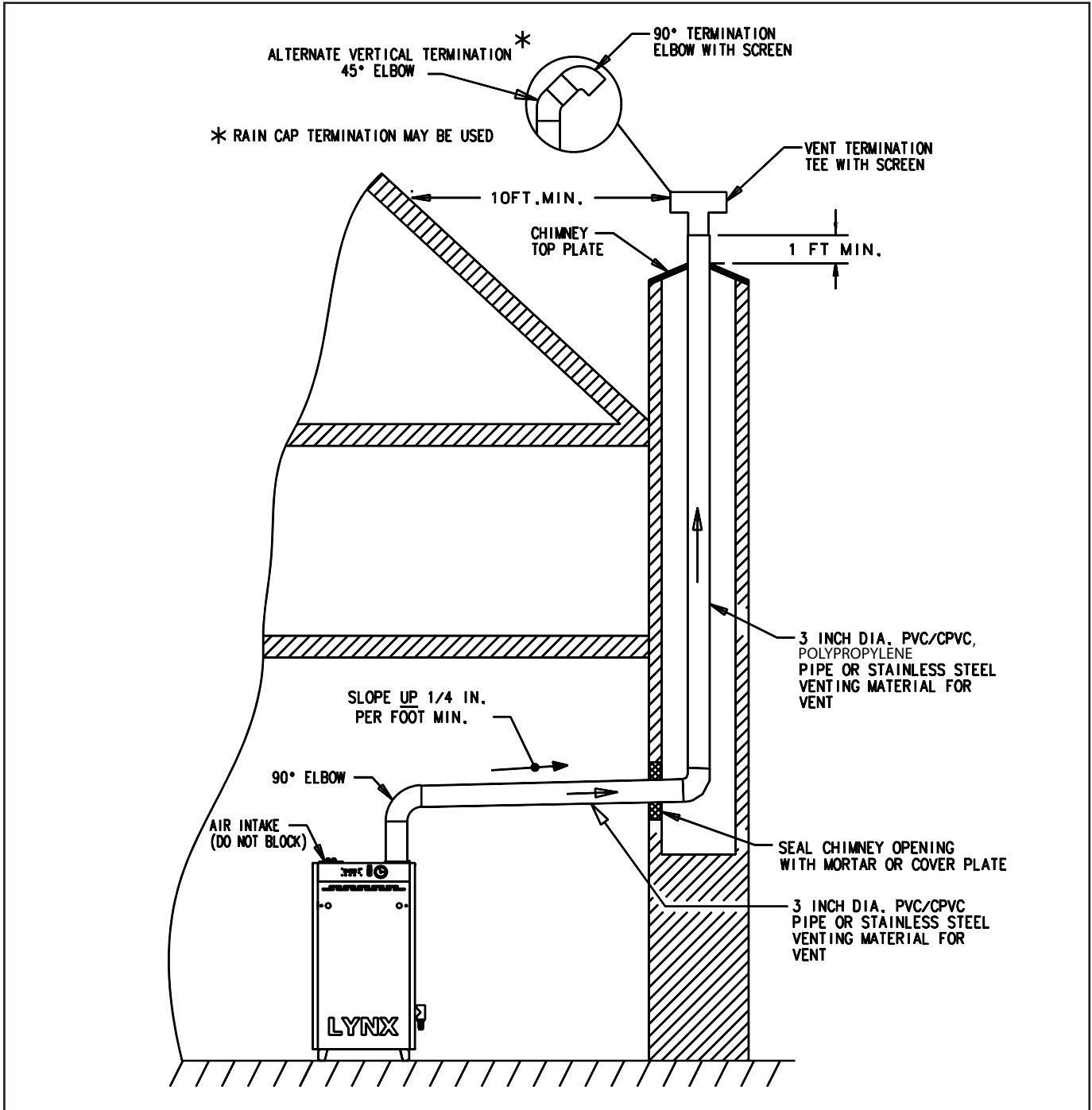

Figure 10. Lynx - non-direct vent, utilizing an existing chimney as a chase.

\* AL 29-4C IS A REGISTERED TRADEMARK OF ALLEGHENY LUDLUM CORP.

### DIRECT VENT, SIDEWALL VENTING

All joints must be liquid and pressure tight. Use 3" dia. PVC/CPVC schedule 40 pipe, 3" nominal ID polypropylene or U/L listed single wall 3" dia. AL29-4C S.S.\*. venting materials (See page 7).

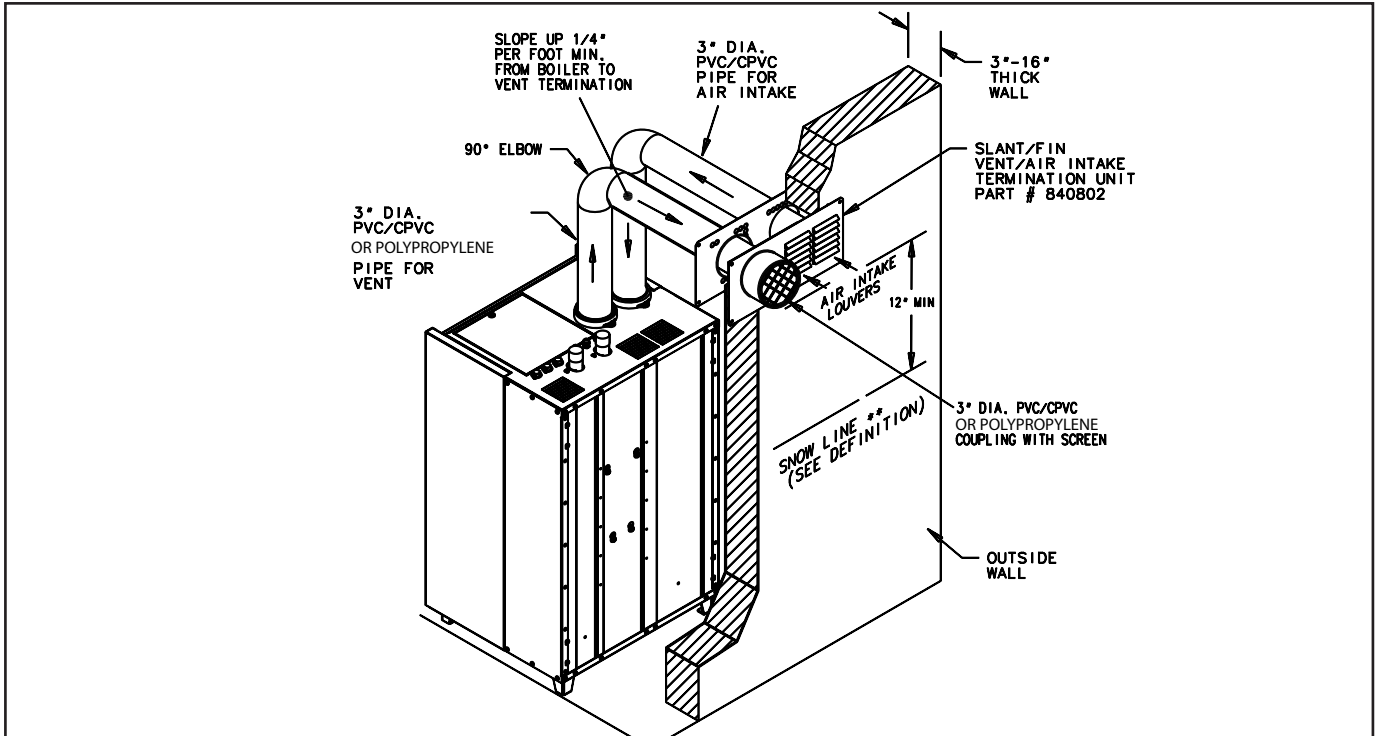

Figure 11. Direct vent, sidewall venting illustration; utilizing PVC/CPVC or polypropylene pipe for venting

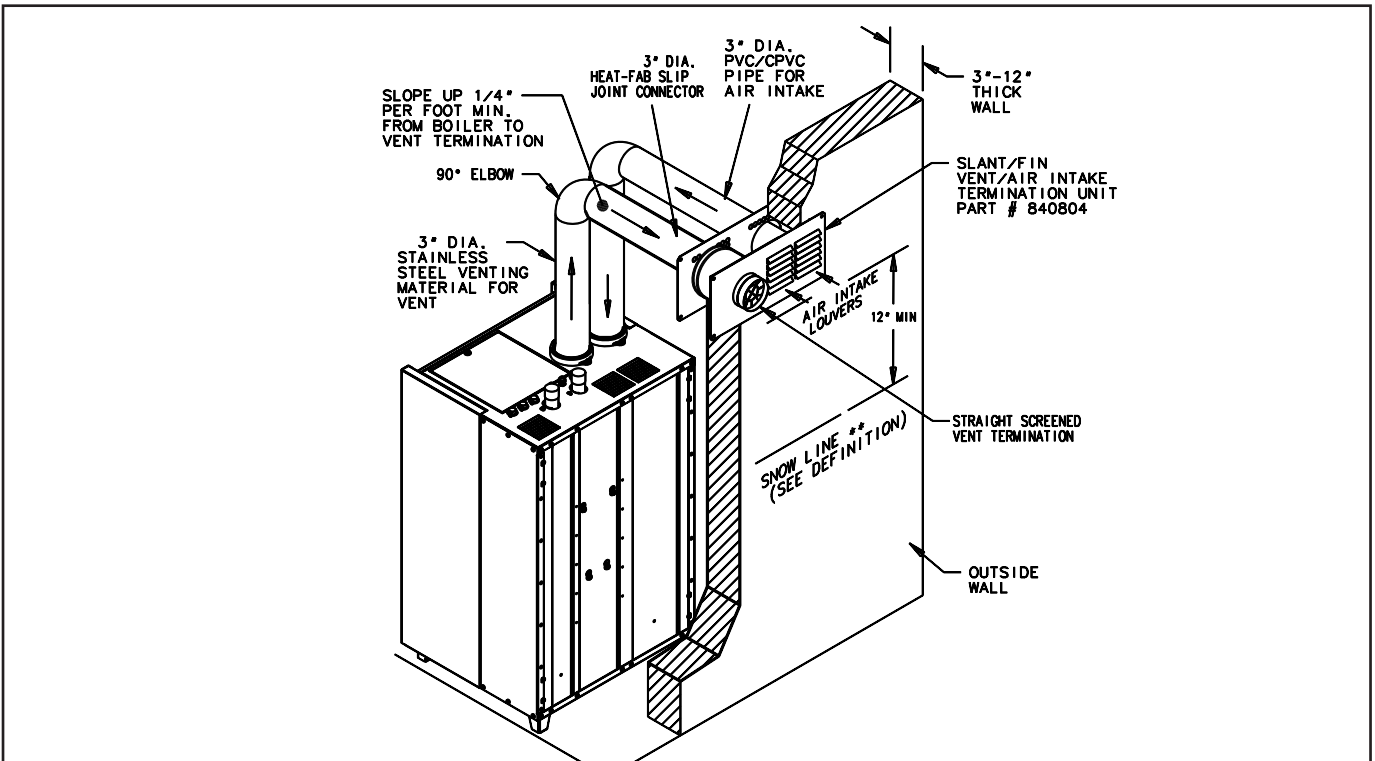

Figure 12. Direct vent, sidewall venting illustration; utilizing stainless steel vent materials for venting.

\*\* Definition of Snow Line: Knowledge of local conditions will reveal the maximum height that repeated snowfalls accumulate to. The height should be used as the SNOW LINE.

\* AL 29-4C IS A REGISTERED TRADEMARK OF ALLEGHENY LUDLUM CORP.

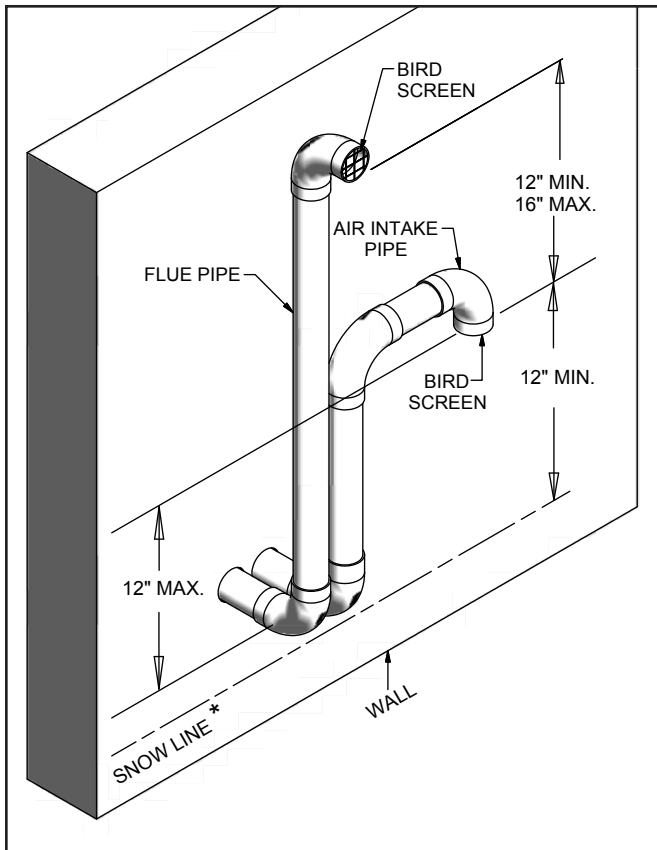

Figure 12a. Sidewall venting and air intake piping (snorkel style)

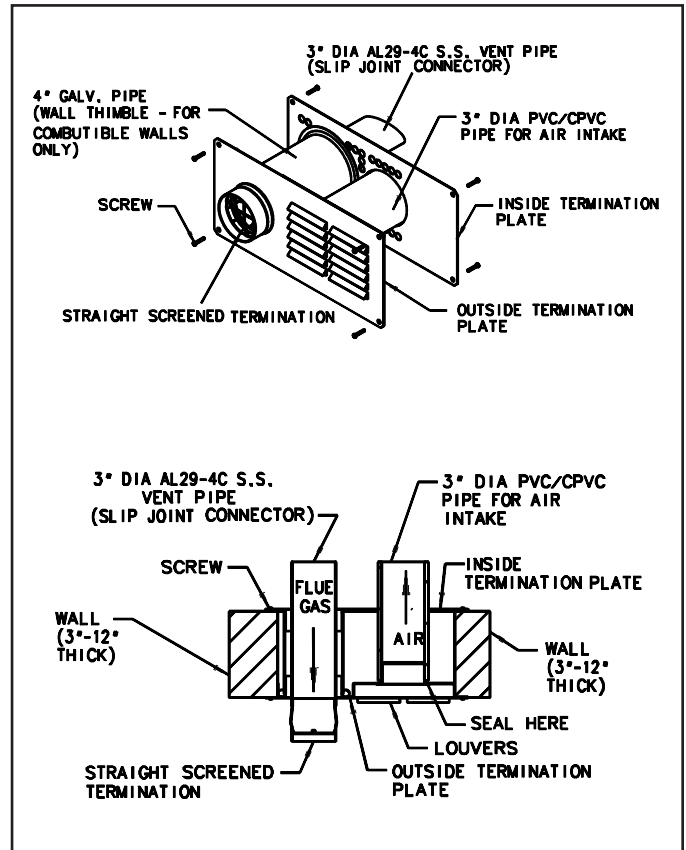

Figure 13b. Vent/Air intake termination; utilizing stainless steel venting materials.

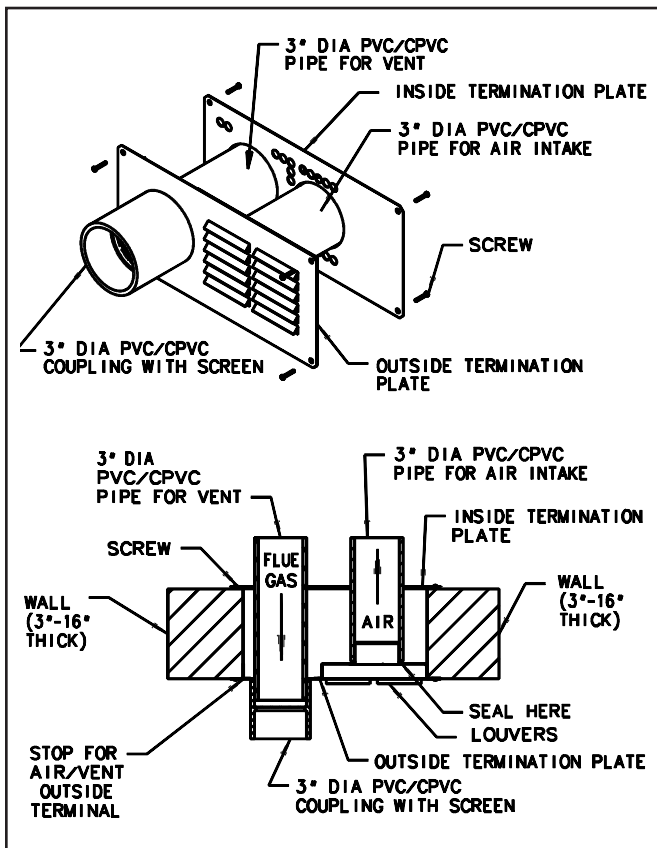

Figure 13a. Vent/Air intake termination; utilizing PVC/CPVC pipe for venting.

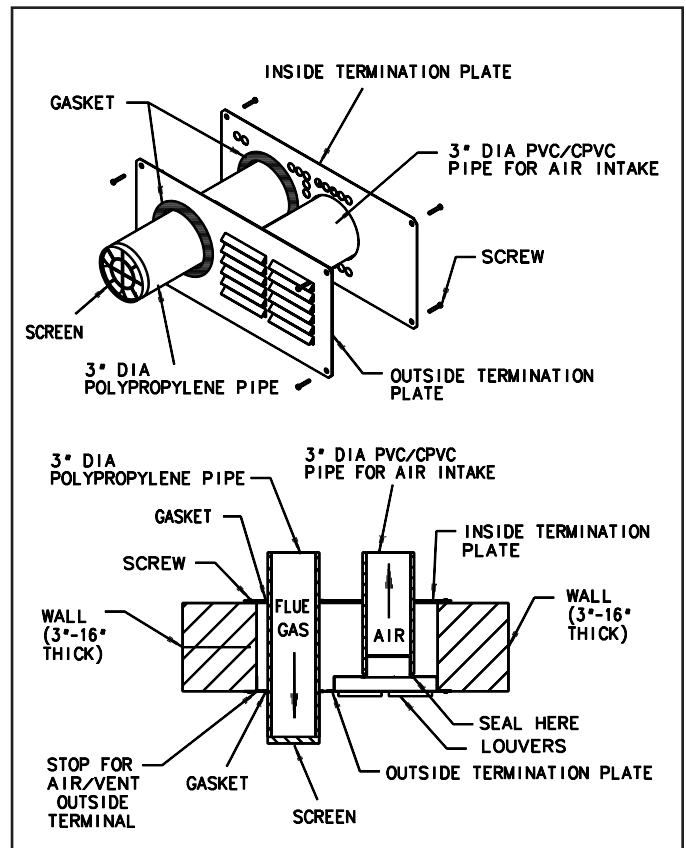

Figure 13c. Vent/Air intake termination; utilizing polypropylene pipe for venting.

### VENT/AIR INTAKE TERMINATION FOR PVC/CPVC, OR POLYPROPYLENE VENTING INSTALLATION (P# 840802000)

This termination is designed specifically for 3" diameter PVC, CPVC Schedule 40 or polypropylene pipe to be used as the vent and air intake piping material, only. It can be used on a combustible wall, provided the 1" minimum clearance of the vent pipe to any combustible surface is maintained.

1. Termination must be installed horizontally.
2. Refer to Figure 13a or 13c for installation details.
3. Wall thickness should be 3" to 18" thick.
4. Follow instruction for "vent termination location and clearances" explained on page 10.
5. Cut a rectangular opening with the following dimensions in the wall.  
Height: 5¼"  
Width: 12¾"
6. From outside of the wall, install outside termination plate using 4 screws. Make sure the louvers are at right side. Seal the plate perimeter with silicon.
7. Apply a bead of silicon around the outer surface of the outside termination plate air intake collar, about 1/2" from the edge. This will seal the air intake pipe to the air intake collar, in step #9.
8. From inside, install the inside termination plate, using 4 screws. Make sure that the holes for the vent and air intake pipe visually line up with the vent passage hole and air intake collar on the outside termination plate.
9. Cut the PVC or CPVC air intake pipe to the proper dimension to fit onto the air intake collar of the terminal. Slide the air intake pipe through the inside termination plate and onto the air intake collar, where the sealant was pre-applied in Step #7.
10. Cut the vent pipe so that it will extend out at least 2" from outside termination plate and 2" from the inside termination plate.
11. Cement a 3" diameter PVC or CPVC coupling onto the PVC or CPVC vent pipe, and install stainless steel screen into the coupling (supplied with the boiler).
12. From outside the wall, insert the bare end of the PVC or CPVC vent pipe through the outside and inside terminal plates, until the coupling is flush with the outside wall plate.
13. From inside, proceed with the air intake and vent pipe installation. Follow the proper PVC/CPVC assembly practices specified on page 8, and venting system restrictions specified on page 8 of this manual.

**Note: For venting with polypropylene pipe, special gasket (P# 813005000) must be added to inside and outside plate as shown on figure 13c.**

### VENT/AIR INTAKE TERMINATION FOR STAINLESS STEEL VENTING INSTALLATION (P# 840804000)

This termination is designed specifically for Heat-Fab Saf-T vent 3" diameter stainless steel venting system to be used as the vent, and 3" diameter PVC or CPVC schedule 40 pipe to be used as the air intake piping material, only. It can be used on a combustible wall, provided a length of 4" diameter galvanized pipe is installed as a thimble around the vent pipe, for the wall passage.

1. Termination must be installed horizontally.
2. Refer to Figure 13b for installation details.
3. Wall thickness should be 3" to 12" thick.
4. Follow instruction for "vent termination location and clearances" explained on page 10.
5. Cut a rectangular opening with the following dimensions in the wall.  
Height: 5¼"  
Width: 12¾"
6. From outside of the wall, install outside termination plate using 4 screws. Make sure the louvers are at right side. Seal the plate perimeter with silicon.
7. Apply a bead of silicon around the outer surface of the outside termination plate air intake collar, about 1/2" from the edge. This will seal the air intake pipe to the air intake collar, in step #11.
8. For combustible wall a 4" galvanized pipe must be used as a wall thimble. The length of the 4" galvanized pipe should be approximately 1" shorter than the wall thickness.
9. From inside the building, fit galvanized pipe over 4" collar of the outside plate.
10. From inside, install inside termination plate using 4 screws. Make sure the 4" collar on the plate, penetrated into the galvanized pipe.
11. Cut the PVC or CPVC air intake pipe to the proper dimension to fit onto the air intake collar of the terminal. Slide the air intake pipe through the inside termination plate and onto the air intake collar, where the sealant was pre-applied in Step #7.
12. Assemble and seal straight screened termination to the slip joint connector.
13. From outside of the building, insert vent pipe (slip joint connector and termination assembly) through the 3" holes of the outside and inside termination plate.
14. From inside, proceed with air intake and vent pipe installation. Follow vent manufacturer's instructions and restrictions specified on page 8 of this manual.



**B. DIRECT VENT - VENTING AND AIR INTAKE THROUGH A ROOF**

Figure 14 shows typical vertical venting. The vent pipe must pass through the ceiling, floor and the roof vertically through a 6" minimum diameter cutout. A fire stop is required for each ceiling and floor penetration. For roof passage an appropriate UL listed roof flashing must be used.

The vertical vent piping must terminate with a screened straight termination. The air intake termination should be a screened 180° elbow facing down. The air intake opening must be at least 1 foot below the vent opening.

For PVC/CPVC pipe, follow the proper assembly practices specified on page 8, and venting system restrictions specified on page 8 of this manual. For stainless steel venting systems, follow the vent manufacturer's instructions and the restrictions specified on page 8 of this manual.

Alternate air intake for venting through a roof (see fig. 14) or utilizing an existing chimney as a chase (see fig. 10): Air intake may be piped to the boiler from the sidewall as shown on figure 14a.

**DIRECT VENT, VENTING AND AIR INTAKE THROUGH A ROOF**

All joints must be liquid and pressure tight. Use 3" dia. PVC/CPVC schedule 40 pipe, 3" nominal polypropylene pipe or U/L listed single wall 3" dia. AL29-4C S.S.\*. venting materials (See page 7).

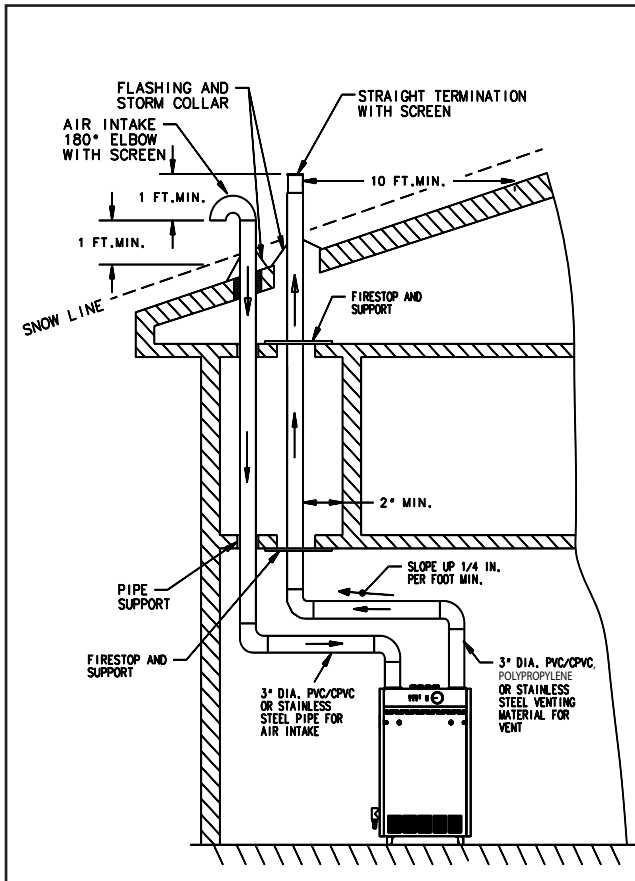

Figure 14. Direct vent, venting and air intake through a roof.

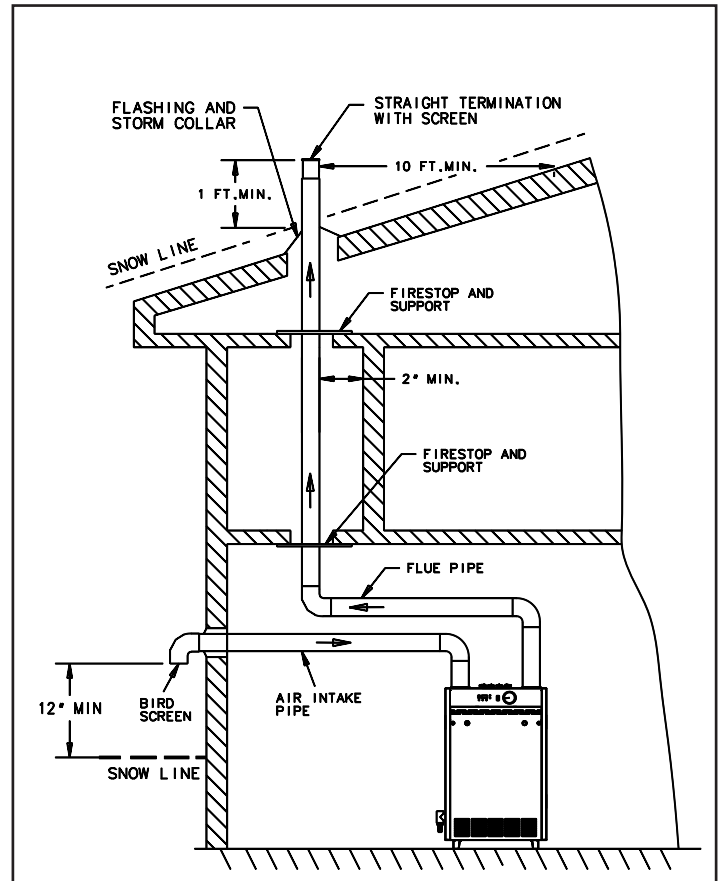

Figure 14a. Direct vent, venting through a roof and air intake sidewalls.

\*\* Definition of Snow Line: Knowledge of local conditions will reveal the maximum height that repeated snowfalls accumulate to. The height should be used as the SNOW LINE.

\* AL 29-4C IS A REGISTERED TRADEMARK OF ALLEGHENY LUDLUM CORP.

## VENTING AND AIR INTAKE SYSTEM REGULAR INSPECTION

- A. Inspect the system regularly for condensation, corrosion, sagging and/or physical damage. A qualified professional should service the boiler annually and include such an inspection at that time. The homeowner should look over the system monthly for damage, water stains, any signs of rust, other corrossions or separation of the vent and air intake piping (if direct-vent).
- B. Should an inspection turn up signs of condensation, corrosion, sagging or damage, the boiler should be shut down immediately and the condition should be corrected by a qualified professional.

## CONDENSATE REMOVAL SYSTEM

Lynx boilers are equipped with a built-in condensation drain and trap. The trap must be filled with water. DO NOT operate the boiler without filling the trap with water to prevent flue gas discharge into space. Periodic inspection should be made of this assembly for deterioration of the tubing and to insure that the trap is not plugged. If it is plugged or appears to have excessive sediment in it, it should be removed from the drain assembly, straightened out to clear the obstruction, reformed, filled with water and reinstalled as before.

A 3/4" PVC tee, located on the right side of the boiler jacket, is provided to run the condensate liquid from the boiler. Connect the plastic tubing that will be run to the drain to the bottom take-off of the tee. Leave the top take-off of the tee open, to act as a vacuum breaker. If the building drain is above the bottom portion of the tee, a condensate removal pump will be required. This pump must have an overflow switch, and be compatible with the acidic condensate liquid, as must all fittings and the tubing used in this condensate removal system. (See Figure 15).

No part of the condensate removal system can be exposed to freezing temperatures, or any other conditions that could cause blockage. DO NOT run drain tubing to the outside of the building. In addition, certain jurisdictions or drain pipe materials may require a neutralization unit to be installed in the condensate removal system. Any piping other than plastic types will be subject to corrosion or deterioration from the acidic condensate, which may have a pH level as low as 3.0. A condensate filter containing lime, marble, or phosphate chips can neutralize the condensate to a pH level

above 6.5, which is safe for all drain piping materials. (See Figure 15). The neutralizing filter medium will require periodic changing, to ensure it's affectiveness. Replacing the medium on an annual basis is recommended, or refer to the manufacturer's instructions for systems that are available for neutralizing condensate.

## COMMONWEALTH OF MASSACHUSETTS SPECIAL REQUIREMENT

When the Lynx is installed and used in the Commonwealth of Massachusetts, a neutralization unit **MUST** be installed in the condensate removal system.

## GAS PIPING

- A. Local installation codes apply. The pipe joint compound used on threads must be resistant to the action of liquefied petroleum gases.
- B. The gas supply line to the boiler should run directly from the meter for natural gas or from the fuel tank for L.P. propane gas. A manual gas supply shut-off valve is provided on the boiler's gas supply pipe. (See Figure 2, on page 3). Local codes may specify a manual main gas supply shut-off valve to be 5' above the floor, and a disconnection union at the gas piping entrance to the boiler. In this case, unless the boiler is wall mounted at the right height, the gas supply shut-off valve must be relocated to the specified location. If the gas supply pipe must be upsized for flow considerations, then the same size main gas supply shut-off valve must be used.

### Selecting pipe size for natural gas:

1. Measure or estimate the length of piping from the meter to the installation site.
2. Consult gas supplier for heating value of gas (Btu/cu. ft.).
3. Divide boiler rated input by heating value to find gas flow in piping (cu. ft. per hour).
4. Use table below to select proper pipe size.

**EXAMPLE:** Boiler model LX-120 is to be installed. Distance from gas meter to the boilers is 30ft. Heating value of natural gas is 1020 Btu/cu. Ft. Select proper pipe size.

$$\text{Gas flow} = \frac{120,000 \text{ Btu/hour}}{1020 \text{ Btu/cu. ft.}} = 118 \text{ cu. ft. per hour}$$

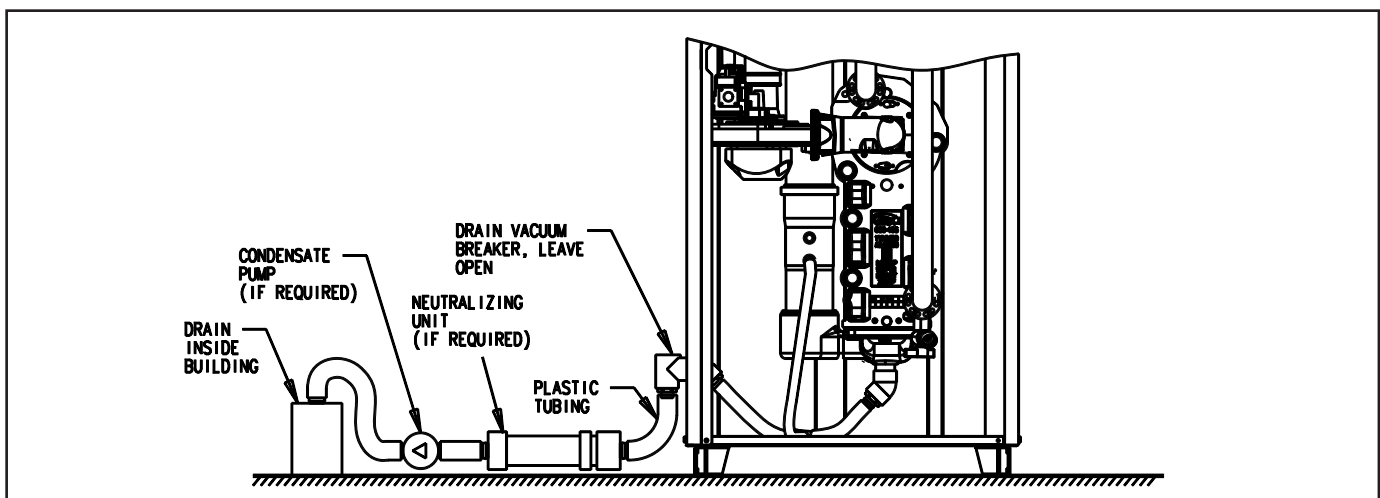

Figure 15. Condensate disposal system

At 30 ft. length of pipe, match required capacity from table on this page (choose higher capacity, in this case is 152 cu. ft. per hour). Required pipe size is 3/4".

Improper gas pipe sizing will result in flame outages, insufficient heat and other installation difficulties. For more information and also if other appliances are to be attached to the piping system, see Appendix C of National Fuel Gas Code ANSI Z223.1-latest edition.

- C. The boiler and its gas connection must be leak tested before replacing the boiler in operation. Use liquid soap solution for all gas leak testing. DO NOT use open flame. This boiler and its individual shutoff valve must be disconnected from the gas supply piping system during and pressure testing of that system at test pressures in excess of 1/2 PSIG. This boiler must be isolated from the gas supply piping system by closing its individual manual shutoff valve during any pressure testing of the gas supply piping system at test pressures equal to or less than 1/2 PSIG.
- D. All gas piping used should be inspected thoroughly for cleanliness before makeup. A sediment trap is integrally provided, as illustrated on page 3.
- E. The minimum and maximum gas supply pressure (at the inlet of gas valve) are shown on the boiler rating plate for the type of gas used. Gas supply pressure should never be less than minimum or more than maximum pressure when the boiler or any other appliance is turned on or off.

| Length of pipe in Feet | Gas Flow In piping -- cu. ft. per hr. |     |     |       |       |
|------------------------|---------------------------------------|-----|-----|-------|-------|
|                        | Iron Pipe Size (IPS) — inches         |     |     |       |       |
|                        | 1/2                                   | 3/4 | 1   | 1 1/4 | 1 1/2 |
| 10                     | 132                                   | 278 | 520 | 1050  | 1600  |
| 20                     | 92                                    | 190 | 350 | 730   | 1100  |
| 30                     | 73                                    | 152 | 285 | 590   | 890   |
| 40                     | 63                                    | 130 | 245 | 500   | 760   |
| 50                     | 56                                    | 115 | 215 | 440   | 670   |
| 60                     | 50                                    | 105 | 195 | 400   | 610   |
| 70                     | 46                                    | 96  | 180 | 370   | 560   |
| 80                     | 43                                    | 90  | 170 | 350   | 530   |
| 90                     | 40                                    | 84  | 160 | 320   | 490   |
| 100                    | 38                                    | 79  | 150 | 305   | 460   |

At pressure drop of 0.3 in. water, specific gravity = 0.6.

**ELECTRICAL WIRING**

All field wiring to the boiler is connected to the 2 sets of terminal strips, located under the jacket top panel. (See Figure 2, on page 3)

**DANGER:** Before wiring always turn off electric power supply. Otherwise, shock or death can result.

- 1. **Power Supply**  
A separately fused circuit is recommended. Use standard 15 Amp. fuse or breaker and 14 gage conductors in BX cable or conduit.  
  
Provide disconnect means and overload protection as required. See boiler wiring diagram (Figure 16a) boiler control (Figure 16b) and ladder diagram (Figure 16c).

Boiler must be electrically grounded in accordance with the requirements of the authority having jurisdiction, or, in the absence of such requirements, with the National Electrical Code, ANSI/NFPA 70-latest edition.

Proper polarity is critical for the power supply connections. Reversed polarity will cause system lockout. Proper grounding is critical for boiler operation, connect the ground wire to the green ground screw next to the line voltage terminal strip.

- 2. **Circulator(s)**  
A set of terminals are provided for the boiler (primary loop) circulator. Only wire this circulator to these terminals, additional (secondary loop) circulators for space heating require the use of relays and a separate power source.

For multiple zoning, either zone valves or circulators maybe used.

For zone valve system (See Figure 17a).

For pump zoning system (See Figure 17b and 17c).

DO NOT use boiler transformer to power external accessories like zone valve and relays, overload and/or burned out transformer and boiler malfunction can result. Use separate transformer to power such components.

A second set of terminals are provided for the domestic hot water tank circulator (if used). The primary loop circulator is always de-energized when the DHW tank circulator is energized, for priority.

- 3. **SPACE HEATING THERMOSTAT(S)**  
Install thermostat on an inside wall and away from any heat sources, sunshine and drafts. A set of terminals are provided for connection of 24 volt style thermostats, relays or zone valve end switches (isolated contacts). (See wiring diagram Figure 16a).

Thermostat heat anticipator: For a non-zoned system set thermostat heat anticipator to 0.1 Amps, for zoned system set to match power requirements of zone valves or relays. Refer to manufacturer's instructions and specifications. Also see instructions with thermostat.

- 4. **DOMESTIC HOT WATER TANK THERMOSTAT**  
A set of terminals are provided for connection of the DHW tank thermostat (if used). (See wiring diagram Figure 16a).
- 5. **OUTDOOR AIR SENSOR**  
A set of terminals are provided for connection of an outdoor air sensor (if this method is used). (See wiring diagram Figure 16a).

The outdoor air sensor must be a 12k ohm type. Mount on an outside wall, shielded from direct sunlight or flow of heat or cooling form other sources. See instructions provided with sensor.

- 6. **LOW WATER CUTOFF**  
A set of terminals are provided for connection of a LWCO. If this device is used, remove the factory installed jumper from these terminals. (See wiring diagram Figure 16a).

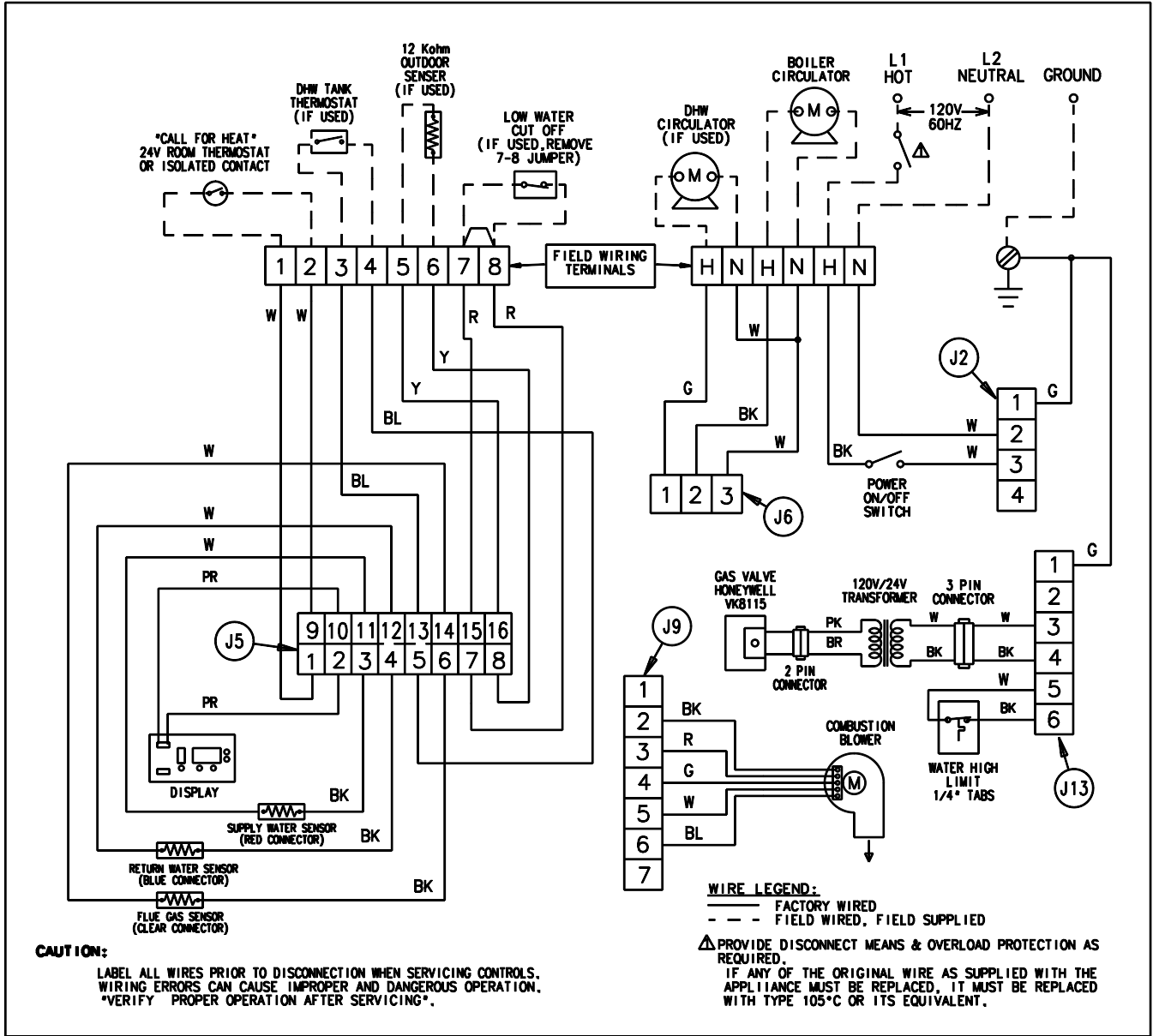

Figure 16a. Schematic wiring diagram.

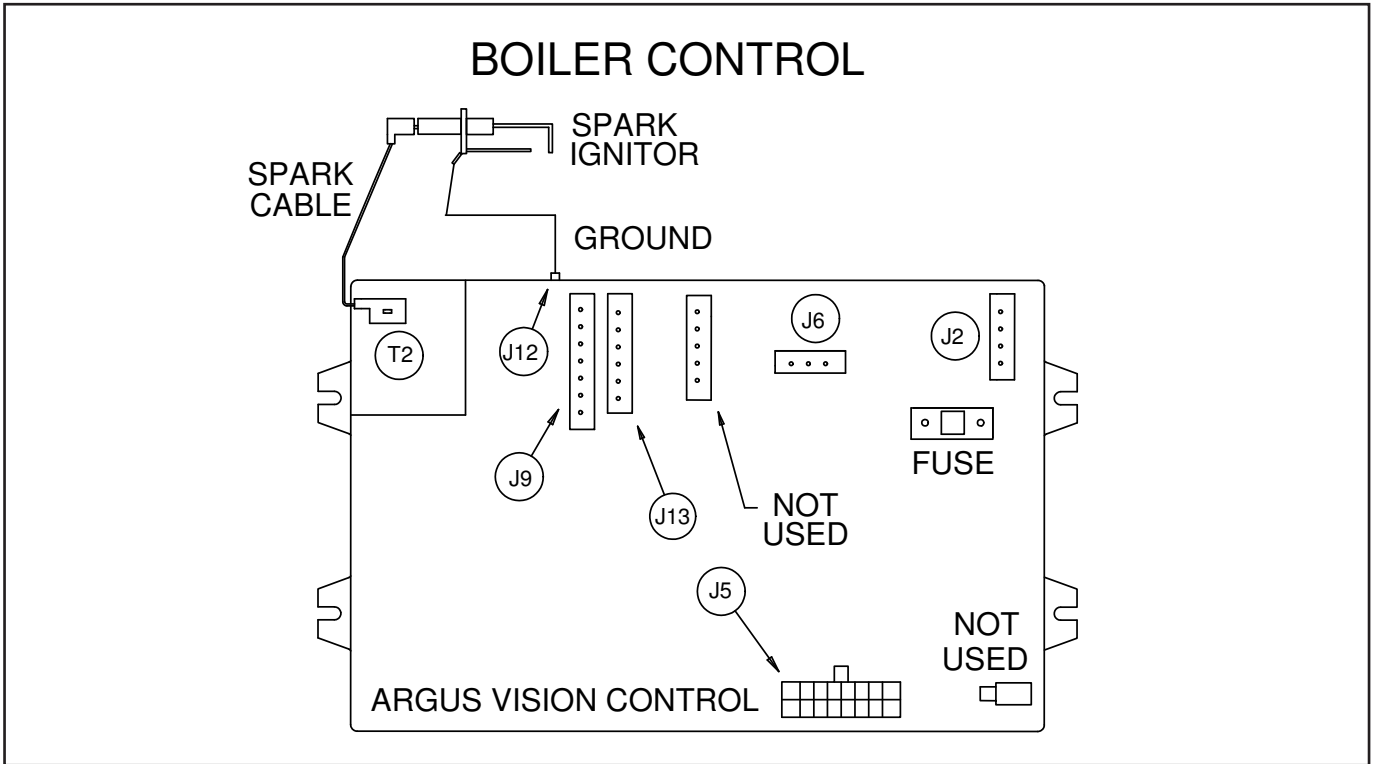

Figure 16b. Boiler Control.

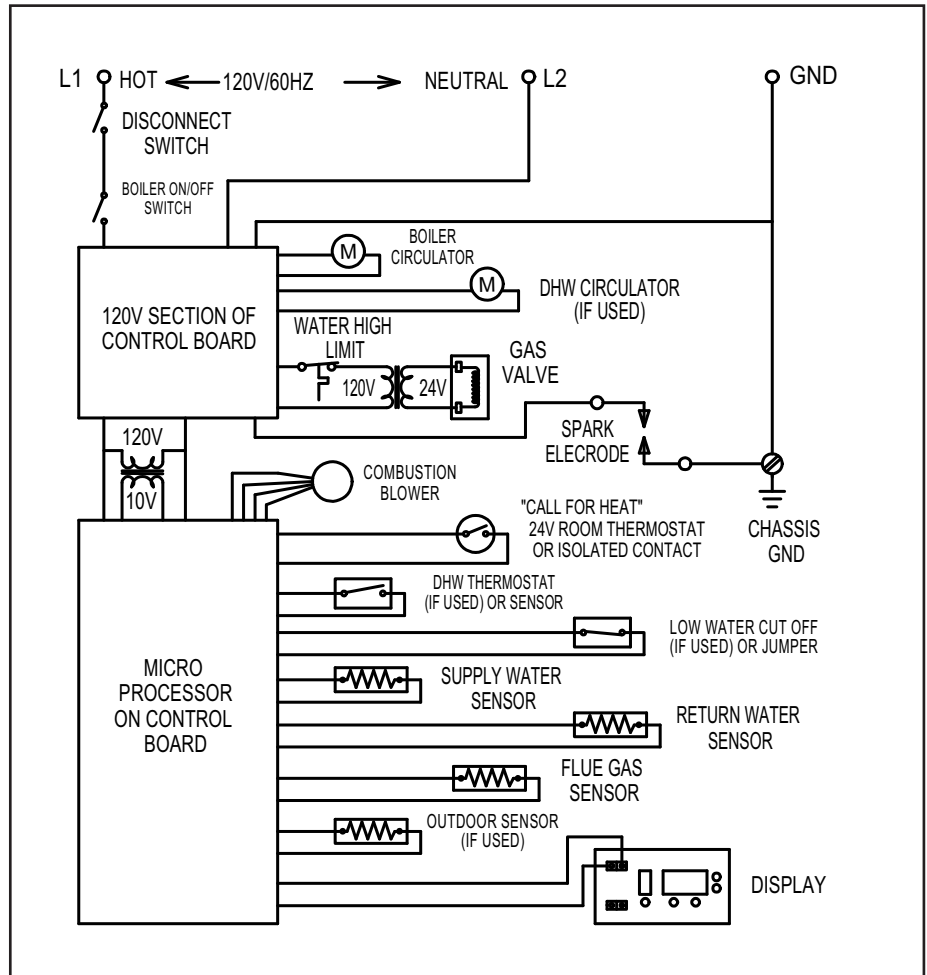

Figure 16c. Ladder wiring diagram.

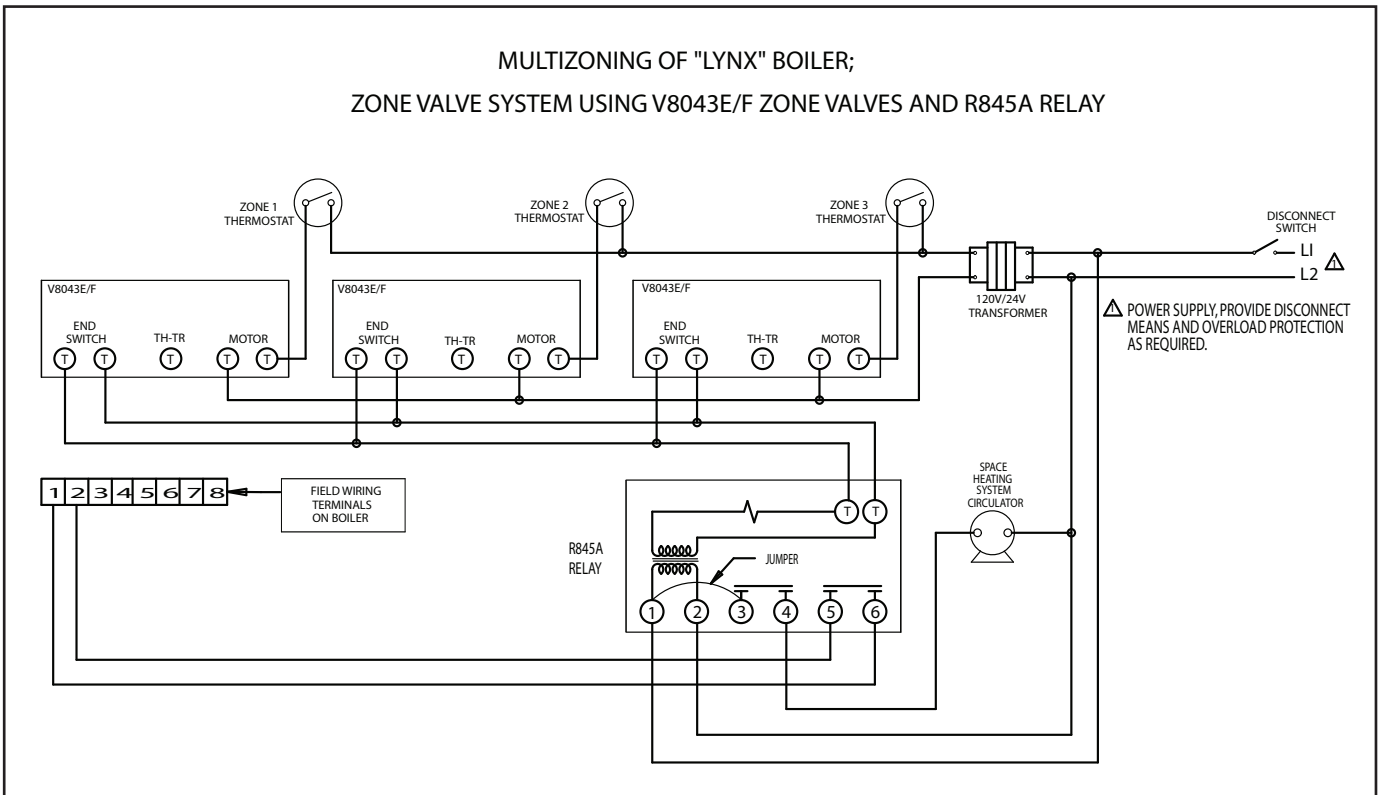

Figure 17a. Multizoning of Lynx boiler; zone valve system.

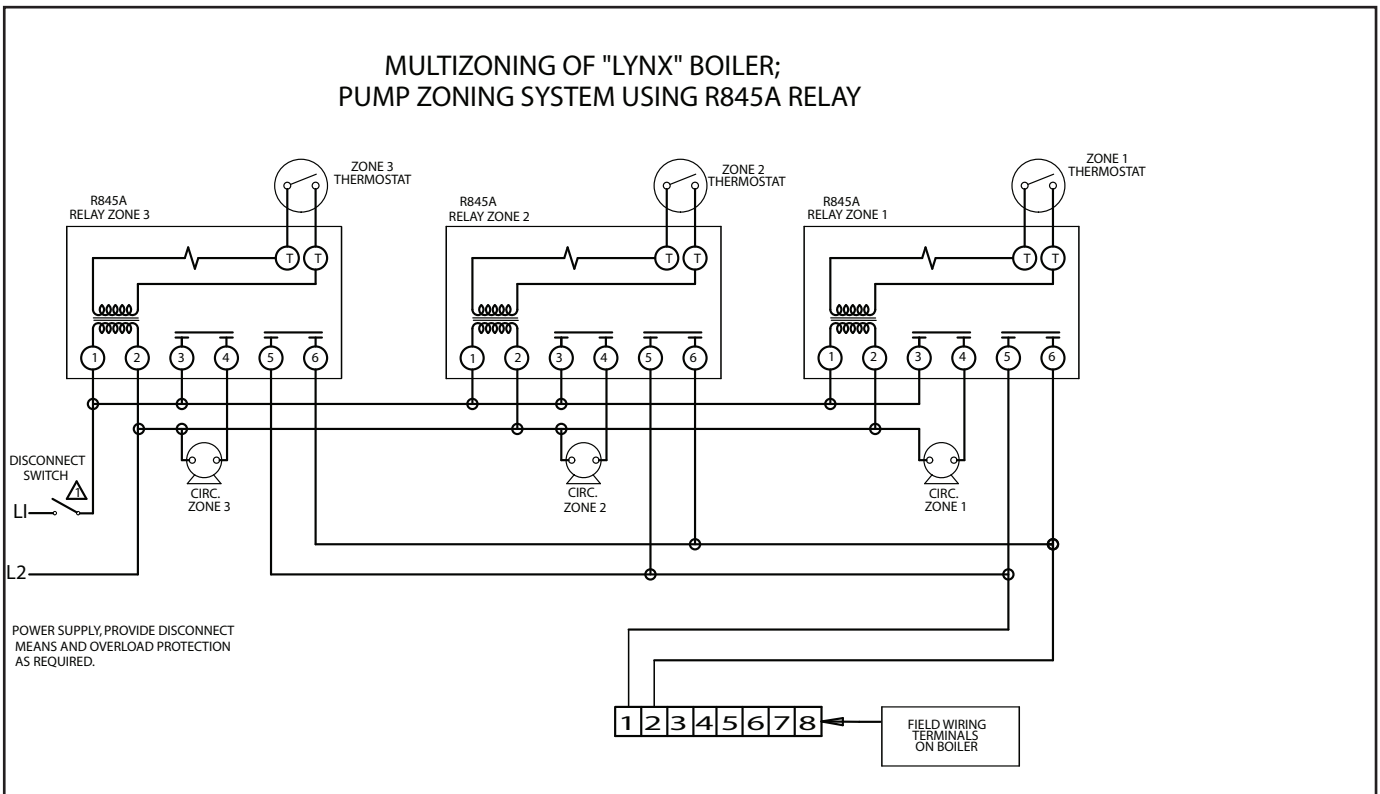

Figure 17b. Multizoning of Lynx boiler; pump zoning system using R845A relay.

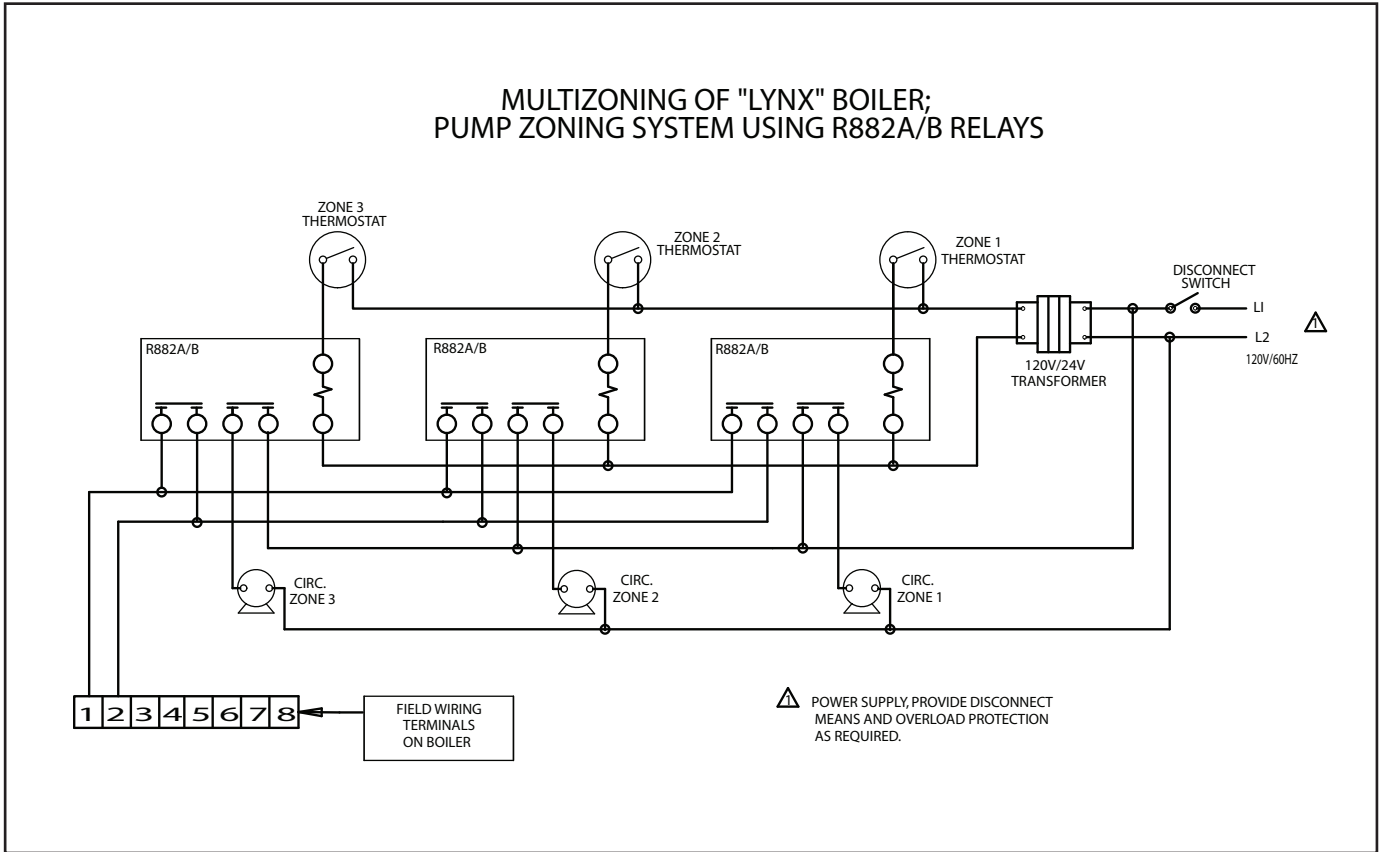

Figure 17c. Multizoning of Lynx boiler; pump zoning system using R882A/B relays.

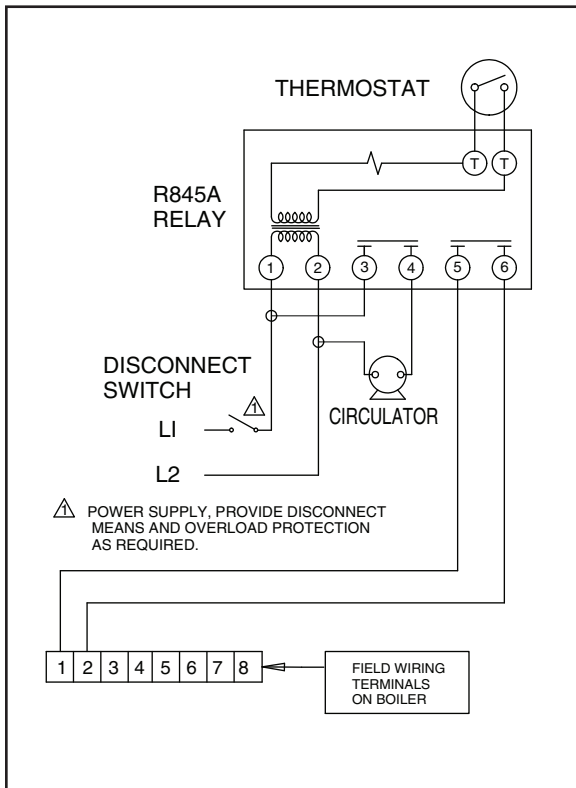

Figure 17d. Single zoning of Lynx boiler; pump zoning system using R845A relay.

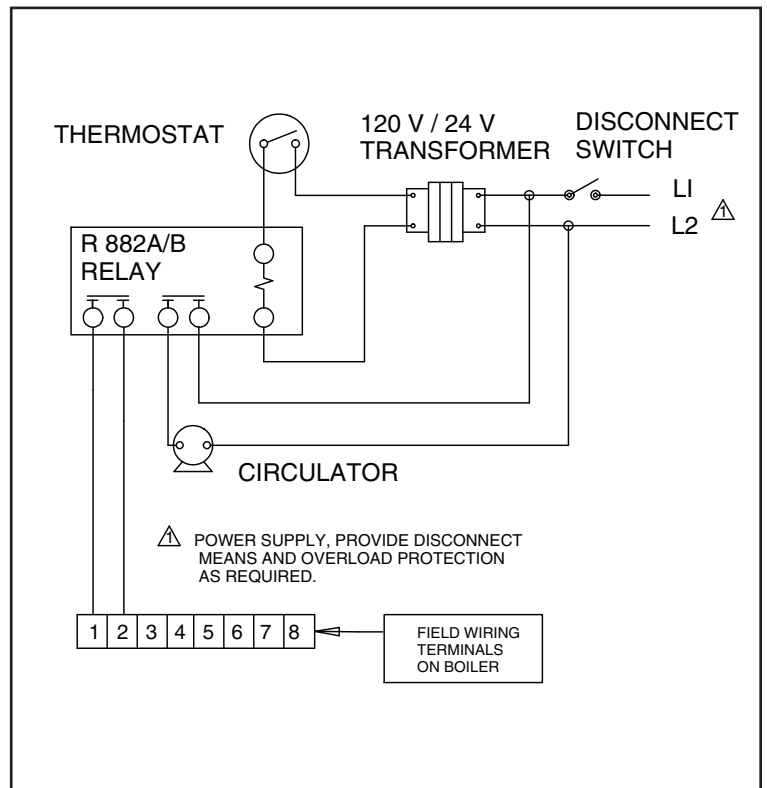

Figure 17e. Single zoning of Lynx boiler; pump zoning system using R882A/B relay.

## WATER PIPING

### A. Connection of system to boiler:

Primary/secondary piping should be used to ensure the proper flow through the boiler. (See Figures 20 through 22). The boiler loop piping must be the same diameter as the water outlet (supply) and inlet (return) piping connections provided on the boiler, particularly on longer loops. See page 2 for piping connection size.

### B. Circulator Pumps:

The boiler loop piping must utilize the Taco 0011 or Grundfos UPS 26-99F circulator that is supplied with the boiler, to ensure the proper flow through the boiler. Refer to Figure 19 for the boiler water side pressure drop and Table 2 for the recommended pump models for the domestic hot water system. Install the pumps in the orientation shown in Figures 20 through 22.

### C. Relief Valve(supplied with boiler):

Tee the relief valve into the boiler water outlet (supply) piping as close to the water outlet (supply) connection as possible. (See Figure 18). The relief valve's discharge piping must be the same size or larger than the relief valve's outlet, and must terminate 6" minimum from floor with a plain (no threads) end. Place a bucket under pressure relief valve discharge. Make sure discharge is always visible. DO NOT hard-pipe to drain piping, or any place where freezing could occur. No shut-off valve is permitted between the relief valve and boiler, or in the discharge line.

### D. Air Control System:

An appropriately sized diaphragm-type expansion tank must be used to control the system pressure. See boiler volume data on page 2, and the recommended location in Figures 20 through 22. An air vent is recommended to be installed on an air separator in close proximity to the expansion tank.

### E. Cold Water Fill:

A pressure reducing (fill) valve, with a shut-off valve upstream of it, should be installed in close proximity of the expansion tank. (See Figures 20 through 22). Use a back flow check valve in the cold water supply as required by local codes.

### F. Low Water Cutoff:

On a hot water boiler installed above radiation level, the boiler must be provided with a low water cutoff device at the time of installation by the installer (see Figure 18 for piping arrangement).

### G. Water Treatment and Freeze Protection:

A good water treatment program will not only extend the useful life of this boiler but it will also save much of the time and expense of repairs made necessary by preventable occurrences. A reputable water treatment company that has experience with aluminum boilers should be consulted to evaluate and determine the best overall treatment program for your boiler.

The heat exchanger of this boiler is made of aluminum, so the system water PH must be maintained between 7.5 and 8.5 level.

### Procedure:

1. Thoroughly drain and flush the system (new or used) with fresh water before connecting the boiler to the system to remove any sediment or glycol.
2. Install the boiler per instructions in this manual.
3. It is recommended to clean the heating system with proper cleaner. Do not use phosphate-based (TSP) cleaners, as they will harm aluminum heat exchanger. Follow manufacturer instruction. Rhomar Hydro-Solv 9100 is recommended (add approximately 1 gallon per 50 gallon of system water). Circulate cleaner for minimum of 1/2 hour, and then thoroughly flush until the water runs clear.
4. It is recommended to add system treatment (inhibitor). Do not use phosphate, nitrate or high pH products. Follow manufacturer instructions. Rhomar Pro-Tek 922 is recommended at the rate of 1 gallon per 50 gallon of system water.  
Note: Extra inhibitor may not be needed if using the approved antifreeze containing inhibitor additive as listed below.  
Test the PH of the water system annually, if the PH is out of the range (7.5-8.5), the inhibitor level may not be sufficient, add inhibitor to the system.
5. Anti-freeze is sometimes used in hydronic systems to protect against freeze-up in the event of power failure or boiler shut down in the cold winter.

Approved anti-freeze is RhoGard (propylene glycol with Pro-Tek 922 inhibitor) by Rhomar Water Management Inc. or Noburst AL by Noble. Follow the manufacturer's instructions for proper application and proper mixture for the minimum ambient temperature. Any use of anti-freeze other than that supplied by Slant/Fin or approved will void the warranty.

Notice: When adding less than 50% RhoGard antifreeze to a system, additional inhibitor should be added to ensure adequate corrosion protection.

Keep water hardness less than 7 grains/gallon. It is recommended to use water softener for hard water areas or if well water is used.

Never use Ethylene glycol, as it is toxic to humans. Never use any type of automotive or standard glycol freeze protection fluid. Do not exceed 50% by volume concentration of anti-freeze. Check anti-freeze concentration annually.

### H. Piping a heating - cooling system to a water boiler and chiller:

Figure 22 illustrates a method of piping a heating-cooling system to a water boiler and a chiller. Hand valves (shown) or automatic valves must be installed to prevent circulation of chilled water in the boiler or hot water in the chiller.

The air control system and pressure control system must operate with chiller only, or the boiler only, being valved to the piping system. Separate control devices on the boiler and chiller may be used, or a single set of air and pressure controls on the common piping may be preferred.

If the boiler is used to supply hot water to heating coils in air handling units, flow control valves or other devices must be installed to prevent gravity circulation of water in the coils during the cooling cycle.



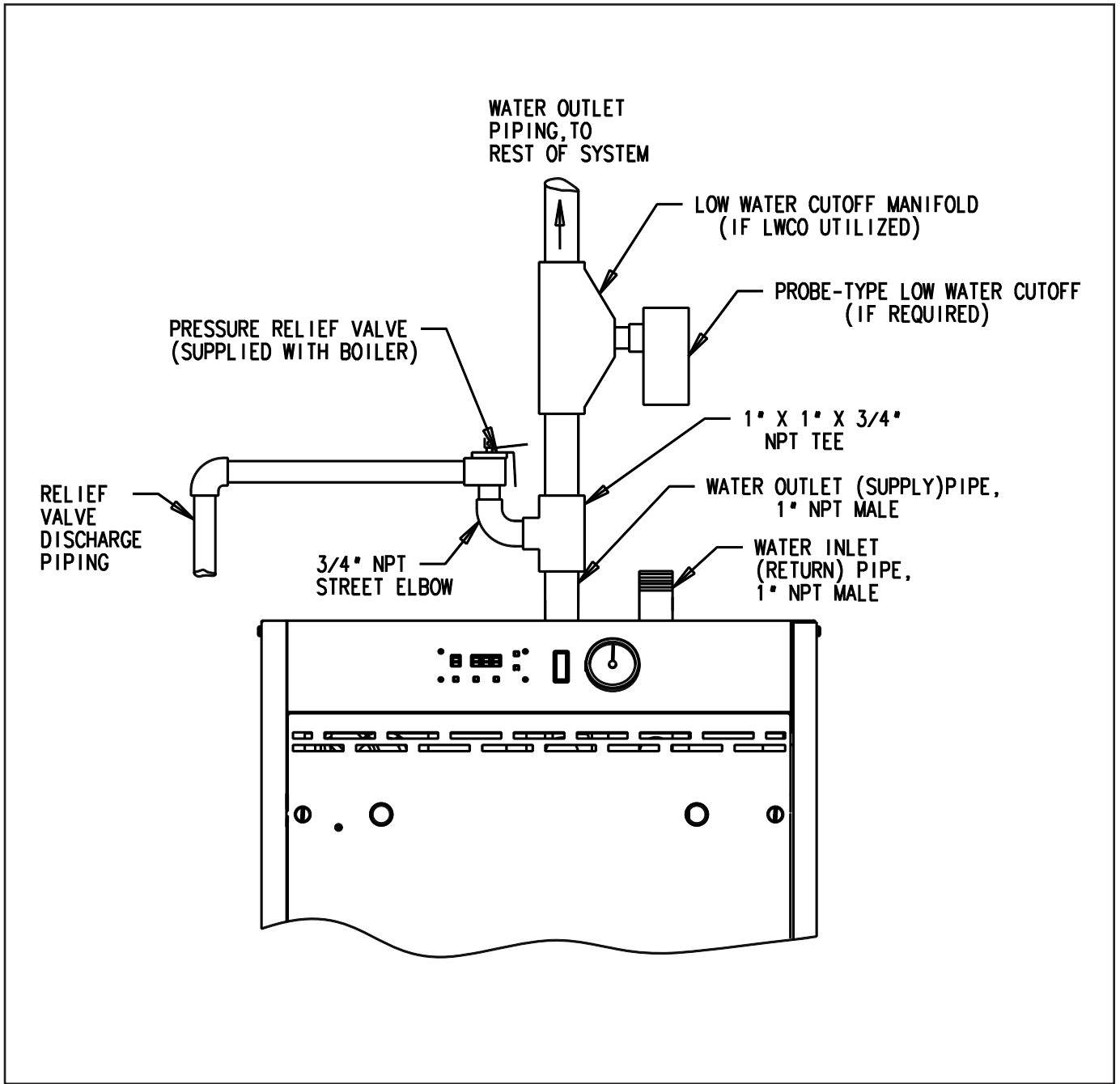

Figure 18. Relief Valve and Low Water Cutoff Installation

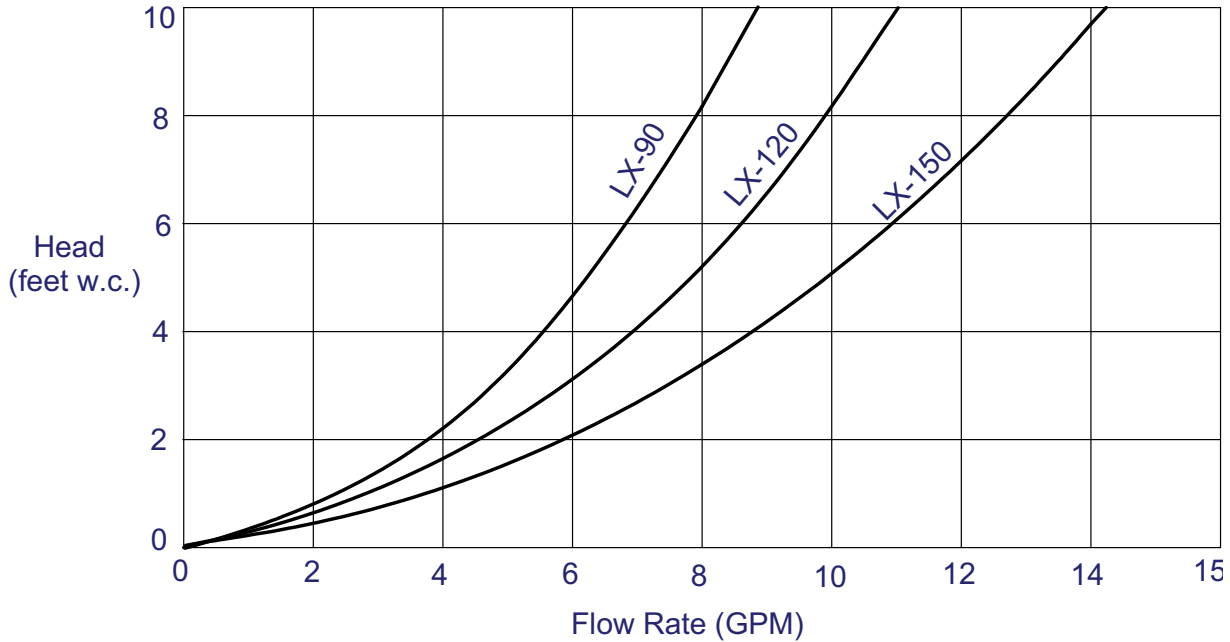

Figure 19. Boiler water side pressure drop

| Boiler Model No. | Flow Rate (gpm) | Temp Rise (°F) | Boiler Head Loss (Feet w.c.) | Domestic Water Tank Piping Head Loss ** (Feet w.c.) | Available Head Capability Left for Various Model Circulators to Overcome DHW Tank Head Loss (Feet w.c.) *** |                        |           |
|------------------|-----------------|----------------|------------------------------|---|---|------------------------|-----------|
|                  |                 |                |                              |   | Taco 0014   | Taco 0011 <sup>▲</sup> | Taco 0013 |
| LX-90            | 8.1             | 20             | 8.2                          | 2.5   | 7.3   | 14.1                   | 17.5      |
|                  | 6.5             | 25             | 5.4                          | 2.2   | 10.9  | 18.2                   | 22.2      |
|                  | 5.4             | 30             | 3.5                          | 2.0   | 14.0  | 21.3                   | 25.2      |
|                  | 4.0*            | 40             | 2.1                          | 1.5   | 16.4  | 23.9                   | 28.2      |
| LX-120           | 10.8            | 20             | 9.5                          | 3.0   | 4.5   | 11.4                   | 13.4      |
|                  | 8.6             | 25             | 6.6                          | 2.7   | 8.5   | 14.8                   | 18.7      |
|                  | 7.2             | 30             | 4.2                          | 2.5   | 11.5  | 18.3                   | 22.2      |
|                  | 5.4*            | 40             | 2.5                          | 1.5   | 15.5  | 23.0                   | 27.0      |
| LX-150           | 13.5            | 20             | 9.0                          | 3.5   | 2.7   | 7.5                    | 11.5      |
|                  | 10.8            | 25             | 6.0                          | 3.0   | 8.0   | 13.5                   | 17.5      |
|                  | 9.0             | 30             | 4.2                          | 2.5   | 11.0  | 17.0                   | 20.5      |
|                  | 6.8*            | 40             | 2.5                          | 2.0   | 14.0  | 21.5                   | 24.5      |

Table 2. Recommended pump models for domestic hot water tank piping.

Notes:

- \* This is the minimum flow rate recommended for the boiler.
- \*\* Domestic water tank piping head is based on 1" inside diameter piping and full port valves.
- \*\*\* Refer to the DHW Tank Manufacturer's water flow rate requirements and associated pressure drop head loss, to select the appropriate circulator.
- ▲ Or Grundfos UPS 26-99F.

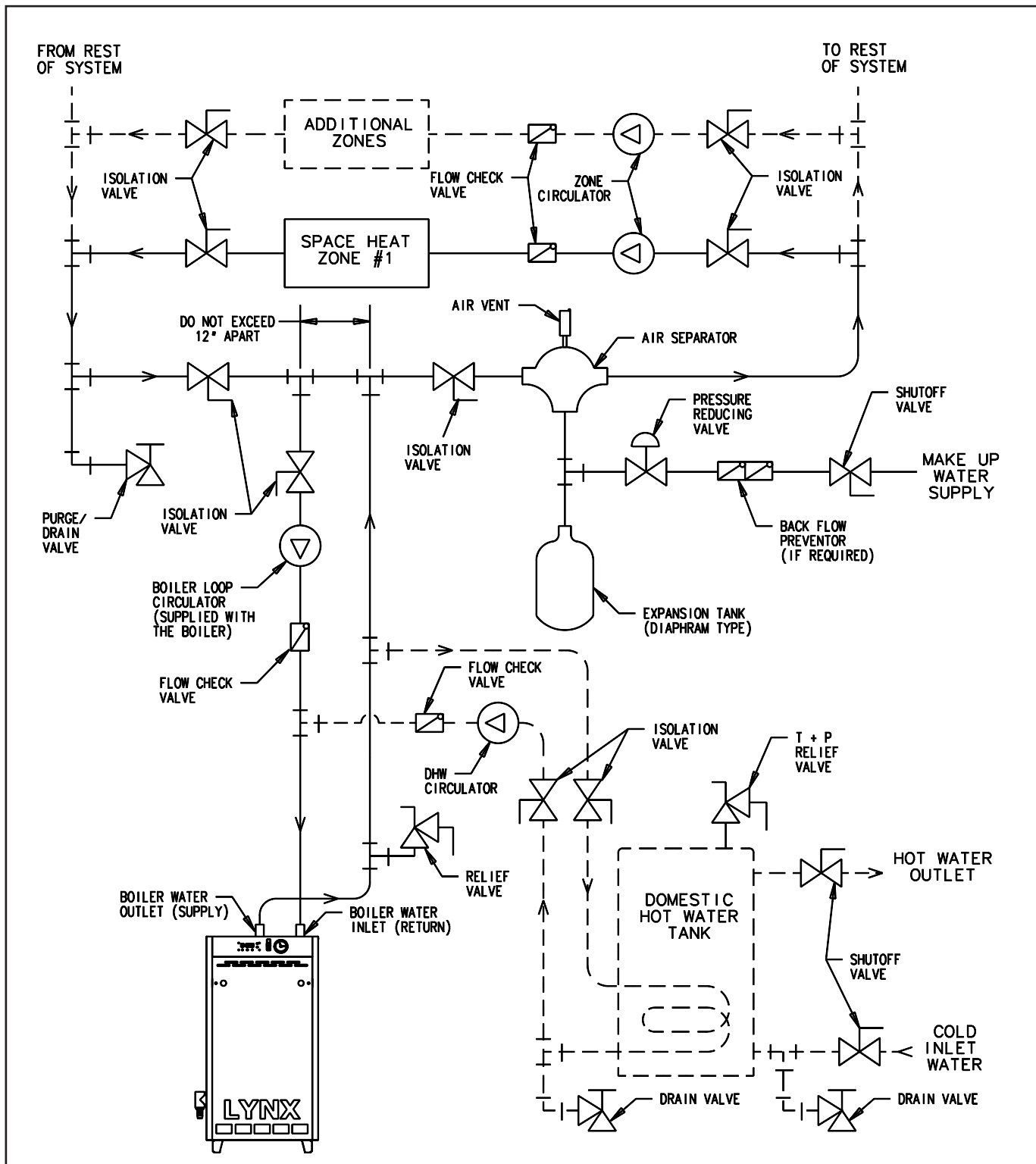

Figure 20. Zoning with circulators.

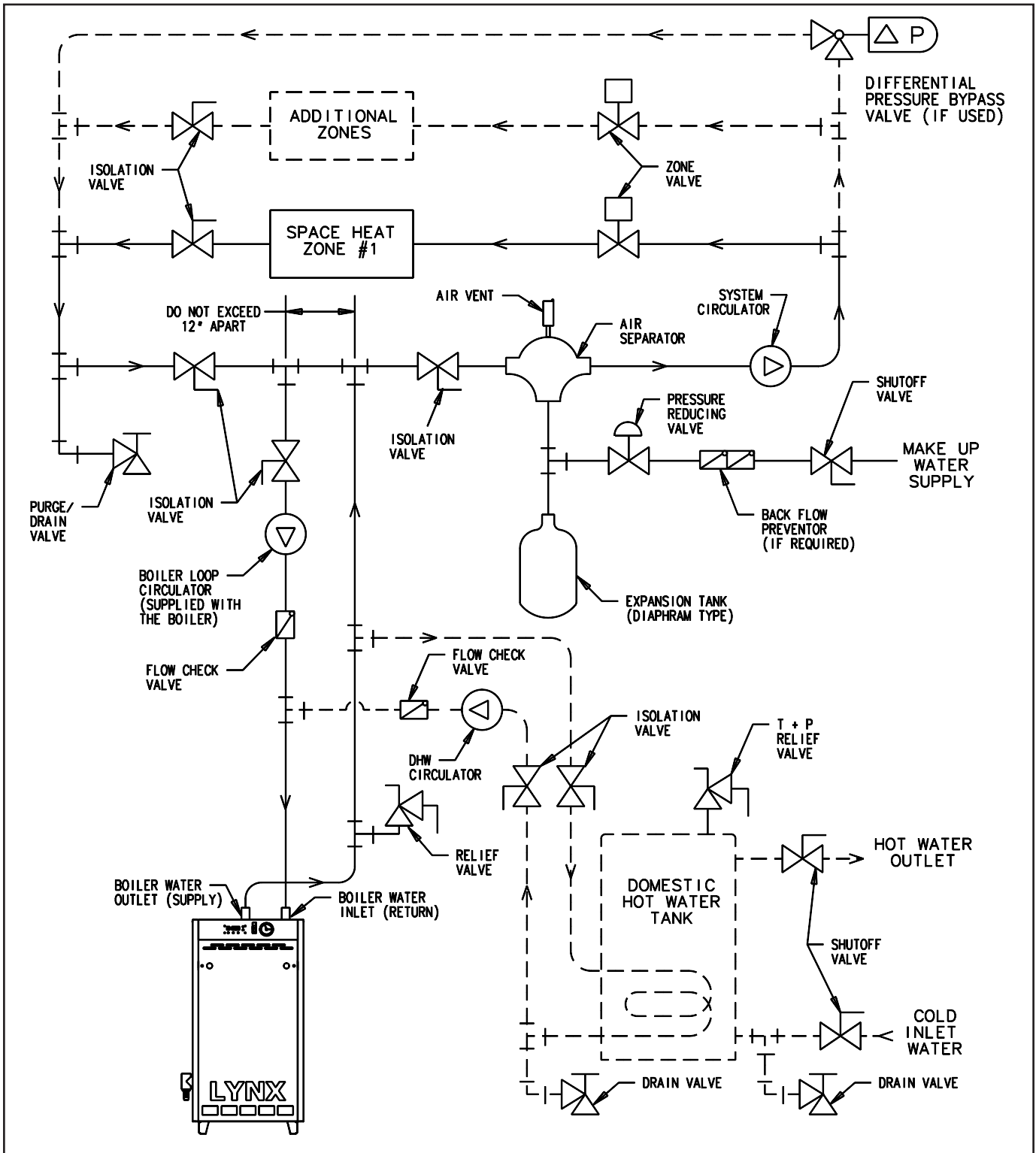

Figure 21. Zoning with zone valves.

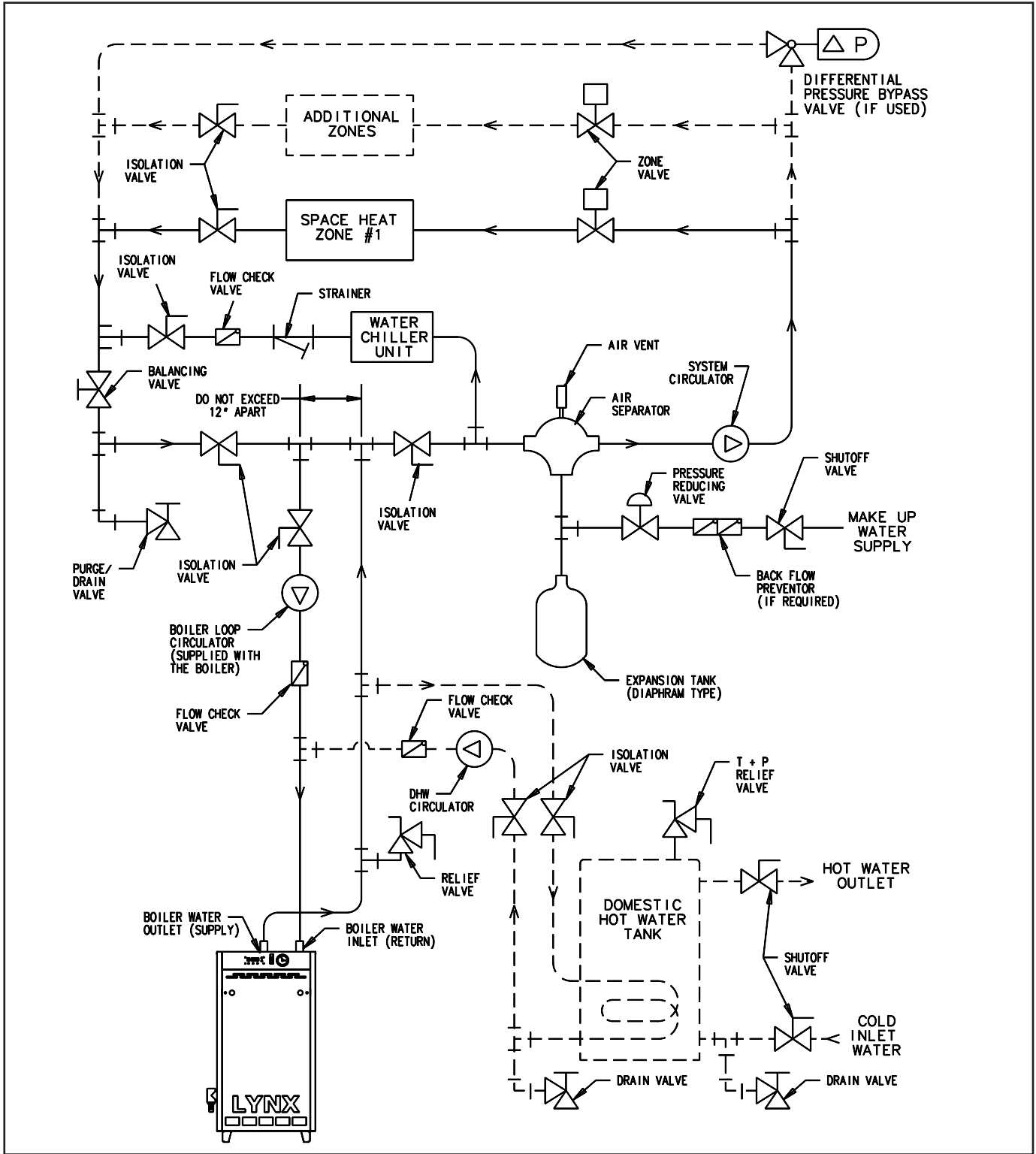

Figure 22. Piping a heating-cooling system to the boiler and a chiller.

## OPERATING INSTRUCTIONS

### I. FILLING AND VENTING WATER SYSTEMS

- A. Fill the system with water. Vent or purge of air.
- B. Fire the boiler as soon as possible (see following warning and instructions) and bring water temperature in the system.
- C. Vent air and add water as needed to achieve operating pressure on boiler gauge. Pressure must be between approximately 12 psi (cold water) and 25 psi at water temperature setting of high limit control, for boilers equipped with 30 psi relief valves. Boilers rated for a higher pressure and equipped with a matching relief valve may operate at a higher pressure, but no higher than 5 psi below the relief valve opening pressure.
- D. Check for and repair any leaks before placing system in service.

#### BEFORE FIRING BOILER, make these checks:

Before firing boiler, review the “Boiler Control and Display Features” section of this manual. Understanding the features and programming the applicable parameters is essential for setting up the boiler to operate properly on the heating system it is installed on.

1. System is full of water. Air is vented or purged.
2. Relief valve is installed in accordance with ASME Boiler and Pressure Vessel Code, Section IV. Valve opening is not closed or reduced in size.
3. Venting is installed according to instructions under “FLUE GAS VENTING REQUIREMENTS”.
4. All wiring is completed, following applicable wiring diagrams.
5. Using soap solution, check for gas leaks in all gas piping from meter to boiler gas supply pipe. DO NOT use open flame.

### II. BOILER CONTROL AND DISPLAY FEATURES (See Figure 23)

#### A. Boiler Operation Status:

“Mode Display” shows status of boiler operation (see table 3).

#### B. View and Changing Temperatures:

Setting boiler supply water temperature and water tank temperature (see table 4). Press “Select” button for viewing following different modes on “Mode Display”

1. While “c” is blinking, boiler supply water temperature for space heating may be set to desired temperature. The setting range is between 90° to 185°F.
2. While “d” is blinking, boiler supply water temperature for DHW may be set to desired temperature. The setting range is between 104° to 185°F.

3. While “t” is blinking, DHW tank temperature may be set to desired temperature (if tank is equipped with sensor). The setting range is between 104° to 185°F.

4. View actual boiler supply & return water temperature, domestic hot water tank temperature (if tank equipped with sensor), flue temperature and outside temperature (if outside sensor is used) on “Temperature Display” by selecting 1, 2, 3, 4, or 5 on “Mode Display”.
  - These numbers are steady on display and are not settable.
  - All sensor inputs to the control must be connected to a 12k ohm sensor.

#### C. Viewing and changing system setting:

A trained, experienced service technician or installer should perform following adjustments. See table 5 for details.

1. Space heating and DHW post pump time may be changed.
2. Space heating and DHW modes may be chosen.
3. Weather compensation slope and set point temperature may be changed (if outside sensor is used). (See Figure 24 for graph).
4. Read actual blower RPM
5. Adjust blower RPM for high and low input adjustment.
6. Read flame current in micro amp.
7. Run boiler on high, low or ignition input steady for 20 minutes for test purposes.

#### D. Display and push buttons:

1. **Reset** - Used to clear a Lock out error (indicated with an “A” in the “Mode Display”).
2. **Select** - Used to scroll through the modes in the “View and Changing Temperatures” and “Viewing and Changing System Setting” menus.
3. **Enter** - Used to store values that are changed in the “View and Changing Temperatures” and “Viewing and Changing System Setting” menus.
4. **Up** - Used to increase values in the “View and Changing Temperatures” and “Viewing and Changing System Setting” menus.
5. **Down** - Used to decrease values in the “View and Changing Temperatures” and “Viewing and Changing System Setting” menus.

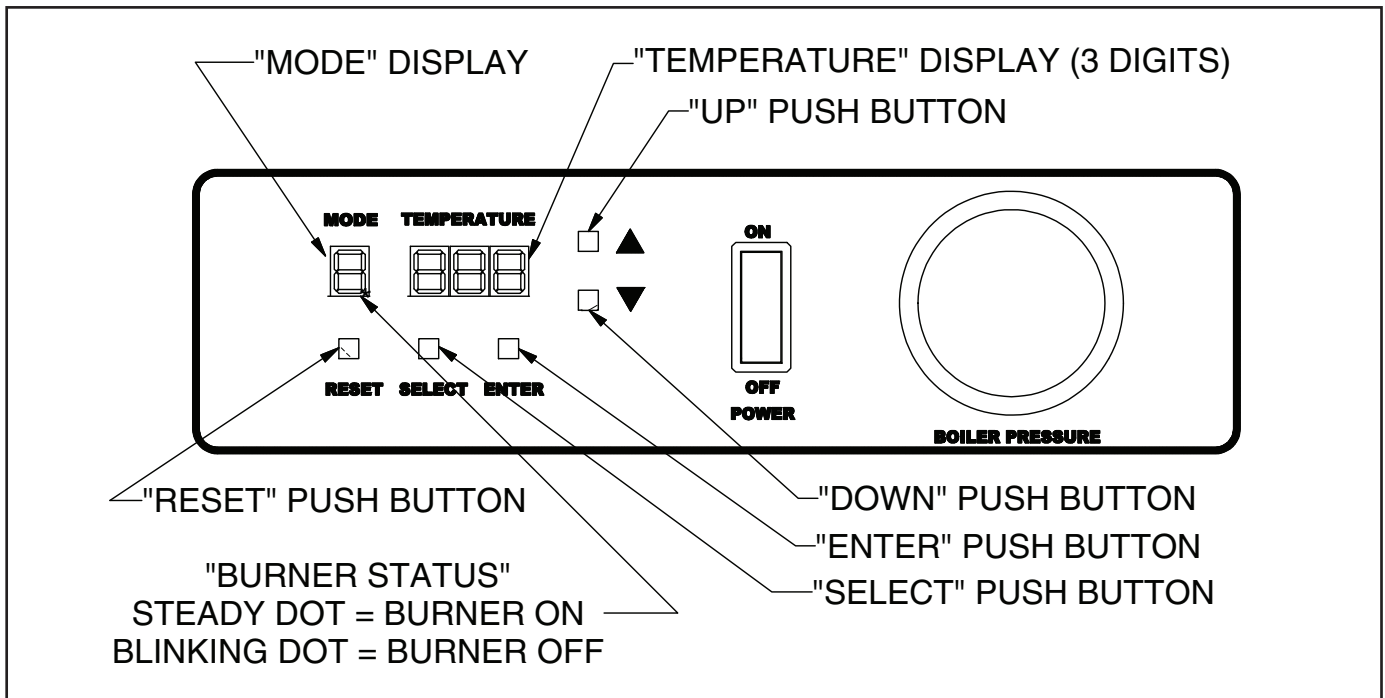

Figure 23. Display Board

**Table 3**  
**LYNX BOILER DISPLAY BOARD**  
*"Boiler Operation Status"*

| MODE DISPLAY | DESCRIPTION & TEMPERATURE DISPLAY  |
|--------------|--|
| 0            | Boiler is on stand-by mode.<br>Temperature display shows supply water Temp.  |
| c            | Space heating mode.<br>Temperature display shows supply water Temp.  |
| d            | Domestic hot water mode.<br>Temperature display shows supply water Temp.   |
| F            | Frost protection mode. **<br>Temperature display shows supply water Temp.  |
| R            | Lockout (Alarm) condition.<br>Temperature Display indicates the lockout code<br>Reset button must be pressed to resume normal operation. |
| E            | Error Condition. *<br>Temperature display indicates the error code.  |
| H            | Warning Condition. ***<br>Temperature display indicates the error code.  |

**NOTE:** Blinking dot on "Mode Display" indicates active heating control, burner off.  
 Steady dot indicates burner is on.

\*: Error must be corrected to resume boiler operation. Pressing the "Reset" button is not required.



\*\* : The boiler loop circulator is energized, if the boiler water temperature drops below 50°F.

\*\*\*: Error must be corrected to resume DHW operation. Space heating not affected. Pressing the "Reset" button is not required.

Table 4

**VIEWING AND CHANGING TEMPERATURES**

*Press “SELECT” button for viewing different modes on “MODE DISPLAY”*

| MODE DISPLAY  | DESCRIPTION & TEMPERATURE DISPLAY   |
|---|---|
| <br>blinking | Space heating supply water temperature could be changed by pressing “Up/Down” button. Settable from 90°F to 185°F (steps of 1 F). The default value is 176°F.<br>Press “Enter” button to store.<br>(see note 1) |
| <br>blinking | Domestic hot water supply temperature could be changed by pressing “Up/Down” button. Settable from 104°F to 185°F (steps of 1 F). The default value is 176°F.<br>Press “Enter” button to store.<br>(see note 2) |
| <br>blinking | Domestic hot water tank temperature could be changed by pressing “Up/Down” button. Settable from 104°F to 160°F (steps of 1 F). The default value is 140°F.<br>Press “Enter” button to store.<br>(see note 3)   |
| <b>1</b>  | Temperature display shows actual supply water temperature.  |
| <b>2</b>  | Temperature display shows actual return water temperature.  |
| <b>3</b>  | Temperature display shows actual DHW tank temperature.<br>(if the water tank is equipped with sensor).  |
| <b>4</b>  | Temperature display shows actual flue gas temperature.  |
| <b>5</b>  | Temperature display shows actual outside temperature.<br>(if outdoor sensor is used)  |

**NOTE:**

- 1- For space heating mode “0” (boilers not utilizing outdoor sensor))
- 2- For DHW mode “2” (storage tank with Aquastat)
- 3- For DHW mode “1” (storage tank with sensor)



**VIEWING AND CHANGING SYSTEM SETTING - Table 5**  
**“To change system setting or perform system test”**

The menu is accessed by pressing and holding “SELECT” and “ENTER” buttons for 10 seconds. To access different modes, press “SELECT” button To change system setting: Press “UP or DOWN” button, then press “ENTER”

**WARNING:** Only a trained, experienced service technician or installer should use this table.

| MODE DISPLAY               | DESCRIPTION   |
|----------------------------|---|
| P-c *                      | Changing space heating post pump time. Settable from 10 to 900 seconds. (steps of 10 seconds). The default value is 30 seconds.   |
| P-d *                      | Changing DHW post pump time. Settable from 1 to 255 seconds. (steps of 1 seconds). The default value is 15 seconds.   |
| c-t *                      | Changing space heating control mode<br>0: Thermostat only (default) - boiler without outdoor sensor<br>1: Outdoor sensor and Thermostat<br>2: Outdoor sensor only<br>3: Permanent heat demand (boiler circulator always on) |
| d-t *                      | Changing domestic hot water (DHW) mode<br>0: No DHW<br>1: Storage tank with sensor<br>2: Storage tank with thermostat (default value)   |
| b-t *                      | Changing DHW or space heating priority mode<br>0: DHW priority (no time limit)<br>1: Space heating priority (no time limit)<br>2: DHW priority for limited time (default)<br>3: Space heating priority for limited time     |
| b-P *                      | Changing priority limited time. Settable from 20 to 80 minutes. The default value is 30 minutes.  |
| A-t *                      | Boiler model selection, values are:<br>2 for model LX-90<br>3 for model LX-120<br>6 for model LX-150  |
| A-c *                      | Boiler model confirmation, values are:<br>2 for model LX-90<br>3 for model LX-120<br>6 for model LX-150   |
| n-P *                      | Natural or Propane gas selection<br>0: for natural gas (default)<br>1: for propane  |
| o-d *                      | Weather compensation supply water reference temperature (space heating mode 1 or 2). Settable from 16°F to 122°F (steps of 1 F). The default value is 86°F.   |
| o-S *                      | Changing compensation slope (space heating mode 1 or 2). Settable from 0.1 to 5.0 (steps of 0.1). The default value is 1.0.   |
| o-n *                      | Not Utilized  |
| o-t *                      | Changing weather compensation set point (space heating mode 2 only). Settable from 32°F to 122°F (steps of 1°F). The default value is 68°F.   |
| F **                       | Display shows blower RPM (mutiply reading by 10 for actual RPM)   |
| F-H *                      | Change blower RPM for high input (steps of 30 RPM, limit +/- 480 RPM).  |
| F-L *                      | Change blower RPM for low input (steps of 30 RPM, limit +/- 120 RPM).   |
| S **                       | Display shows flame current in micro amps   |
| S-0 *<br>S-L<br>S-I<br>S-H | System test – Display shows flame current<br>0: System test off<br>L: Steady low input (20 minutes)<br>I: Steady ignition input (20 minutes)<br>H: Steady high input (20 minutes)   |

**NOTE:** \*: Alternating \*\*: Steady

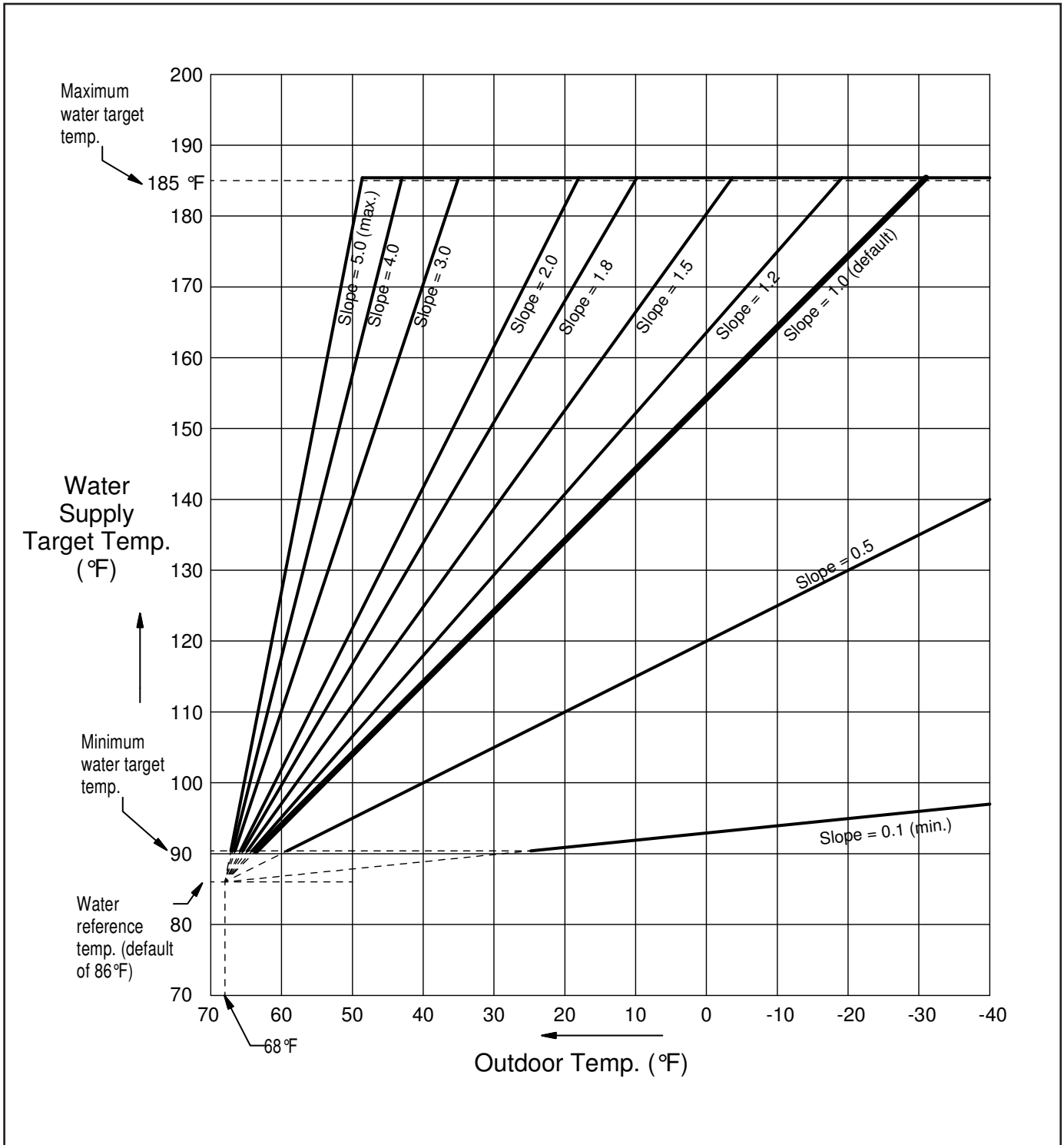

Figure 24. Space Heating mode with outside sensor water set point graph.

### III. INITIAL START

Safe lighting and other performance criteria were met when testing various gas manifold and control assemblies used on the Lynx boiler under the ANSI Z21.13 - latest edition.

#### Instructions

Follow the lighting instructions in this manual. These instructions are also attached to the boiler.

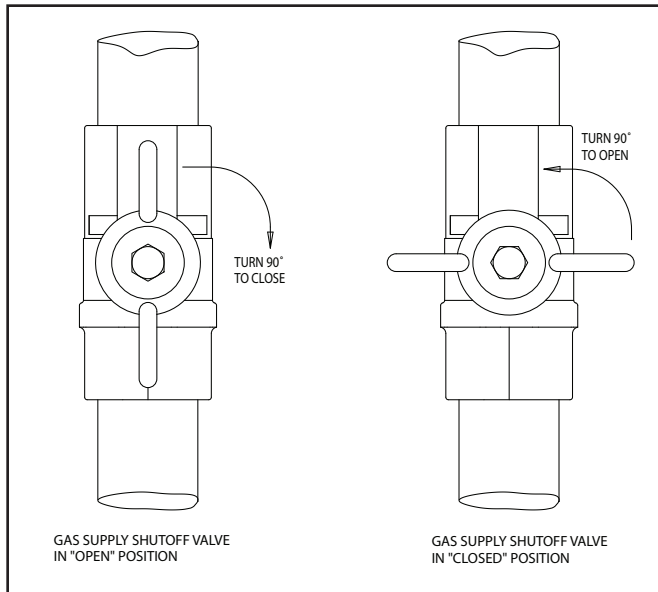

**Figure 25. Gas supply shutoff valve operation.**

#### SAFETY INFORMATION

For Your Safety Read Before Operating

**WARNING:** If you do not follow these instructions exactly, a fire or explosion may result causing property damage, personal injury or loss of life.

- A. **This appliance does not have a pilot. It is equipped with an ignition device which automatically lights the burner. DO NOT try to light the burner by hand.**
- B. **BEFORE OPERATING** smell all around the appliance area for gas. Be sure to smell next to the floor because some gas is heavier than air and will settle on the floor.

#### WHAT TO DO IF YOU SMELL GAS:

- DO NOT try to light any appliance.
- DO NOT touch any electric switch: DO NOT use any phone in your building.
- Immediately call you gas supplier from a neighbor's phone. Follow the gas supplier's instructions.
- If you cannot reach your gas supplier, call the fire department.

- C. Use only your hand to turn the gas supply shut-off valve. Never use tools. If the supply shut-off valve will not turn by hand, don't try to repair it, call a qualified service technician. Force or attempted repair may result in a fire or explosion.
- D. **DO NOT** use this appliance if any part has been under water. Immediately call a qualified service technician to inspect the appliance and to replace any part of the control system and any gas control which has been under water.

#### OPERATING INSTRUCTIONS

1. **STOP!** Read the safety information above.
2. Set the thermostat to lowest setting.
3. Turn off all electric power to the appliance.
4. This appliance is equipped with an ignition device which automatically lights the burner. **DO NOT** try to light the burner by hand.
5. Open the gas supply shut-off valve, by turning the handle to be parallel to the gas piping (See Figure 25).
6. Wait five (5) minutes (longer for propane) to clear out any gas, then smell for gas, including near the floor. If you then smell gas, **STOP!** Follow "B" in the safety information above on this page. If you don't smell gas, go to next step.
7. Turn on all electric power to the appliance.
8. Set thermostat to desired setting.  
If the appliance will not operate, follow the instructions "To Turn Off Gas to Appliance" and call your service technician or gas supplier.

#### TO TURN OFF GAS TO APPLIANCE

1. Set thermostat to lowest setting.
2. Turn off all electric power to the appliance if service is to be performed.
3. Close the gas supply shut off valve, by turning the handle to be perpendicular to the gas piping. (See Figure 25).

## LYNX BOILER SEQUENCE OF OPERATION

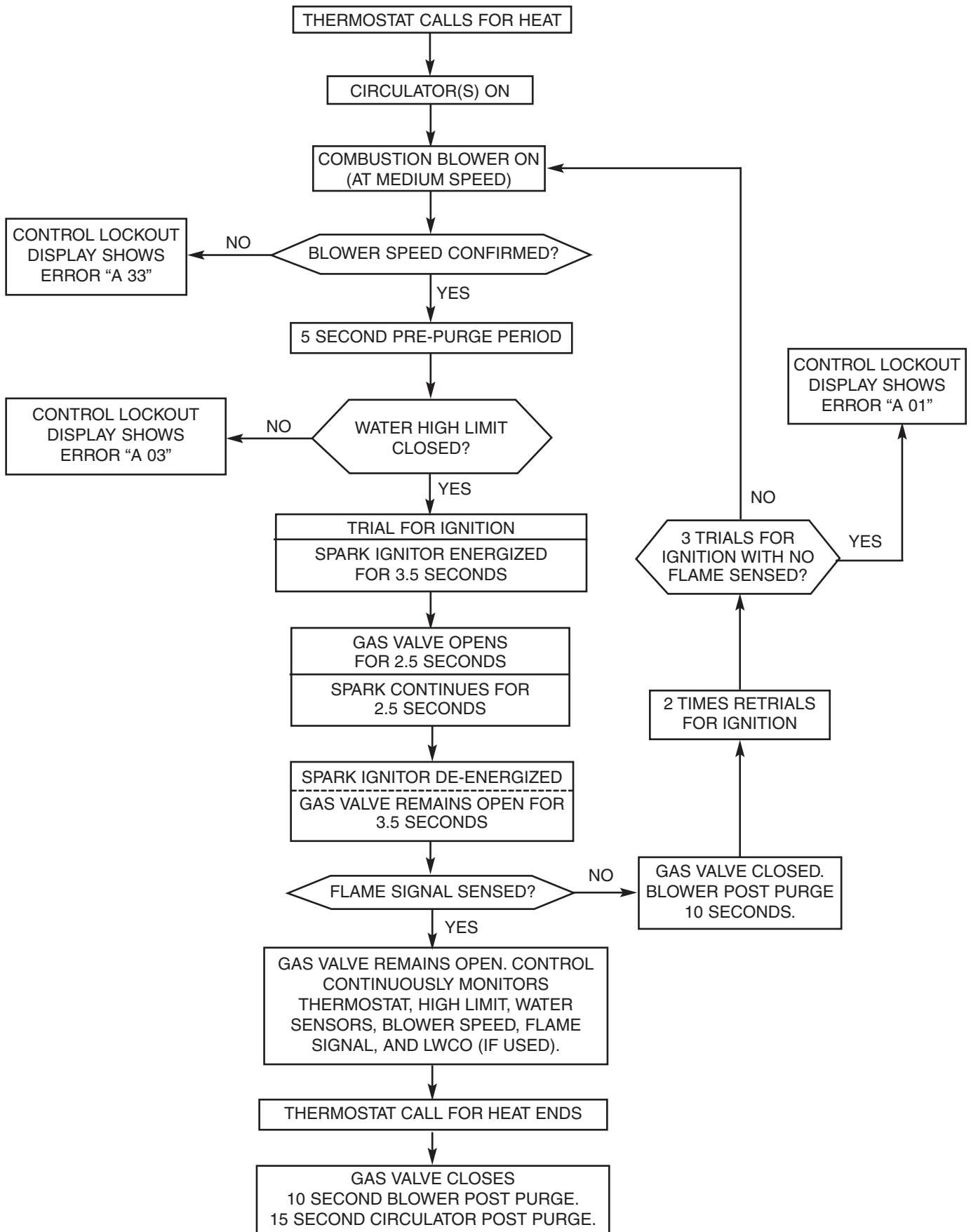

**IV. Check combustion and fuel input rate**

**Warning:** Only a trained and qualified service technician must do the adjustment to the input of the boiler.

- A. Remove the boiler jacket front panel by turning the black screws 1/4 turn to the open position. Lift off the panel.
- B. Start and run the boiler in the “System Test” mode in the “VIEWING AND CHANGING SYSTEM SETTING” menu. Refer to table 5 on page 33. Use the ▲ or ▼ push button to choose first the high (alternating S-H on mode display) and then the low (alternating S-L on mode display) firing rate.
- C. Check the fuel input rate on the gas meter (for natural gas boilers).

BTUH INPUT= cu.ft. metered in 3 minutes X heating value of the gas\* X 20

\*The higher heating value of the gas can vary for different localities. Consult the gas supplier for this value in BTU/cu.ft.

If the fuel input is not at the rate specified on page 2 at the high or low firing rate, then the blower speed should be adjusted to attain the specified input rate. This can be done by using the “Change blower RPM for high or low input” mode in the “VIEWING AND CHANGING SYSTEM SETTING” menu. Refer to Table 5 on page 33. Increasing the blower RPM will increase the fuel input rate, and decreasing the blower RPM will decrease the fuel input rate.

- D. Measure the CO and CO2 of the flue gas at high and low firing rate using a calibrated combustion test instrument. A flue sample port is provided in the vent pipe (See Figure 2 on page 3). The CO should not exceed 100 PPM at high input and 50 PPM at low input when the combustion is correct. The CO2 should be in the range listed in Table 6.

| Fuel        | Firing Rate | CO2%    |         |         |
|-------------|-------------|---------|---------|---------|
|             |             | Minimum | Nominal | Maximum |
| Natural Gas | High        | 9.2%    | 9.5%    | 9.8%    |
|             | Low         | 8.7%    | 9.0%    | 9.3%    |
| Propane     | High        | 10.7%   | 11.0%   | 11.3%   |
|             | Low         | 10.2%   | 10.5%   | 10.7%   |

**Table 6. Combustion values for natural gas and propane.**

- E. If the combustion (CO2 and CO measurement) at either high or low input rate is out of the range, shut down the boiler and contact Slant/Fin Tech. service department at 1-800-873-4346.

**Warning:** Failure to comply with the above mentioned requirement might result in property damage, personal injury or loss of life.

- F. Exit the “System Test” mode (Push “ENTER” button).

**V. SAFETY CHECK**

- A. **Check for gas leaks:**  
Using soap solution, check for gas leaks from meter to gas valve including all pipes and fittings and gas valve connections. Use liquid soap solution for all gas testing. DO NOT use open flame.
- B. **Thermostat Test:**  
Set thermostat setting to low enough to end call for heat. Gas valve should close and burner should stop firing. Blower and circulator pump should go into a post purge, then shut off.
- C. **Control Safety Shutdown test:**  
With the burner firing, disconnect the spark cable from the spark ignitor. Gas valve should close and burner should stop firing. The boiler will try for ignition three times after this, then should lock out with an “A 01” error shown on the display. Reconnect the spark cable to the spark ignitor, and press the “Reset” button to return to normal operation.

## VI. DIAGNOSTIC ERROR CODES

**WARNING:** Only a trained, experienced service technician should perform troubleshooting. Turn off all electric power to the boiler before service.

**A. LOCKOUT ERRORS:** Indicated by an "A" in the mode display. The reset button must be pressed to clear the error and retry operation. The temperature display shows the error code.

| ERROR CODE  | INDICATION  | REMEDY  |
|---|---|---|
| <b>01</b>   | Ignition Failure - 3 unsuccessful ignition attempts in a row. | Check for steady sparking at electrodes. If spark not steady - check spark gap to be .125", clean or replace spark ignitor, check power supply voltage and grounding. If spark is steady - check for proper gas supply pressure. Check combustion, if able to ignite, or replace gas valve. |
| <b>02</b>   | Flame Failure - 3 losses of flame signal during one demand.   | Check for proper combustion, at both max. and min. input firing rates. If combustion is within the range specified in Table 6 on page 36, clean or replace spark ignitor, check power supply voltage and grounding.   |
| <b>03</b>   | Water High Limit Open   | Check to see if the water outlet temperature reaches 203°F. If it does, replace the water outlet 12k ohm sensor. If it does not, replace the water high limit switch.   |
| <b>04, 05, 09, 10, 12, 13, 14, 15, 16, 18, 32</b> | Control Failure   | Replace control board. Make sure the proper boiler model selection and confirmation code is entered. See Table 5 on page 32.  |
| <b>19, 20</b>                                     | Flame Detected at Wrong Time                                  | If a flame is still observed after a call for heat is stopped, replace the gas valve. If the burner seems to be shutting down properly, replace the spark ignitor.  |
| <b>33</b>   | Fan Failure - RPM error                                       | Check wire harness connections going to the blower. Replace blower.   |

**B. BLOCKING ERRORS:** Indicated by an “E” in the mode display. Operation is automatically restored, once the condition returns to normal or is fixed. The temperature display shows the error code. Pressing the “Reset” button is not required.

| ERROR CODE                        | INDICATION                   | REMEDY   |
|-----------------------------------|------------------------------|--|
| <b>01</b>                         | Water Outlet Sensor Open     | Check wire harness connections going to the sensor.<br>Replace the sensor.   |
| <b>02</b>                         | Water Inlet Sensor Open      | Check wire harness connections going to the sensor.<br>Replace the sensor.   |
| <b>03</b>                         | Flue Gas Sensor Open         | Check wire harness connections going to the sensor.<br>Replace the sensor.   |
| <b>11</b>                         | Water Outlet Sensor Shorted  | Replace the sensor.  |
| <b>12</b>                         | Water Inlet Sensor Shorted   | Replace the sensor.  |
| <b>13</b>                         | Flue Gas Sensor Shorted      | Replace the sensor.  |
| <b>19, 42, 45,<br/>46, 47, 48</b> | Control Failure              | Replace control board. Make sure the proper boiler model selection and confirmation code is entered. See Table 5 on page 33.                                       |
| <b>20</b>                         | Flame Detected at Wrong Time | If a flame is still observed after a call for heat is stopped, replace the gas valve, If the burner seems to be shutting down properly, replace the spark ignitor. |
| <b>21</b>                         | Polarity Error               | Reverse the hot and neutral power supply wires.  |
| <b>22</b>                         | Frequency Error              | Check power supply frequency to be 60 hz, certain power supplies may not provide the proper frequency.   |
| <b>24</b>                         | Earth Connection Faulty      | Check grounding of control and boiler chassis.   |

*continued on page 40*

continued from page 39

| ERROR CODE | INDICATION                     | REMEDY  |
|------------|--------------------------------|---|
| 30         | Excess Flue Temperature        | Check flue gas temperature, at the maximum firing rate and high water temperature. If the flue gas temperature reaches 212°F, check the fuel input rate and combustion. Check the condition of the heat exchanger. If the flue gas temperature does not reach 212°F, replace the flue sensor. |
| 31         | Low Water Cutoff Error         | If a low water cutoff is installed, check the system water pressure and content. Check the condition of the LWCO. If no LWCO is installed, check the jumper is in place at the wiring terminal board. See Figure 16a on page 20.  |
| 32         | Excess Water Inlet Temperature | Check that the wire harnesses to the water inlet and outlet sensors are not reversed. The water inlet sensor harness should have a blue colored connector, the water outlet sensor harness should have a red colored connector. Check that the pumping flow direction is correct.             |
| 51         | Reset Button Error             | Try turning power supply off and on again. If error returns, replace the display board.   |
| 52         | Boiler Model Selection Error   | Check that the proper boiler model selection and confirmation code is entered in the display. See Table 5 on page 33.   |

**C. WARNING ERRORS:** Indicated by an “H” in the mode display. Operation of the space heating mode is not affected, and the warning is displayed intermittently. Operation of the DHW mode is automatically restored, once the condition is fixed. The temperature display shows the error code. Pressing the “reset” button is not required.

|    |  |  |
|----|--|--|
| 04 | Domestic Hot Water Tank Sensor Open    | If sensor is utilized, check wire harness connections going to the sensor, or replace the sensor. If no sensor is utilized, check the proper DHW mode is programmed. See Table 5 on page 33. |
| 14 | Domestic Hot Water Tank Sensor Shorted | If sensor is utilized, replace the sensor. If no sensor is utilized, check the proper DHW mode is programmed. See Table 5 on page 33.  |



## CARE AND MAINTENANCE

This section must be brought to the attention of the owner by the installer so that the owner can make the necessary arrangements with a qualified service agency for the periodic care and maintenance of the boiler. The installer must also inform the owner that the lack of proper care and maintenance of this boiler and any fuel burning equipment may result in a hazardous condition. Installer should discuss contents of the User's Information Manual (Publication LXA-UIM) with the owner.

A trained and qualified service technician should perform the inspection listed in these instructions before each heating season and at regular intervals.

### I. GENERAL MAINTENANCE

- A. Safety check, see page 38.
- B. Vent and air intake system inspection
  1. Check for obstruction, condensation, corrosion and physical damage.
  2. Check outside termination. Screen and louvers should be free of any debris and must be cleaned as required.
  3. Perform "Venting and Air Intake System Regular Inspection", see page 18.
- C. Piping
 

Check the following:

  1. Water piping and accessories for leaks. Slightest leaks should be corrected.
  2. System to be full of water and pressure to remain stable at correct setting on gauge.
  3. Air-control system. Noise and air binding in radiation should not occur.
  4. Low water cutoff for operation (see instruction furnished with unit).
- D. Boiler Room Air Supply
 

Check air vents for continuous positive supply of air as required. Air needs are greatest in cold weather if boiler installation is non-direct vent method. Air vents must open and free of obstruction.

**WARNING:** The flow of combustion and ventilating air to the boiler should not be obstructed.

## II. ANNUAL MAINTENANCE

It is recommended that the igniter be inspected annually and cleaned of all contaminants and if necessary replaced.

### III. INSPECTION DURING HEATING SEASON

- A. Check water pressure regularly and add water slowly to system when needed. If much water is added, venting may be necessary. Regular loss of water from boiler system may indicate either a system leak, or a faulty air control system, or a faulty automatic fill valve.
- B. Check venting system. See "Venting and Air Intake System Regular Inspection" on page 18.
- C. Check condensation drain trap to be full of water. Check for deterioration of the tubing. Check that the trap is not plugged.
- D. The combustion blower does not require or have provisions for lubrication.
- E. If required, lubricate the circulator as per the manufacturer's instruction.

### IV. CLEANING

- A. **Heat Exchanger:** In the unlikely event of flue passage or water passage blockage, service to remedy situation must be performed only by an authorized Slant/Fin representative.
- B. **Burner:** In the unlikely event of blockage or deterioration, service to remedy situation must be performed only by an authorized Slant/Fin representative.

### IF REPLACEMENT PARTS ARE NEEDED

When parts are needed, refer to boiler model and serial number shown on the boiler name/rating plate. Refer to publication number LX1-10PL replacement parts for part numbers. Whenever possible refer to the original order by number and date.

Control identification and replacement should not be attempted by unskilled personnel. Only, simple easily - identified controls and parts may be obtained locally. All other control and parts should be identified by and ordered from Slant./Fin. Relief/Safety valves must be ASME rated for the pressure and gross output of the boiler.

For replacement parts, heating contractors should contact their Slant/Fin boiler distributor.

## GENERAL TROUBLESHOOTING GUIDE FOR SERVICE PERSONNEL

**WARNING:** Only a trained, experienced service technician should perform troubleshooting.  
Turn off all electrical power to the boiler before servicing.

### A. BURNER FAILS TO OPERATE - NO HEAT

#### CAUSE

1. No power, display off, power switch off. Main electric switch open. Blown or defective line fuse.
2. Gas supply valve shut off.
3. Harnesses plug-in connectors are not securely connected.
4. Operational problem, detected by control.

#### REMEDY

1. Close switch. Check or replace fuse.
2. Open gas supply valve. Check gas pressure.
3. Check connectors on boiler control.
4. Error code on display can be correlated to specific problems and remedy. Refer to page 38-40 for error codes.

### B. NOT ENOUGH HEAT

1. Thermostat setting is too low.
2. Boiler water maintained at too low temperature.
3. Circulator not running.
4. Boiler water level too low.
5. Fuel input rate too low.

1. Set thermostat at higher setting.
2. Increase space heating set point temperature. Refer to Table 4 on page 32.
3. With thermostat calling for heat, check for power to circulator. If power is O.K. but circulator is not running, replace circulator.
4. Carefully snap open relief valve handle to determine if boiler is full of water, if not full of water, check for system leaks and check water pressure regulator. Repair any system leaks. Adjust or replace water pressure reducing valve.
5. Check the maximum fuel input firing rate. Refer to page 37 for the procedure.

### C. FUMES AND GAS ODORS

1. Leaks in gas piping or accessories.
2. Gas leaks in service line or meter connections.
3. Condensation trap is not full of water.
4. Venting system is physically damaged.
5. Over - firing or poor combustion.

1. Locate leaks and repair.
2. Close service supply valve - shut down boiler and notify utility.
3. Check and fill with water
4. Check carefully and repair. Also, see "Venting System Regular Inspection".
5. Check the maximum fuel input firing rate and combustion. Refer to page 37 for procedure.

NOTES:

Lined writing area with multiple horizontal lines for notes.



©Slant/Fin Corp. 2014.

---

**SLANT/FIN CORPORATION, Greenvale, N.Y. 11548 • Phone: (516) 484-2600**  
**FAX: (516) 484-5921 • Canada: Slant/Fin LTD/LTEE, Mississauga, Ontario**

**[www.slantfin.com](http://www.slantfin.com)**