



This manual must be left with owner and should be hung on or adjacent to the boiler for reference.

# HIGH EFFICIENCY FIRE TUBE CONDENSING GAS BOILER

## MODELS CHS-85 through CHS-399

### INSTALLATION AND OPERATING INSTRUCTIONS



#### TABLE OF CONTENTS

CONTENTS.....	PAGE
1.0 INTRODUCTION.....	3
2.0 SPECIFICATIONS .....	6
3.0 BOILER LOCATION.....	7
4.0 GENERAL VENTING .....	10
5.0 VENT/AIR-INLET TERMINATION CLEARANCES .....	25
6.0 CONDENSATE DRAIN .....	27
7.0 INSTALLING GAS PIPING.....	29
8.0 LIGHTING THE BOILER.....	32
9.0 GAS VALVE AND BURNER SET-UP .....	34
10.0 BOILER AND HEATING SYSTEM PIPING.....	38
11.0 FIELD WIRING .....	53
12.0 WIRING SCHEMATICS .....	58
13.0 INSTALLATION CHECKLIST.....	60
14.0 ANNUAL MAINTENANCE AND INSPECTION .....	61
15.0 TROUBLESHOOTING .....	63
16.0 PARTS LIST .....	86

#### IMPORTANT

READ ALL OF THE FOLLOWING WARNINGS AND STATEMENTS BEFORE READING THE INSTALLATION INSTRUCTIONS

#### **⚠ DANGER**

Danger Sign: Indicates a hazardous situation which, if not avoided, will result in serious injury or death.

#### **⚠ WARNING**

Warning Sign: Indicates a hazardous situation which, if not avoided, could result in serious injury or death.

#### **⚠ CAUTION**

Caution Sign plus Safety Alert Symbol: Indicates a hazardous situation which, if not avoided, could result in minor or moderate injury.

#### **CAUTION**

Caution Sign without Safety Alert Symbol: Indicates a hazardous situation which, if not avoided, could result in property damage.

#### **NOTICE**

Notice Sign: Indicates a hazardous situation which, if not avoided, could result in property damage.

#### **⚠ WARNING**

This Boiler must be installed by a licensed and trained Heating Technician or the **Warranty is Void**. Failure to properly install this unit may result in property damage, serious injury to occupants, or possibly death.

Heating Contractor

Address

Phone Number

Boiler Model Number

Boiler Serial Number

Installation Date

**Read Before Proceeding**

If you do not follow these instructions exactly, a fire or explosion may result causing property damage, serious injury or death.

**FOR YOUR SAFETY, READ BEFORE OPERATING**

- A) This boiler does not have a pilot. It is equipped with an ignition device which automatically lights the burner. Do not try to light the burner by hand.
- B) BEFORE OPERATING smell all around the boiler area for gas. Be sure to smell next to the floor because some gas is heavier than air and will settle on the floor.  
WHAT TO DO IF YOU SMELL GAS:
  - Do not try to light any boiler.
  - Do not touch any electric switch.
  - Do not use any phone in your building.
  - Immediately call your gas supplier from a neighbor's phone. Follow the gas supplier's instructions.
  - If you cannot reach your gas supplier, call the fire department.
- C) Use only your hand to turn the gas "shutoff" valve. Never use tools. If the handle will not turn by hand, don't try to repair it, call a qualified service technician. Force or attempted repair may result in a fire or explosion.
- D) Do not use this boiler if any part has been under water. Immediately call a qualified service technician to inspect the boiler and to replace any part of the control system and any gas control which has been under water.

**OPERATING INSTRUCTIONS**

1. STOP! Read the safety information above very carefully.
2. Set the thermostat to lowest setting. Turn off all electric power to the boiler.
3. This boiler does not have a pilot. It is equipped with an ignition device which automatically lights the burner. Do not try to light the burner by hand.
4. Turn the manual gas valve to the OFF position. Remove front access panel.
5. Wait five (5) minutes to clear out any gas. Then smell for gas, including near the floor. If you smell gas, STOP! Follow "B" in the safety information above. If you don't smell gas, go to the next step.
6. Turn the manual gas valve ON. Wait an additional five (5) minutes smelling for gas.
7. Replace the front access panel.
8. Set thermostat to highest setting. Turn on all electric power to the boiler.
9. Ignition sequence is automatic. Combustion will occur after a brief fan purge.
10. If ignition does not occur, follow the instructions "To Turn Off Gas To Boiler" and call your service technician or gas supplier.

**TO TURN OFF GAS TO THE BOILER**

1. STOP! Read the safety information above very carefully.
2. Turn off all electric power to the boiler.
3. Turn the manual gas valve to the OFF position.



**Crystalline Silica** - Certain components confined in the combustion chamber may contain this potential carcinogen. Improper installation, adjustment, alteration, service or maintenance can cause property damage, serious injury (exposure to hazardous materials) or death. Refer to Section 14.0 for information on handling instructions and recommended personal protective equipment. Installation and service must be performed by a qualified installer, service agency or the gas supplier (who must read and follow the supplied instructions before installing, servicing, or removing this boiler. This boiler contains materials that have been identified as carcinogenic, or possibly carcinogenic, to humans).



**Void Warranty** - This Boiler must have water flowing through it whenever the burner is on or it will damage the unit and void the warranty. Failure to follow these instructions may result in serious injury or death.

## 1.0 INTRODUCTION

### General Installation Requirements

The installation of your Slant/Fin CHS gas boiler must conform to the requirements of this manual, your local authority, and the National Fuel Gas Code ANSI Z223.1 and or CAN/CGA B149 Installation Codes. Where required by the Authority, the installation must conform to the standard for “Controls and Safety Devices for Automatically Fired Boilers ANSI/ASME CSD-1.

This document pertains to the correct installation and operation of Slant/Fin boiler model CHS. The instructions detailed in this document supersede any and all previous instructions provided by Slant/Fin, written or otherwise. Each unit is provided with the following:

1. Installation and Operating Instructions,
2. Appendix A – Controller and Display Instructions,
3. CHS User Manual, and
4. Natural Gas to LP Conversion Kit\*

\* The conversion kit is required to convert the boiler so it will safely operate with Propane Gas.

#### **DANGER**

Read and understand this entire document prior to proceeding with the installation of the CHS boiler. Failure to follow the instructions outlined in this document will result in property damage, serious injury or death.

#### **IMPORTANT**

**Energy Saving Feature** - This boiler is equipped with a feature that saves energy by reducing the boiler water temperature as the heating load decreases. This feature is equipped with an override which is provided primarily to permit the use of an external energy management system that serves the same function. **THIS OVERRIDE MUST NOT BE USED UNLESS AT LEAST ONE OF THE FOLLOWING CONDITIONS IS TRUE:**

- An external energy management system is installed that reduces the boiler water temperature as the heating load decreases.
- This boiler is not used for any space heating.
- This boiler is part of a modular or multiple boiler system having a total input of 300,000 BTU/hr or greater.
- This boiler is equipped with a tankless coil.

### User Responsibilities

This boiler must be installed and serviced by a qualified installer or service technician. This boiler must be serviced and inspected annually when operating in normal residential applications. Demanding applications or extreme conditions (i.e. commercial) may require more frequent service and inspection. As the User/Owner of this equipment, you are responsible for ensuring the maintenance is performed at the required intervals (see Section 14 – Annual Maintenance and Inspection).

#### **WARNING**

Failure to have the boiler properly serviced and inspected on a regular basis by a qualified service technician may result in property damage, serious injury or death.

#### **WARNING**

Failure to keep the Vent and Combustion Air Intake clear of ice, snow, and other debris may result in property damage, serious injury, or death.

### Installer Responsibilities

As the installing technician it is your responsibility to ensure the installation is performed in accordance with this instruction manual as well as any applicable local or National installation codes. It is also your responsibility to inform the User/Owner of their obligation with respect to the above description under “User Responsibilities”. Failure to follow this warning could result in fire, serious injury, or death.



CHS boilers are factory set to operate with Natural Gas; **BEFORE OPERATING WITH PROPANE**, the boiler must be converted using the appropriate *Natural Gas to LP Conversion Kit*; see below. Failure to properly convert the unit to safely operate with Propane will cause dangerous burner operation, resulting in property damage, serious injury or death.

### **ATTENTION: LIQUEFIED PETROLEUM (LP) PROPANE**

Liquefied Petroleum (LP) propane gas is heavier than air; therefore, it is imperative that your boiler is not installed in a pit or similar location that will permit heavier than air gas to collect. Local Codes may require boilers fueled with LP gas be provided with an approved means of removing unburned gases from the room. Check your local codes for this requirement.

#### **Natural Gas to LP Conversion Kit**

<b><u>Model</u></b>	<b><u>Kit Part Number</u></b>	<b><u>LP-Orifice</u></b>
CHS-85	81 8124 000	415 (4.15 mm)
CHS-110	81 8124 000	52 (5.2 mm)
CHS-154	81 8278 000	See Note 1
CHS-201	81 8292 000	See Note 2
CHS-285	80 8293 000	5.2 mm
CHS 399 (pre s/n 84200) <sup>3</sup>	81 8125 000	74 (7.4 mm)
CHS 340-399 (post s/n 95974) <sup>4</sup>	81 8279 000	6.75 mm

#### **Notes:**

<sup>1</sup> The CHS-154 is converted to Propane using a replacement LP-Venturi Insert (81 8245 000), not an LP-Orifice. Follow the Natural Gas to LP Conversion Instructions provided with kit number 81 8278 000.

<sup>2</sup> The CHS-201 is converted to Propane using a replacement LP-Venturi Insert (81 8294 000), not an LP-Orifice. Follow the Natural Gas to LP Conversion Instructions provided with kit number 81 8292 000.

<sup>3</sup> CHS-399's, with a serial number of 84199 and lower are converted to Propane using kit number 81- 8125 000.

<sup>4</sup> CHS-399's with a serial number greater than 95974, and all CHS-340's, are converted to Propane using kit number 81- 8279 000.

### **Boiler Vent / Air-Inlet Piping**



The CHS boiler is certified as a "Category IV" boiler, and requires a "Special Venting System" designed for pressurized venting. The exhaust gases must be piped directly to the outdoors using the vent materials and rules outlined in these instructions. Failure to follow these instructions will result in serious injury or death.

**IN THE STATE OF MASSACHUSETTS ONLY**

- (a) For all horizontally vented gas fueled equipment installed in every dwelling, building or structure used in whole or in part for residential purposes, including those owned and operated by the Commonwealth and where the side wall exhaust vent termination is less than seven (7) feet above finished grade in the area of the venting, including but not limited to decks and porches, the following requirements shall be satisfied:
1. **INSTALLATION OF CARBON MONOXIDE DETECTORS** At the time of installation of the side wall horizontal vented gas fueled equipment, the installing plumber or gas fitter shall observe that a hard wired carbon monoxide detector with an alarm and battery back-up is installed on the floor level where the gas equipment is to be installed and on each additional level of the dwelling, building or structure served by the equipment. It shall be the responsibility of the property owner to secure the services of qualified licensed professionals for the installation of hard wired carbon monoxide detectors.
    - a. In the event that the side wall horizontally vented gas fueled equipment is installed in a crawl space or an attic, the hard wired carbon monoxide detector with alarm and battery back-up may be installed on the next adjacent floor level.
    - b. In the event that the requirements of this subdivision can not be met at the time of completion of installation, the owner shall have a period of 30 days to comply with the above requirements; provided, however, that during said 30 day period a battery operated carbon monoxide detector with an alarm shall be installed.
  2. **APPROVED CARBON MONOXIDE DETECTORS** Each carbon monoxide detector as required in accordance with the above provisions shall comply with NFPA 720 and be ANSI/UL 2034 listed and IAS certified.
  3. **SIGNAGE** A metal or plastic identification plate shall be permanently mounted to the exterior of the building at a minimum height of eight (8) feet above grade directly in line with the exhaust vent terminal for the horizontally vented gas fueled heating boiler or equipment. The sign shall read, in print size no less than one-half (1/2) inch in size, "***GAS VENT DIRECTLY BELOW. KEEP CLEAR OF ALL OBSTRUCTIONS***" (*plate included with boiler*).
  4. **INSPECTION** The state or local gas inspector of the side wall horizontally vented gas fueled equipment shall not approve the installation unless, upon inspection, the inspector observes carbon monoxide detectors and signage installed in accordance with the provisions of 248 CMR 5.08(2)(a)1 through 4.
- (b) **EXEMPTIONS:** The following equipment is exempt from 248 CMR 5.08(2)(a)1 through 4:
1. The equipment listed in Chapter 10 entitled "Equipment Not Required To Be Vented" in the most current edition of NFPA 54 as adopted by the Board; and
  2. Product Approved side wall horizontally vented gas fueled equipment installed in a room or structure separate from the dwelling, building or structure used in whole or in part for residential purposes.
- (c) **MANUFACTURER REQUIREMENTS – GAS EQUIPMENT VENTING SYSTEM PROVIDED:** When the manufacturer of Product Approved side wall horizontally vented gas equipment provides a venting system design or venting system components with the equipment, the instructions provided by the manufacturer for installation of the equipment and the venting system shall include:
1. Detailed instructions for installation of the venting system design or the venting system components; and
  2. A complete parts list for the venting system design or venting system.
- (d) **MANUFACTURER REQUIREMENTS – GAS EQUIPMENT VENTING SYSTEM NOT PROVIDED:** When the manufacturer of a Product Approved side wall horizontally vented gas fueled equipment does not provide the parts for venting the flue gases, but identifies "special venting systems", the following requirements shall be satisfied by the manufacturer:
1. The referenced "special venting system" instructions shall be included with the appliance or equipment installation instructions; and
  2. The "special venting system" shall be Product Approved by the Board, and the instructions for that system shall include a parts list and detailed installation instructions.
- (e) A copy of all installation instructions for all Product Approved side wall horizontally vented gas fueled equipment, all venting instructions, all parts list for venting instructions, and/or all venting design instructions shall remain with the appliance or equipment at the completion of the installation.

**2.0 SPECIFICATIONS**

**Table 2-1 CHS Specifications**

DESCRIPTION	CHS-85	CHS-110	CHS-154	CHS-201	CHS-285	CHS-340	CHS-399
CSA Input Modulation <sup>1</sup> [MBH]	17-85	21.6-108	15.4-154	20-200	28.5-285	39.9-340	39.9-399
DOE Heating Capacity <sup>1,2</sup> [MBH]	78	99	141	185	263	324	380
Net I=B=R Rating <sup>1,2</sup> [MBH]	68	86	122	160	228	282	330
DOE AFUE <sup>2</sup> [%]	95					95.4	
Water Connections – NPT [in.]	1 (Male)			1-1/4 (Male)		1-1/2 (Male)	
Gas Connection - NPT, in.	1/2 (Male)					3/4 (Male)	
Vent/Air-inlet Pipe Diameter [in.] <sup>3</sup>	2 or 3		3			4	
Cabinet Height [in.]	33-3/8					36-5/8	
Cabinet Width [in.]	19-3/4				21-1/4	25-1/4	
Cabinet Depth [in.]	14-3/4		18-7/8			20	
Approx. Boiler Weight with Water [lbs]	110		160	180		250	
Approx. Boiler Water Content [Gallons]	3.2		3.9	4.9		7.1	6.4
Electrical Rating	120V/1Ph/60Hz/less than12A						
<b>Notes:</b>							
<sup>1</sup> Listed Input and Output ratings are at minimum vent lengths at an altitude of 0-2000ft. Numbers will be lower with longer venting and/or altitudes greater than 2000ft.							
<sup>2</sup> Ratings based on standard test procedures prescribed by the U.S. Department of Energy; certified by AHRI. Efficiency listed for models CHS-340 & CHS-399 represents Thermal Efficiency (AFUE is not applicable).							
<sup>3</sup> The CHS requires a special venting system, use only vent materials and methods detailed in these instructions.							
<sup>4</sup> When operating with Propane models CHS-85 and CHS-110 have min/max Input Modulation rates of 17.6/88 and 22.6/113 MBH respectfully.							



Wall mounting of unit requires two people to lift the boiler into place. Failure to follow these instructions may result in property damage or personal injury.

**High Altitude Operation**

The CHS boiler is designed to operate at its maximum listed capacity in installations located at 0-2000ft above Sea Level. Since the density of air decreases as elevation increases, maximum specified capacity should be de-rated for elevations above 2000 ft [610 m] in accordance with Table 2-2.

**Table 2-2 De-rate % for High Altitudes**

Elevations	2001 ft [610 m]	3000 ft [914 m]	4000 ft [1219 m]	4500 ft [1372 m]	5000 ft [1524 m]
In Canada <sup>1</sup>	de-rate by 10%	de-rate by 10%	de-rate by 10%	de-rate by 10%	de-rate % may vary
In USA <sup>2</sup>	-	de-rate by 12%	de-rate by 16%	de-rate by 18%	de-rate by 20%
<b>Notes:</b>					
<sup>1</sup> Canada: Altitudes between 2000-4500 ft [610-1372 m], de-rate by 10%. Consult local authorities for de-rating capacities for altitudes above 4500 ft [1372 m].					
<sup>2</sup> USA: De-rate capacity by 4% for every 1000 ft [305 m], if altitude is above 2000 ft [610 m]. For altitudes higher than 5000 ft, continue de-rating by 4% for every 1000 ft. E.g. for altitude = 15,000 ft; de-rate = 60% (4% x 15).					



**Combustion** – At elevations above 2000 feet, the combustion of the boiler must be checked with a calibrated combustion analyzer to ensure safe and reliable operation. **It is the Installers responsibility to check the combustion and to adjust the combustion in accordance with Section 9.0.** Failure to follow these instructions may result in property damage, serious injury, or death.

### 3.0 BOILER LOCATION

In all cases, the CHS boiler must be installed indoors in a dry location where the ambient temperature must be maintained above freezing and below 100°F [38°C]. All boiler components must be protected from dripping, spraying water, or rain during operation and servicing. Consider the proximity of system piping, gas and electrical supply, condensate disposal drain, and proximity to vent termination when determining the best boiler location.

**WARNING**

Water or flood damaged components must be replaced immediately with new factory-approved components as failure to do so may result in fire, serious injury, or death.

#### Boiler Area Ventilation Air Openings

**Direct Vent** – If boiler area clearances are less than the recommended clearances specified in Table 3-1, the boiler area must be ventilated (**Exception:** if the boiler area/room has a volume of 150 ft<sup>3</sup> or greater, ventilation of the boiler room is not required). Each ventilation air opening must meet the minimum requirements of 1 in<sup>2</sup> per 1000 Btu/hr, but not less than 100 in<sup>2</sup>. The lower ventilation opening must be located within 6” of the floor while the upper opening must be located 6” from the top of the space.

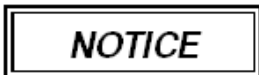
**NOTICE**

If the "Boiler Area" does not meet the recommended clearances listed in Table 3-1, and if the boiler area has a volume less than 150 ft<sup>3</sup>, it is considered a Closet or Alcove. PVC vent pipe and fittings shall not be used within the closet or alcove; only approved CPVC, Polypropylene or Stainless Steel vent pipe and fittings can be used. See Table 4-4 for a list of approved materials. Under all circumstances, the minimum clearances listed in Table 3-1 must be provided.

**Indoor Combustion Air** – When using Indoor Combustion Air in lieu of Direct Vent air-inlet piping, provisions for combustion and ventilation air, in accordance with section “Air for Combustion and Ventilation,” of the *National Fuel Gas Code, ANSI Z223.1/NFPA 54* (U.S.), or Clause 8.2, 8.3 or 8.4 of *Natural Gas and Propane Installation Code, CAN/CSA B149.1* (Canada), or applicable provisions of the local building codes, must be adhered to.

#### Closet Installations

For closet installations it is necessary to provide two ventilation air openings as shown in Figure 3-1, each providing a minimum area equal to 1 in<sup>2</sup> per 1000 Btu/hr, but not less than 100 in<sup>2</sup> and within 6” of the top and bottom of the closet door. See Table 3-1 for minimum clearances.

#### Alcove Installations

Alcove installations have the same minimum clearances as closet installations, except the front must be completely open to the room at a distance no greater than 18” [457 mm] from the front of the boiler and the room is at least three (3) times the size of the alcove. Provided these conditions are met, the boiler requires no extra ventilation air openings to the space. See Table 3-1 for minimum clearances.

#### Residential Garage Installations

When installed in a residential garage, mount the boiler a minimum of 18” [457 mm] above the floor. Locate or protect the boiler so it cannot be damaged by a moving vehicle. Check with your local authorities for other possible regulations pertaining to the installation of a boiler in a garage.

#### Wall Mounting Installations

The CHS is provided with integrated wall mounting brackets. Refer to Figure 3-2 for instructions and illustrations on wall mounting.

Table 3-1 Minimum Clearances for Installation and Service

Model No.	Clearances	Dimensions - inches [mm]					
		Front	Top	Sides	Back	Bottom	Flue Pipe
CHS 85-399	Minimum	24 [610] <sup>1</sup>	12 [305]	4 [102]	0	16 [407]	1 [25]
	Recommended	36 [914]	24 [610]	12 [305]	0	24 [610]	1 [25]

**Notes:**

<sup>1</sup> 6" if surface is removable allowing a minimum of 24" [610 mm] clearance (i.e. closet installation). See Ventilation Air Opening dimensions in Figure 3-1.



Closet/alcove installations in US and Canada require approved **CPVC, Polypropylene or Stainless Steel** vent and air-inlet pipe and fittings (see Table 4-4); PVC is not permitted. Failure to follow these instructions may result in damage or serious injury.

Figure 3-1 Closet Installation, Minimum Clearances (Model CHS 85-110 Illustrated)

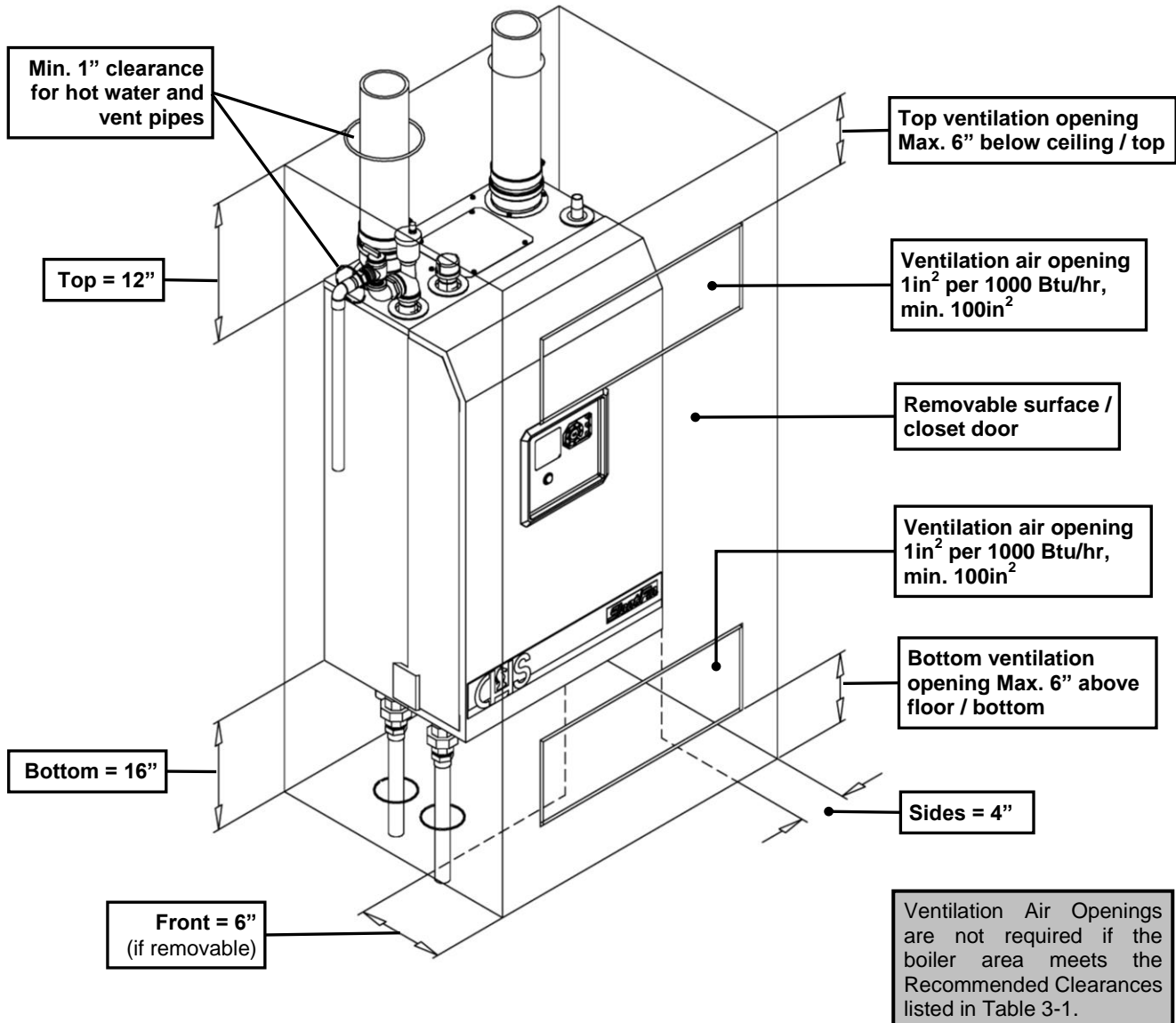

**NOTICE** Boiler Exhaust Vent and Air-inlet connection location varies between models; reference the Figures 4-2, (a) through (h), for correct location.



Figure 3-2 Wall Mounting Instructions

- 1 While leaving the **Upper bracket (A)** intact, remove the **Wall-mount bracket (B)** attached to the bottom-back of the appliance. Save the mounting hardware for Step 4.
- 2 Secure the **Wall-mount bracket (B)**, removed from the bottom of the boiler in Step 1, to a solid wall using field supplied lag screws (anchors when mounting to a concrete wall) that are adequate to support the weight of the appliance (refer to Table 2-1 Specifications). Ensure the Wall-mount bracket is mounted level and flush to the wall with mounting holes on the bottom, flange pointed upward and angled away from the wall.
- 3 Mount the appliance to the wall by aligning the **Upper bracket (A)** with the **Wall-mount bracket (B)**. Slide the Upper bracket down over the wall mount bracket until it hooks.
- 4 Once the appliance is resting securely on the Upper bracket, secure the **Bottom bracket (C)** to the underside of the appliance using the mounting hardware removed in Step 1; then, anchor the bottom bracket to the wall as shown using field supplied hardware.

**WARNING**

Failure to follow instructions may result in fire, serious injury, or death.

**CAUTION**

This unit requires two people to lift it or damage and injury may result.

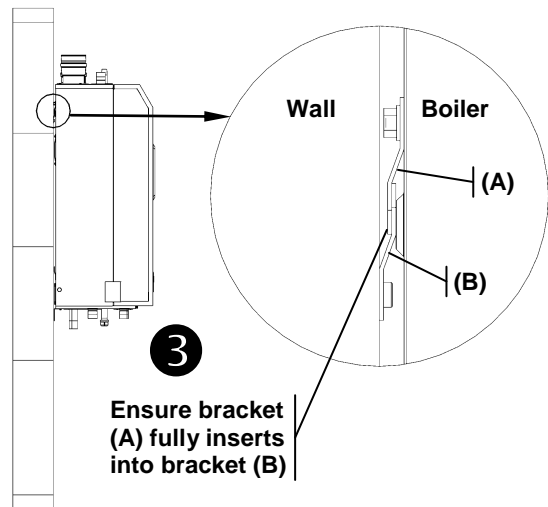
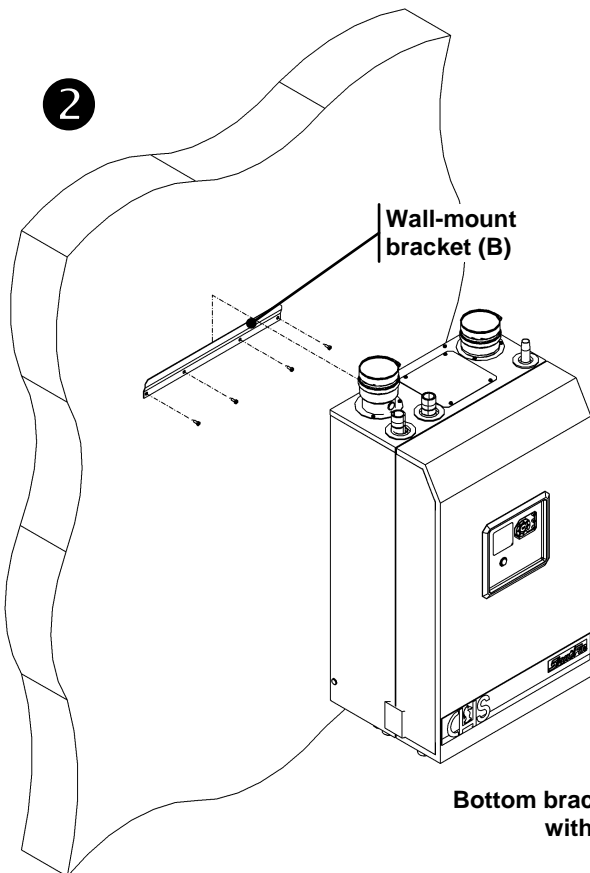
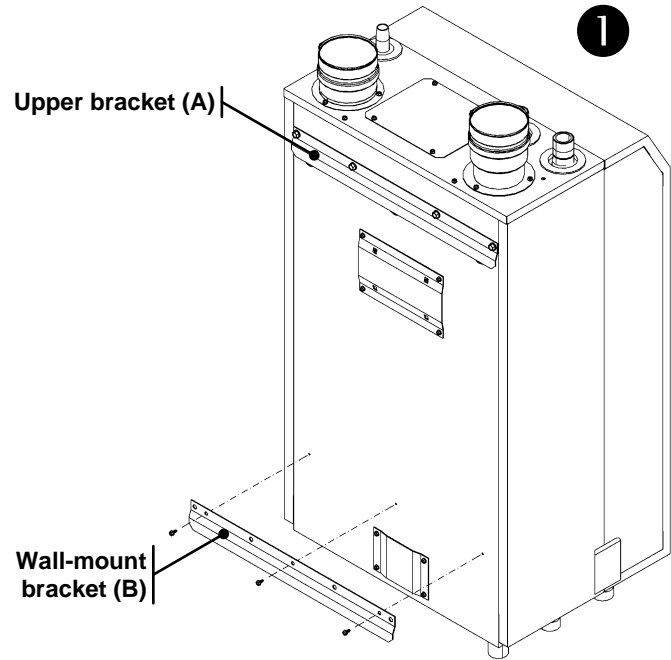

Ensure bracket (A) fully inserts into bracket (B)

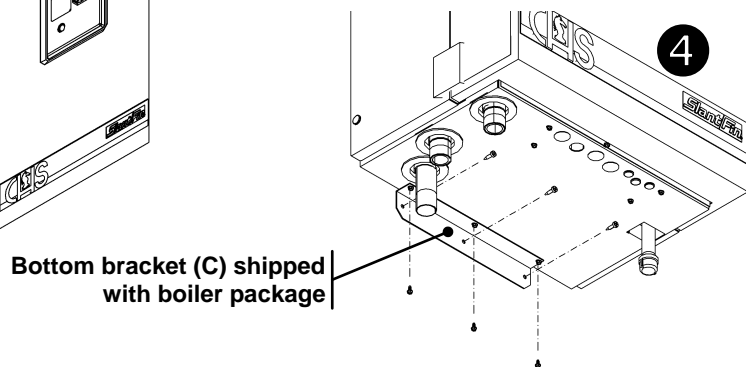

#### 4.0 GENERAL VENTING

The CHS boiler is certified as a “Category IV” boiler requiring a “Special Venting System” designed for pressurized venting. The Exhaust Vent must be piped to the outdoors, using the vent materials and rules outlined in this section. Under no conditions may this unit vent gases into a masonry chimney, unless it is vacant, and utilizes the approved venting material and rules described in this section.



Vent and Air-inlet are to be piped separately. The CHS cannot share a common vent or air-inlet with multiple boilers. Failure to comply will result in serious injury or death.

#### Removing an Existing Boiler from Common Venting System



Do not install the CHS into a common venting system with any other boiler. Failure to comply with this warning will cause flue gas spillage and leech carbon monoxide emissions into the surrounding air resulting in serious injury or death.



When an existing boiler is removed from a common venting system, the common venting system is likely to be too large for proper venting of the remaining boilers connected to it. Instructions have been provided on how to remove the existing boiler and how to resize the remaining venting system. Failure to follow these instructions may result in property damage, serious injury or death.

Upon removal of an existing boiler, the following steps shall be followed for each boiler remaining in the common venting system; prior to commencing this procedure, shutdown all boilers remaining in the common venting system.

#### Steps to Removing an Existing Boiler:

1. Seal any unused openings in the common venting system.
2. Visually inspect the venting system for proper size and horizontal pitch. Verify that there is no blockage, restriction, leakage, corrosion or other deficiencies which could cause an unsafe condition.
3. Insofar as is practical, close fireplace dampers, all building doors and windows and all doors between the space in which the boilers remaining connected to the common venting system are located and other spaces of the building. Turn on clothes dryers and any boiler not connected to the common venting system. Turn on any exhaust fans, such as range hoods and bathroom exhausts, so they will operate at maximum speed. Do not operate a summer exhaust fan.
4. Place in operation the boiler being inspected. Follow the applicable lighting instructions. Adjust thermostat so boiler will operate continuously.
5. Test for spillage at the draft hood relief opening after 5 minutes of main burner operation. Use the flame of a match or candle, or smoke from a cigarette, cigar or pipe.
6. After it has been determined that each boiler remaining connected to the common venting system properly vents when tested as outlined above, return doors, windows, exhaust fans, fireplace dampers and any other gas burning boiler to their previous condition of use.
7. Any improper operation of the common venting system should be corrected so the installation conforms to the National Fuel Gas Code, ANSI Z223.1/NFPA 54 and/or CAN/CSA B149.1, Natural Gas and Propane Installation Code. When resizing any portion of the common venting system, the common venting system should be resized to approach the minimum size as determined using the appropriate tables in Part 11 of the National Fuel Gas Code, ANSI Z223.1/NFPA 54 and/or CAN/CSA B149.1, Natural Gas and Propane Installation Code.

**Direct Vent Installation**

When installed as a Direct Vent boiler the combustion air-inlet must also be piped directly to the outdoors using the methods described in this section and in accordance with the National Fuel Gas Code, ANSI Z223.1 (U.S.) or CSA B149.1 (Canada) and local requirements.

**Installation Using Indoor Combustion Air**

When the installation uses Indoor Combustion Air (i.e. piping is not directly connecting the appliance air-inlet fitting to the outdoors), provisions for combustion and ventilation air, in accordance with section “Air for Combustion and Ventilation,” of the *National Fuel Gas Code, ANSI Z223.1/NFPA 54* (U.S.), or Clause 8.2, 8.3 or 8.4 of *Natural Gas and Propane Installation Code, CAN/CSA B149.1* (Canada), or applicable provisions of the local building codes, must be adhered to.

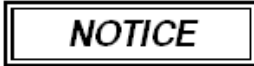

The boiler shall be located so as not to interfere with proper circulation of combustion, ventilation, and dilution air.



Make up air requirements for the operation of exhaust fans, kitchen ventilation systems, clothes dryers, and fireplaces shall be considered in determining the adequacy of a space to provide combustion air requirements. Failure to ensure adequate make up air to all appliances may result in personal injury or death.

**Combustion Air-inlet Contamination**

Be careful not to locate the air-inlet termination in an area where contaminants can be drawn in and used for combustion. Combustion air containing dust, debris or air-borne contaminants will drastically increase the required maintenance and may cause a corrosive reaction in the Heat Exchanger which could result in premature failure, fire, serious injury, or death. See Table 4-1 for a list of areas to avoid when terminating air-inlet piping:

**Table 4-1 Corrosive Products and Contaminant Sources**

Products to Avoid	Contaminated Sources to Avoid
Antistatic fabric softeners, bleaches, detergents, cleaners	Laundry facilities
Perchloroethylene (PCE), hydrocarbon based cleaners	Dry cleaning facilities
Chemical fertilizer, herbicides/pesticides, dust, methane gas	Farms or areas with livestock and manure
Paint or varnish removers, cements or glues, sawdust	Wood working or furniture refinishing shops
Water chlorination chemicals (chloride, fluoride)	Swimming pools, hot tubs
Solvents, cutting oils, fiberglass, cleaning solvents	Auto body or metal working shops
Refrigerant charge with CFC or HCFC	Refrigerant repair shops
Permanent wave solutions	Beauty shops
Fixer, hydrochloric acid (muriatic acid), bromide, iodine	Photo labs, chemical / plastics processing plants
Cement powder, crack fill dust, cellulose, fiber based insulation	Concrete plant or construction site



Do not store or use gasoline or other flammable vapors and liquids in the vicinity of this or any other boiler. Failure to follow instructions may result in serious injury or death.

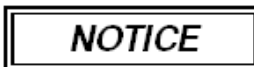

It is **BEST PRACTICE** to pipe the combustion air-inlet directly to the outdoors (Direct Vent installation) to avoid contamination often contained in indoor air.

**Flammable Solvents and Plastic Piping**

Due to the extremely flammable characteristics of most glues, cements, solvents and primers used in the process of joining plastic vent and air-inlet pipe, explosive solvent vapors must be evacuated from the vent and air-inlet prior to start-up. Avoid using excess cement or primer that may lead to pooling inside the pipe assembly. Freshly assembled piping assembly should be allowed to cure for a minimum of 8 hours before applying power to the gas fired boiler. Refer to **Mandatory Pre-commissioning Procedure for Plastic Venting** in this section.



**Flammable Cements and Primers** – It is the installers’ responsibility to familiarize themselves with the hazards associated with explosive solvents and to take all precautions to reduce these risks. Failure to follow these instructions can cause explosions, property damage, injury or death.

**Mandatory Pre-commissioning Procedure for Plastic Venting (PVC or CPVC)**

 **WARNING** Do not apply power to the boiler prior to Step 4 in the Mandatory Pre-commissioning Procedure for Plastic Venting.

- 1) Working with the power turned off to the boiler, completely install the vent and air intake system, securely cementing joints together. If possible, allow primers/cements to cure for 8 hours before firing the burner. If curing time is less than 8 hours, proceed with Steps 2 through 6.
- 2) Maintain the boiler gas supply shut-off valve in the off position.
- 3) Remove the cable from the Spark Ignition Transformer.

 **WARNING** **Spark Ignition Circuit** - Maintain a safe distance (2 inches minimum) from the spark ignition circuit to avoid injury from electrical shock.

- 4) Turn power on to the boiler and apply a heat demand.
- 5) Allow for 3 complete trials for ignition, consisting of pre and post purge of the combustion blower, until an ignition lockout occurs. Repeat the process two more times (i.e. 9 complete ignition sequences in total).
- 6) Turn power off and reconnect the cable to the Spark Ignition Transformer.

**Near Boiler Vent/Air-inlet Piping**

Each CHS boiler is equipped with a short piece of approved CPVC vent pipe which is to be used when venting with PVC. Insert one end into the boiler flue outlet adapter and cement the other to the field venting (see Table 4-4 for approved venting material). The CPVC vent pipe should extend fully into the boiler flue outlet adapter (see Table 4-2). Ensure that the venting system does not apply a load or strain on the boiler flue outlet adapter. The manufacturer recommends using two elbows to create a “swing joint” to reduce potential strain on vent piping and cemented joints. See Figures 4-3 through 4-5 for illustrations.

 **WARNING** **Gasket Seating** - Improper seating can cause leakage and eventual failure of the sealing gasket. Ensure the vent pipe is adequately beveled prior to inserting into the boiler flue adapter. Failure to follow these instructions may result in serious injury or death.

 **WARNING** **PVC Exhaust Venting** – **DO NOT** insert PVC pipe directly into the appliance exhaust adapter, as it can deform from the clamping force of the gear clamp. Failure to follow these instructions may result in gasket failure and/or the dislodging of the exhaust pipe from the appliance adapter, resulting in property damage, serious injury or death.

 **WARNING** **Polypropylene or Stainless Steel Venting** – When using Polypropylene or Stainless Steel piping, the appropriate appliance adapters must be used to transition the appliance vent connections to accept the respective Polypropylene or Stainless Steel venting. See Table 4-3 for a list of approved adapters. Failure to use the correct adapter will result in flue gas leakage resulting in property damage, serious injury or death.

**Universal Appliance Adapters (CHS-154 only)** – Unlike other CHS models, the CHS-154 employs universal Exhaust-vent and Air-inlet appliance adapters that accept 3 in. PVC/CPVC, Polypropylene (PP) or FasNSeal Stainless Steel (SS) piping, without the need for additional adapters. The universal adapters incorporate three seals, one for 3 in. PVC/CPVC pipe (3.5 in. OD), one for 3 in. PP pipe (3.15 in. OD) and one for 3 in. FasNSeal SS pipe (3 in. OD). See Figure 4-2 for gasket identification and pipe insertion depth based on pipe material used.

Figure 4-2 Universal Exhaust-vent & Air-inlet Appliance Adapter (CHS-154 only)

Gasket Identification and Pipe Insertion Depth

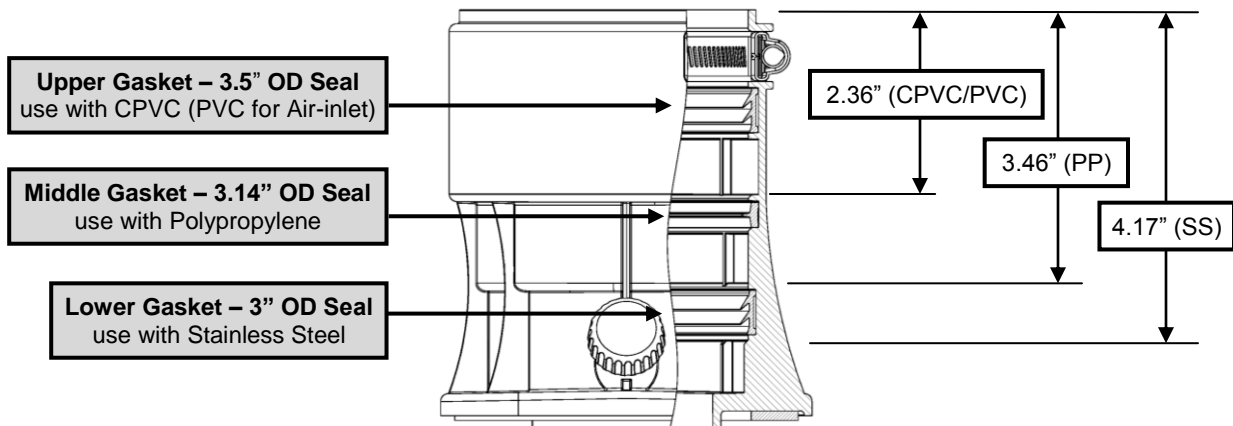

Table 4-2 CPVC Vent Pipe Transition Piece (used when venting with PVC)

Model No.	Vent Pipe Size	CPVC Transition Vent Pipe Length	Full Insertion Depth
CHS 85-110	3"	Minimum 5" [127 mm]	2-7/8" [73 mm]
CHS 154	3"		2-3/8" [60 mm]
CHS 201-285	3"		2-5/8" [67 mm]
CHS 340-399	4"		2-5/8" [67 mm]

Table 4-3 Appliance Adapters for Polypropylene and Stainless Steel Venting

Model No.	Vent Material	Venting Brand	Adapter Part No. <sup>1,2</sup>
CHS 85-110 & CHS 201-285 <sup>3</sup>	Polypropylene	DuraVent – PolyPro®	300150
		Centrotherm – InnoFlue®	ISANY0303
		Z-Flex – Z-Dens®	2ZDCPVCG3
	Stainless Steel	DuraVent – FasNSeal®	300715
Z-Flex – Z-Vent®		2SVSTTA03	
CHS 340-399	Polypropylene	DuraVent – PolyPro®	300151
		Centrotherm – InnoFlue®	ISAA0404
		Z-Flex – Z-Dens®	2ZDCPVCG4
	Stainless Steel	DuraVent – FasNSeal®	303631
		Z-Flex – Z-Vent®	2SVSTTA04.5

Notes:

<sup>1</sup> Listed appliance adapters are only approved for use with the respective venting brand; i.e. a PolyPro® appliance adapter shall not be used with InnoFlue® venting.

<sup>2</sup> Appliance adapters are available from the respective vent pipe manufacturer.

<sup>3</sup> Model CHS-154 utilizes universal exhaust-vent and air-inlet appliance adapters; separate adapters for the venting brands listed in this table are not necessary.



Exhaust venting must be supported to reduce strain on piping joints. Failure to follow these instructions may result in damage, serious injury or death.



In Canada, the first **3 ft (915 mm)** of vent piping must be readily accessible for inspection.

Figure 4-3(a) CHS 85-154 & 340-399

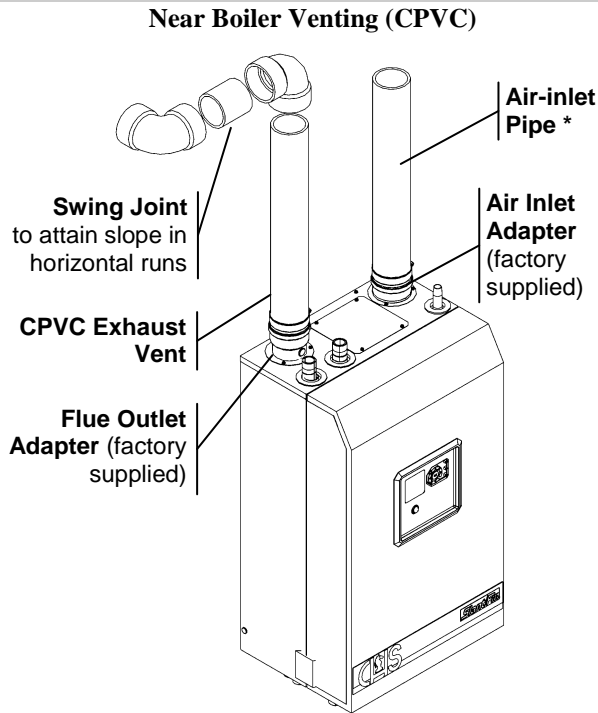
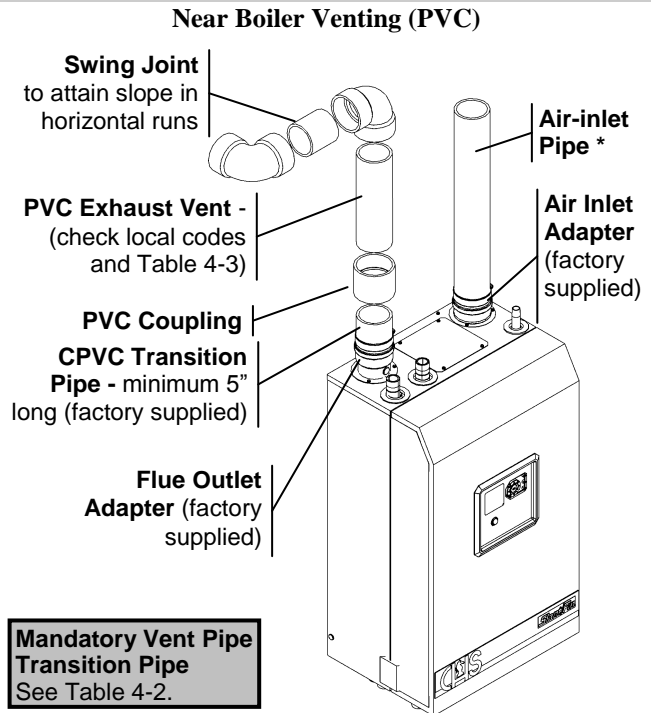

Figure 4-3(b) CHS 85-154 & 340-399



**NOTICE** Boiler Exhaust Vent and Air-inlet connection location varies between models; reference the applicable figure for correct location.

Figure 4-3(c) CHS 201-285

Near Boiler Venting (CPVC)

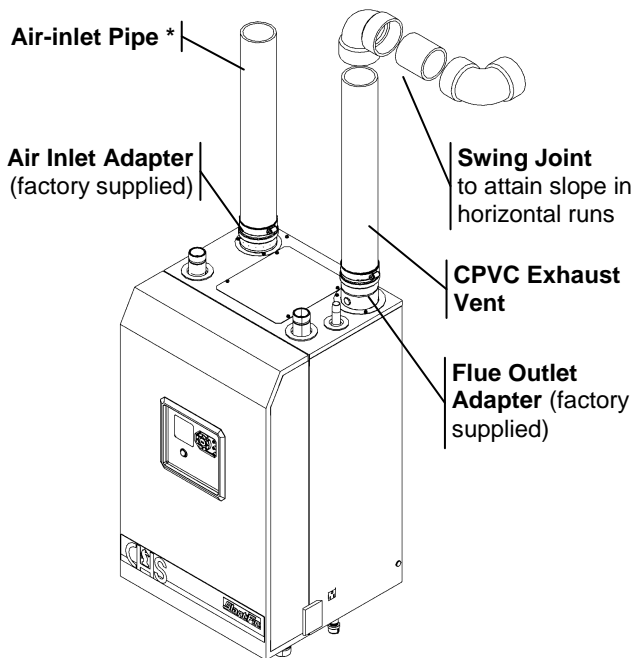
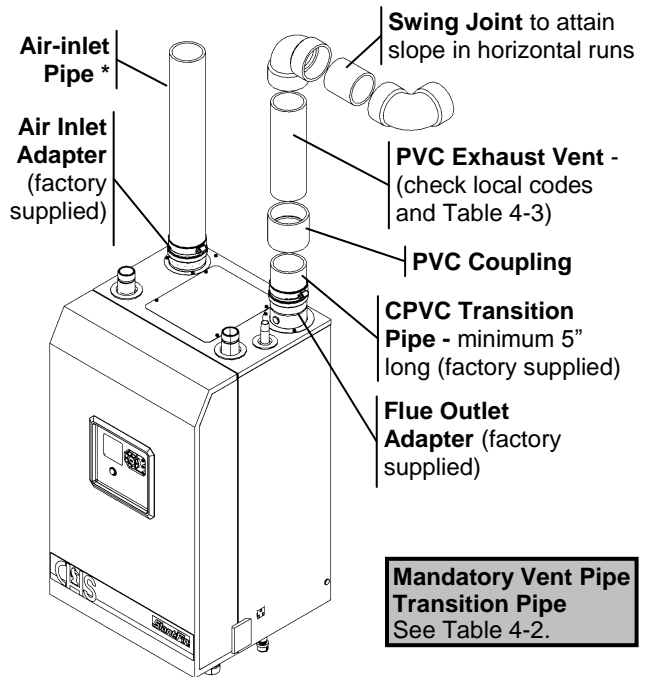

Figure 4-3(d) CHS 201-285

Near Boiler Venting (PVC)



\* Air-inlet - check with applicable local codes for acceptable pipe material.

Figure 4-3(e) CHS 85-154 & 340-399

Near Boiler Venting (Stainless Steel)

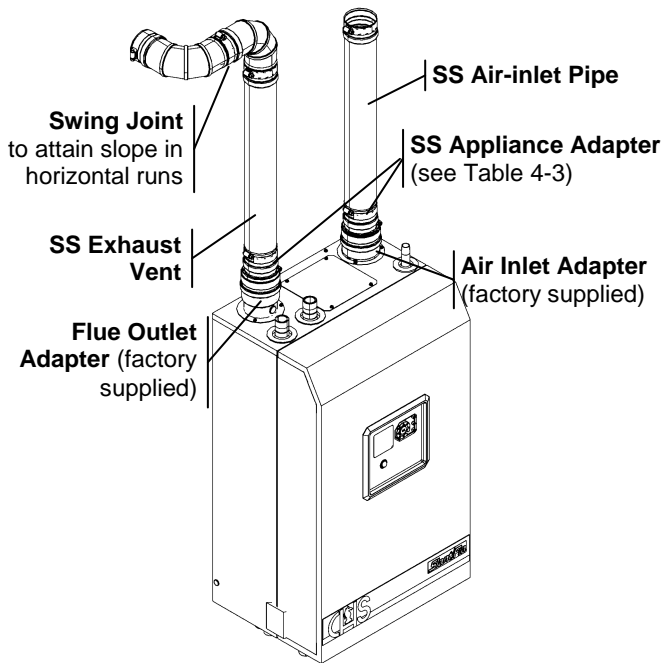
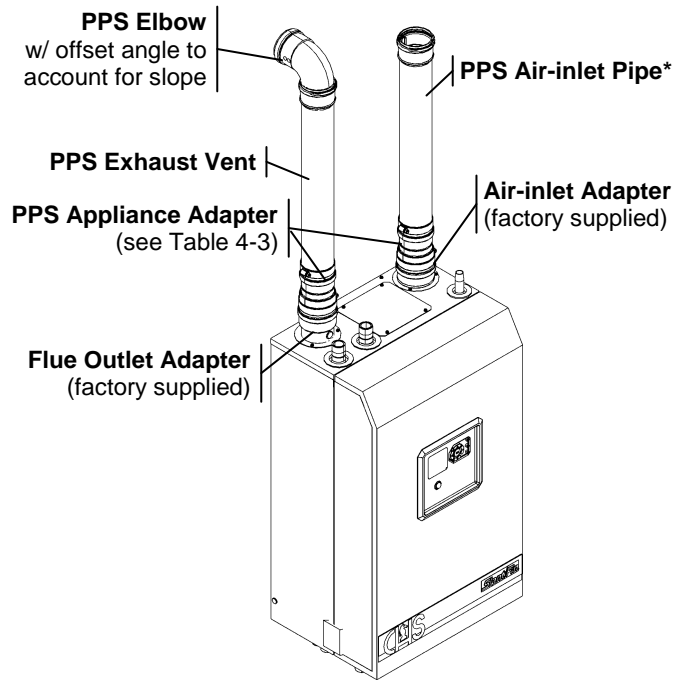

Figure 4-3(f) CHS 85-154 & 340-399

Near Boiler Venting (Polypropylene)



**NOTICE**

Boiler Exhaust Vent and Air-inlet connection location vary between models; reference the applicable figure for correct location.

Figure 4-3(g) CHS 201-285

Near Boiler Venting (Stainless Steel)

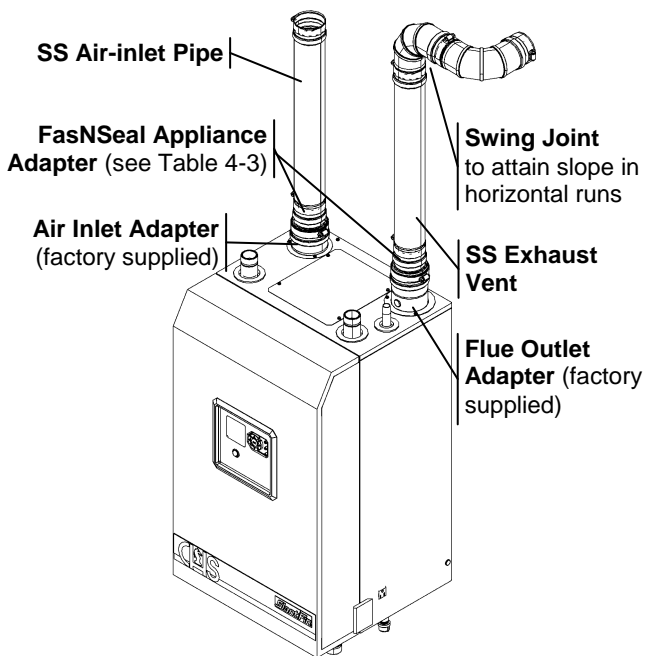
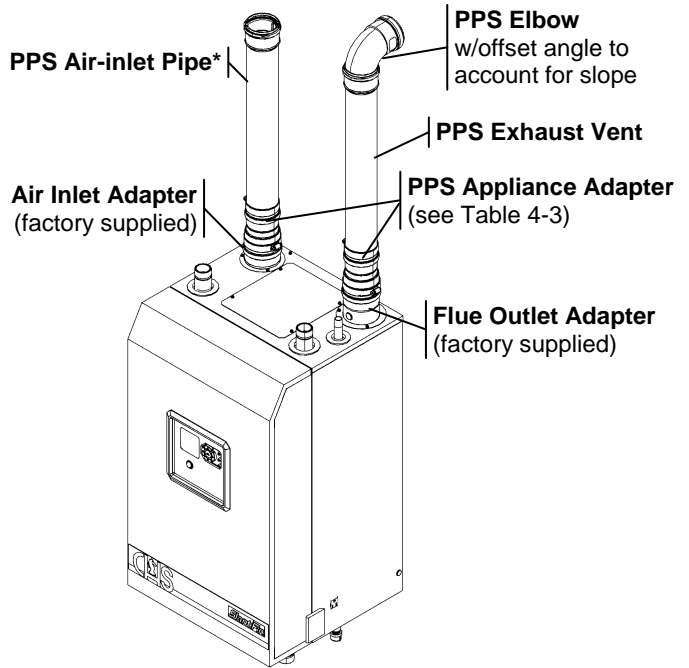

Figure 4-3(h) CHS 201-285

Near Boiler Venting (Polypropylene)



\* Air-Inlet - check with applicable local codes for acceptable pipe material.

**Vent/Air-inlet Pipe Material**

**Table 4-4 Acceptable Vent and Air-Inlet Pipe Material**

Items <sup>1</sup>	Materials <sup>2, 3</sup>	Venting System Standards		 <b>WARNING</b>		
		United States	Canada			
Vent Piping and Fittings	PVC - DWV	ANSI/ASTM D2265	In Canada, all exhaust vent material must be <b>ULC S636 approved.</b>	All Vent and Air-Inlet materials installed on gas fired appliances in CAN/US must meet the Standards listed in this Table. Failure to comply could result in fire, serious injury or death.		
	PVC Schedule 40	ANSI/ASTM D1785				
	CPVC Schedule 40	ANSI/ASTM F441				
	Stainless Steel (SS)	UL-1738				
	Polypropylene (PP)	-				
Pipe Cement	PVC	ANSI/ASTM D2564				
	CPVC	ANSI/ASTM F493				
Primers	PVC / CPVC	ANSI/ASTM F656				

**Notes:**

- <sup>1</sup> Refer to Table 4-5 for Allowable Vent and Air-Inlet Pipe Sizes and Lengths.
- <sup>2</sup> PVC venting (exhaust and air-inlet) is not permitted within the Closet/alcove of a Closet/alcove installation.
- <sup>3</sup> The Air-inlet does not require high temperature pipe material; ABS and PVC Foam Core piping is acceptable. Check applicable local codes for acceptable materials.



The use of cellular core PVC (ASTM F891), cellular core CPVC, or Radel® (polyphenolsulfone) in the exhaust venting system is prohibited. Failure to follow these instructions may result in property damage, personal injury or death.



Covering non-metallic vent pipe and fittings with thermal insulation is prohibited. Failure to follow these instructions may result in property damage, personal injury or death.

**Vent/Air-inlet Pipe Length Determination**

Use Table 4-5 to determine the maximum pipe length that can be used. The table calculates 90° elbows, and 45° elbows at 5 equivalent feet each.

**Example:** When using 3” pipe, a CHS 85-285 can be installed with 150 equivalent feet of air-inlet piping and 150 equivalent feet of exhaust-vent piping. See Table 4-5 for more details.

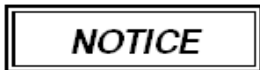

Models CHS 85-110 require a minimum equivalent exhaust vent length of 15’. When operating on Propane, models CHS 85-110 require a minimum air-inlet length of 6’ and 11’ for 2” and 3” venting respectfully.

**Table 4-5 Allowable Vent and Air-inlet Pipe Size and Lengths**

Model No.	Pipe Size	Gas	Length (ft)	Number of Elbows (90’s or 45’s) and Equivalent Feet								
				1	2	3	4	5	6	7	8	9
CHS 85-110	2” <sup>1</sup>	NG	100	95	90	85	80	75	70	65	60	55
CHS-85		LP	35	30	25	20	15	10	5	-	-	-
CHS-110			25	20	15	10	5	-	-	-	-	-
CHS 85-285 <sup>2</sup>	3”	NG/LP	150	145	140	135	130	125	120	115	110	105
CHS 340-399	4”		100	95	90	85	80	75	70	65	60	55

**Notes:**

- <sup>1</sup> See WARNING below.
- <sup>2</sup> Maximum 3 in. vent lengths specified are not applicable to models CHS-155, CHS-175, CHS-200 and CHS-250; consult earlier instruction manuals for maximum vent lengths for earlier models.



**PVC Exhaust Venting** – When using 2” PVC venting with models CHS 85-110, the first seven (7) equivalent feet of exhaust venting must be approved 2” CPVC or 3” PVC; see exceptions in Table 4-4 and Figures 4-2b and 4-2d.



**Termination Options – Direct Vent Installation**

The venting system of the CHS may be terminated using field supplied piping to construct a “Two-Pipe” termination, see Figures 4-4(a), 4-5(a), 4-5(d), 4-6(a), 4-7(a) and 4-7(d); alternatively the venting may be terminated using a factory kit selected from Table 4-7.



**Sidewall Termination** - Due to potential moisture loading (build-up) along the exterior wall, sidewall venting may not be the preferred venting option. Refer to Figures 4-5 and 4-7 for roof top venting options.



The vent for this appliance shall not terminate over public walkways; or near soffit vents or crawl space vents or other area where condensate of vapor could create a nuisance or hazard or cause property damage; or where condensate or vapor could cause damage or could be detrimental to the operation of regulators, relief valves, or other equipment.



Extra precaution must be taken to adequately support the weight of the Vent/Air-inlet piping in applications using roof-top terminations. Failure to follow these instructions may result in venting or boiler component failure resulting in flue gas spillage leading to property damage, serious injury or death.

**Optional Termination Kits – Direct Vent Installation**

Kits certified with the CHS boiler are listed in Table 4-7 and available from the manufacturers listed in Table 4-6. Kits with a Slant/Fin part number listed in Table 4-7, are available directly from Slant/Fin.

**Table 4-6 Optional Termination Kit OEMs**

Venting Brand	Vent Manufacturer	Contact Information
System 636®	IPEX Inc.	www.ipexinc.com
PolyPro®	DuraVent	www.duravent.com
InnoFlue®	Centrotherm Eco Systems	www.centrotherm.us.com
Z-DENS®	Z-Flex Venting Systems	www.z-flex.com

Table 4-6 Optional Vent Termination Kits

Description	Vent Size	Supplier P/N	Figure	Vent Material Compatibility	Vent Option	
					Roof	Wall
IPEX Low Profile (Wall) <sup>7</sup>	2"	196984	4-4(b), 4-6(c)	PVC/CPVC <sup>7</sup>	✗	✓
	3"	196985 (S/F 81 8172 000)				
	4"	196986 (S/F 81 8174 000)				
IPEX Concentric (Wall/Roof) <sup>5,6,7,8</sup>	2"	196125	4-4(c), 4-5(b), 4-6(b), 4-7(b)	PVC/CPVC <sup>7</sup>	✓	✓
	3"	196116 (S/F 81 8173 000), 197117				
	4"	196021 (S/F 81 8175 000), 197021				
PolyPro® Concentric (Wall)	2-4"	2PPS-HK, 3PPS-HK, 4PPS-HK	4-4(d), 4-6(d)	PolyPro® Polypropylene	✗	✓
PolyPro® Concentric (Roof)	2-4"	2PPS-VK, 3PPS-VK, 4PPS-VK	4-5(c), 4-7(c)		✓	✗
InnoFlue® Flush Mount (Wall)	2-3"	ISLPT0202, ISLPT0303	4-4(d), 4-6(d)	InnoFlue® Polypropylene	✗	✓
InnoFlue® Concentric (Wall) <sup>9</sup>	2-4"	(ICWT242 & ICTC0224), (ICWT352 & ICTC0335), (ICWTS462 & ICTC0446)				
InnoFlue® Concentric (Roof) <sup>9</sup>	2-4"	(ICRT2439 & ICTC0224), (ICRT3539 & ICTC0335), (ICRT4679 & ICTC0446)			4-5(c), 4-7(c)	✓
Z-DENS® Horizontal Kit Low Profile (Wall)	4"	2ZDHKLP4	4-4(b), 4-6(c)	Z-DENS® Polypropylene	✗	✓
Z-DENS® Concentric (Wall)	2-4"	2ZDHK2, 2ZDHK3, 2ZDHK4	4-4(d), 4-6(d)			
Z-DENS® Concentric (Roof)	2-4"	2ZDVK2, 2ZDVK3, 2ZDVK4	4-5(c), 4-7(c)		✓	✗

**Notes:**

- <sup>1</sup> Instructions included with termination kits contain detailed assembly and installation instructions.
- <sup>2</sup> All factory termination kits are ULC S636 approved.
- <sup>3</sup> Clearance requirements in this manual supersede those of the instructions included with the vent terminal.
- <sup>4</sup> Piping **MUST** be secured to the vent terminal during installation.
- <sup>5</sup> IPEX Concentric Terminal **MUST** be cemented together and to the vent pipes during installation.
- <sup>6</sup> Vent Screens provided with boiler may be used with the IPEX Concentric Vent Kits; otherwise use IPEX vent screens (2" vent screen P/N 196050; 3" vent screen P/N 196051; 4" vent screen P/N 196052 – each sold separately).
- <sup>7</sup> IPEX Low Profile and Concentric kits (excluding P/N's 197117 & 197021) are constructed out of ULC S636 approved **PVC**; check with your local authority for the acceptance of PVC as a venting material prior to use.
- <sup>8</sup> IPEX Concentric kits can be shortened to fit the requirements of the installation; see instructions included with the kit for more details.
- <sup>9</sup> Centrotherm Concentric termination kits must use the applicable "Twin pipe to concentric adapter," part number ICTC0224, ICTC0335 or ICTC0446.
- <sup>10</sup> 2" Vent Termination Kits may only be used with models CHS 85-154.
- <sup>11</sup> 3" Vent Termination Kits may only be used with models CHS 85-285.
- <sup>12</sup> 4" Vent Termination Kits may only be used with models CHS 340-399.



**PVC In Canada** - Authorities in some jurisdictions may not allow the use of any PVC venting materials with condensing boilers; check with the local safety inspector to verify compliance prior to installing a PVC Concentric Vent Kit with a CHS boiler.

**Sidewall Venting Options – Direct Vent Installation**

Figure 4-4(a)

**Two-pipe Termination (Sidewall)**

**⚠ WARNING**

Location of exhaust and air-inlet connections vary between models, see Figure 4-2. (model CHS 85-110 shown)

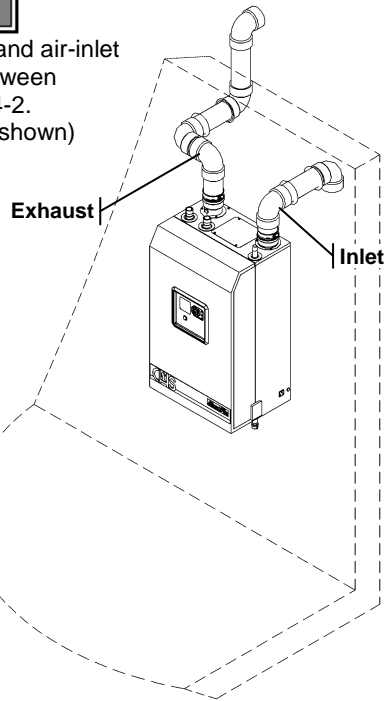

Figure 4-4(b)

**IPEX Low Profile Termination (Sidewall)**

**⚠ WARNING**

Location of exhaust and air-inlet connections vary between models, see Figure 4-2. (model CHS 85-110 shown)

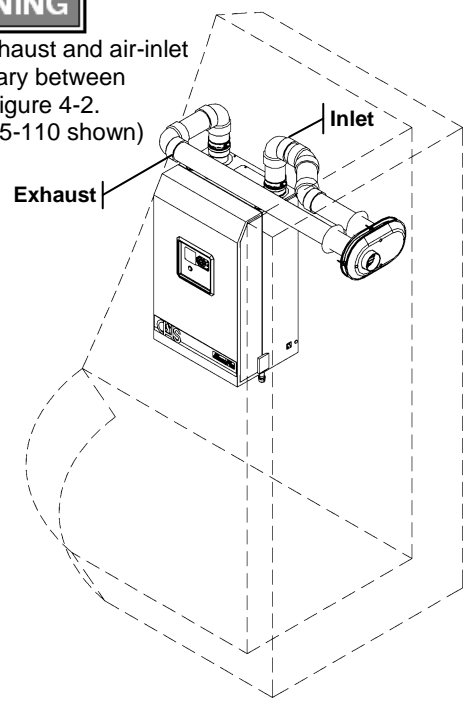

Figure 4-4(c)

**IPEX Concentric Termination (Sidewall)**

**⚠ WARNING**

Location of exhaust and air-inlet connections vary between models, see Figure 4-2. (model CHS 85-110 shown)

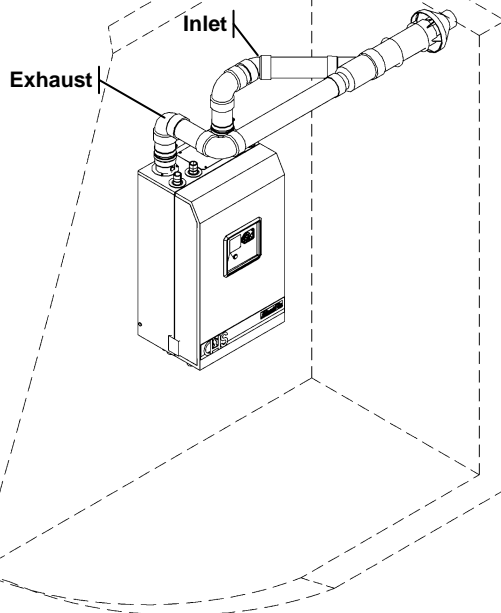
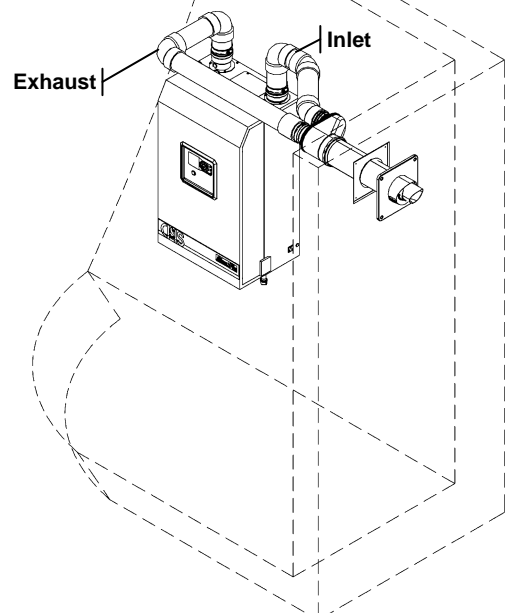

Figure 4-4(d)

**PolyPro / InnoFlue Concentric Termination (Sidewall)**

**⚠ WARNING**

Location of exhaust and air-inlet connections vary between models, see Figure 4-2. (model CHS 85-110 shown)



Roof Venting Options – Direct Vent Installation

Figure 4-5(a)

Two-pipe Termination (Roof)

**WARNING**

Location of exhaust and air-inlet connections vary between models, see Figure 4-2. (model CHS 85-110 shown)

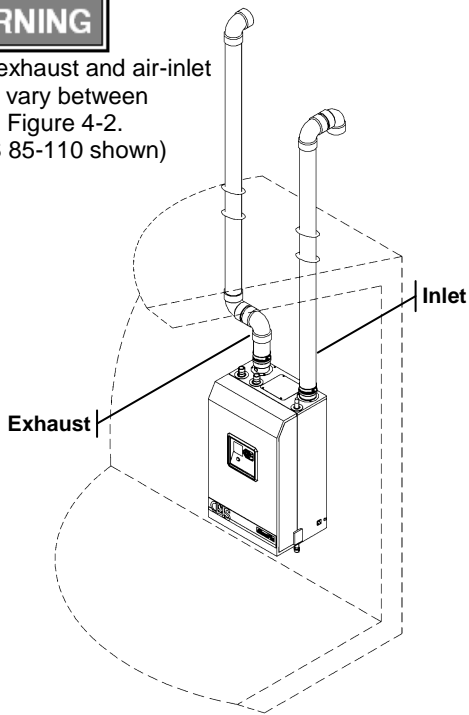

Figure 4-5(b)

IPEX Concentric Termination (Roof)

**WARNING**

Location of exhaust and air-inlet connections vary between models, see Figure 4-2. (model CHS 85-110 shown)

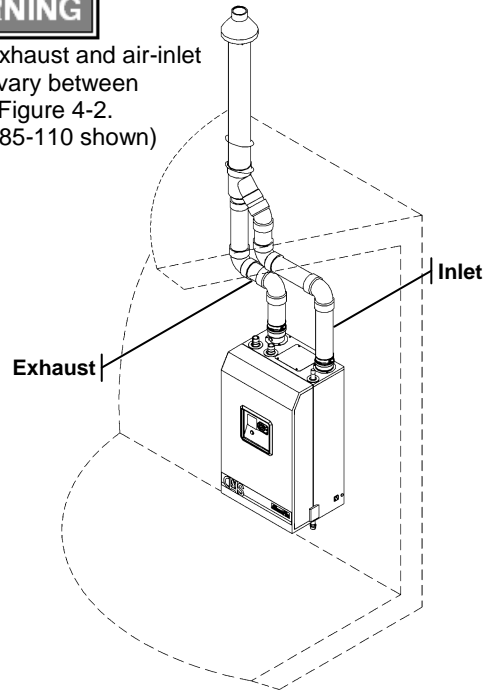

Figure 4-5(c)

PolyPro / InnoFlue Concentric Termination (Roof)

**WARNING**

Location of exhaust and air-inlet connections vary between models, see Figure 4-2. (model CHS 85-110 shown)

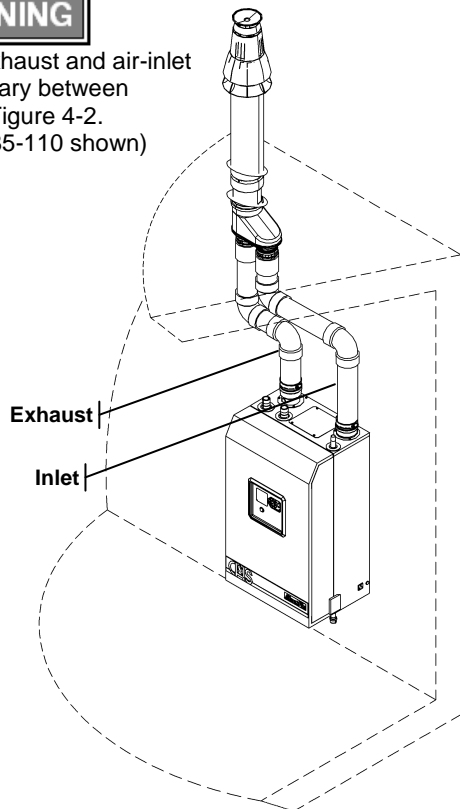
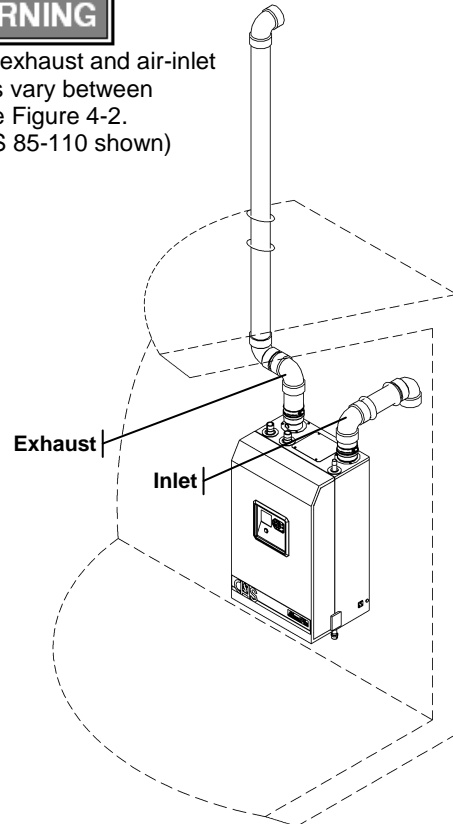

Figure 4-5(d)

Two-pipe Termination (Roof-exhaust / Sidewall-inlet)

**WARNING**

Location of exhaust and air-inlet connections vary between models, see Figure 4-2. (model CHS 85-110 shown)



Sidewall Termination Details – Direct Vent Installation

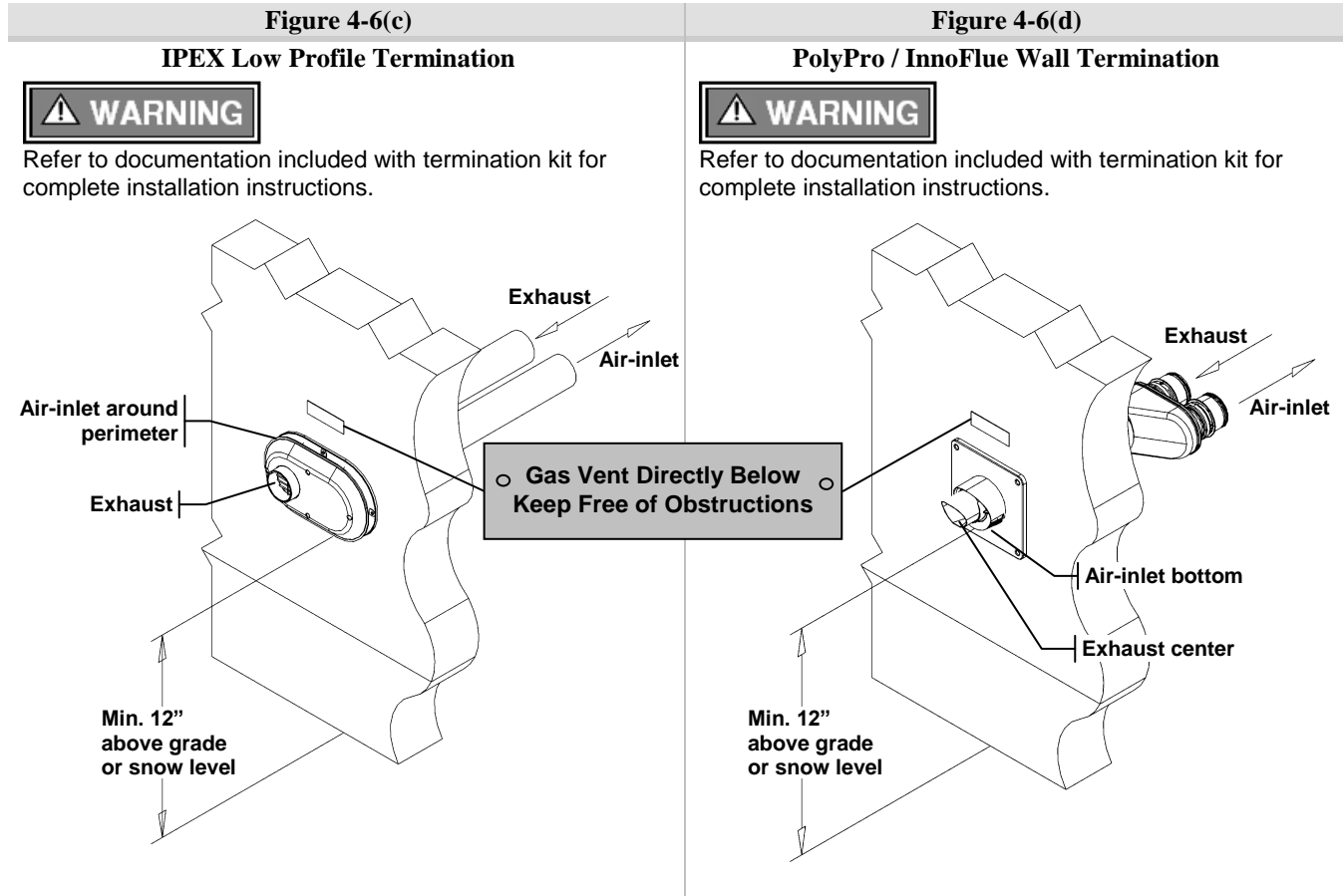
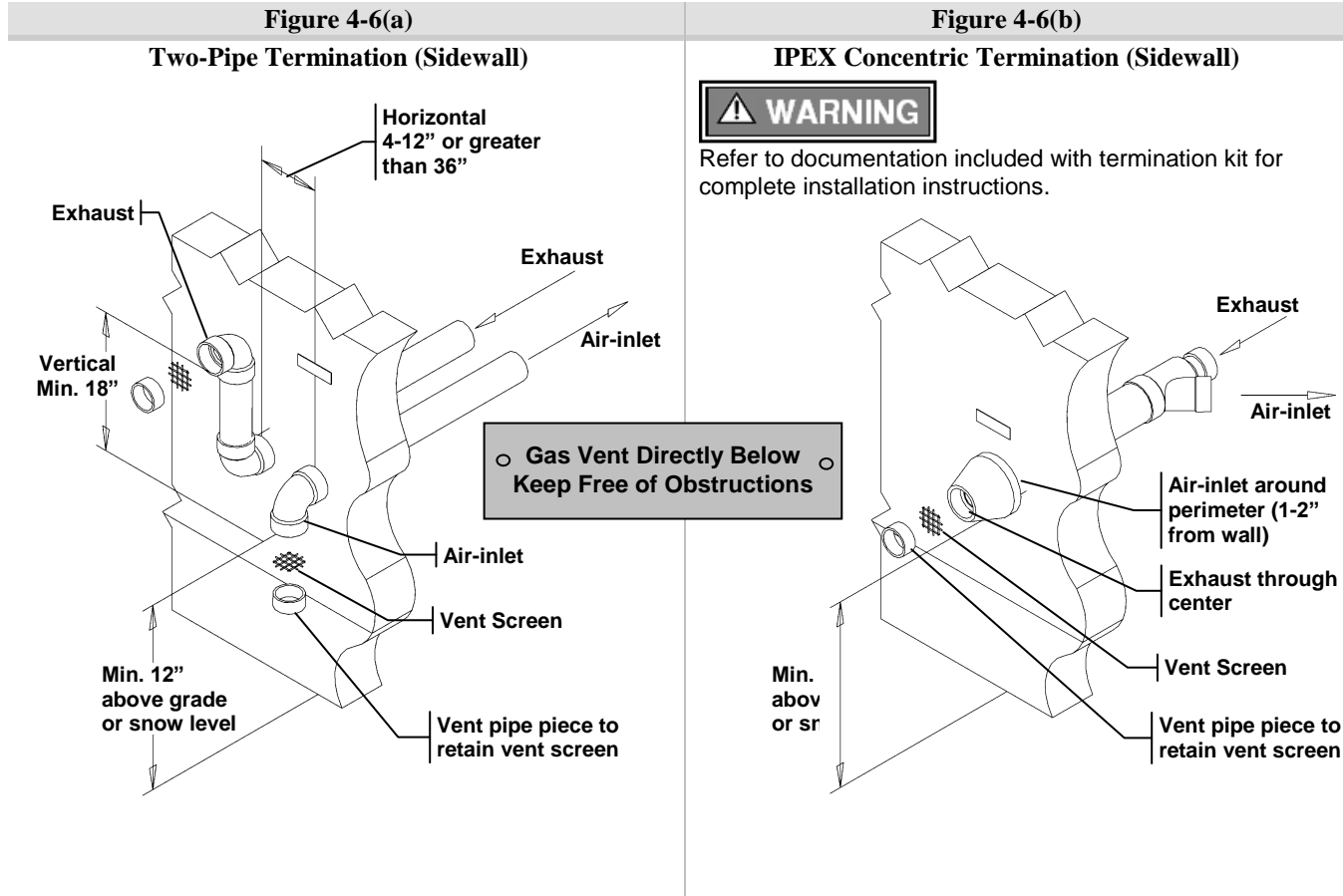

Roof Termination Details – Direct Vent Installation

Figure 4-7(a)

Two-Pipe Termination (Roof)

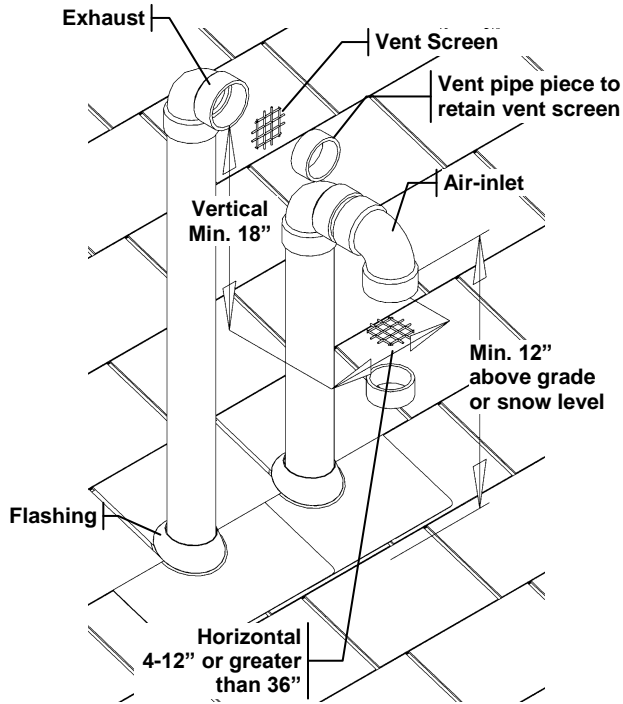

Figure 4-7(b)

IPEX Concentric Termination (Roof)

**WARNING**

Refer to documentation included with termination kit for complete installation instructions.

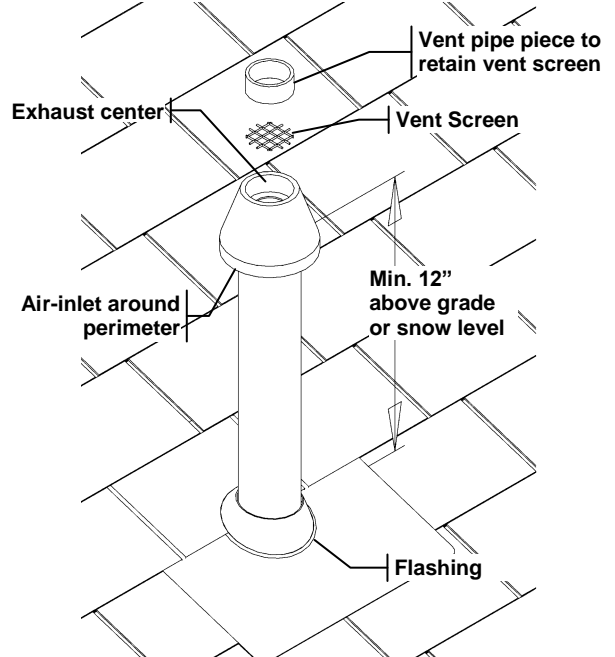

Figure 4-7(c)

DuraVent PolyPro Roof Termination

**WARNING**

Refer to documentation included with termination kit for complete installation instructions.

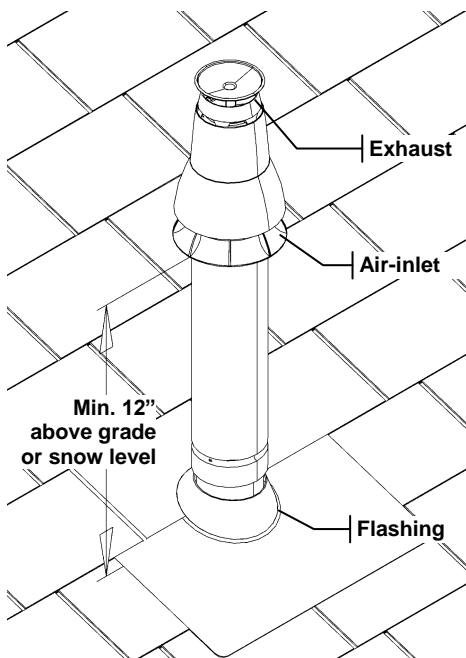
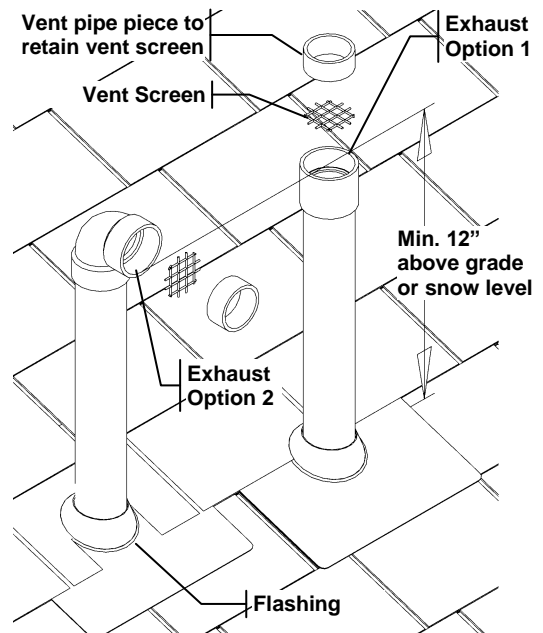

Figure 4-7(d)

Exhaust only Roof Termination

**WARNING**

Figure illustrates two options for exhaust termination only; neither vent pipe illustrated is for combustion air-inlet.



### Venting Rules and Guidelines

1. **Prevailing Winds:** Ensure the vent is located where it will not be exposed to normal prevailing winds.
2. **Combustion Air-inlet Contamination:** Air for combustion must be drawn from an area free of dust and contaminants. Combustion air containing chemicals such as chloride, fluoride, bromine or iodine or dust and debris will cause corrosion damage of the heat exchanger voiding your Slant/Fin warranty. Refer to Table 4-1 for a list of corrosive products and contaminants sources to avoid.
3. **Vertical Separation:** The exhaust must be a minimum of 18" [457 mm] above the air inlet, and the air inlet must always be a minimum of 12" [305 mm] plus snow allowance above any surface that will support snow. (Two feet plus snow allowance is highly recommended). Consult your weather office for the maximum typical snowfall for your region.  
*Example:* New Brunswick Canada - typical maximum snowfall is 19", thus the inlet must be (12"+19") = 31" above grade and exhaust must be (31"+18") = 49" above grade.
4. **Horizontal Separation:** The horizontal distance between the inlet and exhaust must be a minimum of 4" [102 mm] center to center.
5. **Wall Flashing:** Under normal operating conditions this boiler will produce a plume of white gases, and should be taken into consideration when selecting an adequate location. A 36" [915 mm] diameter stainless, plastic, or vinyl shield can be used to flash the exterior of the residence.
6. **Flue Gas Hazard:** Position the vent termination where vapors cannot make accidental contact with people and pets or damage nearby shrubs and plants.
7. **Elbow Extensions:** Elbows on outside of wall must be no more than ½" [13 mm] away from the wall.
8. **Vent Sloping:** All indoor exhaust piping must be on a slope back to the boiler a minimum of ¼" per linear foot of vent [6.25 mm per linear 305 mm]. For applications where excessive condensation is possible ½" per linear foot [13 mm per linear 305 mm] is recommended.
9. **Vent Supports:** Where required Vent and Air-inlet piping shall be secured to the wall for more rigidity. All interior vent pipe shall be supported a minimum of every 36" [915 mm].
10. **Roof Exhaust:** In all roof applications the discharge must point away from the pitch of the roof.
11. **Roof Flashing:** Install adequate flashing where the pipe enters the roof, to prevent water leakage.
12. **Rain Cap:** Install and seal a rain cap over existing chimney openings, in vacant chimney applications.
13. **Venting Below Grade:** For installations that exit the wall below grade refer to Figure 4-8.
14. **Vent Screens:** Install factory supplied vent screens on the outside of the last elbow for both the inlet and exhaust vent terminal elbows. Install the screen into the female opening of the elbow, and then cut a small piece of pipe to sandwich the screen into the elbow. NOTE: ensure the small piece of pipe cut, does not extend past the end of the elbow. Two screens are provided in the package. See Figures 4-6 and 4-7.
15. **Condensate Hazard:** Do not locate vent over public walkways, driveways or parking lots. Condensate could drip and freeze resulting in a slip hazard or damage to vehicles and machinery.
16. **Warning Plate:** For Sidewall Venting, install the warning plate "Gas Vent Directly Below", directly above (within 4 ft [1.22 m] vertically) the location of the air-inlet pipe, so it is visible from at least 8 ft [2.4 m] away. See Figure 4-6.
17. **Wall Thickness:** Direct vent terminations are designed to work with any standard wall thickness. Installation guidelines for min/max wall thickness are as follows: Min.= 1" [25mm], Max.= 60" [1.52 m].
18. **Venting Options:** Due to potential moisture loading (build-up) along the exterior wall, sidewall venting may not be the preferred venting option. Refer to Figures 4-5 and 4-7 for roof top venting options.

**Figure 4-8 Venting Below Grade**

For installations that exit the wall below grade:

1. Excavate site to a point below where the pipes are to exit as shown.
2. Ensure the wall is fully sealed where the pipes penetrate.
3. The Vent/Air-inlet piping MUST be secured to the side of the building above grade, as shown, to provide rigidity.
4. Optional mounting bracket PN. 82075 for securing the exhaust pipes (only applicable for 3" PVC/CPVC venting).
5. Ensure that the Vent/Air-inlet clearances are maintained, see Section 5.0 for details.

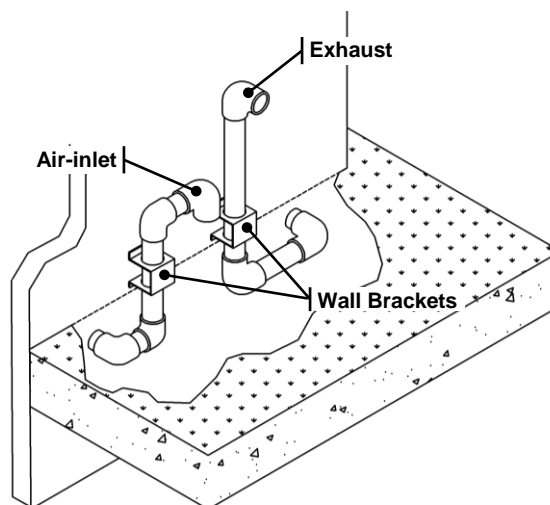

**Figure 4-9 Outdoor Venting**

Vent piping outside the building is permitted under the following conditions:

1. The maximum length outside the building is 20 feet [6.1 m]. Note that outdoor length must be included in the overall vent length calculation.
2. All normal termination clearances are maintained.
3. The pipe is supported every 24" [610 mm].
4. The exhaust and air-inlet are sloped back to the boiler 1/2" elevation for every linear foot [13 mm for every linear 305 mm].

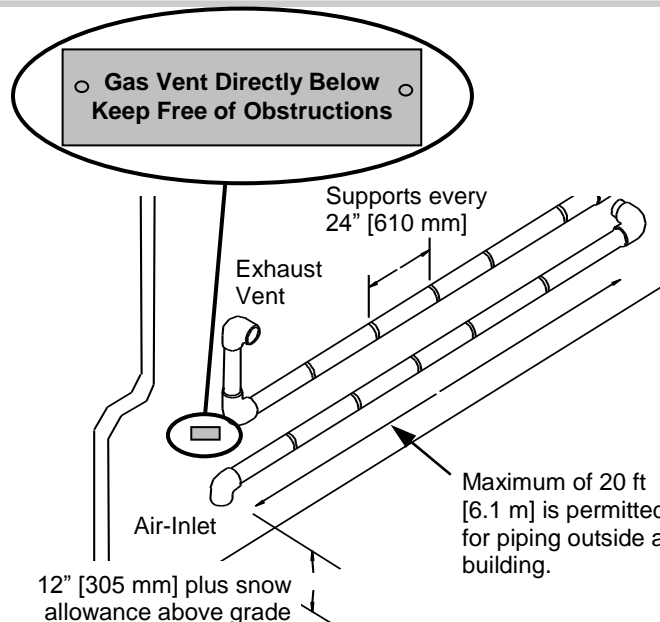

**Figure 4-10 Existing Chimney Chase Way**

It is permissible to use an existing chimney as a chase way to run the Vent/Air-inlet piping as long as:

1. The chimney is not being used by any other boiler.
2. Flue gases don't enter the vacant chimney.
3. Only CHS certified venting materials are used, see Section 4.0.
4. Vent lengths are within the maximums specified.
5. The top of the chimney is capped and the Vent/Air-inlet pipes are flashed to prevent leakage into the vacant chimney.

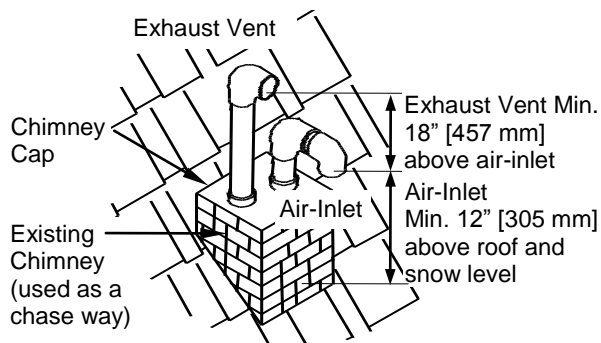

Under no circumstances may an existing chimney or chase-way be used to vent or provide combustion air to a CHS boiler. Failure to follow these instructions will result in fire, property damage, serious injury or death.



**5.0 VENT/AIR-INLET TERMINATION CLEARANCES****WARNING**

The quick reference table below is to be read in conjunction with the numbered notes as indicated, Figures 5-1 and 5-2, and the Venting Rules and Guidelines in Section 4.0. The instructions detailed in this section are a combination of CHS specific and National Gas Code restrictions. Compliance alone doesn't insure a satisfactory installation as good common sense must also be applied. Failure to follow these instructions may result in fire, property damage, serious injury or death.

**Table 5-1 Termination Clearances Quick Reference Table** (See Figures 5-1 and 5-2)

Clearances to Air-Inlet Termination	Canada <sup>1</sup>		USA <sup>2</sup>	
	Min. Distance		Min. Distance	
A Above grade/roofline and snow level <sup>8</sup>	12 in.	305 mm	12 in.	305 mm
B Above roof line - Concentric Vent <sup>6, 11, 13</sup>	24 in.	610 mm	24 in.	610 mm
C To exhaust vent from any other boiler	36 in.	915 mm	12 in.	305 mm
Clearances to Exhaust Vent Termination	Min. Distance		Min. Distance	
D Minimum vertical separation above air inlet <sup>9</sup>	18 in.	457 mm	18 in.	457 mm
E Minimum horizontal separation from air inlet <sup>3</sup>	4 in.	102 mm	4 in.	102 mm
F Window, door or building opening	36 in.	915 mm	12 in.	305 mm
G To combustion air inlet from any other boiler	36 in.	915 mm	12 in.	305 mm
H Non-mechanical air supply inlet to building	36 in.	915 mm	12 in.	305 mm
I Mechanical air supply inlet to building <sup>4</sup>	6 ft.	1.83 m	3 ft.	915 mm
J Soffit, overhang, eave or parapet	24 in.	610 mm	24 in.	610 mm
K Soffit vent or vent opening in an overhang, eave or parapet	6 ft.	1.83 m	6 ft.	1.83 m
L Outside corner <sup>10</sup>	-	-	-	-
M Inside corner of an L-shaped structure (including walls and fences)	36 in.	915 mm	36 in.	915 mm
N Electric meters, gas meters, regulators and relief equipment	6 ft.	1.83 m	4 ft.	1.22 m
P Each side of center line above or below meters, regulators and relief devices <sup>5</sup>	36 in.	915 mm	36 in.	915 mm
Q Above a paved sidewalk, driveway, or parking lot on public property if adjacent <sup>12</sup>	7 ft.	2.13 m	7 ft.	2.13 m
R Above a sidewalk, driveway, or parking lot on public property	<b>x</b>	<b>x</b>	<b>x</b>	<b>x</b>
S Above a sidewalk, driveway on private property between / serving both dwellings	<b>x</b>	<b>x</b>	<b>x</b>	<b>x</b>
T Under a concrete veranda, porch, deck, or balcony <sup>7</sup>	24 in.	610 mm	24 in.	610 mm
U Above, under or near exterior stairs	<b>x</b>	<b>x</b>	<b>x</b>	<b>x</b>
V Into a canopy or carport	<b>x</b>	<b>x</b>	<b>x</b>	<b>x</b>
<b>Notes:</b>				
1 - Canadian installations must comply with the current CSA B149.1 Natural Gas and Propane Installation Code and local building codes.				
2 - US installations must comply with current ANSI Z223.1/ NFPA 54 National Fuel Gas Code and local building codes.				
3 - Horizontal separation center-to-center (c.c.) 4"-12" (102-305 mm).				
4 - For US installations, an exhaust vent may be 3 ft above a mechanical air supply inlet if within 10 ft. [3 m] horizontally.				
5 - Horizontal clearance must be observed up to a height of 15 ft. [4.6 m] above/below the meter, regulator, or relief devices.				
6 - Concentric Vent must protrude from the roof precisely 24" [610 mm] measuring from the terminal end-cap vanes.				
7 - Permitted if veranda, porch, deck, or balcony is made of concrete and a minimum of two sides are fully open beneath.				
8 - 24" is the recommended snow level allowance above grade/roofline or any surface that will support snow, debris, or ice (i.e. for roof venting clearances - roofline and snow level). If living in a snowfall region, consult your local weather office for the maximum typical snowfall for your area.				
9 - Note that the vent must maintain a minimum vertical distance above the air-inlet. Example: Vent height = 18" (457 mm) above air inlet + 12" (305 mm) for air inlet above grade/roof line and snow level = 30" (762 mm) above grade and snow level.				
10- Clearances to an outside corner to be in accordance with local installation codes.				
11- In Canada, concentric vent materials are subject to approval by local inspectors. See Termination Kits in Section 4.0.				
12- Above public walkways, driveways or parking lots if adjacent to it and condensate cannot drip, freeze, or create a hazard.				
13- Contact the manufacturer for special exemptions relating to multiple boiler installations using concentric vents.				
<b>x</b> - Not permitted by National gas code(s) and/or recommended by boiler manufacturer.				

Figure 5-1 Termination Clearance Quick Reference Diagram (See Table 5-1)

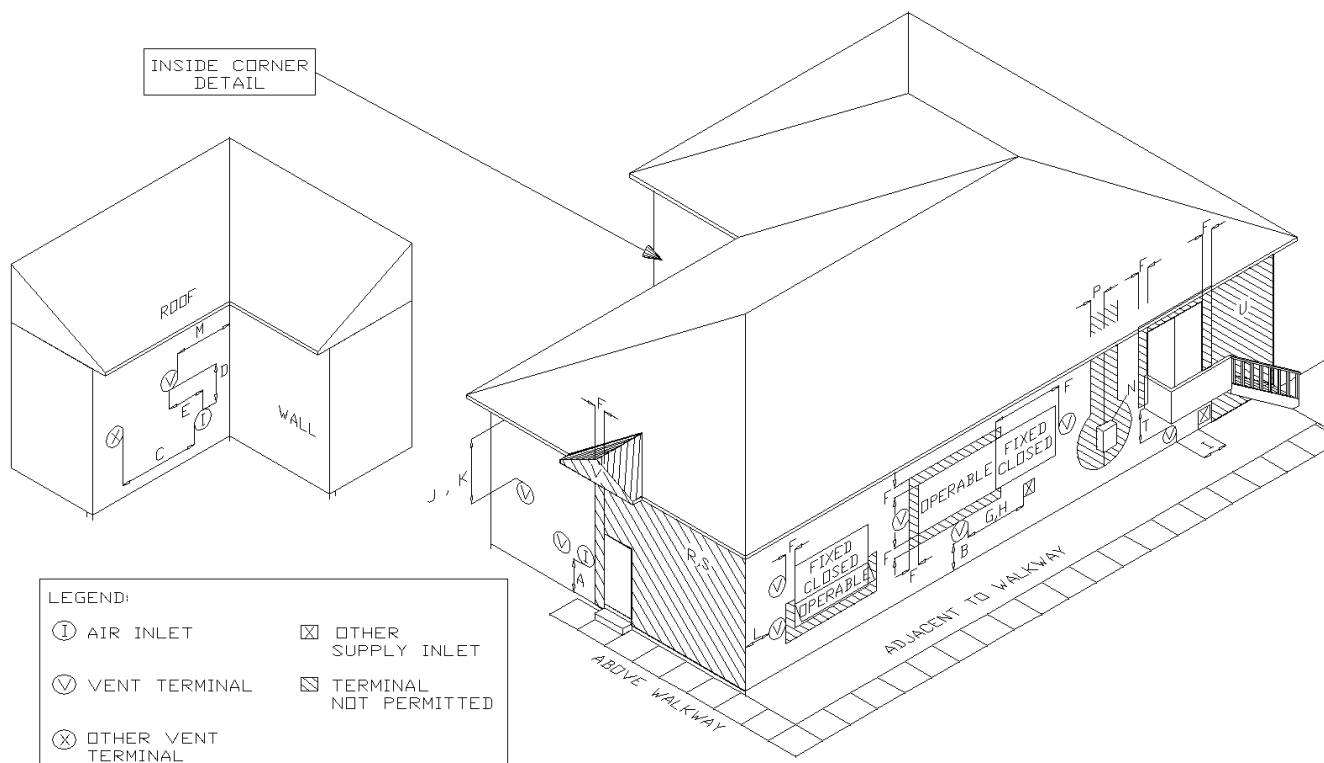

Illustrations of Termination Clearances

Figure 5-2 Sidewall Termination (See Table 5-1)

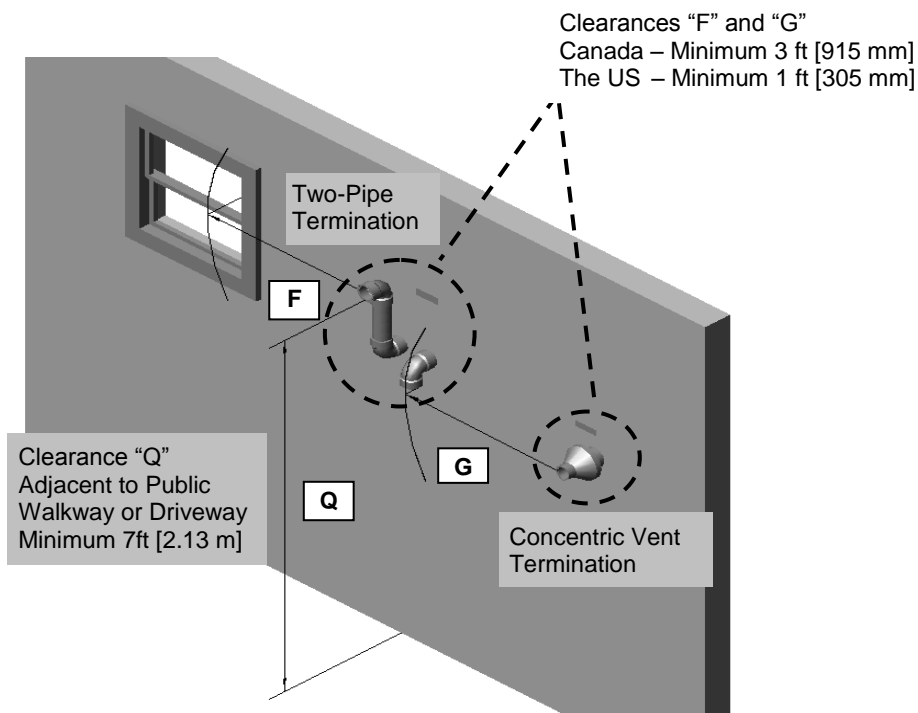

G – Letter represents a specific Termination Position. Refer to Table 5-1 for corresponding termination clearances.

## 6.0 CONDENSATE DRAIN

This unit produces liquid condensate in the heat exchanger and venting system as a product of combustion. Steps must be taken to ensure condensate does not collect in the venting system; therefore, all exhaust piping must slope back to the boiler a minimum 1/4" per linear foot of vent. Condensate must be drained from the unit into a household drain.

### NOTICE

Check with your municipality, or local gas company to determine if the disposal of combustion condensate is permitted in your area (e.g. in the **State of Massachusetts** the condensate must be neutralized prior to entering a drain).

The following are important notes that must be taken into consideration when constructing the condensate drain system (See Condensate Trap Installation Instructions for further details):

- **DO NOT** install condensate lines outside. A frozen or blocked drain will cause the condensate to back-up and leak. This may result in damage to boiler components resulting in a no heat condition; property damage may also occur.
- **NEVER** use copper, steel, or galvanized piping in the construction of the condensate system (condensate is very corrosive and will corrode most metals).
- When a condensate pump is used or required, select a pump that is designed for residential furnaces.

### CAUTION

All tubing, drains and surfaces that come in contact with condensate draining from the boiler, must be constructed out of corrosion resistant material; copper, steel and galvanized are not acceptable materials for draining condensate. Failure to abide by this caution will result in property damage.

### Condensate Trap Installation Instructions (see Figure 6-1)

*(Note: the Condensate Trap is factory supplied with the boiler and must be field installed)*

1. **Inspect Condensate Trap Assembly** – Inspect the Condensate Trap to ensure all parts were shipped with the assembly (see Figure 6-1). The Condensate Trap must be periodically disassembled and cleaned as part of a regular maintenance plan.
2. **Attach Corrugated Outlet Tube** – Remove the **Outlet Retaining Nut** and **Outlet Gasket** and slide components onto the **Corrugated Outlet Tube** – note orientation (gasket should be positioned approximately 1/8" from the edge of the outlet tube – see Figure 6-1). Press the **Corrugated Outlet Tube** into the **Condensate Trap Outlet** and firmly hand-tighten the **Outlet Retaining Nut**.
3. **Attach to Boiler Condensate Drain (A)** – Ensure the **Ball-float** is placed inside the condensate trap, position the **Inlet Gasket** in between the condensate trap and boiler condensate outlet (See Figure 6-1).
4. **Attach to Boiler Condensate Drain (B)** – Secure the **Condensate Trap** into place by firmly hand-tightening the **Inlet Retaining Nut**.
5. **Outlet to Drain** – Route the condensate from the Corrugated Outlet Tube to a household drain, condensate pump or neutralizer (check with your local authority regarding the disposal of condensate), being careful NOT to route it higher than the Condensate Trap outlet (see Figure 6-1).

### CAUTION

The Condensate Trap must be periodically disassembled and cleaned as part of a regular maintenance plan. Failure to clean the trap regularly can cause condensate drain blockage leading to boiler malfunction, property damage and even personal injury.

### DANGER

Carefully follow the above instructions and the accompanying figure – check to ensure the condensate trap is secure to the bottom of the boiler and that no strain is placed on it. Failure to install the condensate trap properly will result in flue gas spillage and leeching of carbon monoxide emissions into the surroundings resulting in serious injury or death.

Figure 6-1 Condensate Drain Piping

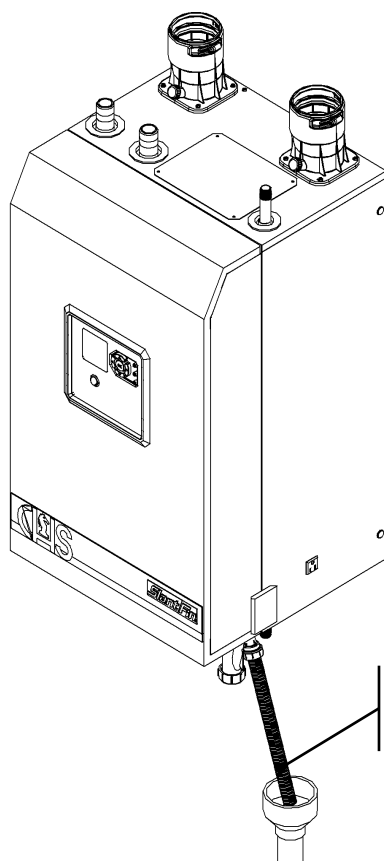
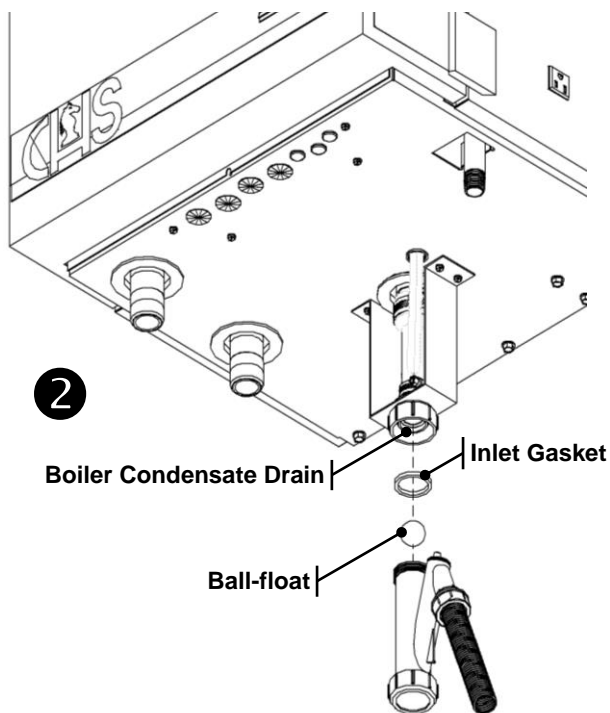
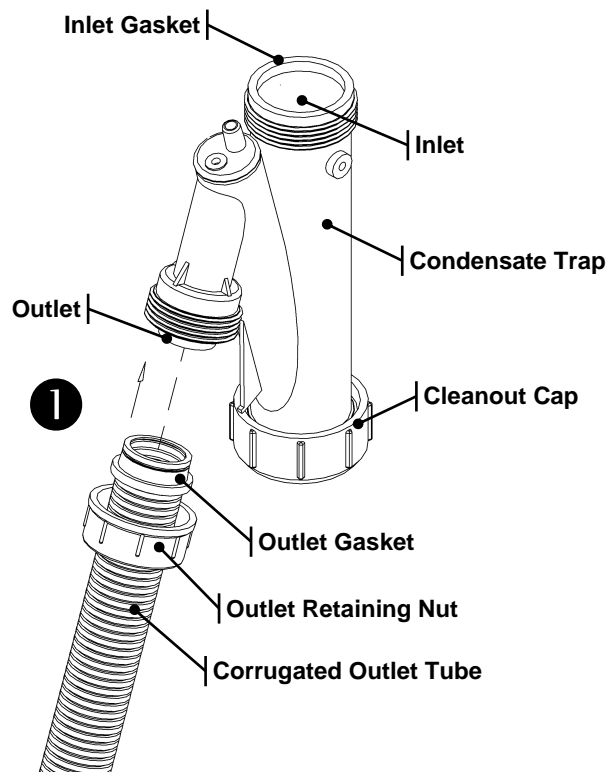

Corrugated Outlet Tube routed to household drain, condensate pump or neutralizer (no strain applied on tubing or condensate drain assembly)

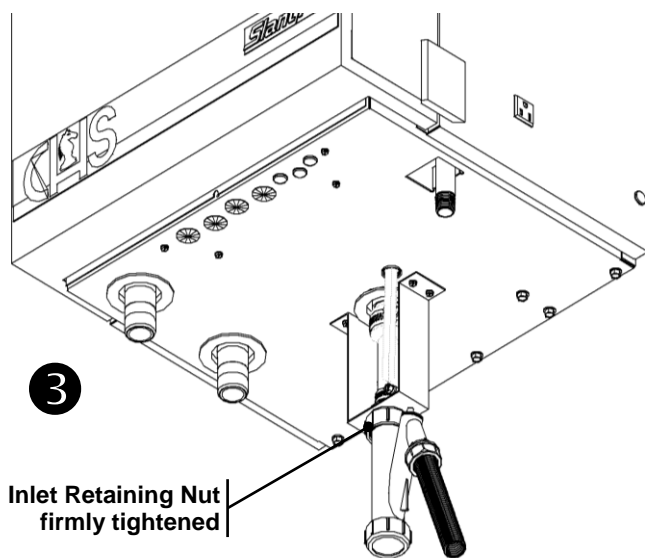

## 7.0 INSTALLING GAS PIPING



CHS boilers are factory set to operate with Natural Gas; **BEFORE OPERATING WITH PROPANE**, the boiler must be converted using the appropriate *Natural to LP Conversion Kit*; see Table 7-1. Failure to properly convert the unit to safely operate with Propane will cause dangerous burner operation, resulting in property damage, serious injury or death.



Liquefied Petroleum (LP) propane gas is heavier than air. Do not install the boiler in a pit or similar location that will permit heavier than air gas to collect. Check with Local Codes as they may require boilers fueled with LP gas to be provided with an approved means of removing unburned gases from the room. Failure to follow these instructions may result in serious injury or death

**Table 7-1 Natural to LP Propane Conversion Kit**

Model	Kit Number	LP-Orifice
CHS-85	81 8124 000	415 (4.15mm)
CHS-110	81 8124 000	52 (5.2mm)
CHS-154	81 8278 000	See Note 1
CHS-201	81 8292 000	See Note 2

Model	Kit Number	LP-Orifice
CHS-285	81 8293 000	5.2mm
CHS-399 (pre s/n 84200) <sup>3</sup>	81 8125 000	74 (7.4mm)
CHS 340-399 (post s/n 95974) <sup>4</sup>	81 8279 000	6.75mm

**Notes:**

<sup>1</sup> The CHS-154 is converted to Propane using a replacement LP-Venturi Insert (81 8245 000), not an LP-Orifice. Follow the Natural Gas to LP Conversion Instructions provided with kit number 81 8278 000.

<sup>2</sup> The CHS-201 is converted to Propane using a replacement LP-Venturi Insert (81 8294 000), not an LP-Orifice. Follow the Natural Gas to LP Conversion Instructions provided with kit number 81 8292 000.

<sup>3</sup> CHS-399's, with a serial number of 84199 and lower are converted to Propane using kit number 81- 8125 000.

<sup>4</sup> CHS-399's with a serial number greater than 95974, and all CHS-340's, are converted to Propane using kit number 81- 8279 000.

### Installation

Refer to the current **National Fuel Gas Code ANSI Z223.1/NFPA 54 or CAN/CGA B149.1** installation codes, and local codes for gas piping requirements and sizing. Pipe size running to the unit depends on:

- Length of pipe.
- Number of fittings.
- Type of gas.
- Maximum input requirement of all gas boilers in the residence.

**Ensure that:**

- The gas line connection to the boiler does not apply any weight to the gas valve. Slant/Fin recommends using approved flexible gas piping (if acceptable by local codes) to connect the boiler to the gas supply (See Figure 7-1 for details).
- You plan the installation so the piping does not interfere with the vent pipe, or the removal of the valve, burner, and serviceable components.
- The Boiler is installed such that the gas ignition system components are protected from water (dripping, spraying, rain etc.) during installation and servicing.
- The gas piping is large enough for all the gas appliances in the home. No appreciable drop in line pressure should occur when any unit (or combination of units) lights or runs. Use common gas-line sizing practices.
- Always use a pipe-threading compound that is resistant to Propane (LP) gas solvent action. Apply sparingly to all male threads, starting at two threads from the end. Over doping or applying dope to the female end, can result in a blocked gas line.
- **DO NOT TIGHTEN FITTINGS WITHOUT SUPPORTING THE GAS VALVE** as damage to the valve or blower motor can occur.
- Install a manual “Equipment Shut-Off Valve” as shown in Figure 7-1. Valve must be listed by a nationally recognized testing laboratory.
- The gas line piping can safely be removed from the boiler for servicing, by strategically placing the gas line shutoff and union; see example in Figure 7-1.
- All gas piping, including gas components in the boiler, are checked for leaks using a “Bubble Test”, prior to operating the boiler.



Strain on the gas valve and fittings may result in vibration, premature component failure and leakage and may result in a fire, explosion, property damage, serious injury or death.



Do not use an open flame to test for gas leaks. Failure to follow these instructions may result in fire, property damage, serious injury or death.



When performing a pressure test on the gas line piping, be sure the boiler is disconnected or isolated if the test pressure is expected to exceed 1/2 PSI (14” w.c.), as damage to the gas valve could occur resulting in fire, property damage, serious injury or death.

Figure 7-1 Gas Line Connection (Typical)

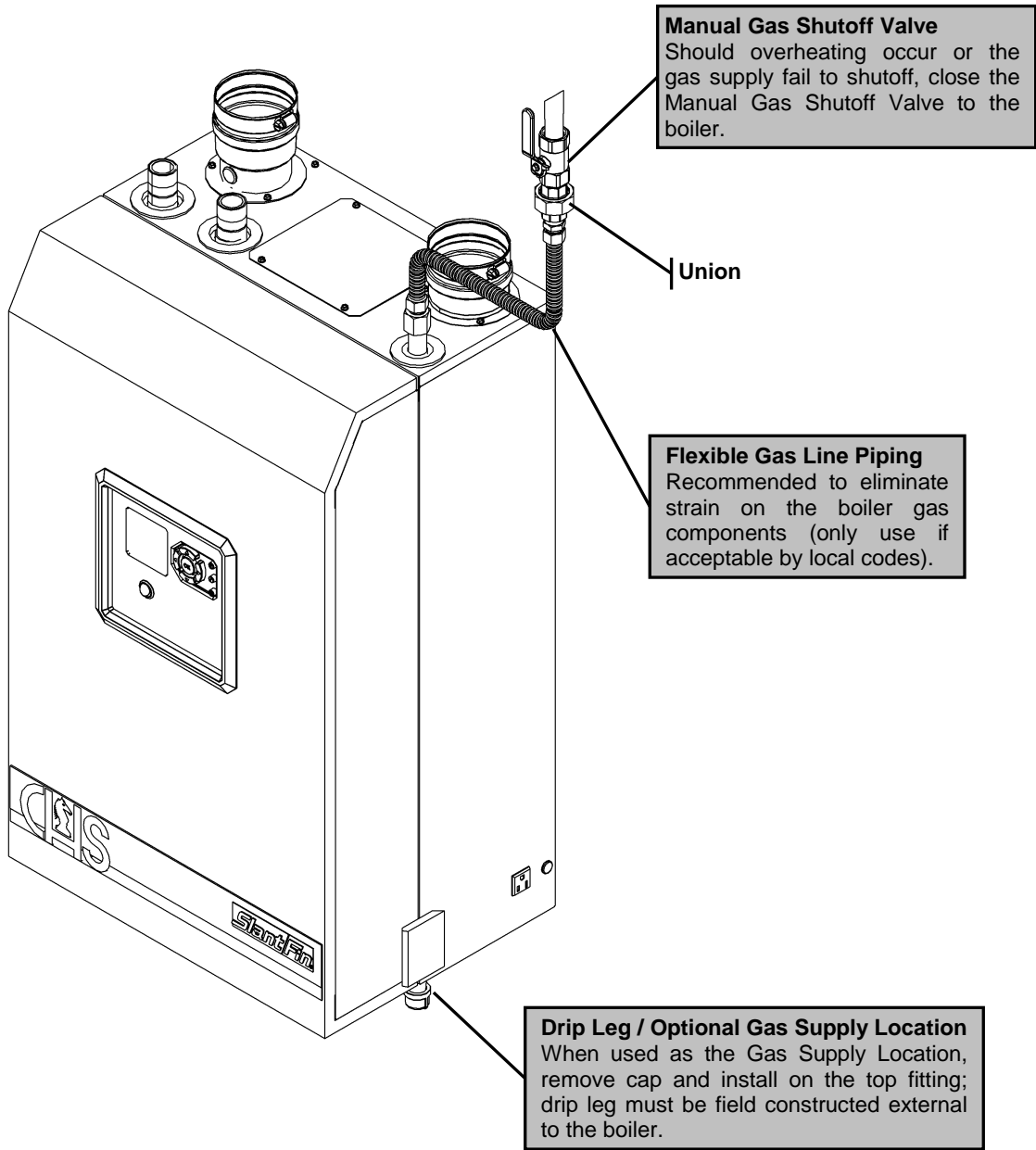

**⚠ WARNING**

Test all gas piping, internal and external to the boiler, for leaks. Failure to follow these instructions may result in fire, property damage, serious injury or death.

**8.0 LIGHTING THE BOILER****⚠ DANGER**

Before Start-up refer to **Mandatory Pre-commissioning Procedure for Plastic Venting** in Section 4.0. Failure to follow these instructions can result in explosions, injury or death.

**⚠ DANGER**

Prior to turning the gas supply on and lighting the boiler, ensure all aspects of the installation are complete and in conformance with the instructions provided in this manual, including the Vent/Air-Inlet, Condensate Drain, and System Water Piping. Failure to precisely follow these instructions will cause a fire or explosion resulting in property damage, serious injury or death.

**⚠ WARNING**

Do not store or use gasoline or other flammable vapors & liquids in the vicinity of this or any other boiler. Failure to follow instructions could result in explosion causing property damage, serious injury or death.

**⚠ WARNING**

If you do not follow these instructions exactly, a fire or explosion may result causing property damage, serious injury or death.

**⚠ WARNING**

Should overheating occur or the gas supply fail to shutoff, close the Manual Gas Shutoff Valve to the boiler. Failure to follow instructions could result in explosion causing property damage, serious injury or death.

**FOR YOUR SAFETY, READ BEFORE OPERATING**

- A) This boiler does not have a pilot. It is equipped with an ignition device which automatically lights the burner. Do not try to light the burner by hand.
- B) BEFORE OPERATING smell all around the boiler area for gas. Be sure to smell next to the floor because some gas is heavier than air and will settle on the floor.  
WHAT TO DO IF YOU SMELL GAS:
  - Do not try to light any boiler.
  - Do not touch any electric switch.
  - Do not use any phone in your building.
  - Immediately call your gas supplier from a neighbor's phone. Follow the gas supplier's instructions.
  - If you cannot reach your gas supplier, call the fire department.
- C) Use only your hand to turn the gas "shutoff" valve. Never use tools. If the handle will not turn by hand, don't try to repair it, call a qualified service technician. Force or attempted repair may result in a fire or explosion.
- D) Do not use this boiler if any part has been under water. Immediately call a qualified service technician to inspect the boiler and to replace any part of the control system and any gas control which has been under water.

**OPERATING INSTRUCTIONS**

1. STOP! Read the safety information above very carefully.
2. Set the thermostat to lowest setting. Turn off all electric power to the boiler.
3. This boiler does not have a pilot. It is equipped with an ignition device which automatically lights the burner. Do not try to light the burner by hand.
4. Turn the manual gas valve to the OFF position. Remove front access panel.
5. Wait five (5) minutes to clear out any gas. Then smell for gas, including near the floor. If you smell gas, STOP! Follow "B" in the safety information above. If you don't smell gas, go to the next step.
6. Turn the manual gas valve ON. Wait an additional five (5) minutes smelling for gas.
7. Replace the front access panel.
8. Set thermostat to highest setting. Turn on all electric power to the boiler.
9. Ignition sequence is automatic. Combustion will occur after a brief fan purge.
10. If ignition does not occur, follow the instructions "To Turn Off Gas To Boiler" and call your service technician or gas supplier.

**TO TURN OFF GAS TO THE BOILER**

1. STOP! Read the safety information above very carefully.
2. Turn off all electric power to the boiler
3. Turn the manual gas valve to the OFF position





The initial lighting of the boiler must be performed by a licensed Gas Technician. Failure to follow instructions may result in property damage, serious injury or death.

- Ensure the boiler is wired in accordance with this manual.
- Ensure the gas shutoff valve is turned on, and that the gas system has been fully tested for leaks.
- Ensure the system is completely filled with water, and that ALL the air is purged out.



Allow primers/cements to cure for 8 hours prior to Start-up. If curing time is less than 8 hours, first perform Steps 2 through 6 of **Mandatory Pre-commissioning Procedure for Plastic Venting** in Section 4.0. Failure to follow these instructions can result in explosion, serious injury or death.

### Initial Start-Up

1. Turn on power to the CHS boiler and turn-up the Thermostat(s). The boiler should run through a purge, and combustion should occur. (The control system has a built-in ignition retry, allowing the system to try at least three times, before locking-out.)
2. With the unit operating at full capacity, verify that the gas line pressure is 4-10.5 inches w.c. for Natural gas, and 9-13 inches w.c. for Propane (See Section 9.0 for details).
3. Using an appropriate Oxygen (O<sub>2</sub>) or Carbon Dioxide (CO<sub>2</sub>) analyzer, take a sample of the flue gas. The sample must fall within the acceptable ranges for CO<sub>2</sub> specified in Table 9-1.
4. Perform at least three lights in succession to ensure proper operation.
5. After the three successive lights, unplug the flame probe, and allow the unit to cycle again. The flame safety system will allow the unit to go through 4 ignition cycles before going to “Hold 110 – Ignition failure occurred”. Once you have confirmed this behavior, replace the wire on the flame sensor, recycle power and reconfirm proper lighting.



The flame probe is located in the burner plate; it has a single white/semi-transparent wire connected to it. DO NOT remove the orange spark cable from the ignition electrode (also located in the burner plate); this device is used for spark ignition and produces 14,000 volts potential which would result in an EXTREME ELECTRICAL SHOCK possibly causing serious injury or death.



If the unit fails to light consistently and smoothly, contact Slant/Fin for technical assistance at (516) 484-2600. Never allow the boiler to operate if the ignition or operation of the burner is rough or erratic. Failure to follow these instructions may result in serious injury or death.

### Re-lighting Unit

1. Stop and read these instructions very carefully.
2. Set the thermostat to the lowest setting, and then turn off all power to the boiler.
3. This boiler does not have a pilot. It is equipped with an ignition device that automatically lights the burner. Do not try to light the burner by hand.
4. Turn the gas shutoff valve to the off position, and then remove the front cover.
5. Wait five (5) minutes to clear out any gas. Then check for gas, including near the floor. If you smell gas “Stop” and follow “B” above (see **FOR YOUR SAFETY, READ BEFORE OPERATING**). If you don’t detect any gas proceed to the next step.
6. Turn the gas shutoff valve to the on position, wait an addition five (5) minutes and check for gas.
7. Replace the front cover.
8. Set the thermostat to the highest setting, and then turn on all power to the boiler.
9. Ignition sequence is automatic, combustion will occur after a brief fan purge. Ignition will retry 3 times.
10. If ignition does not occur, “Turn off the gas and electricity to the boiler” and contact a qualified service technician, or gas supplier.

### Turning Off the Boiler

1. Set the thermostat to the lowest setting, and then turn off all power to the boiler.
2. Turn the gas shutoff valve to the off position.

**9.0 GAS VALVE AND BURNER SET-UP**



Set-up of the CHS gas valve must be performed by a licensed Gas Technician. Failure to perform the set-up correctly may result in incorrect operation, component failure, property damage, serious injury or death.

**Gas Line Pressure**

The boiler gas valve is equipped with a line pressure test port; see Figures 9-1 to 9-3. Use the following procedure to measure the gas line pressure to the boiler to ensure it falls within the range given in Table 9-1:

1. Turn the supply of gas to the boiler off.
2. Open the bleed screw of the line pressure test port approximately 1-1/2 turns. This port is directly connected to the gas line feeding the boiler. See Figures 9-1 to 9-3.
3. Force 1/4" ID tubing over the housing of the line pressure test port; install the other end of the tubing to an appropriate line pressure test gauge or manometer. Ensure both ends of the tubing make a tight connection.
4. Open the supply of gas to the boiler and check for gas leaks.
5. Observe the line pressure under static conditions and compare it to Table 9-1. The pressure will be greatest under static conditions.
6. With all other gas appliances in the application running, operate the burner to the maximum firing rate (See Table 9-2) and compare the observed line pressure with Table 9-1. The pressure will be lowest during the maximum flow of gas.
7. Adjust the gas line pressure to ensure the parameters in Table 9-1 are attained under all conditions. If possible adjust the line pressure to the "Nominal/Desired" value listed in Table 9-1, while the unit is operating at the maximum modulation rate, see Table 9-2.
8. Continue observing the gas line pressure until the completion of the combustion analyses, in case adjustments need to be made.
9. Complete pressure testing, and then return the bleed screw of the Line Pressure Test Port to the closed position.

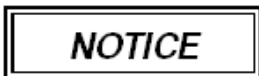

The line pressure is a function of the gas supply and is affected solely by field provided parameters such as line size and regulator settings. Under no circumstances can the boiler gas valve influence or be used to adjust the gas line pressure.



Failure to close the bleed screw of the Line Pressure Test Port will cause a severe leakage of gas, resulting in a fire or explosion causing property damage, serious injury or death.

**Table 9-1 Line Pressure and Combustion Parameters**

Gas	Line Pressure (inches w.c.)			CO <sub>2</sub> (%)		CO (ppm) Max.
	Nominal/Desired	Min.	Max.	Min.	Max.	
Natural	7	4	10.5	8.9	9.5	175
Propane	11	8	13	10.2	10.8	175

**Notes:**  
<sup>1</sup> Combustion calibration must only be performed with the burner operating at maximum modulation rate.  
<sup>2</sup> Combustion values listed are for burner operation at maximum modulation rate; CO<sub>2</sub> and CO values will be lower at minimum modulation rate.  
<sup>3</sup> When tested at minimum modulation rate, the CO<sub>2</sub> must be 0.4-0.8% lower than CO<sub>2</sub> at maximum modulation rate.

**Table 9-2 Minimum and Maximum Modulation Rates**

Model	Min. Modulation Rate (RPM)	Max. Modulation Rate (RPM)
CHS-85	1525	6300
CHS-110	1625	7000
CHS-154	1740	7980 (7500 – LP)
CHS-201	1450	8000
CHS-285	1000	7300
CHS-340	1100	6650
CHS-399 <sup>1</sup>	1050	7800 (7500 – LP)

**Notes:**  
<sup>1</sup> Modulation rates specified for model CHS-399 are for units with serial numbers greater than 90974; consult earlier instruction manuals for modulation rates for earlier serial numbers.





**Carbon Monoxide** - Never leave the unit operating while producing Carbon Monoxide (CO) concentrations in excess of 175ppm. Failure to follow this warning may result in serious injury or death.



**Manifold Pressure** - DO NOT adjust or measure the Manifold Pressure of the boiler. Correct manifold pressure is factory set. Field adjustment could result in improper burner operation resulting in fire, explosion, property damage or death.



Adjustments to the Throttle / Input Screw may only be made by a qualified gas technician, while using a calibrated combustion analyzer capable of measuring CO<sub>2</sub> and CO. Adjustments may only be performed if the gas line pressure is maintained above minimum levels throughout the duration of the test, see Table 9-1. Failure to follow these instructions may result in serious injury or death.

<b>Throttle/Input Adjustment Screw</b>			
Decrease gas Turn Clockwise		Increase gas Turn Counter Clockwise	

**Adjustment**

**Throttle / Input Screw Adjustments** - The boiler is equipped with a Throttle/Input Adjustment Screw, located on the Gas Valve. It is used to adjust the flow of gas leaving the gas valve entering the Venturi and then the combustion air stream. Turn the Throttle screw in (clockwise) to reduce the flow of gas, make combustion leaner, and reduce the concentration of CO<sub>2</sub> in the flue gases. Turn the Throttle screw out (counterclockwise) to increase the CO<sub>2</sub> level and flow of gas in the combustion air stream. Typical adjustment required is 0-1/2 of a turn in or out from the factory setting. See Figures 9-1 to 9-3 for Throttle screw location and Table 9-1 for appropriate CO<sub>2</sub> levels.

**Combustion Calibration** - To calibrate burner operation, perform the following procedure using a calibrated combustion analyzer capable of measuring CO<sub>2</sub> and CO from Natural and Propane Gas burning boilers:

1. Operate the unit at the maximum modulation rate, see Table 9-2.
2. Ensure the gas line pressure is maintained within tolerance, see Table 9-1.
3. While at the maximum modulation rate, measure the CO<sub>2</sub> and CO; adjust as necessary, using the Throttle Screw, to be within the limits listed in Table 9-1.
4. Operate the unit at the minimum modulation rate (Table 9-2). Ensure the combustion remains smooth and CO<sub>2</sub> and CO remain within the limits (Table 9-1). If not, do not adjust further, contact Slant/Fin for assistance.

**Flue Gas Analysis and Adjustment**

Each CHS boiler is factory set to operate with Natural Gas, for boilers field converted to operate with Propane Gas, a flue gas analysis and adjustment is mandatory. See Table 7-1 and Propane conversion instructions.



Failure to perform the flue gas analysis and adjustment detailed in this section may result in erratic and unreliable burner operation, leading to reduced efficiency, increased fuel consumption, reduced component life, heat exchanger combustion deposits, and general unsafe operation. Failure to follow these instructions may result in serious injury or death.

**Analysis** – Perform flue gas analysis, and adjust throttle/input screw as required until CO<sub>2</sub> and CO levels are within acceptable limits.

**Figure 9-1 CHS 85-110 Gas Valve Adjustment**

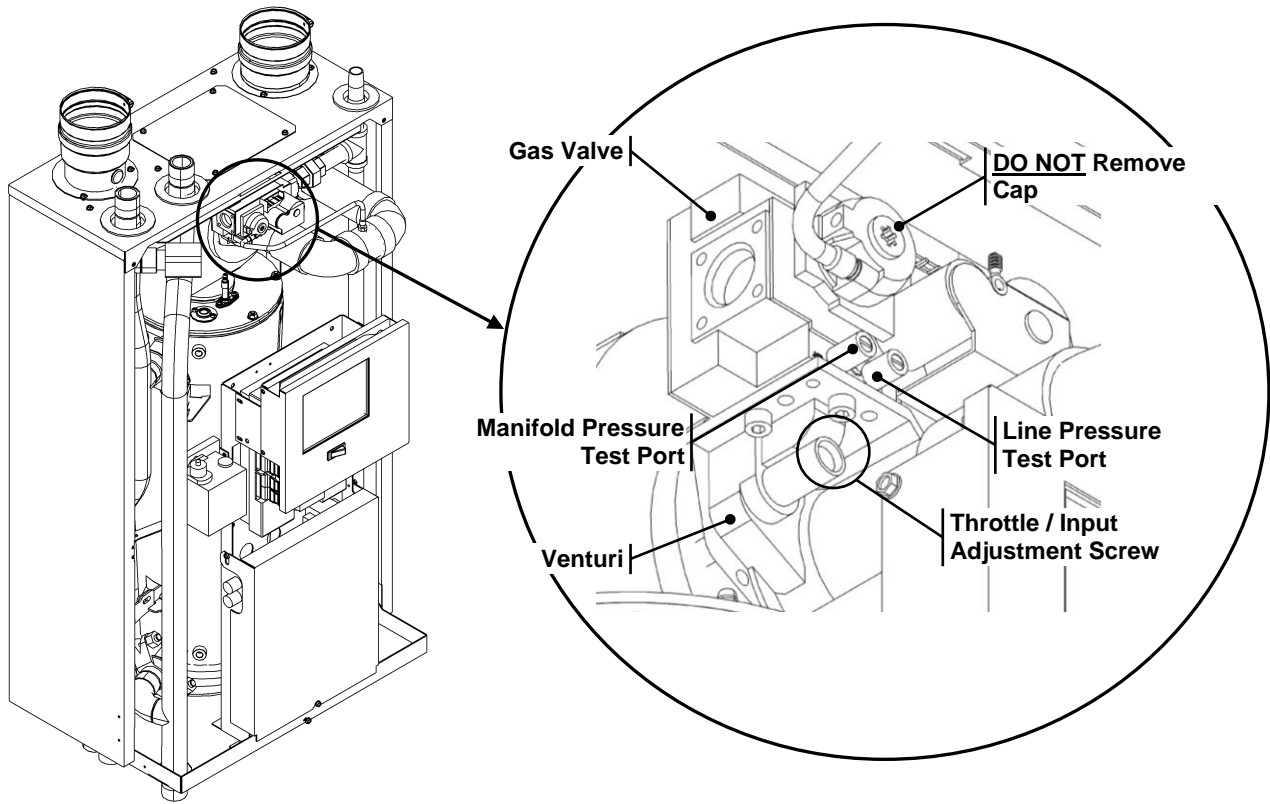

Figure 9-2 CHS-154 & CHS-201 Gas Valve Adjustment

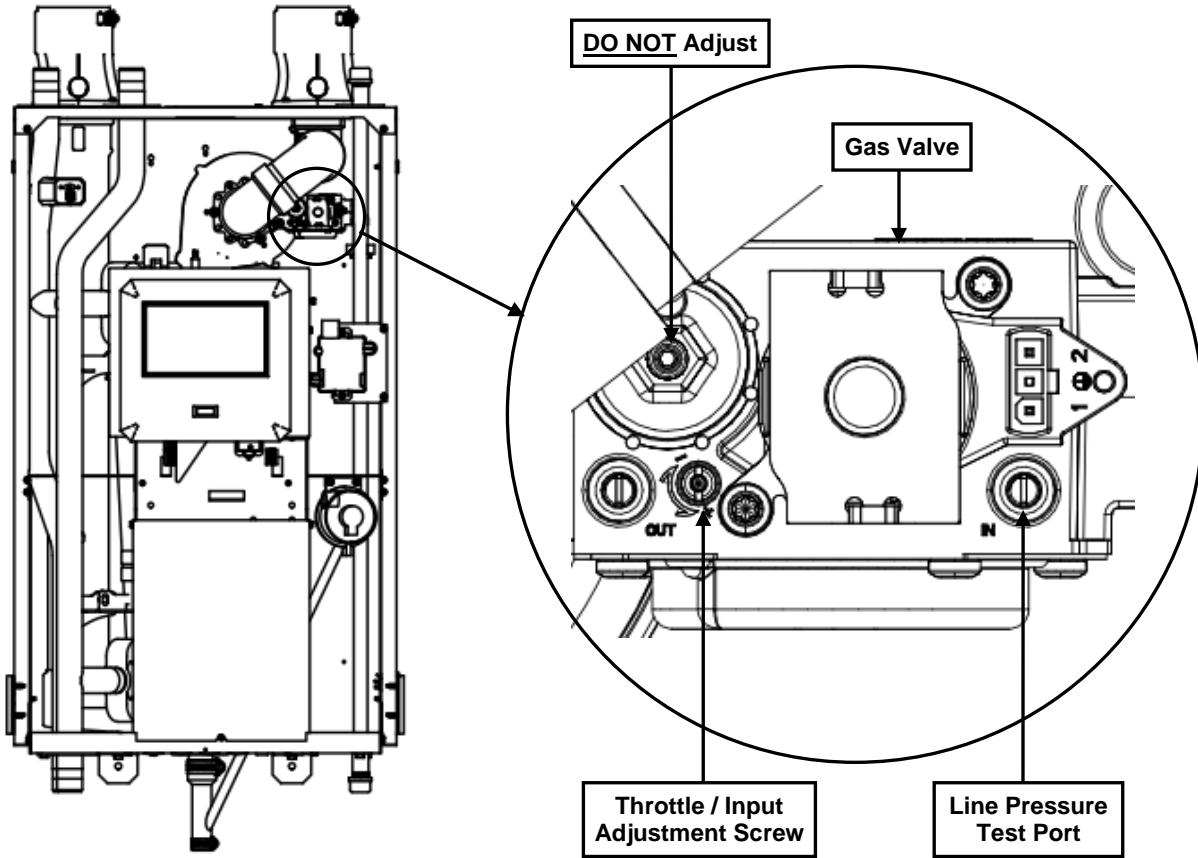
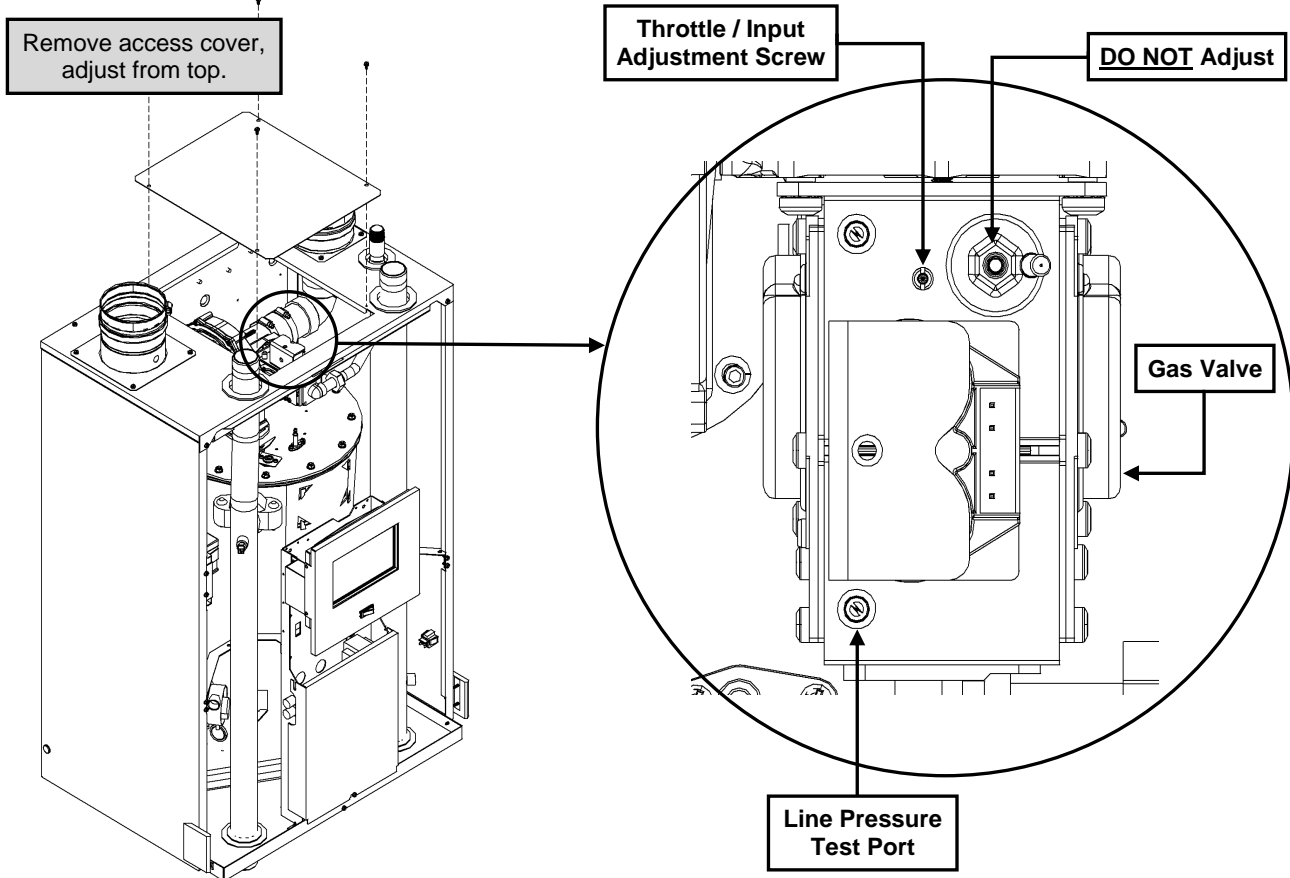

Figure 9-3 CHS 285-399 Gas Valve Adjustment (CHS 340-399 Illustrated)



## 10.0 BOILER AND HEATING SYSTEM PIPING

The fire tube design of the CHS heat exchanger results in minimal head loss, however it must be considered when sizing system piping and circulators. Furthermore, the low mass of the CHS heat exchanger requires a minimum flow rate anytime the burner is operating. To maintain the efficient and reliable operation of the heat exchanger, and to avoid heat exchanger failure, it is critical to ensure the rules and guidelines in this section are followed.



Failure to follow the instructions provided in this section will void the Slant/Fin warranty and may result in property damage, fire, serious injury or death.

### Water Quality

Water Quality is important to the proper operation of the boiler. The following information on water quality provided in this document must be followed. Damage caused by failure to follow these requirements will not be covered by the warranty.

During installation and yearly maintenance, the water quality must be checked. Common water quality heat exchanger failures, are easily prevented when properly addressed.

Follow these system water best practices:

- Test system fill water and understand what you are putting into the system.
- Ensure that there is adequate air elimination in the system.
- Treat all boiler feed water as though it is hard water.
- Use chemical inhibitors on every job.
- Flush old and new systems with fresh clean water before commissioning a new boiler.
- Use magnetic dirt separators on systems containing large amounts of iron.
- Use Dirt Separators to remove debris from system water.
- Where possible, treat boiler feed water.
- Repair system leaks immediately to prevent oxygen (air) and untreated water from entering the system.

Proper equipment must be used to test the water. Digital meters are highly recommended because they can be calibrated. The use of test strips is not recommended because they degrade over time and can be influenced by many factors.

**System Cleaning** – Existing and new heating systems must be cleaned with a hydronic system cleaner; see list of recommended hydronic system cleaners below; equivalent products from other manufacturers may also be used. System cleaner must be drained and thoroughly flushed with clean water to remove any residual cleaner, prior to installing a new boiler. NEVER leave a system cleaner for longer than recommended by the manufacturer of the cleaner; follow the instructions provided by the system cleaner manufacturer.

- Noble Noburst Hydronic System Cleaner
- Fernox F3 Cleaner
- Rhomar Hydro-Solv 9100
- Sentinel X400

**Air Elimination** – A micro bubble air elimination device must be installed on every boiler installation. An air scoop is not an acceptable substitute for a micro bubble air elimination device and should not be used in a CHS installation. Below are a few examples of acceptable devices.

- Spirovent
- Taco 4900 series
- Caleffi Discal

Automatic feed valves should not be left open indefinitely. In the event of a leak, an automatic feed valve will continue to supply fresh untreated water into the heating system. Fresh water contains both oxygen and added minerals, one or both of these could lead to scaling and/or corrosion of the heat exchanger.

**Dirt Removal** – A dirt removal device should be installed in all systems. In older systems containing cast iron radiators/baseboard or large amount black iron or steel pipe a magnetic dirt separator must be installed.

**Glycol, Snow Melt, and Oxygen Permeable Piping** – When freeze protection is required only multi metal inhibited propylene glycol is allowed for use with the boiler; a minimum of 20% and a maximum of 50% are allowed for use with boiler system. If the boiler is being used with a snow melt system that requires a concentration of glycol higher than 50% then a plate heat exchanger is required to be used to separate the snow melt system from the boiler water. In addition, if oxygen permeable piping (non-oxygen barrier tubing) is used in the system a plate heat exchanger is required to be used to separate it from the boiler water.

**NOTICE**

Ethylene glycol is prohibited for use with the boiler, only inhibited propylene glycol is allowed for use with the boiler.

**Water Treatment** – When filling the boiler system, the water must be tested. Table 10-1 outlines the parameters that should be tested for, and the corresponding ranges that are permitted. Water quality that does not fall within the stated ranges will void the warranty of the boiler. Utilize proper testing equipment, such as digital meters, to verify water quality.

**NOTICE**

Never use petroleum based compounds in the system for cleaning or sealing.

Inhibitors should be used for all installations in both new and existing heating systems. Follow the instructions provided by the inhibitor manufacturer when adding it to the system to ensure the correct concentration. A list of approved inhibitors is provided below.

- Rhomar Pro-tek 922
- Sentinel X100
- Fernox Protector F1

**Table 10-1 Boiler System Cleansers and Corrosion Inhibitors**

Parameter	Range	Information
pH	7 to 9	The total pH scale ranges from 1 to 14, with 7 considered to be neutral. A pH less than 7 is said to be acidic and solutions with a pH greater than 7 are basic or alkaline.
Conductivity	100 to 300 $\mu$ S/cm	Conductivity is an indirect method of determining the total dissolved solids in the water. High conductivity in <i>untreated</i> water indicates hard water. Adding corrosion inhibitors will increase conductivity.
Hardness	50 to 200 ppm (3 to 11.7 gpg)	Artificially soft water can damage the system. The use of unsoftened water is recommended. Do <b>not</b> use distilled or purified water.
Chlorine	150 ppm	High Chlorine content in the water can damage the boilers heat exchanger.
Glycol (if applicable)	20-50%	Concentrations below 20% can promote bacteria growth, and concentrations above 50% will dramatically reduce efficiency and may require de-rating the boiler. Inhibited glycol mixed at 50% should have a pH 8-9. Check with glycol manufacturer.
Total Dissolved Solids (TDS)	50 to 300 ppm	TDS includes calcium and magnesium associated with lime scale but also includes other harmful solids such as magnetite, chlorides, sodium and other organic and inorganic materials.
Bacteria/Mold	none	Glycol above 20% will kill any bacteria.
Molybdate Corrosion Inhibitor	100 to 300 ppm	Film-forming inhibitor that protects against iron corrosion.

## Near Boiler Plumbing

CHS boilers are intended solely for use in pressurized closed-loop heating systems operating with a minimum pressure of 15 PSI at the boiler outlet. Carefully follow the instructions and piping diagrams illustrated in this section.

**NOTICE**

The CHS boiler is not approved for operation in an “open system”, thus it cannot be used for direct potable water heating or process heating of any kind.

**Pressure Relief Valve** - A Pressure Relief Valve is factory supplied with each unit. CHS boilers have a maximum allowable operating pressure of 30 PSI (80 PSI for models CHS 201-399). The pressure relief valve must be installed at the boiler outlet and in the vertical position, as shown in Figures 10-1 through 10-3, with the drain pipe outlet exiting the side of the pressure relief valve horizontally and elbowing downward.

**CAUTION**

If installed in the incorrect orientation (horizontally with drain pipe out the bottom) the relief valve may not function properly resulting in property damage or personal injury.

**WARNING**

Ensure the discharge of the pressure relief is piped to a location where the steam or water will not cause property damage or serious injury.

**Pressure & Temperature Gauge** – CHS units come with a factory supplied Pressure and Temperature Gauge. The gauge must be installed at the boiler outlet prior to any circulators. See Figures 10-1 through 10-3.

**Auto Air Vent** – Install the factory supplied auto air vent directly above the outlet fitting on the top of the unit; see Figures 10-1 through 10-3 illustrating the correct location. Open the auto air vent’s vent-cap to promote the removal of air during commissioning of the boiler and to avoid malfunctioning of the LWCO. Once the air is removed from the system, close the vent-cap to prevent water from leaking onto the boiler.

**Low Water Cutoff (LWCO)** – CHS boilers are provided with a factory installed LWCO switch which incorporates a Test Button and Power and Low Water indicator lights. Perform the following Operational Test Procedure before placing the boiler in service, and ensure Maintenance is carried out with the following schedule.

**WARNING**

Do not run the boiler unattended until the following procedure is completed. Failure to follow procedure may lead to unsafe boiler operation resulting in fire, property damage and loss of life.

### Operational Test Procedure (LWCO)

1. Before introducing water to the boiler, turn the power on; both the green “POWER” LED and amber “LOW WATER” LED should illuminate. Generate a burner demand; the burner should not fire and “Lockout 67 ILK OFF” should appear on the screen. Contact Slant/Fin for assistance if this does not happen.
2. Fill the boiler with water; the “LOW WATER” LED should turn off. Clear the Lockout from the display board; burner should fire.
3. With the burner firing, press the TEST button to simulate a low water condition; the amber “LOW WATER” LED should illuminate and the burner should turn off.

### Maintenance (LWCO)

- Every Year – perform Step 3 from the Operational Test Procedure.
- Every 5-years – Remove the LWCO and clean all surfaces in contact with water.



Near Boiler Piping (CHS 85-154)

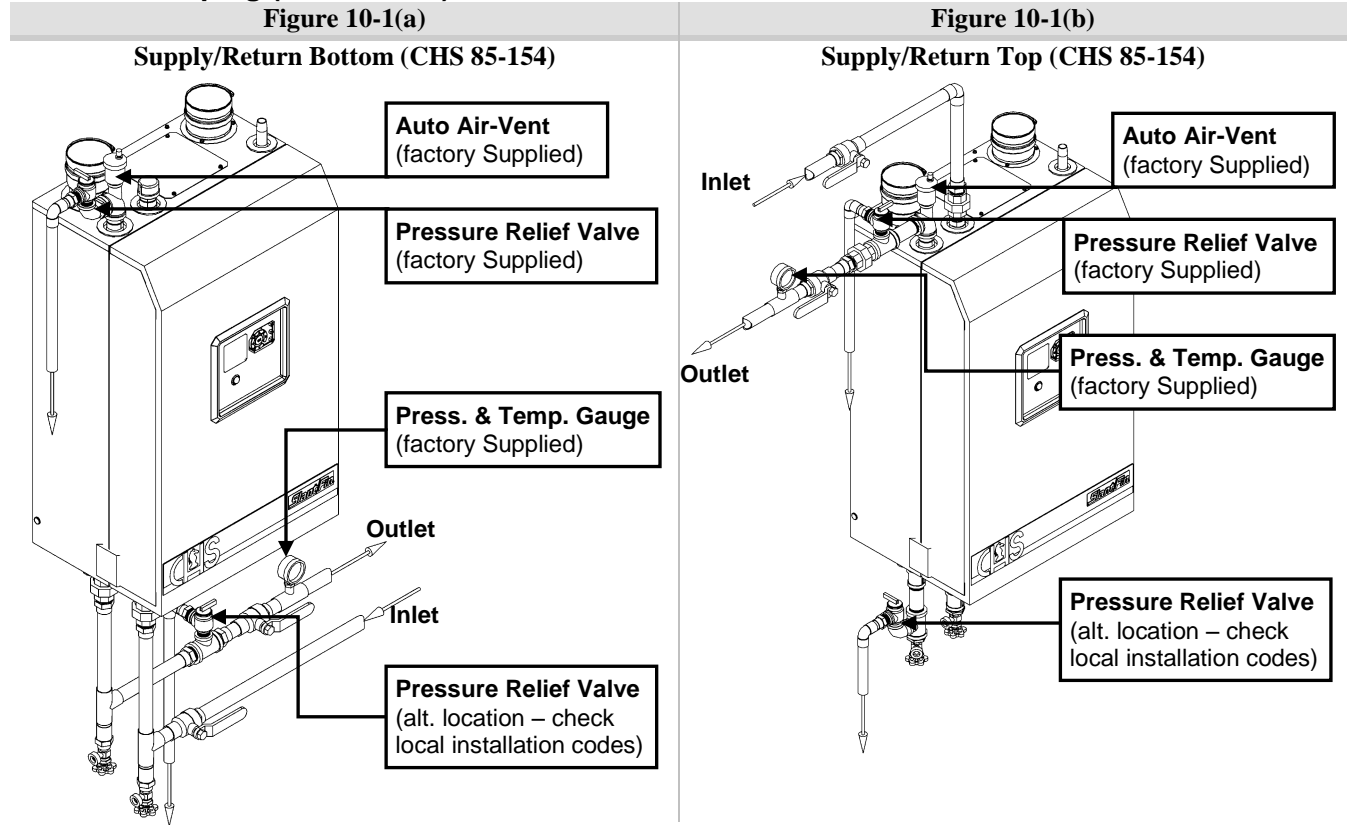

**NOTICE** Boiler Inlet and Outlet water connection location varies between models; reference the applicable figure for correct location.

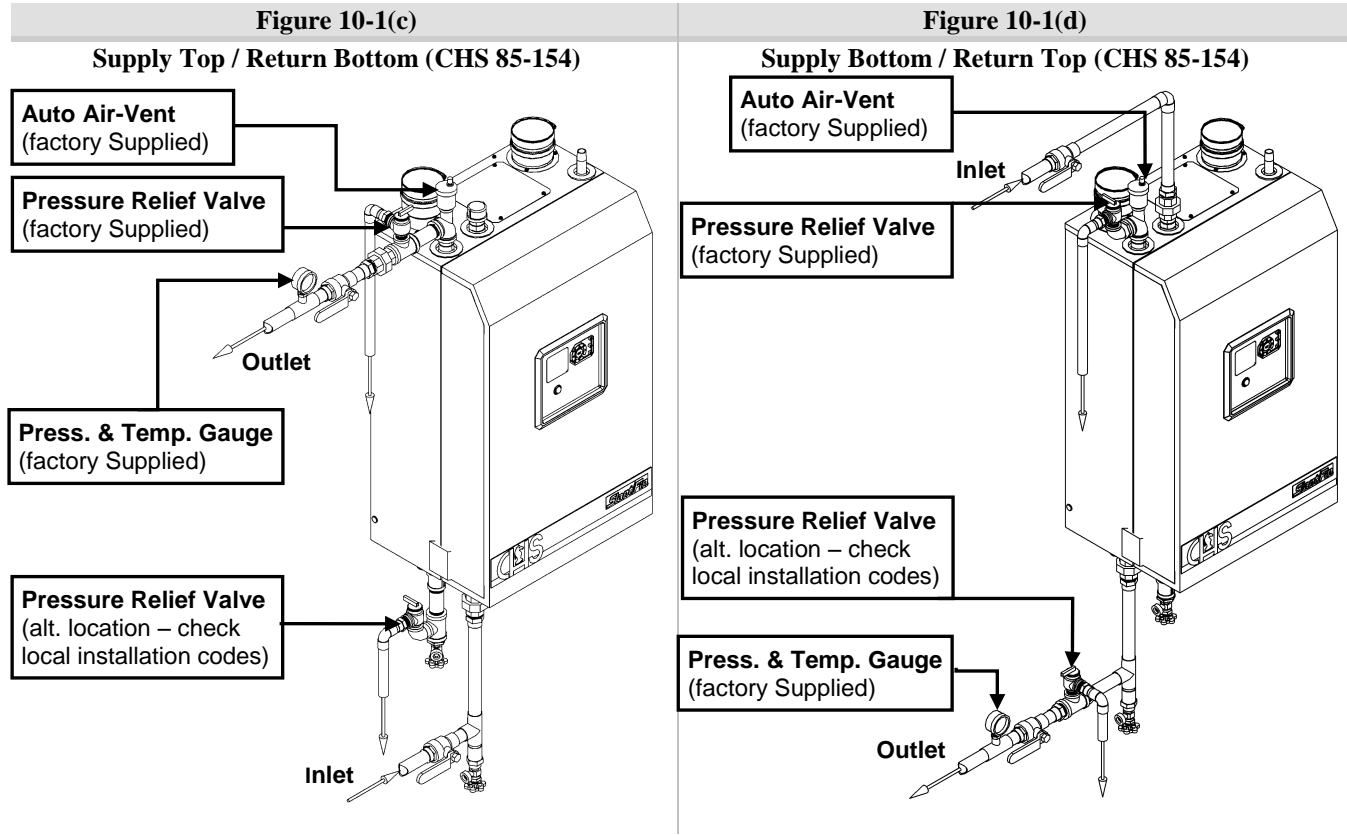

Near Boiler Piping (CHS 201-285)

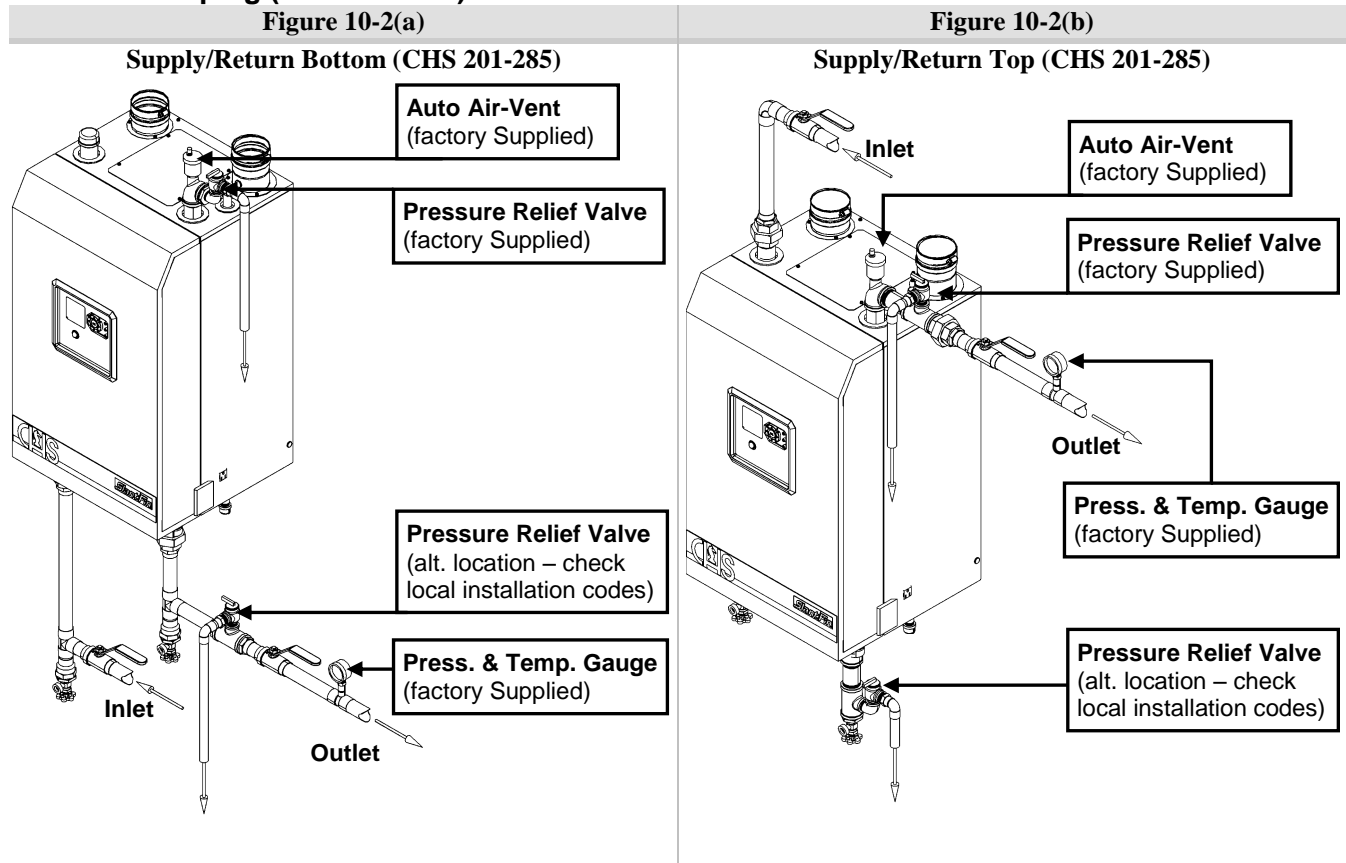

**NOTICE** Boiler Outlet and Inlet water connection location varies between models; reference the applicable figure for correct location.

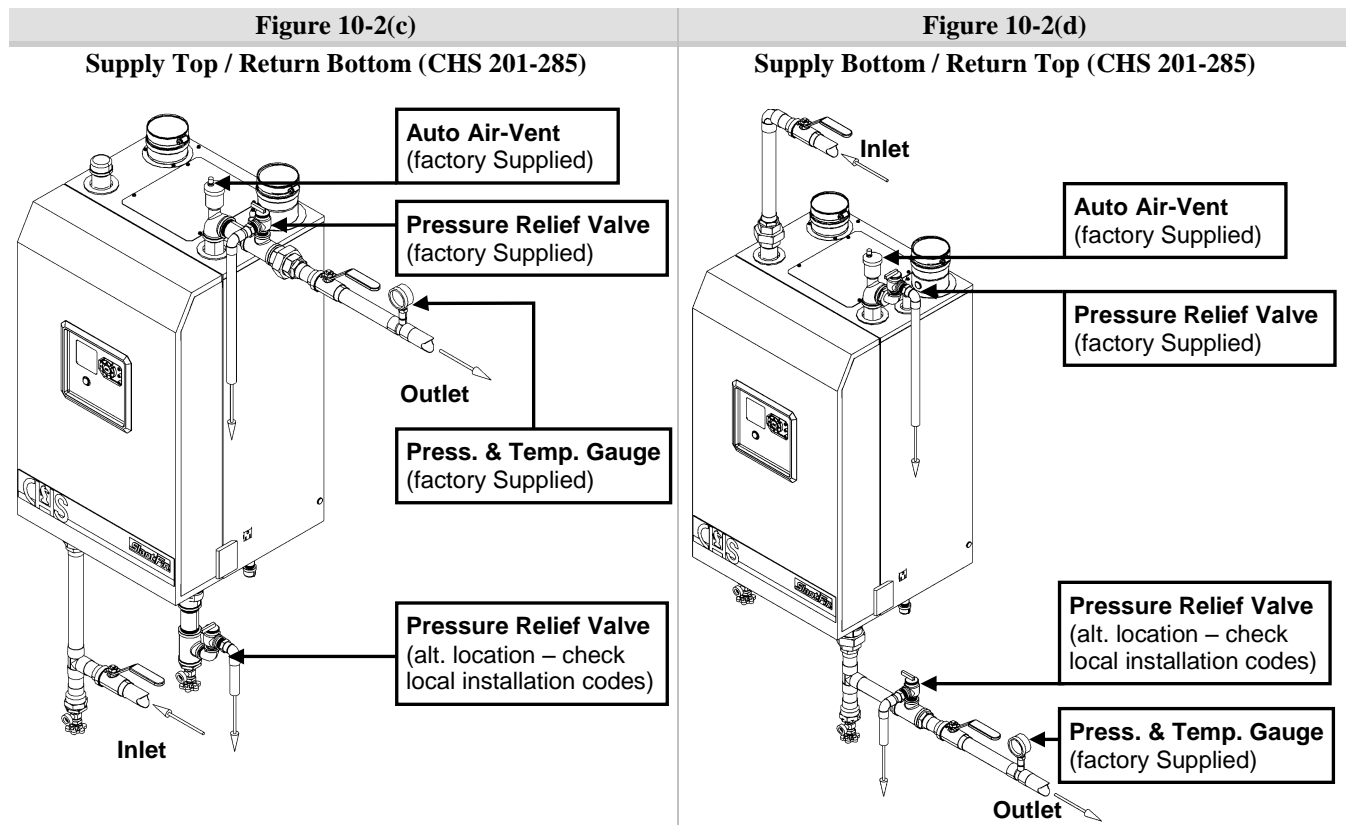

Near Boiler Piping (CHS 340-399)

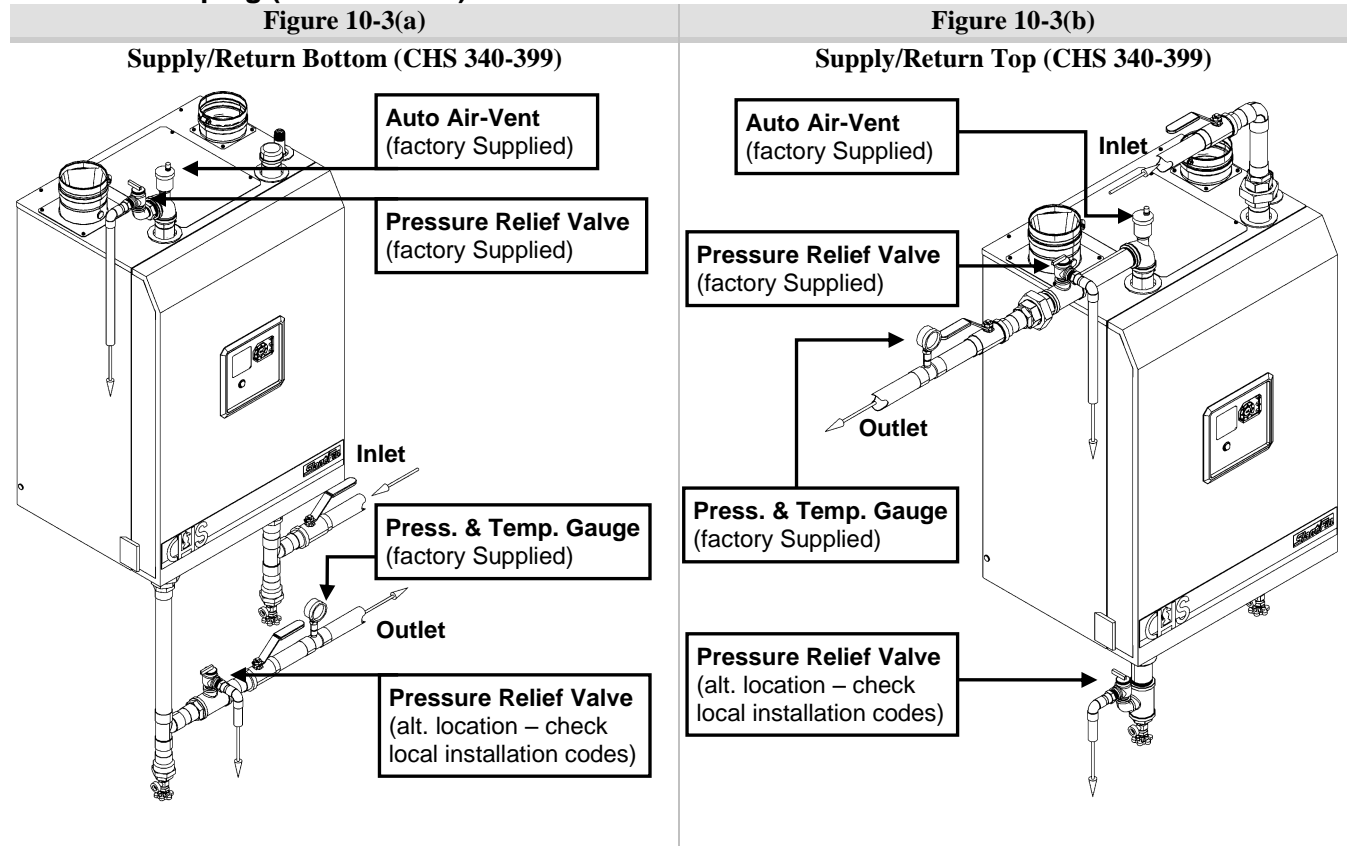

**NOTICE** Boiler Outlet and Inlet water connection location varies between models; reference the applicable figure for correct location.

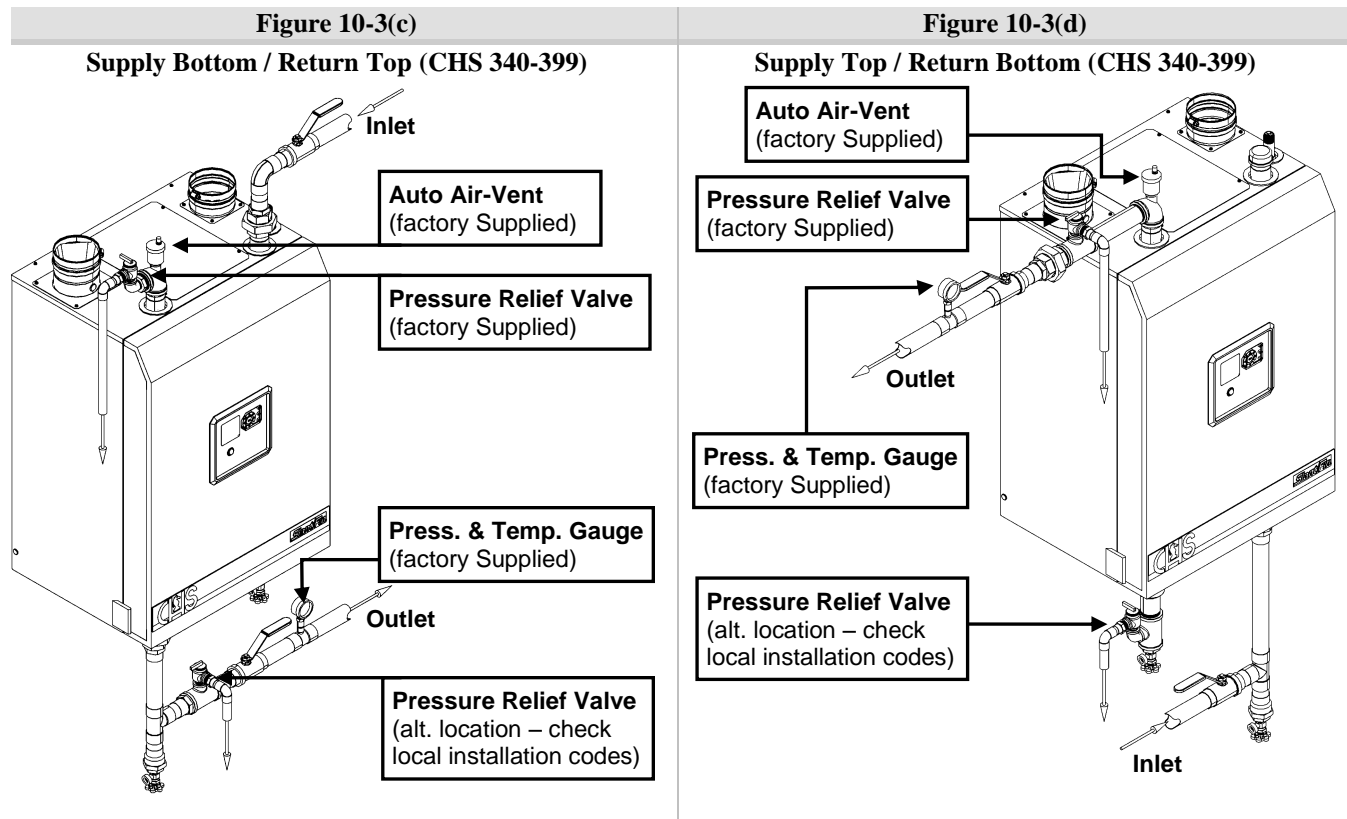

**Boiler System Plumbing**

The CHS boiler uses a low mass heat exchanger that requires a minimum rate of forced water circulation any time the burner is operating (See Table 10-2 for minimum flow rate requirements). To ensure the minimum flow rate is attained, Slant/Fin strongly recommends installing the boiler in a “Primary/Secondary” plumbing configuration utilizing “Closely Spaced Tees” or a “Low Loss Header” to de-couple the Boiler-Primary loop from the System-Secondary loop(s). See the examples of Primary/Secondary Loop configurations in Figures 10-5 and 10-6.

**Table 10-2 Minimum Flow Rate Requirements**

Model	Flow (US gpm)
CHS 85-110	3.5
CHS-154	6.5
CHS-201	7.5
CHS-285	11
CHS-340	13
CHS 399	15

**System Components** – As a minimum, a properly installed system will include the following major components identified in Table 10-3.

**Table 10-3 System Major Component Checklist**

Factory Supplied	Field Supplied Components
<input type="checkbox"/> Pressure Relief Valve	<input type="checkbox"/> Boiler Loop Circulator (Pump B in Figure 10-5 or Pump C in Figure 10-6)
<input type="checkbox"/> Pressure/Temperature Gauge	<input type="checkbox"/> DHW Loop Circulator (Pump A in Figure 10-5 and Figure 10-6, for applications utilizing and Indirect Fired Water Heater)
<input type="checkbox"/> Auto Air Vent	<input type="checkbox"/> Central Heat (CH) Loop Circulator(s) (CH Circulator - Pump C in Figure 10-5; Zone Circulators in Figure 10-6)
	<input type="checkbox"/> Central Air Removal Devices (i.e. Micro Bubbler or Air-Scoop)
	<input type="checkbox"/> Pressure Regulating “Fill Valve”
	<input type="checkbox"/> Backflow Preventer
	<input type="checkbox"/> Expansion Tank

**Circulating Pumps** – CHS boilers are equipped with three 120VAC pump outputs:

1. PUMP A “DHW Pump” - operates during a Domestic Hot Water demand (DHW).
2. PUMP B “Boiler Pump” - operates during any demand.
3. PUMP C “CH Pump” - operates during a Central Heat/Thermostat demand (THERMOSTAT).

Ensure pumps are oriented as per the manufacturers’ instructions. Wiring of these circulators will depend on the system configuration selected; see Figures 10-5 and 10-6. For further wiring details see Section 11.0.

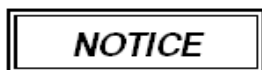

Circulators responsible for forcing the water flow through the boiler must be sized according to Table 10-4. Pump recommendations are based on a Primary/Secondary plumbing configuration (see Figures 10-5 and 10-6) using the listed pipe size in the Boiler-Primary Loop, with up to 50 equivalent feet of pipe length. The installer is responsible for sizing the boiler circulator(s) and piping for applications using non Primary/Secondary plumbing; Figure 10-4 provides Head Loss curves for this purpose.



Failure to ensure the minimum water flow rate through the boiler when the burner is operating will result in “short-cycling”, reduced performance and operating efficiency, and may also cause overheating and premature failure which will void the warranty. Failure to follow instructions may result in fire, property damage, serious injury or death.

Table 10-4 Circulator and Pipe Size Requirements

Model	Temp. Rise (°F)	Boiler Flow Rate (GPM)	Boiler Head Loss (ft)	Minimum Pipe Size	Minimum Primary Loop Pump Size <sup>(1)</sup>			
					B&G	Grundfos	Taco	Armstrong
CHS-85	20	8	3.4	1"	NRF-22	UPS15-58	0015-MS	Astro 30
	25	6	2.7	1"	NRF-22	UPS15-58	0015-MS	Astro 30
	35	4	1.6	3/4"	NRF-22	UPS15-58	0015-MS	Astro 30
CHS-110	20	10	3.9	1" <sup>2</sup>	NRF-22 <sup>2</sup>	UPS15-58	0015-MS	Astro 30 <sup>2</sup>
	25	8	3.4	1"	NRF-22	UPS15-58	0015-MS	Astro 30
	35	6	2.7	1"	NRF-22	UPS15-58	0015-MS	Astro 30
CHS-154	20	14	5.3	1-1/4"	NRF-25	UPS26-99	0015-MS	E7
	25	11	3.9	1-1/4"	NRF-22	UPS15-58	0015-MS	Astro 30
	35	8	3.1	1"	NRF-22	UPS15-58	0015-MS	Astro 30
CHS-201	20	18	7.5	1-1/2"	NRF-36	UPS26-99	0013-MS	E7
	25	15	5.8	1-1/4"	NRF-36	UPS26-99	0013-MS	E7
	35	11	3.9	1-1/4"	NRF-22	UPS15-58	0015-MS	Astro 30
CHS-285	20	26	14	1-1/2"	NRF-36	UPS26-99	0013-MS	E8
	25	21	9.8	1-1/2"	NRF-36	UPS26-99	0013-MS	E7
	35	15	5.7	1-1/4"	NRF-25	UPS26-99	0015-MS	E7
CHS-340	20	32	7.9	2"	NRF-36	UPS26-99	0012-MS	E8
	25	25	8.2	1-1/2"	NRF-36	UPS26-99	0013-MS	E7
	35	18	5.7	1-1/2"	NRF-36	UPS26-99	0013-MS	E7
CHS-399	20	37	8.2	2"	PL55	UPS26-150	2400-60	E11
	25	29	5.7	2"	NRF-36	UPS26-99	0012-MS	E8
	35	21	3.9	1-1/2"	NRF-36	UPS26-99	0013-MS	E7

**Notes:**

<sup>1</sup> Pump sizing based on Primary/Secondary plumbing configuration with specified minimum pipe diameter with up to 50' equivalent length.

<sup>2</sup> Upsize piping to 1-1/4" if using Armstrong Astro 30 or B&G NRF-22; alternatively upsize circulator to Astro 50 or NRF-25.

Figure 10-4(a) CHS 85-110 Head Loss Curve

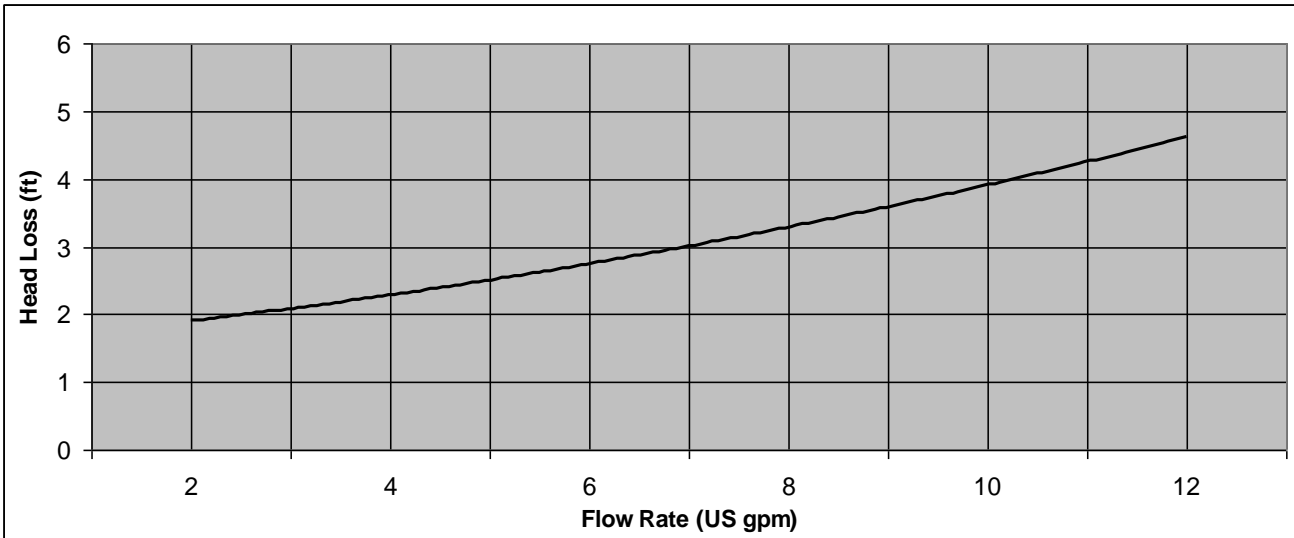

Figure 10-4(b) CHS 154-285 Head Loss Curve

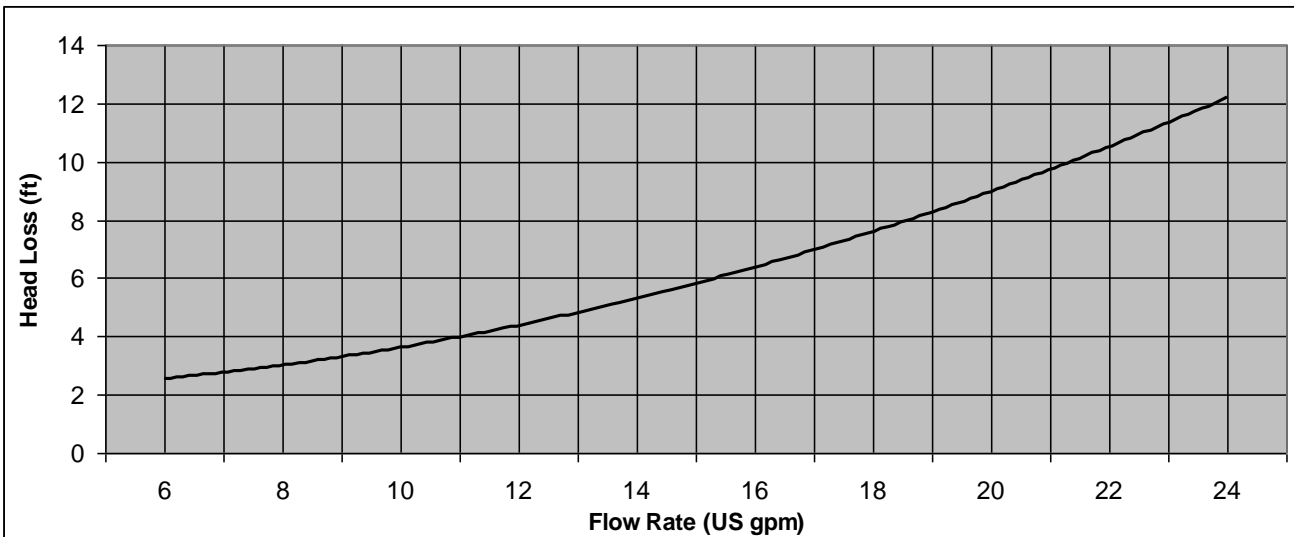
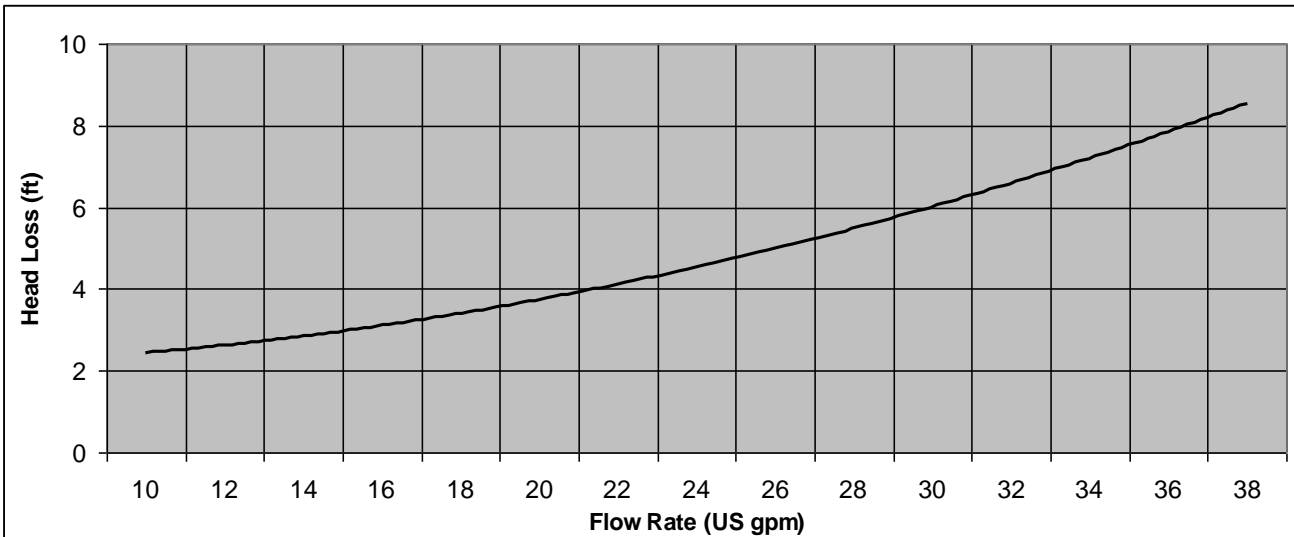

Figure 10-4(c) CHS 340-399 Head Loss Curve



**Air Removal** – The boiler and system plumbing layout must be configured to promote the removal of air from the water. Air vents and bleeders must be strategically placed throughout the system to aid in purging the air from the system during commissioning of the boiler. The system must also employ the use of a strategically located air removal device, such as an air scoop or micro-bubbler, designed to remove the air from the water as it flows through the system.

**NOTICE**

Follow the installation instructions included with the air removal device when placing it in the system; air removal devices generally work better when placed higher in the system. Always locate air removal devices in areas of the system that have a guaranteed positive pressure, e.g., in close proximity to the water fill and expansion tank.

**NOTICE**

CHS boilers are supplied with an automatic air removal device to aid in the purging of air from the boiler during the initial fill. Place this device in the location indicated in Figures 10-1 through 10-3.

**Expansion Tank** – The expansion tank must be sized in accordance with the water volume of the system as well as the firing rate of the appliance. It is important to locate the expansion tank, and make-up water fill, on the inlet side of any circulator in the system, as doing so will guarantee the lowest pressure in the system will be at least equal to the tank and make-up water pressure. See examples in Figures 10-5 and 10-6.

**CAUTION**

Ensure the expansion tank cannot become isolated from the boiler anytime the system is operating. Failure to follow these instructions may result in discharge of the Pressure Relief Valve may result in property damage or personal injury.

**NOTICE**

The installation of flow checks, motorized valves or other shutoff devices (other than for the purpose of servicing) are not permitted between the location of the "Closely Spaced Tees" and the expansion tank; see Figures 10-5 and 10-6.

**Indirect Fired Water Heater** – When installed as per Figure 10-6, the indirect fired water heater is in series with the boiler during a demand for DHW. Therefore, its head loss, along with the head loss of the boiler and associated piping, must be considered when sizing the circulator.

**Figure 10-5: Single System Circulator Configuration** - Often used in applications zoned with "Zone Valves". During a demand for central heat, the boiler energizes the System Circulator via the Central Heating (CH) pump output (PUMP C). The System Circulator must be sized to provide adequate circulation throughout the heating system. During a Domestic Hot Water (DHW) demand, the boiler de-energizes the System Circulator (PUMP C) and energizes the DHW Circulator (Pump A). With this configuration the Boiler Circulator is the only pump that causes flow through the boiler and it is powered during any demand via the boiler pump output (PUMP B). This circulator must be sized according to Table 10-4.

**NOTICE**

The piping configuration described above requires the Central Heating system and DHW system to be de-coupled from the "Primary Loop" via closely spaced tees (Figure 10-5).

**Figure 10-6: Multiple System Circulator Configuration** - Often used in applications with "Zone Circulators". This configuration requires the installation of a check valve located at each circulator. During a central heating demand the boiler energizes the Central Heat Circulator via the Central Heat pump output (PUMP C). During a Domestic Hot Water (DHW) demand, the boiler de-energizes PUMP C and energizes the DHW Circulator (Pump A). Both Pump A and C, used in this configuration, are responsible for water flow through the boiler and must be sized according to Table 10-4. Pump output, PUMP B is not used in this configuration.

**NOTICE**

Figures 10-5 and 10-6 illustrate typical piping systems. These piping schematics do not illustrate all of the required concepts and components required to have a proper installation. Concepts not shown include: prevention of thermal-siphoning (heat traps), isolation valves, drain and purge valves, etc. It is the responsibility of the installing contractor and system designer to determine which system best meets the need of the installation and to consider all aspects of a proper system design. Contractor modifications to these instructions may be required, based upon existing piping and system design.

Figure 10-5 Primary/Secondary Plumbing  
(Single System Circulator Configuration)

**NOTICE**

Water connection locations will vary between boiler models; refer to Figures 10-1 to 10-3.

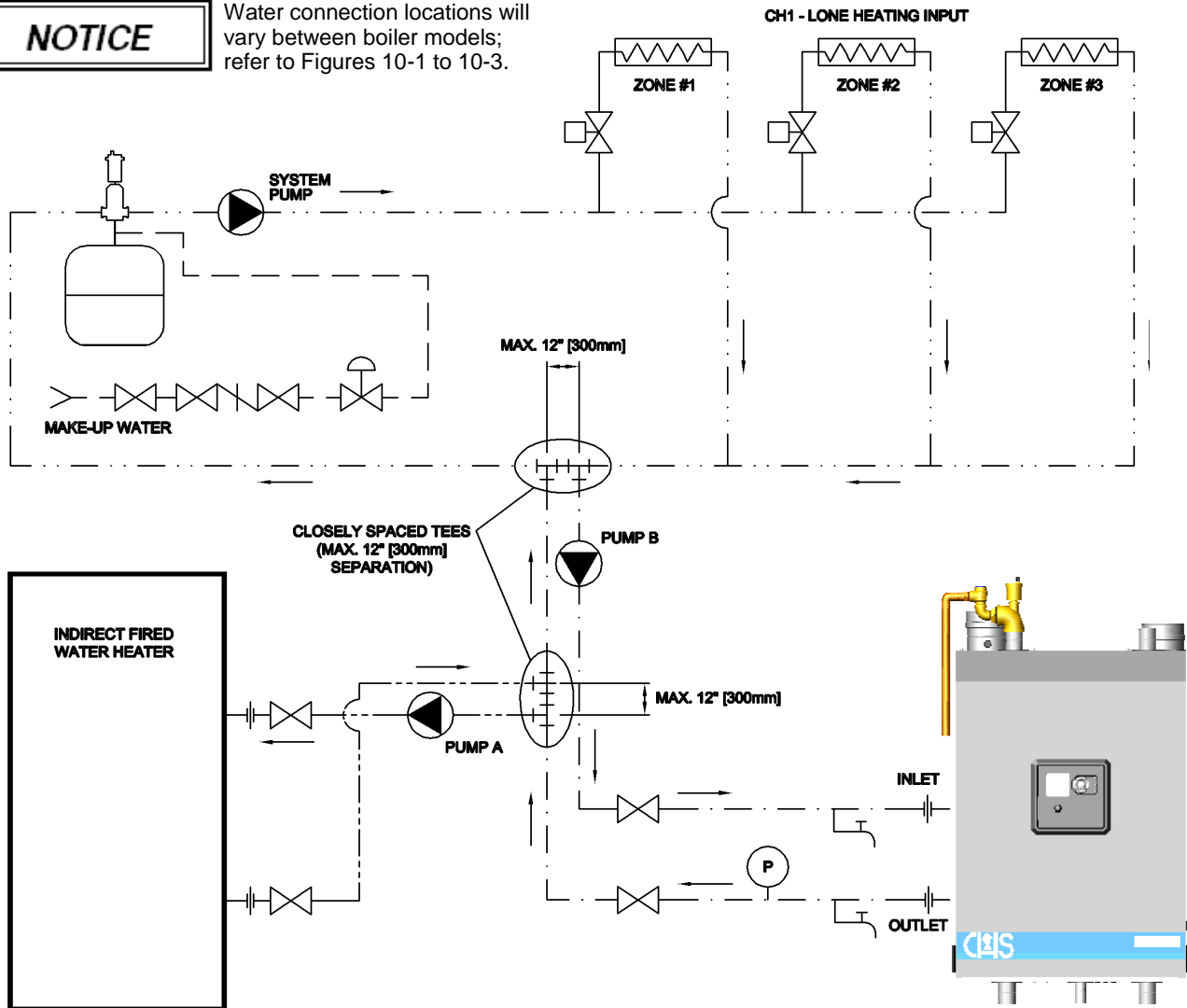

LEGEND

SYMBOL	DESCRIPTION	SYMBOL	DESCRIPTION	SYMBOL	DESCRIPTION
---	MAKE-UP WATER		BACKFLOW PREVENTOR		AIR SEPARATOR
---	PRIMARY LOOP		PRESSURE RELIEF VALVE		PUMP
---	CENTRAL HEATING SECONDARY LOOP		PRESSURE REGULATING VALVE		UNION
---	DHW SECONDARY LOOP		DRAIN VALVE		TEE
	ISOLATION VALVE		AIR VENT		FLOW DIRECTION
	ZONE VALVE		EXPANSION TANK		PRESSURE GAUGE
	ZONE LOAD				



Figure 10-6 Primary/Secondary Plumbing  
(Multiple System Circulator Configuration)

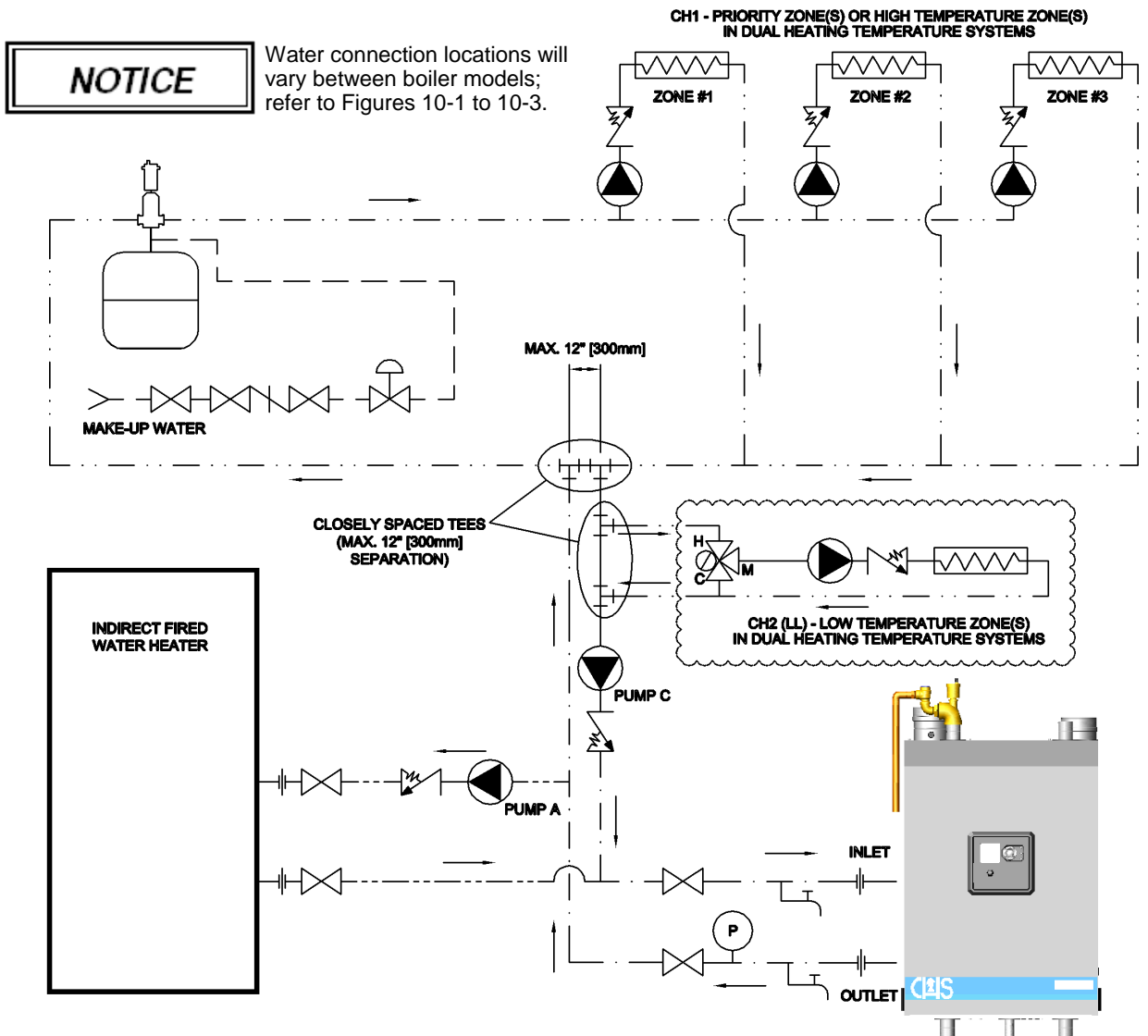

LEGEND

SYMBOL	DESCRIPTION	SYMBOL	DESCRIPTION	SYMBOL	DESCRIPTION
---	MAKE-UP WATER		BACKFLOW PREVENTOR		AIR SEPARATOR
---	PRIMARY LOOP		PRESSURE RELIEF VALVE		PUMP
---	CENTRAL HEATING SECONDARY LOOP		PRESSURE REGULATING VALVE		UNION
---	DHW SECONDARY LOOP		DRAIN VALVE		TEE
	ISOLATION VALVE		AIR VENT		FLOW DIRECTION
	ZONE VALVE		EXPANSION TANK		SPRING CHECK VALVE
	ZONE LOAD		PRESSURE GAUGE		OPTIONAL
	THERMOSTATIC MIXING VALVE				

**Multiple Boiler Applications**

The CHS controller has the internal capacity to stage or Lead-Lag up to 8 boilers configured in a cascade. This Lead-Lag capability allows a designated “Master” boiler to communicate with and effectively control each boiler in a multiple boiler system. This function is accomplished by “Daisy Chaining” a 3-wire cable between each of the boilers and enabling the Master parameter in the boiler of your choice. The boiler with the Master parameter enabled becomes the single point of contact for Central Heating and Outdoor Reset set-points as well as system control wiring such as the Thermostat demand and Outdoor and System Water Temperature. See section on Low Voltage Connections for wiring and control set-up details. Figures 10-7 and 10-8 are examples of multiple boiler plumbing configurations illustrating small and large DHW applications.



**Modbus Address** – Each boiler in a cascade arrangement (lead-lag) must have a unique modbus address between 1 and 8, inclusive. For detailed instructions on how to set the modbus address for each CHS controller, refer to "System ID & Access" in Appendix A.

**Figure 10-7: Multiple Boiler Applications with Small DHW Requirements** – Used in applications where the DHW load can be satisfied by a single boiler. In this example, Boiler 1 provides DHW priority over Central Heating, while Boilers 2 and 3 provide Central Heating only; furthermore, the DHW demand to Boiler 1 comes directly from the Aquastat of the Indirect Fired Water Heater.

**Figure 10-8: Multiple Boiler Applications with Large DHW Requirements** – Used in applications where the DHW load is too large to be satisfied by a single boiler. In this example, Boilers 1 and 2 provide DHW priority over Central Heating, while Boiler 3 provides Central Heating only. In contrast to small DHW requirements, the Aquastat(s) of the Indirect Water Heater(s) is used to activate the main DHW pump and a relay is used to trigger individual contacts for the DHW inputs of Boilers 1 and 2. Refer to Figure 11-3 for relay wiring details.

During a Lead-Lag Central Heat demand [CH2 (LL)], the Master communicates the call to the applicable boiler(s); boilers attempting to satisfy the Central Heat demand will energize their local pump contacts B (Boiler) and C (Central Heat). Boilers not responsible for heating DHW use pump contact B for controlling their local Central Heat Pump (see Boilers 2 and 3 in Figure 10-7). Boilers responsible for heating DHW use pump contact C for controlling the local Central Heat Pump (see Boilers 1 and 2 in Figure 10-8). A boiler receiving a local DHW demand will turn off pump contact C for Central Heat and will activate pump contact A for DHW, thus providing DHW priority.

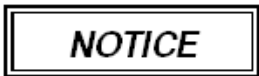

With the exception of the Main System circulator in Figures 10-7 and 10-8 and the Main DHW circulator in Figure 10-8, all circulators must be sized to support adequate water flow through the boiler.

**System Circulator** - The installer can designate one of the boilers, preferably one not responsible for DHW heating, to control the operation of the System Circulator. Via the user interface, under “Pump Configuration” and “Central Heat Pump”, check the box labeled “Use for Lead Lag Master demand”. This forces the local pump output C to activate when the Master gets a Lead-Lag Central Heat demand [(CH2 (LL))]. Pump output C can then be used to power the System Circulator. Due to the large load of a typical system circulator, it is recommended that a 120VAC isolation relay be used instead of powering the system circulator directly from pump output C (i.e. pump output C is limited to 3 Amps or 1/6hp).

**Table 10-5 Minimum Pipe Sizes for Multiple Boiler Applications**

# of Units	CHS-85	CHS-110	CHS-155	CHS-175	CHS-201	CHS-285	CHS-340	CHS-399
	Pipe Size							
2	1-1/4"	1-1/2"	1-1/2"	2"	2"	2"	2-1/2"	2-1/2"
3	1-1/2"	2"	2"	2"	2-1/2"	2-1/2"	3"	3"
4	2"	2"	2-1/2"	2-1/2"	2-1/2"	3"	3"	3"
5	2"	2-1/2"	2-1/2"	3"	3"	4"	4"	4"
6	2"	2-1/2"	3"	3"	4"	4"	4"	5"
7	2-1/2"	2-1/2"	3"	4"	4"	4"	5"	5"
8	2-1/2"	3"	3"	4"	4"	4"	5"	5"

Note: Minimum pipe size based on assumed temperature rise of 25°F at maximum firing rate.

Figure 10-7 Multiple Boiler Lead-Lag Plumbing Configuration  
(Small DHW Requirements)

LEGEND			
SYMBOL	DESCRIPTION	SYMBOL	DESCRIPTION
---	MAKE-UP WATER	⊓	BACKFLOW PREVENTOR
---	PRIMARY LOOP	⊕	PUMP
---	CENTRAL HEATING SECONDARY LOOP	⊖	PRESSURE RELIEF VALVE
---	DHW SECONDARY LOOP	⊖	PRESSURE REGULATING VALVE
⊗	ISOLATION VALVE	⊕	DRAIN VALVE
⊗	ZONE VALVE	⊕	AIR VENT
⊗	ZONE LOAD	⊕	EXPANSION TANK
⊗		⊕	PRESSURE GAUGE
⊗		⊕	SYSTEM SENSOR

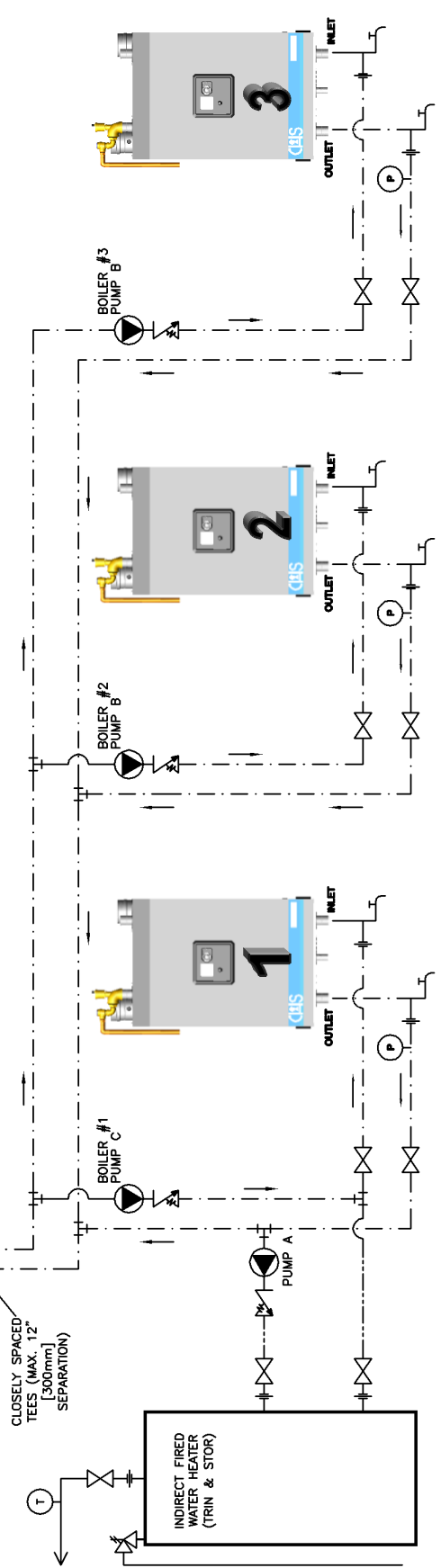
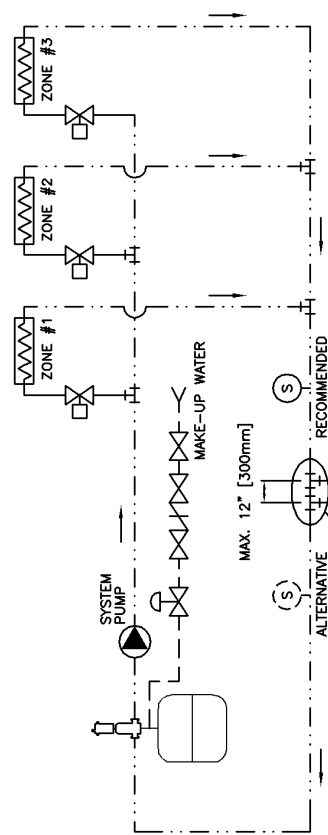

**NOTICE**

Water connection locations will vary between boiler models; refer to Figures 10-1 to 10-3.

Figure 10-8 Multiple Boiler Lead-Lag Plumbing Configuration  
(Large DHW Requirements)

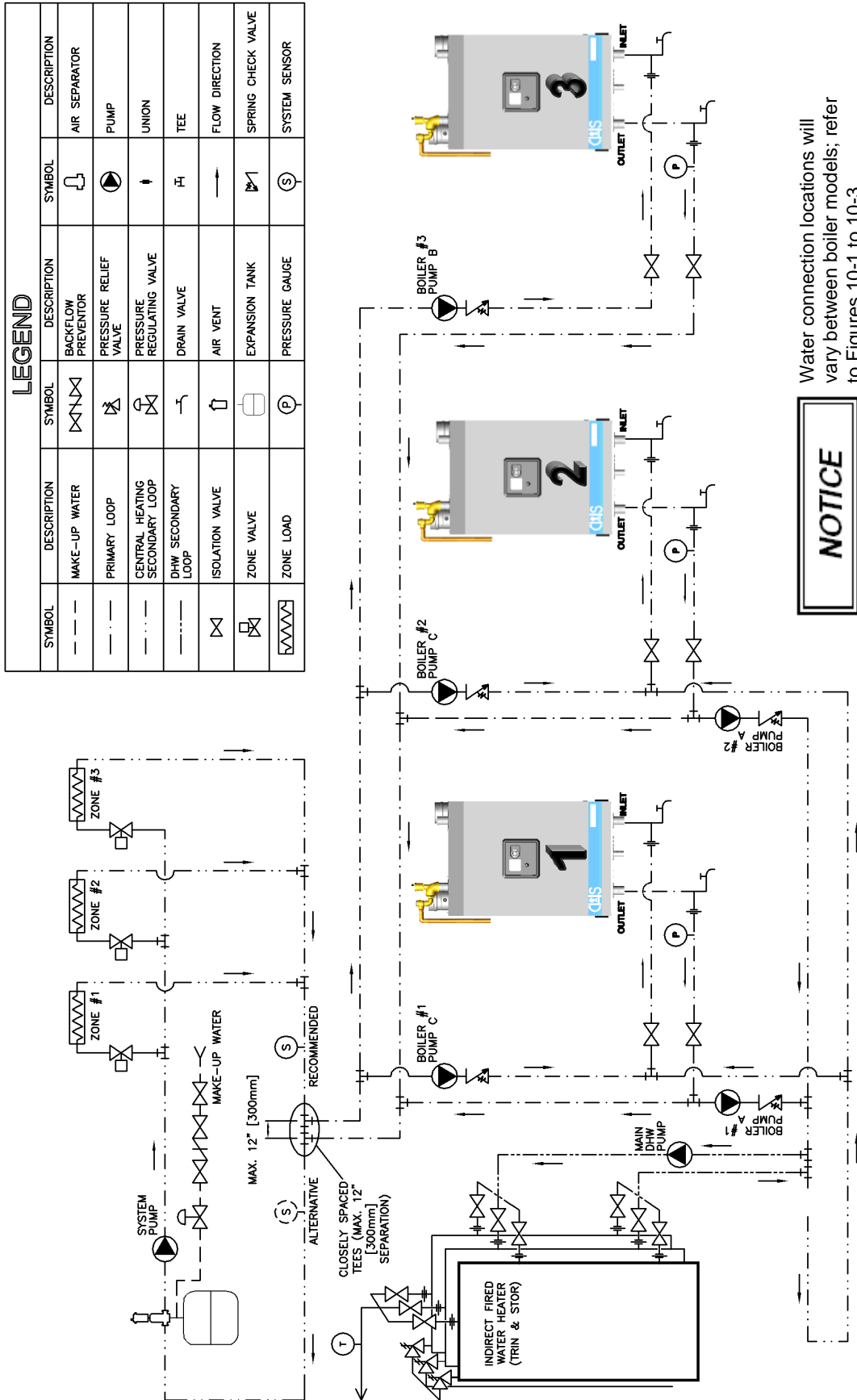

## 11.0 FIELD WIRING

All wiring must be in accordance with the Canadian Electrical code, CSA C22.2 and any applicable local codes. Ensure that the wiring complies with this manual. The boiler must be electrically grounded in accordance with the National Electrical Code ANSI/NFPA 70, local codes, and/or the Canadian Electrical Code CSA C22.1.



**Avoid Shocks** - To Avoid Electrical Shock, turn off electrical power to the boiler prior to opening any electrical box within the unit. Ensure the power remains off while any wiring connections are being made. Failure to follow these instructions may result in component failure, serious injury or death.

**Field Wiring** - Wire grommets must be used to secure wiring and prevent chafing when passing wiring through the cabinet wall. Failure to follow instructions may damage unit.

### Line Voltage Connections

Electrical rating for the CHS boiler is 120V/1 Phase/60 Hz/12A. All line voltage wiring connections to the CHS are made at the junction box in the control panel located at the bottom of the boiler cabinet. The connections are accessed by removing the front door of the boiler, followed by the removal of the control panel cover. Field connections are to be installed in accordance with Figure 11-1 and Table 11-1. Holes are located on the bottom (underside) of the control panel junction box.

**Fuses (120VAC)** – The CHS boiler is equipped with two 7 Amp fuses to protect 120VAC system components. The fast-acting fuses are located on the left side of the control panel and are easily accessed upon removal of the front cover of the boiler cabinet.

- Fuse A: Protects the blower, spark generator and PUMP B output circuits.
- Fuse B: Protects PUMP A and PUMP C output circuits.



**Wire Protection** - When passing any wiring through the cabinet of the boiler, the installer must use wire grommets suitable for securing the wiring and preventing chafing. Failure to follow instructions may result in component failure, serious injury or death.



**Power Supply** - The CHS boiler is designed to be powered using a single phase 120VAC power supply that is fused (or protected via a circuit breaker) to allow a maximum of 15 Amps. Failure to follow instructions may result in component failure, serious injury or death.

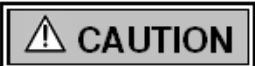

**Labeling** - Label all wires prior to disconnecting them when servicing controls. Wiring errors can cause improper and dangerous operation. Failure to follow instructions may result in property damage or personal injury.

**Continuity** - Before connecting the line voltage wiring, perform a continuity check between all wires and ground to make sure that there are no electrical leaks that could blow a fuse or damage electrical components. Also check the polarity of the line and neutral wires. Line must measure 120VAC to ground; neutral must measure zero. Failure to follow instructions may damage the unit.

**Max Load** - Circulator outputs (PUMP A, B, C) are each limited to operating a circulator with a maximum current load of 3 Amps or a maximum 1/6 hp motor. See Table 11-1.

Figure 11-1 Line Voltage Field Wiring

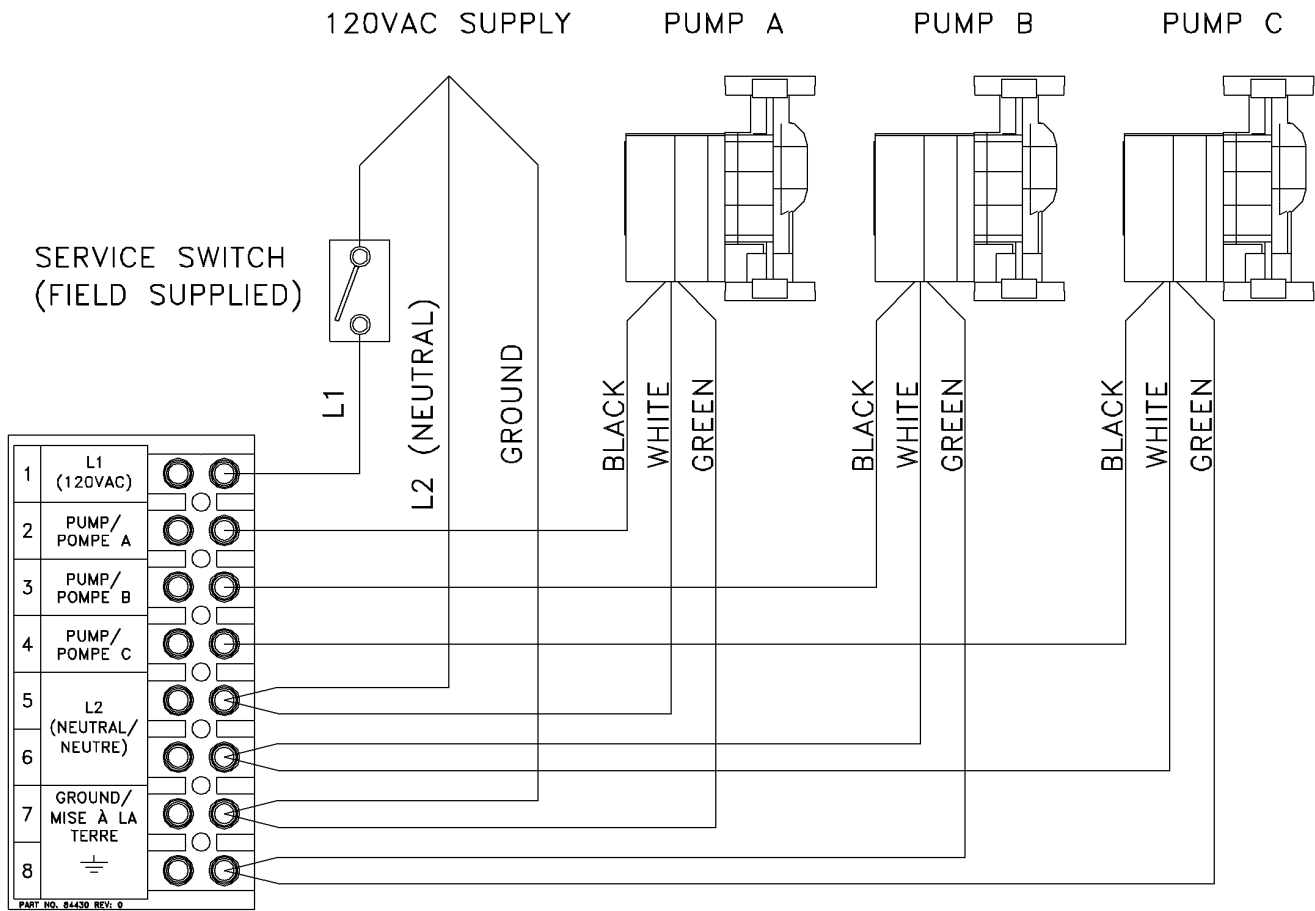

Table 11-1 Line Voltage Field Connections

Connection	Location	Description
L1 (120VAC)	1	Location for connecting line voltage of the power supply. Note; most installation codes require the installation of a service switch to break line voltage to the appliance.
PUMP A	2	120VAC output to the DHW circulator; powered during a demand for DHW.
PUMP B	3	120VAC output to the Boiler circulator; powered during all demands; DHW, local Central Heat (CH1) and Lead-Lag Central Heat [CH2 (LL)]. This output is not used for all plumbing configurations, see Section 10.0.
PUMP C	4	120VAC output to the Central Heating circulator; powered during a demand for local Central Heat (CH1) or Lead-Lag Central Heat [CH2 (LL)].
L2 (Neutral)	5	Location for connecting neutral of the power supply and all circulators.
	6	
Ground	7	Location for connecting earth ground and for grounding all of the circulators.
	8	

**Low Voltage Connections**

Like the line voltage, the low voltage wiring connections to the CHS boiler are made at the junction box in the control panel located at the bottom of the boiler cabinet. The connections are accessed by removing the front door of the boiler, followed by the removal of the control panel cover. Field connections are to be installed in accordance with Figure 11-2 and Tables 11-2a and 11-2b. Holes are located on the bottom (underside) of the control panel junction box.

**NOTICE**

**Fuse (24VAC)** - CHS models are equipped with a “blade style” 2 Amp fuse to protect the internal transformer located within the control panel box.

**Table 11-2a Low Voltage Field Connections (Communication and Sensor I/O)**

Connection		Location	Description
COMM.	DATA +	1	<b>Lead-Lag</b> – Terminals 1, 2 and 3 can be "daisy-chained" to multiple boilers (up to 8 total) for the purpose of staging. For lone boiler applications, these terminals can be alternatively used for communication to an external device (i.e. Building Automation System, BAS)
	DATA -	2	
	DATA COM	3	
4-20mA (+)		4	<b>External Modulation Control</b> – Using a 4-20mA signal connected to terminals 4 and 5, an external control can be used to directly modulate the burner firing rate or adjust the active set point. This can be useful for applications using external staging controls or Building Automation Systems.
4-20mA (-)		5	
SENSOR	COM	6	<b>Sensor Common</b> – Common port for field inputs SYSTEM, OUTDOOR and DHW.
	SYSTEM	7	<b>System Water Temperature</b> – An optional strap-on System Sensor is available from Slant/Fin (P/N 81 8146 000). When connected to terminals 6 and 7, the control will indicate a “CH” or “Lead-Lag” temperature. Sensor can be used for direct modulation of system temperature.
	OUTDOOR	8	<b>Outdoor Temperature Sensor</b> – A wall mountable OD Sensor is included with each boiler. When connected to terminals 6 and 8, the control will indicate the outdoor temperature and Outdoor Reset function will be operable.
	DHW	9	<b>DHW Tank Demand</b> – Input requiring closure of terminals 6 and 9 to initiate a demand for DHW. Switch made via isolated end switch (dry contact) from a thermostat (aquastat) located in an Indirect Fired Water Heater. Optional DHW Tank Sensor see Appendix A for details.

**Table 11-2b Low Voltage Field Connections (24VAC I/O)**

Connection		Location	Description
COM (24VAC)		1	<b>24VAC Common</b> – Neutral for the 24VAC power supply from the boiler. COM can be used in conjunction with terminal R to provide a power source for a digital thermostat.
R (24VAC)		2	<b>24VAC Hot</b> - Power supply for inputs LIM, CH1 and CH2 (LL).
		3	
LIM		4	<b>External Limit</b> – Input requiring 24VAC from terminal R to permit the burner to operate. Comes factory equipped with a jumper to the R terminal. For installations requiring the use of an additional safety switch, such as a Flow Switch, or auxiliary temperature limit, remove the factory installed jumper and install the normally open isolated contacts of the additional limit in its place.
CH1		5	<b>Local Central Heat Demand</b> – Input requiring 24VAC from terminal R to initiate a “local” CH call. Switch is made using an isolated end switch (dry contact) via thermostat, zone controller or other device. Typically used as the lone heat input or as the high temperature input in dual CH temperature systems.
CH2 (LL)		6	<b>Lead-Lag Central Heat Demand</b> – Input requiring 24VAC from terminal R to initiate a “lead-lag” CH call. Switch is made using an isolated end switch (dry contact) via thermostat, zone controller or other device. Typically used as a lead-lag input for cascaded boilers or as the low temperature input in dual CH temperature systems.
ALARM		7	<b>Normally Open Alarm Contacts</b> – Contacts close during a lockout or other alarm condition. May be connected to a BMS, maximum capacity of 0.63Amps at 24VAC.
		8	

**CAUTION**

**Low Voltage Terminals** – “R” terminals 2 and 3 of the 24VAC I/O barrier has 24VAC potential from the internal transformer. Do not connect power from this terminal to any other terminal other than terminals 4, 5 and 6 (LIM, CH1 and CH2 (LL)). Failure to follow these instructions may damage the unit.

**NOTICE**

The low voltage connections are divided into two separate barrier strips: Communication and Sensor I/O (Input/Output) and 24VAC I/O. **DO NOT** connect 24VAC (or other power supply) to the Communication and Sensor I/O connections; doing so will cause control failure.

Figure 11-2 Low Voltage Field Wiring

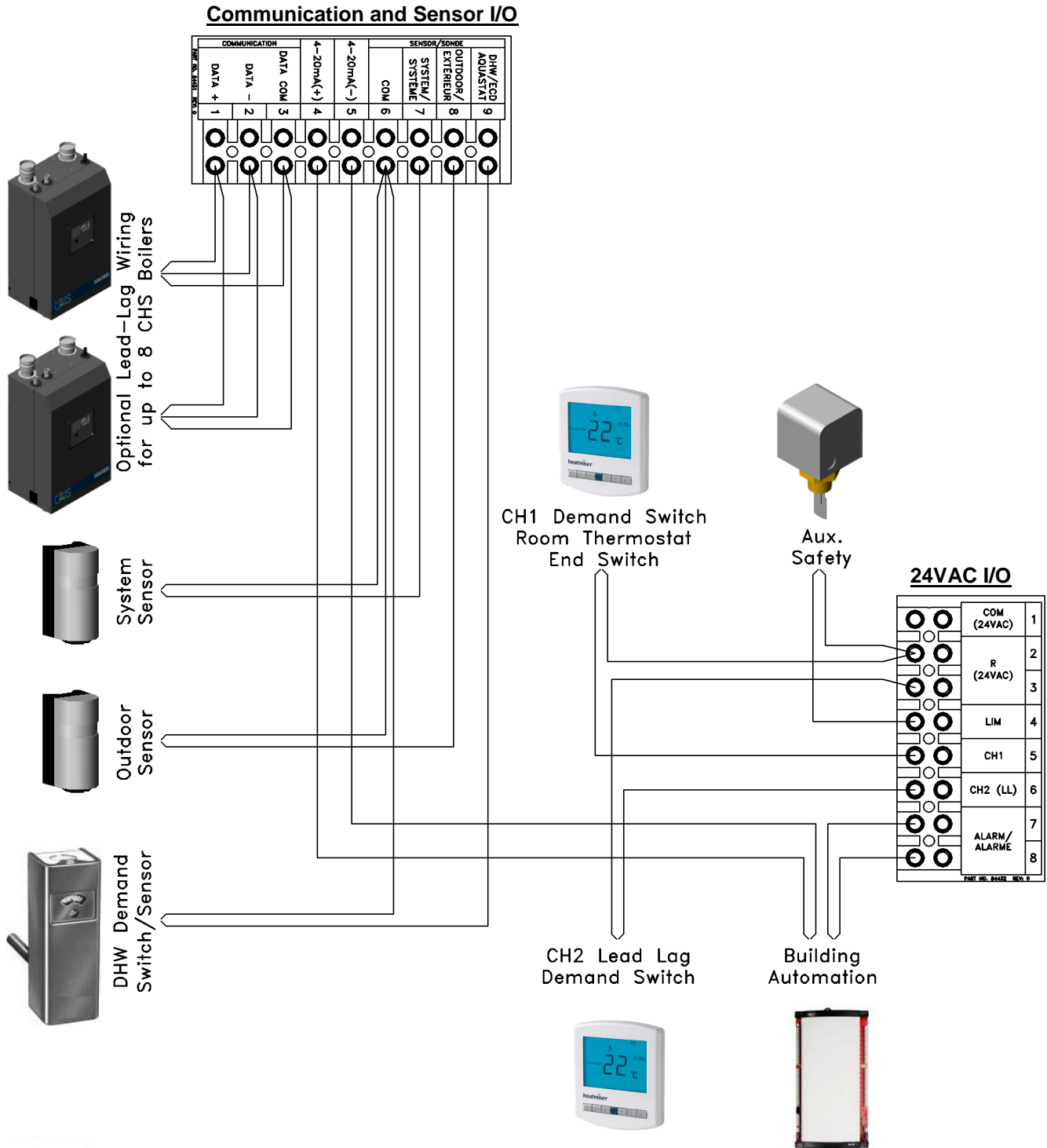
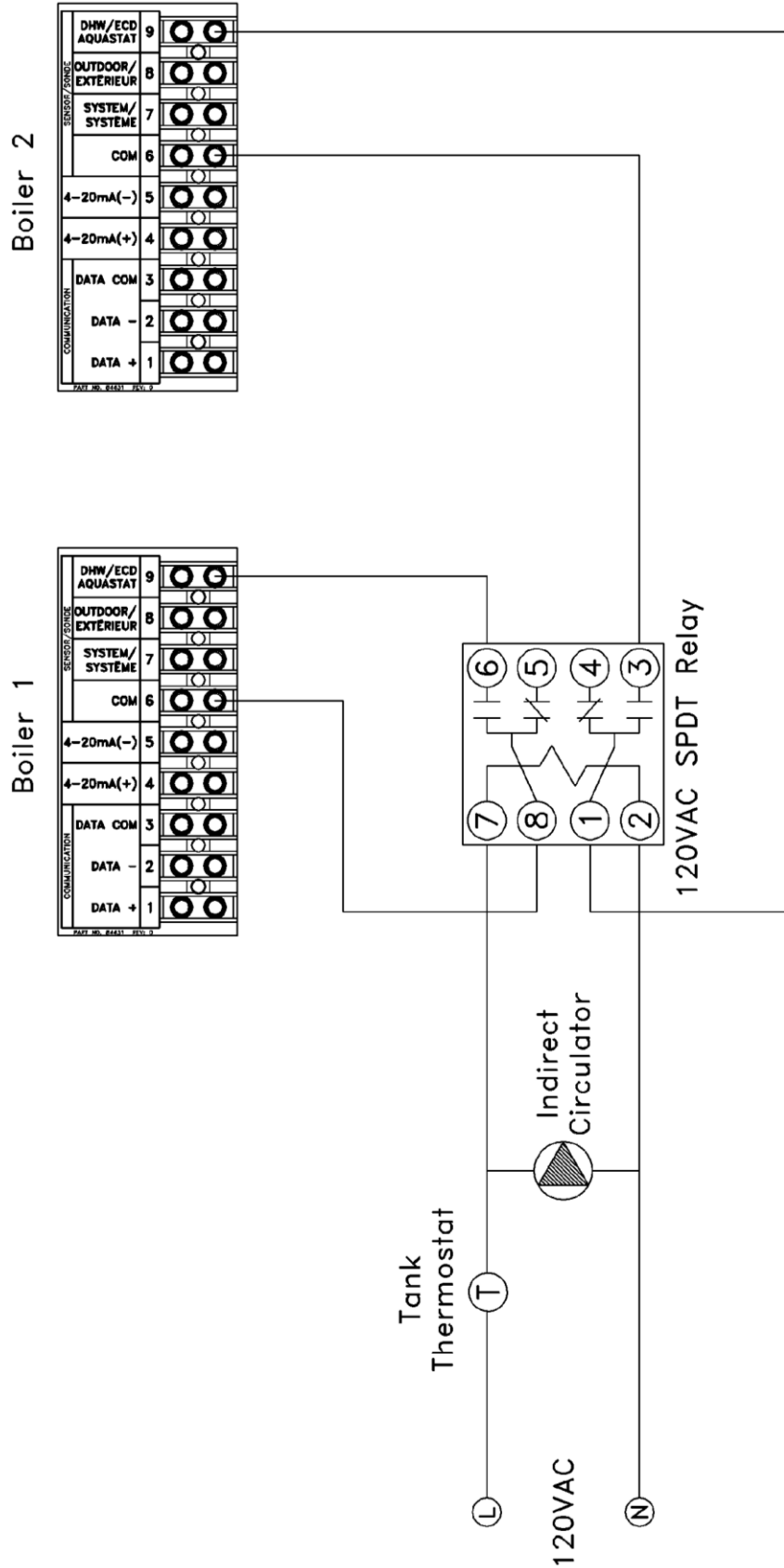

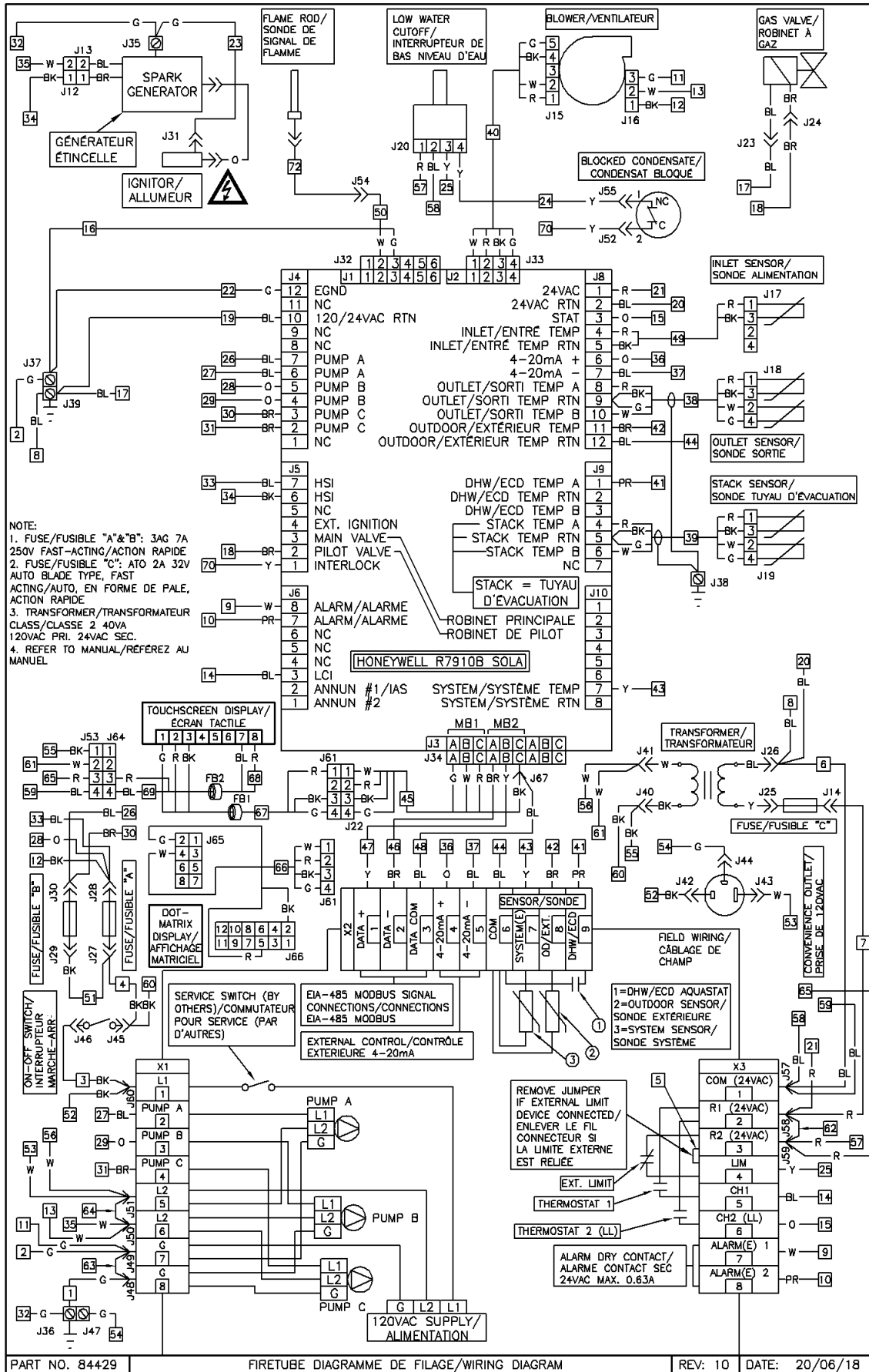

Figure 11-3 DHW Input Contacts (Multiple Boilers)



12.0 WIRING SCHEMATICS

Figure 12-1 CHS Connection Diagram



PART NO. 84429

FIRETUBE DIAGRAMME DE FILAGE/WIRING DIAGRAM

REV: 10

DATE: 20/06/18

Figure 12-2 CHS Ladder/Logic Diagram

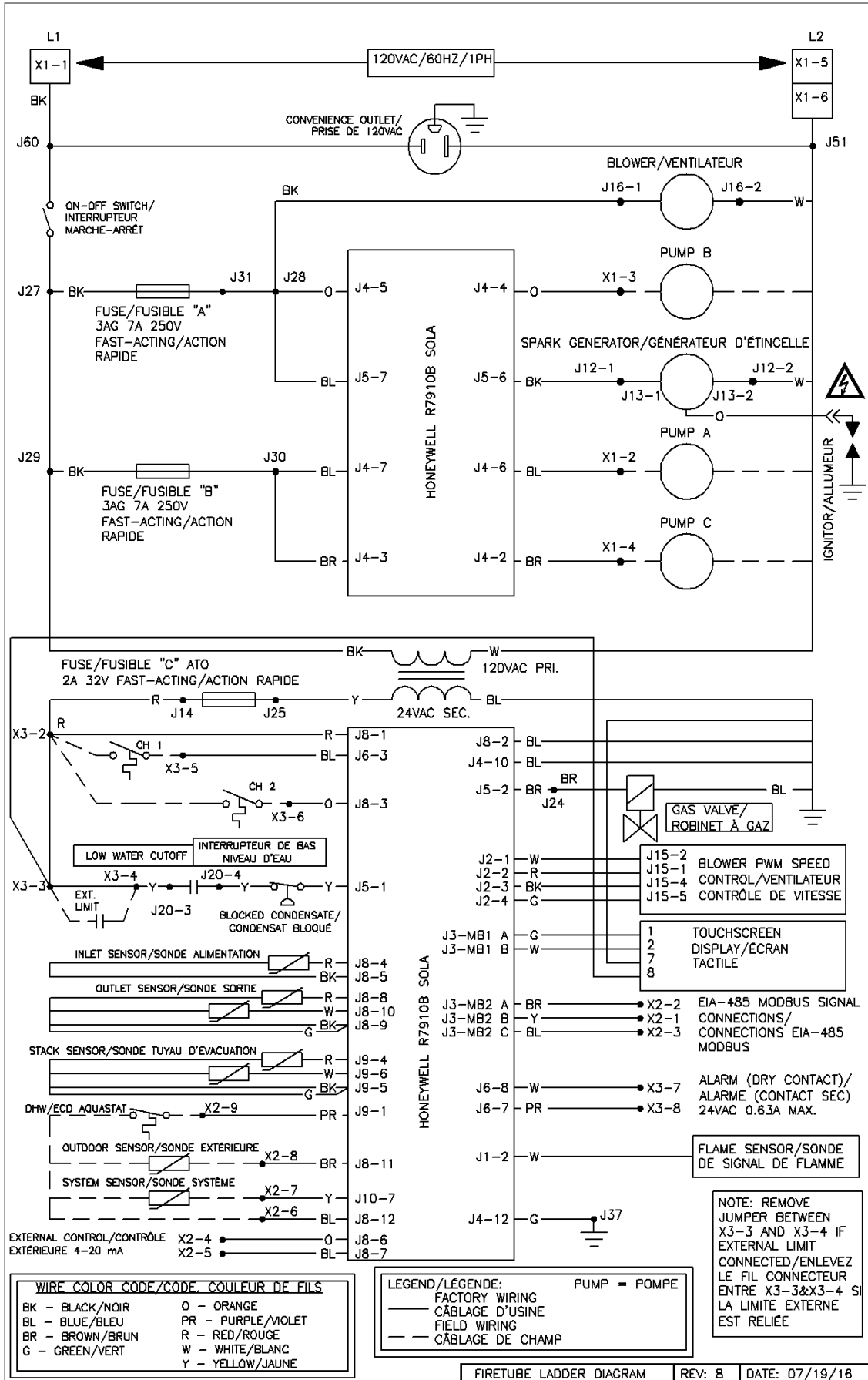

**13.0 INSTALLATION CHECKLIST****Installation**

- 1. If operating on Propane Gas, convert boiler using appropriate *Natural to LP Conversion Instructions*; see Table 7-1.
- 2. Locate the boiler in accordance with Section 3.0 of this manual.
- 3. Install the Vent/Air-inlet piping in accordance with Sections 4.0 and 5.0 of this manual. Ensure all joints are secured and cemented properly. Both the Vent and Air-inlet pipes must terminate outdoors. Perform the **Mandatory Pre-commissioning Procedure for Plastic Venting** in Section 4.0.
- 4. Connect the condensate trap and drain in accordance with Section 6.0 of this manual.
- 5. Connect the gas supply in accordance with Section 7.0 of this manual.
- 6. Install the plumbing in accordance with this manual; flush/cleanse the internals of the heating system. Treat system water with Fernox F1 Protector when needed.
- 7. Connect field wiring in accordance with Section 11.0 of this manual.
- 8. Advise home/building owner of their responsibilities with respect to maintaining the boiler.



The building owner is responsible for keeping the Vent/Air-inlet termination free of snow, ice, or other potential blockages and for scheduling boiler routine maintenance as described in the next section. Failure to properly maintain the boiler may result in serious injury or death.

**Start-up**

Allow primers/cements to cure for 8 hours prior to Start-up. If curing time is less than 8 hours, first perform Steps 2 through 6 of **Mandatory Pre-commissioning Procedure for Plastic Venting** in Section 4.0. Failure to follow these instructions can result in explosion, serious injury or death.

- 1. Turn gas shut-off valve to the ON position.
- 2. Turn Power on to the boiler.
- 3. Set Controller to the desired settings.
- 4. Turn thermostat up, Ignition will occur.

**Operational Checklist**

- 1. System is free of gas leaks.
- 2. System is free of water leaks.
- 3. Water pressure is maintained above 15 PSI.
- 4. All air is purged from the heating system piping.
- 5. Ensure proper water flow rate; unit must not kettle, bang, hiss or flash the water to steam.
- 6. Ensure gas line pressure is in accordance with Section 9.0.
- 7. System is free of combustion leaks.
- 8. Unit must operate smoothly.
- 9. Ensure the flue gas combustion readings are within the tolerances listed in Table 9-1.
- 10. Each ignition must be smooth.
- 11. Verify that all condensate lines are clean and drain freely.

**Before Leaving**

- 1. Remove line pressure gauge from gas valve, tighten bleed screw, test screw for leaks. See Section 9.0.
- 2. Install plug into the flue gas test port and test for leaks, see Section 9.0.
- 3. Allow the boiler to complete at least one heating cycle, or to operate for at least 15 minutes.
- 4. Always verify proper operation after servicing.

**Instructions to Installing Contractor**

- 1. Ensure that the customer receives the Warranty Documentation included with the installation manual.
- 2. Leave the manual with the customer so they know when to call for annual maintenance and inspection.



This boiler must have water flowing through it whenever the burner is firing. Failure to comply may damage the unit, void the warranty, and cause serious injury or death.



Allowing the boiler to operate with a dirty combustion chamber will adversely affect its operation and void the warranty. Failure to clean the heat exchanger on a frequency that matches the need of the application may result in fire, property damage, or death.

## 14.0 ANNUAL MAINTENANCE AND INSPECTION

This unit must be inspected at the beginning of every heating season by a Qualified Technician.

### Annual Inspection Checklist

- 1. Lighting is smooth and consistent, and the combustion fan is noise & vibration free.
- 2. The condensate drain freely flows, and is cleaned of sediment.
- 3. Relief Valve and air vents are not weeping.
- 4. Low water cut off is tested (remove and clean a minimum of once every 5 years, see Section 10.0)
- 5. Examine all venting for evidence of leaks. Ensure vent screens are cleaned and clear of debris.
- 6. Inspect the flue sensor grommet seal and test port plug for leakage or signs of failure; replace if leaking or failing. Slant/Fin recommends replacing the test port plug annually.
- 7. Check the burner plate for signs of leaking.
- 8. The combustion chamber must be cleaned (cleaning frequency based on need for application – see below)
- 9. Keep boiler area clear and free from combustible materials, gasoline, and other flammable vapors and liquids.
- 10. Ensure there is nothing obstructing the flow of combustion and ventilation air.
- 11. Listen for water flow noises indicating a drop in boiler water flow rate.  
**Important** - The hydronic system may need to be flushed to eliminate hard water scale (Use Fernox DS-40 Descaler).
- 12. **Verify proper operation after servicing.**

### CAUTION

**Wiring Labels** - Label all wires prior to disconnection when servicing controls. Wiring errors can cause improper and dangerous operation.

### Combustion Chamber Cleaning Procedure

Slant/Fin recommends having the combustion chamber cleaned after the first year of operation, with subsequent cleanings scheduled based on the condition of the combustion chamber at the time. Units operating with LP Gas or in an industrial environment may require more frequent cleanings.

### IMPORTANT

**Crystalline Silica** - Read carefully the warnings and handling instructions pertaining to Refractory Ceramic Fibers before commencing any service work in the combustion chamber. Take all necessary precautions and use recommended personal protective equipment as required.

### Cleaning Checklist

- 1. Remove the demand for heat, allow the post-purge cycle to finish, turn gas and power supply off.
- 2. Working inside the cabinet, disconnect the cabling to the combustion blower, gas valve, spark igniter and flame sensor, then remove the air-inlet piping and Gas Valve/Venturi assembly (gas line is disconnected at the factory supplied union fitting).
- 3. Once the combustion chamber has cooled, remove the combustion blower followed by the burner plate – be careful not to damage the insulation disc located underneath the burner plate.
- 4. Use a vacuum with a high efficiency filter to remove any loose debris or dust.
- 5. Remove the condensate trap from the bottom of the boiler and place a drain under the boiler condensate drain.
- 6. Wet the inside of the combustion chamber with warm water (do not use any chemicals). Use a garden hose with a trigger nozzle to direct pressurized water through the heat exchanger tubes; the water will exit via the condensate drain on the bottom. Continue process until the tubes are clear and the water runs clean. Use dry rags or plastic to protect electrical components from being damaged by dripping or spraying water.
- 7. Disassemble the condensate trap and thoroughly clean it; then reassemble and securely connect it to the boiler condensate drain, see Section 6.0.
- 8. Remove the burner from the burner plate; clean if necessary using compressed air. Reattach the burner; ensure the gasket is in perfect condition and is reinstalled (replace if necessary).
- 9. Inspect the insulation disc located on the under-side of the burner plate. Replace if damaged.
- 10. Re-install the burner plate; be sure the insulation disc is properly aligned. Reinstall remaining components in the opposite order they were removed.
- 11. Perform the Start-up and Operational Checklist detailed in the previous section.

### WARNING

Replace any gaskets or insulation discs that show any signs of damage and do not re-use. Failure to follow these instructions may result in fire, property damage or death.

**Refractory Ceramic Fibers (RFC)**



**Personal Protective Equipment Recommended** - Read the following warnings and handling instructions carefully before commencing any service work in the combustion chamber. The insulating material on the inside of the burner plate contains *Refractory Ceramic Fibers* and should not be handled without personal protective equipment.



**Potential Carcinogen** - Use of *Refractory Ceramic Fibers* in high temperature applications (above 1000°C/1800°F) can result in the formation of Crystalline Silica (cristobalite), a respirable silica dust. Repeated airborne exposure to crystalline silica dust may result in chronic lung infections, acute respiratory illness, or death. Crystalline silica is listed as a (potential) occupational carcinogen by the following regulatory organizations: International Agency for Research on Cancer (IARC), Canadian Centre for Occupational Health and Safety (CCOHS), Occupational Safety and Health Administration (OSHA), and National Institute for Occupational Safety and Health (NIOSH). Failure to comply with handling instructions in Table 14-1 may result in serious injury or death.



**Crystalline Silica** - Certain components confined in the combustion chamber may contain this potential carcinogen. Improper installation, adjustment, alteration, service or maintenance can cause property damage, serious injury (exposure to hazardous materials) or death. Refer to Table 14-1 for handling instruction and recommended personal protective equipment. Installation and service must be performed by a qualified installer, service agency or the gas supplier (who must read and follow the supplied instructions before installing, servicing, or removing this boiler. This boiler contains materials that have been identified as carcinogenic, or possibly carcinogenic, to humans).

**Table 14-1 Handling Instructions for Refractory Ceramic Fibers (RCF)**

Reduce the Risk of Exposure	Precautions and Recommended Personal Protective Equipment
Avoid contact with skin and eyes	<ul style="list-style-type: none"> <li>Wear long-sleeved clothing, gloves, and safety goggles or glasses.</li> </ul>
Avoid breathing in silica dust	<ul style="list-style-type: none"> <li>Wear a respirator with an N95-rated filter efficiency or better.<sup>1</sup></li> <li>Use water to reduce airborne dust levels when cleaning the combustion chamber.</li> <li>Do not dry sweep silica dust. Pre-wet or use a vacuum with a high efficiency filter.</li> </ul>
Avoid transferring contamination	<ul style="list-style-type: none"> <li>When installing or removing RFCs, place the material in a sealable plastic bag.</li> <li>Remove contaminated clothing after use. Store in sealable container until cleaned.</li> <li>Wash contaminated clothing separately from other laundry.</li> </ul>
First Aid Measures	<p>If irritation persists after implementing first aid measures consult a physician.</p> <ul style="list-style-type: none"> <li><b>Skin</b> - Wash with soap and water.</li> <li><b>Eyes</b> - Do not rub eyes; flush with water immediately.</li> <li><b>Inhalation</b> – Breathe in fresh air; drink water, sneeze or cough to clear irritated passage ways.</li> </ul>

**Notes:**

<sup>1</sup> Respirator recommendations based on CCOHS and OSHA requirements at the time this document was written. Consult your local regulatory authority regarding current requirements for respirators, personal protective equipment, handling, and disposal of RCFs.

For more information on Refractory Ceramic Fibers, the risks, recommended handling procedures and acceptable disposal practices contact the organization(s) listed below:

**Canada (CCOHS):** Telephone directory listing under Government Blue Pages Canada—Health and Safety—Canadian Centre for Occupational Health and Safety; or website <http://www.ccohs.ca>.

**United States (OSHA):** Telephone directory listing under United States Government—Department of Labor—Occupational Safety and Health Administration; or website <http://www.osha.gov>.

## 15.0 TROUBLESHOOTING

**WARNING**

Observe the following precautions when servicing the boiler. Failure to comply with these may result in fire, property damage, serious injury or death.

### Servicing the Boiler

- Disconnect or shutoff all energy sources to the boiler: 120VAC power, water and gas.
- Identify and mark wires before disconnecting or removing them.
- Never bypass electrical fuses or limit devices except temporarily for testing.
- Use proper personal protective equipment (PPE) i.e. eye protection, safety footwear.

These procedures should only be performed by qualified service personnel, when abnormal operation of the boiler is suspected. The boiler incorporates a sophisticated microprocessor based control which normally responds appropriately to varying conditions. If the boiler operation appears to be incorrect, or it is not responding at all to a demand for heat, the following is suggested to determine and correct the problem.

**NOTICE**

Before undertaking any troubleshooting procedures it is highly recommended to have available a digital multimeter(s) capable of measuring AC and DC volts, Amperes, Resistance (Ohms) and Continuity.

### Check 120VAC and 24VAC at the Boiler

First, verify the following:

- There is 120V being supplied to the boiler:
  - The circuit breaker in the electrical panel supplying power to the boiler is not tripped.
  - The service switch (if applicable) is in the ON position.
  - The boiler service switch located on the front of the boiler is in the ON (1) position
- There is a heat call from the thermostat:
  - Verify 24VAC to thermostat.
  - The thermostat is placed at a sufficiently high setting to create a call for heat to the boiler.

To check for the presence of 120VAC and 24VAC at the boiler follow this procedure:

- Remove the boiler front cover (remove screw from bottom, undo side latches, then lift cover up and off).
- 120VAC
  - Remove the control panel cover. Loosen the three #8 hex-head sheet metal screws securing the cover to the control panel (one on the bottom, and one on each side). Lift the cover off and remove it from the unit; this will expose the field wiring barrier strips.
  - With an AC voltmeter set on the appropriate scale, measure the voltage across the L1 and L2 terminals (terminals 1 and 5).
  - If 120VAC is not detected, check the electrical service as suggested above. If the service is verified, inspect the circuit wiring from the panel to the boiler for broken or disconnected conductors.
  - If 120VAC is detected, turn power off to the boiler at the service switch and check the 120VAC fuse located on the right side of the control panel; refer to Figure 15-1 – replace if necessary.
- 24VAC (only check if 120VAC supply is verified).
  - Remove the control panel cover. Loosen the three #8 hex-head sheet metal screws securing the cover to the control panel (one on the bottom, and one on each side). Lift the cover off and remove it from the unit; this will expose the field wiring barrier strips.
  - With an AC voltmeter set on the appropriate scale, measure the voltage between the R and COM terminals (terminals 1 and 2).
  - If 24VAC is not detected, check the 24VAC fuse located at the transformer in the control panel; refer to Figure 15-1 – replace if necessary.

**WARNING**

Only replace fuses with identical parts, see Figure 15-1. Failure to follow this warning may result in component failure, fire, property damage, serious injury or death.

Figure 15-1 CHS Control Panel

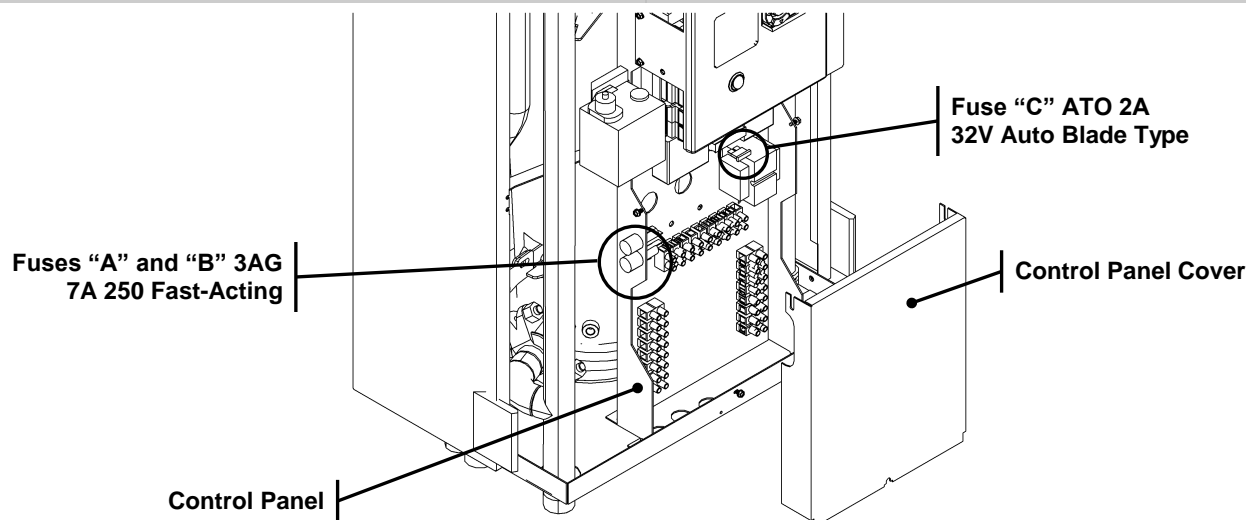

### Fuses

The CHS boiler is equipped with three (3) fuses. Check these fuses before replacing the controller or any other electrical component; if the fuse is blown, it will prevent the protected device(s) from functioning.

To check, and if necessary replace, the fuses:

- Remove all 120VAC power from the appliance. Be careful to check that the unit is not powered from more than one source e.g. a UPS (uninterruptible power supply).
- Remove the front cover.
- Fuses "A" and "B" are accessible by removing the spring-loaded knurled knob of their respective holders. Push the knob toward the panel, and twist approximately 1/4 turn counter-clockwise.
- Fuse "C" is an auto blade type and is installed in an "inline" fuse holder; gain access by removing the control panel cover.

After inspecting and if necessary replacing fuses, replace the panel cover and front cover. Restore power to the appliance and confirm proper operation.



**WARNING** Only replace fuses with identical parts, see Figure 15-1. Failure to follow this warning may result in component failure, fire, property damage, serious injury or death.

### User Interface (LCD Dot-Matrix Display)

The User Interface (display) provides the communication between the boiler controller and the user. If the communication fails, the User Interface will display, "Boiler Search, Modbus address: 1,2,3..." indefinitely, if the display loses power (or fails completely) the screen will appear blank. To troubleshoot these issues perform the following procedures:

#### Blank Screen

1. Confirm that 120VAC is being supplied to the boiler and that the service switch located below the display is turned ON (1).
2. Remove the front cover from the boiler; confirm that the green "power" light is illuminated on the boiler controller (Sola). If the light is NOT illuminated check the 24VAC fuse (Step 3); if the light is illuminated, proceed to Step 4.
3. Remove the control panel cover and check Fuse "C" (Auto Blade Type); if faulty check for shorts in the thermostat wiring, correct, then replace fuse (see Figure 15-1).
4. Ensure the Molex connector, located behind the display at the top, is connected and that the wires are fully inserted (see Figures 15-2 and 15-3). Verify that 5VDC is present between the Red and Black wires; if not trace wiring back to the boiler controller (see Figure 12-1); check for 5VDC at boiler controller (Sola).
5. Remove the display assembly from the control panel and check the wiring connections (see Figure 15-3).



**Loss of Communication**

If the Display is not blank, but is displaying “Boiler Search, Modbus address: 1,2,3...” indefinitely, ensure the Molex connector, located behind the display at the top, is connected and that the wires are fully inserted (see Figures 15-2 and 15-3). If the connector appears to be fine, check the wiring connections on the back of the display (remove display assembly - Figure 15-3); trace wiring back to boiler controller (Sola).

**Figure 15-2 Display Electrical Disconnect (Molex Connector)**

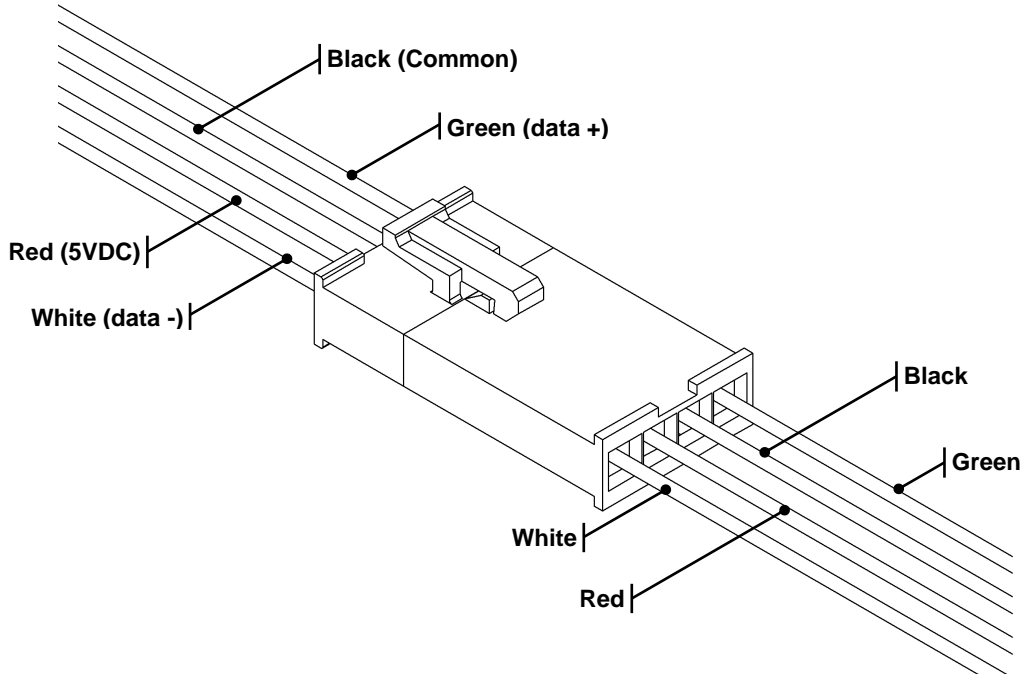

**Figure 15-3 Display Electrical Connection Access**

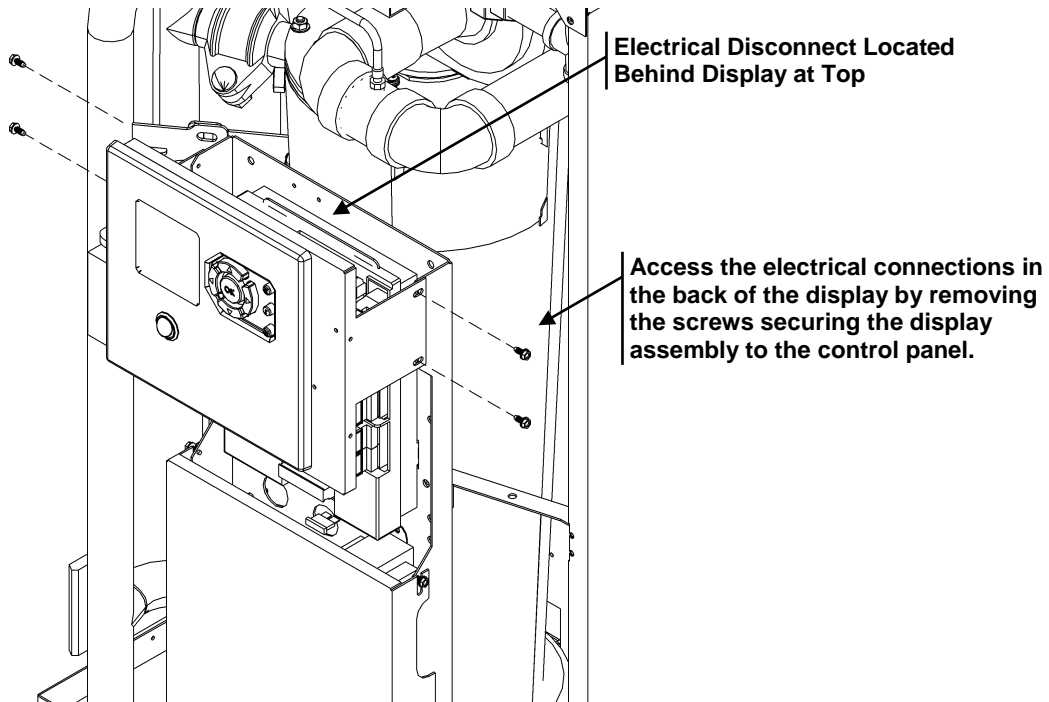

**Display Diagnostics** – The CHS controller and user interface provide detailed operational and diagnostic information for aid in troubleshooting. When power is applied to the boiler the initial screen displayed is the Home page. Information presented on the Home page includes Demand, State, status of sensors, and so forth. Any current Alert or Lockout condition is also displayed. Refer to *Appendix A - Controller and Display Instructions* for more information.

**Lockout and Alert History** – The controller maintains a record of the fifteen (15) most recent events for both Lockouts and Alerts (refer to *Appendix A - Controller and Display Instructions*). In any situation where a malfunction is suspected, always check the Alerts and Lockouts history. Entries recorded in the history provide useful information for determining the cause of the malfunction.

**Table 15-1 Troubleshooting Chart**

PROBLEM	POSSIBLE CAUSE	CORRECTIVE ACTION
Display shows “Boiler Search, Modbus address: 1,2,3...” constantly	Communication wire disconnected	See, “Loss of Communication” above.
	Faulty Sola controller or display	If wiring and connections are correct, replace display, then Sola controller.
Burner not operating	Heat demand satisfied; no call for heat	Check Demand and Setpoints via user interface. Check thermostat and DHW aquastat settings (as applicable).
	Appliance outlet temperature exceeds “Setpoint - On Hysteresis”	Check outlet temperature, setpoint and hysteresis settings via user interface.
	Hold, Delay or Lockout	Check Home page on user interface for code.
	Burner switch off	Check Home page, if Demand indicates “Burner switch off” go to Manual burner operation Test page and switch on (see Appendix A).
Lockout 2 – Waiting for safety data verification	Faulty Sola controller	Replace Sola controller
Lockout 9 – Flame bias out of range	4-20mA input being overdriven.	If using 4-20mA input, check to ensure current is not greater than 21mA.
	Control malfunction	Cycle power, if problem returns replace Sola controller.
Hold 27 – Flame sensor shorted to ground detected	A flame circuit shorted to ground may show up as a flame circuit timeout. Zero-Ohm shorts can display as Hold 27.	Check to ensure condensate drain is not blocked. Check to ensure no external voltage is applied to R & CH terminals. If using 4-20mA input, check to ensure current is not greater than 21mA.
Hold 61 – Anti short-cycle	Normal operation	Allow timer to expire, or reduce Anti short-cycle setting as needed (See Appendix A)
Hold 62 – Fan speed not proved	Normal Operation (Drive to Lightoff)	Hold 62 is momentarily displayed prior to burner ignition during the Drive to Lightoff.
	Blown fuse	Check Fuse "A", blown fuse prevents blower from operating.
	Wiring defect	Inspect blower wiring, ensure connectors at Sola controller and blower are securely attached.
	- Faulty Sola controller - Blower problem	If Hold 62 persists for 15 seconds or more, while the blower is running, check "Fan speed" indicated on display. If "LOW RPM", "HIGH RPM", "0" or rapidly changing RPM value is displayed, try connecting another Sola controller. If problem remains, replace blower.
Hold 63 – LCI OFF (Limit control input)	Incorrect Sola controller.	Replace control with correct model.
Hold 65 – Interrupted Air Switch OFF		

PROBLEM	POSSIBLE CAUSE	CORRECTIVE ACTION
Hold 66 – Interrupted air switch ON		
Hold 67 – ILK OFF	Low Water Condition	Check operation of internal LWCO.
	External Limit Tripped	Indication that an external limit (wired to “LIM”) is open. Not a problem with boiler, check external limit.
	Blocked Condensate Switch	Blocked Condensate Switch has opened – condensate is not draining from the boiler, or the exhaust venting is too restrictive or has a blockage. Check for blockages in the condensate trap and drain; clean accordingly. If drain is not blocked, check for blockages/restrictions in the exhaust venting, then clear the lockout.
Lockout or Hold 79 – Outlet High Limit	CH or DHW settings	Check if CH and/or DHW setpoint temperature plus off hysteresis exceed “High limit” setpoint – factory setting = 200°F (93°C).
	CH or DHW pump problem	See "Inoperative CH or DHW pump" below.
	Incorrect “Outlet high limit” setting	Increase “Outlet high limit” setting; maximum setting = 200°F (93°C).
	Incorrect “Outlet high limit response” setting	Unless deemed unacceptable by local installation codes, the “Outlet high limit response” should be set to “recycle and hold” to prevent lockout.
Lockout or Hold 81 – Delta T limit OR Appliance making banging or hissing sounds	Insufficient water flow	<ul style="list-style-type: none"> <li>• Check Fuse "B"</li> <li>• Check appliance pump.</li> <li>• Ensure plumbing is correct. Refer to Section 10.0 System Piping. Check that water pressure is at least 15PSI.</li> <li>• Boiler heat transfer surfaces may be fouled with scale or magnetite. Clean with Fernox DS-40 Descaler and Cleanser.</li> </ul>
Lockout 82 – Stack limit	Dirty heat exchanger	Inspect and if required clean the combustion chamber and/or heat exchanger. Refer to Section 14.0 Annual Maintenance and Inspection and Section 10.0 Boiler and Heating System Piping.
	Incorrect “Stack limit setpoint”	Unless installed in Canada with PVC exhaust venting, set “Stack limit setpoint” to maximum setting of 220°F (104°C). In Canada PVC exhaust venting is limited to 149°F (65°C).
Lockout 85 – Inlet/Outlet Inversion Limit	Pump flowing in the wrong direction	Ensure water circulation through the boiler is in the correct direction, see Figure 10-1.
Lockout or Hold 88 – Outlet T Rise limit	Insufficient water flow	See Lockout 81.
Hold 91– Inlet sensor fault	Sensor disconnected	Check sensor connection located on the bottom of the heat exchanger. Check connection on control board.
	Faulty sensor	Check resistance of sensor and compare to thermistor resistance chart, see Table 15-2.
Hold 92 – Outlet sensor fault	Sensor disconnected	Check sensor connection located on the top of the heat exchanger. Check connection on control board.
	Faulty sensor	Check resistance of sensor and compare to thermistor resistance chart, see Table 15-2. (Note the Outlet sensor incorporates two sensors, check resistance individually.)

PROBLEM	POSSIBLE CAUSE	CORRECTIVE ACTION
Hold 95 – Stack sensor fault	Sensor disconnected	Check sensor connection located at the bottom of the flue pipe inside the boiler cabinet. Check connection on control board.
	Faulty sensor	Check resistance of sensor and compare to thermistor resistance chart, see Table 15-2. (Note the Outlet sensor incorporates two sensors, check resistance individually.)
Lockout 109 or Hold 110 – Ignition failure occurred (failure to prove flame after 3 ignition attempts)	Incorrect spark igniter gap or faulty spark igniter	Check spark igniter gap – gap between electrodes should be 3/16 to 1/4 inch.
	Spark cable disconnected	Ensure that the high voltage spark cable is securely connected to the spark generator and the igniter electrode. Check that the green ground wire is securely attached to the ¼” quick connect tab on the igniter electrode.
	Blocked venting	Check for blockage of the exhaust-vent, Air-inlet, combustion blower, gas valve venturi, heat exchanger etc.
	Blocked condensate drain.	Clean condensate trap, inspect condensate drain for blockages and build-up – correct accordingly.
	Insufficient gas line pressure	Ensure the manual gas shutoff valve is open. Refer to Section 9.0 GAS VALVE AND BURNER SETUP.
	Flame rod disconnected	Verify that the flame rod signal wire is securely attached to the flame rod and the Sola controller.
	No 120VAC to Spark Generator	Check wiring from Sola controller to spark generator. With an AC voltmeter measure voltage across J5-6 and ground (the Sola controller chassis is connected to the 120VAC supply ground) during trial for ignition.
	Faulty Spark Generator	During trial for ignition check for arc on spark electrode via the observation port located next to the spark electrode in the burner door. If the spark generator is receiving 120VAC and no spark is observed, replace the spark generator.
	No 24VAC to Gas Valve	Check the wiring harness for loose or interrupted connections of the gas valve wiring. With an AC voltmeter, measure the voltage between Sola controller terminals J5-2 to J4-10. There should be 24VAC present during trial for ignition, if not replace Sola controller.
Faulty Gas Valve	The gas valve emits an audible click when it switches on or off. If the Sola controller is providing 24VAC to the gas valve, and the wiring is intact, it should be possible to detect if the valve is responding.	
Lockout 113 – Flame circuit timeout	A flame circuit shorted to ground may show up as a flame circuit timeout. High resistance shorts can display as Lockout 113.	Check to ensure condensate drain is not blocked. Check to ensure no voltage is applied to R & CH terminals. If using 4-20mA input, check to ensure current is not greater than 21mA.
Lockout 122 – Lightoff rate proving failed	Blower is not turning on	See “Blower not operating” below.
	Missing or incorrect blower feedback signal	See Hold 62 above.

PROBLEM	POSSIBLE CAUSE	CORRECTIVE ACTION
	Blower is always on	See “Blower operating at high speed while burner is off” below.
Alert 128 - Modulation rate was limited due to IAS open	Incorrect Sola controller.	Replace control with correct model.
Hold 137 – ILK failed to close	See Hold / Lockout 67	
Lockout 138 – Flame too low	Blocked venting	Check for blockage of the exhaust-vent, Air-inlet, combustion blower, gas valve venturi, heat exchanger etc.
	Fowled or faulty flame sensor	Inspect flame sensor for cracks or fowling, clean or replace as necessary.
	Incorrect combustion settings	Check combustion settings, correct accordingly.
Lockout 173 - Pilot relay feedback incorrect	External Electrical Noise	Look for sources of electrical noise, i.e. a large motor or multiple pieces of equipment starting at the same time.
Lockout 174 – Safety relay feedback incorrect	Failing Limit Switch in ILK circuit	Check operation of internal LWCO, and/or external limit (i.e. device connected between “R” and “LIM”); replace as necessary
	Hardware failure of Sola controller	Reset power, If problem persists replace Sola controller.
Alert 206 – Lead Lag header temperature was invalid	System Sensor not connected	If desired, install System Sensor and wire to SENSOR input connections “SYSTEM” and “COM”. Otherwise ignore Alert 206
Alert 233 – Lead Lag outdoor temperature was invalid	See Alert 248	
Alert 248 – CH outdoor temperature was invalid	Outdoor sensor not connected	The CHS is factory set with Outdoor Reset enabled. Connect outdoor sensor or disable Outdoor Reset.
	Outdoor sensor wiring	Check wiring of outdoor sensor. Wires should connect to SENSOR inputs “OUTDOOR” and “COM”.
	Faulty sensor	Check sensor. Should be free of ice and snow. Check resistance of sensor and compare to thermistor resistance chart, see Table 15-2.
Alert 448 – Flame too low	Blocked venting, dirty heat exchanger, failing flame sensor, poor combustion settings.	Indicates that the burner had to shut down due to insufficient flame signal. If Alert persists, refer to Lockout 138.
Alert 449 – Modulation rate was limited due to flame strength	Normal operation	Indicates that the minimum permissible modulation rate was temporarily increased due to low flame signal strength. If Alert persists, refer to Lockout 138.
Inoperative CH and/or DHW pump	Blown fuse	Check Fuse "B".
	Faulty Sola controller	If Fuse “B” not blown, and Sola controller is operating, navigate to pump diagnostic on display. Manually switch pump on, check for 120VAC at pump connection terminal on line voltage barrier strip. If 120VAC not detected, replace Sola controller.
	Faulty pump	If 120VAC supplied to pump, and pump does not operate, replace pump.

PROBLEM	POSSIBLE CAUSE	CORRECTIVE ACTION
Blower operating at high speed while burner is off	Blower signal cable disconnected	<ul style="list-style-type: none"> <li>Verify that the 5-position Molex connector on the wiring harness is securely connected to its mating connector on the blower.</li> <li>Check that the 4-position Molex connector on wiring harness is securely connected to its mating connector on the Sola controller.</li> </ul>
	No 24VAC to Sola controller	<ul style="list-style-type: none"> <li>Check Power LED on Sola controller.</li> <li>Check Fuse "C".</li> <li>With an AC voltmeter measure voltage at terminals J8 1 &amp; 2, 24VAC should be present.</li> </ul>
Blower not operating	Blower power disconnected	Verify that the 3-position Molex connector on the wiring harness is securely connected to its mating connector on the blower.
	Blown fuse	Check Fuse "A" using the procedure described above. Fuse "A" protects the blower as well as the ignition spark generator and appliance pump.
	Faulty blower	Measure voltage across pins 1 & 2 (black and white wires) of 3-position connector on wiring harness. If 120VAC detected, replace power connector and remove 5-position signal connector. Blower should rotate at high speed. If blower does not rotate, replace blower.

Table 15-2 Thermistor Resistance vs. Temperature

Temp °F (°C)	Resistance Ohms (Ω)	Temp °F (°C)	Resistance Ohms (Ω)
-22 (-30)	176,133	122 (50)	3,603
-4 (-20)	96,761	131 (55)	2,986
14 (-10)	55,218	140 (60)	2,488
32 (0)	32,650	149 (65)	2,083
41 (5)	25,390	158 (70)	1,752
50 (10)	19,900	167 (75)	1,481
59 (15)	15,710	176 (80)	1,258
68 (20)	12,490	185 (85)	1,072
77 (25)	10,000	194 (90)	918
86 (30)	8,057	203 (95)	789
95 (35)	6,531	212 (100)	680
104 (40)	5,327	230 (110)	506
113 (45)	4,369	-	-

Table 15-3 Hold and Lockout Codes

Code	Description	Note
0	None	Hold / No lockout
1	Unconfigured safety data	Lockout
2	Waiting for safety data verification	Lockout
3	Internal fault: Hardware fault	Hold
4	Internal fault: Safety Relay key feedback error	Hold
5	Internal fault: Unstable power (DCDC) output	Hold
6	Internal fault: Invalid processor clock	Hold
7	Internal fault: Safety relay drive error	Hold
8	Internal fault: Zero crossing not detected	Hold

Table 15-3 Hold and Lockout Codes

Code	Description	Note
9	Internal fault: Flame bias out of range	Hold
10	Internal fault: Invalid Burner control state	Lockout
11	Internal fault: Invalid Burner control state flag	Lockout
12	Internal fault: Safety relay drive cap short	Hold
13	Internal fault: PII shorted to ILK	Hold / Lockout
14	Internal fault: HFS shorted to LCI	Hold / Lockout
15	Internal fault: Safety relay test failed due to feedback ON	Lockout
16	Internal fault: Safety relay test failed due to safety relay OFF	Lockout
17	Internal fault: Safety relay test failed due to safety relay not OFF	Lockout
18	Internal fault: Safety relay test failed due to feedback not ON	Lockout
19	Internal fault: Safety RAM write	Lockout
20	Internal fault: Flame ripple and overflow	Hold
21	Internal fault: Flame number of sample mismatch	Hold
22	Internal fault: Flame bias out of range	Hold
23	Internal fault: Bias changed since heating cycle starts	Hold
24	Internal fault: Spark voltage stuck low or high	Hold
25	Internal fault: Spark voltage changed too much during flame sensing time	Hold
26	Internal fault: Static flame ripple	Hold
27	Internal fault: Flame rod shorted to ground detected	Hold
28	Internal fault: A/D linearity test fails	Hold
29	Internal fault: Flame bias cannot be set in range	Hold
30	Internal fault: Flame bias shorted to adjacent pin	Hold
31	Internal fault: SLO electronics unknown error	Hold
32	Internal fault: Safety Key 0	Lockout
33	Internal fault: Safety Key 1	Lockout
34	Internal fault: Safety Key 2	Lockout
35	Internal fault: Safety Key 3	Lockout
36	Internal fault: Safety Key 4	Lockout
37	Internal fault: Safety Key 5	Lockout
38	Internal fault: Safety Key 6	Lockout
39	Internal fault: Safety Key 7	Lockout
40	Internal fault: Safety Key 8	Lockout
41	Internal fault: Safety Key 9	Lockout
42	Internal fault: Safety Key 10	Lockout
43	Internal fault: Safety Key 11	Lockout
44	Internal fault: Safety Key 12	Lockout
45	Internal fault: Safety Key 13	Lockout
46	Internal fault: Safety Key 14	Lockout
47	Flame rod to ground leakage	Hold
48	Static flame (not flickering)	Hold
49	24VAC voltage low/high	Hold
50	Modulation fault	Hold
51	Pump fault	Hold
52	Motor tachometer fault	Hold
53	AC inputs phase reversed	Lockout
54	Safety GVT model ID doesn't match application's model ID	Lockout
55	Application configuration data block CRC errors	Lockout
56-57	RESERVED	
58	Internal fault: HFS shorted to IAS	Lockout

Table 15-3 Hold and Lockout Codes

Code	Description	Note
59	Internal fault: Mux pin shorted	Lockout
60	Internal fault: HFS shorted to LFS	Lockout
61	Anti short cycle	Hold
62	Fan speed not proved	Hold
63	LCI OFF	Hold
64	PII OFF	N/A
65	Interrupted Airflow Switch OFF	Hold
66	Interrupted Airflow Switch ON	Hold
67	ILK OFF	Hold
68	ILK ON	N/A
69	Pilot test hold	Hold
70	Wait for leakage test completion	Hold
71	Input power frequency mismatch	Lockout
72-77	RESERVED	
78	Demand lost in run	Hold
79	Outlet high limit	Hold
80	DHW high limit	Disabled
81	Delta T limit	Hold / Lockout
82	Stack limit	Lockout
83	Delta T exchanger/outlet limit	Disabled
84	Delta T inlet/exchanger limit	Disabled
85	Inlet/Outlet inversion limit (See Table 17-1)	Hold
86	Exchanger/outlet inversion limit	Disabled
87	Inlet/exchanger inversion limit	Disabled
88	Outlet T-Rise limit (See Table 17-1)	Lockout
89	Exchanger T-rise limit	Disabled
90	Heat exchanger high limit	Disabled
91	Inlet sensor fault	Hold
92	Outlet sensor fault	Hold
93	DHW sensor fault	Hold
94	Header sensor fault	Hold
95	Stack sensor fault	Hold
96	Outdoor sensor fault	Hold
97	Internal fault: A2D mismatch	Lockout
98	Internal fault: Exceeded VSNSR voltage tolerance	Lockout
99	Internal fault: Exceeded 28V voltage tolerance	Lockout
100	Pressure sensor fault	Hold
101	Exchanger sensor fault	Disabled
102-104	RESERVED	
105	Flame detected out of sequence	Hold / Lockout
106	Flame lost in MFEP	Lockout
107	Flame lost early in run	Lockout
108	Flame lost in run	Lockout
109	Ignition failed	Lockout
110	Ignition failure occurred	Hold
111	Flame current lower than WEAK threshold	Hold
112	Pilot test flame timeout	Lockout
113	Flame circuit timeout	Lockout
114-115	RESERVED	



Table 15-3 Hold and Lockout Codes

Code	Description	Note
116	Wait for OK to Run	Disabled
117	Flap valve condensate fault	Disabled
118	Controller interaction system fault	Hold
119	Controller interaction communications fault	Hold
120	Flap valve backflow fault	Disabled
121	Flap valve fault	Disabled
122	Light off rate proving failed	Lockout
123	Purge rate proving failed	Lockout
124	High fire switch OFF	Hold
125	High fire switch stuck ON	Hold
126	Low fire switch OFF	Hold
127	Low fire switch stuck ON	Hold
128	Fan speed failed during pre-purge	Hold / Lockout
129	Fan speed failed during pre-ignition	Hold / Lockout
130	Fan speed failed during ignition	Hold / Lockout
131	Fan movement detected during standby	Hold
132	Fan speed failed during run	Hold
133-135	RESERVED	
136	Interrupted Airflow Switch failed to close	Hold
137	ILK failed to close	Hold
138	Flame too low	Lockout
139-142	RESERVED	
143	Internal fault: Flame bias out of range 1	Lockout
144	Internal fault: Flame bias out of range 2	Lockout
145	Internal fault: Flame bias out of range 3	Lockout
146	Internal fault: Flame bias out of range 4	Lockout
147	Internal fault: Flame bias out of range 5	Lockout
148	Internal fault: Flame bias out of range 6	Lockout
149	Flame detected	Hold / Lockout
150	Flame not detected	Hold
151	High fire switch ON	Hold / Lockout
152	Combustion pressure ON	Hold / Lockout
153	Combustion pressure OFF	Hold / Lockout
154	Purge fan switch ON	Hold / Lockout
155	Purge fan switch OFF	Hold / Lockout
156	Combustion pressure and Flame ON	Hold / Lockout
157	Combustion pressure and Flame OFF	Lockout
158	Main valve ON	Lockout
159	Main valve OFF	Lockout
160	Ignition ON	Lockout
161	Ignition OFF	Lockout
162	Pilot valve ON	Lockout
163	Pilot valve OFF	Lockout
164	Block intake ON	Lockout
165	Block intake OFF	Lockout
166-168	RESERVED	
169	Safety opto bad in test state	Lockout
170	Safety relay opto feedback incorrect	Lockout
171	Safety relay feedback incorrect in run	Lockout

Table 15-3 Hold and Lockout Codes

Code	Description	Note
172	Main relay feedback incorrect	Lockout
173	Pilot relay feedback incorrect	Lockout
174	Safety relay feedback incorrect	Lockout
175	Safety relay open	Lockout
176	Main relay ON at safe start check	Lockout
177	Pilot relay ON at safe start check	Lockout
178	Safety relay ON at safe start check	Lockout
179-180	RESERVED	
181	Invalid Blocked condensate enable setting	Disabled
182	Invalid J7-1 configuration, both LFS and Blocked condensate	Disabled
183	Invalid J7-2 configuration, both HFS and Flap valve	Disabled
184	Invalid BLOWER/HSI output setting	Lockout
185	Invalid Delta T limit enable setting	Lockout
186	Invalid Delta T limit response setting	Lockout
187	Invalid DHW high limit enable setting	Lockout
188	Invalid DHW high limit response setting	Lockout
189	Invalid Flame sensor type setting	Lockout
190	Invalid interrupted air switch enable setting	Lockout
191	Invalid interrupted air switch start check enable setting	Lockout
192	Invalid Igniter on during setting	Lockout
193	Invalid Ignite failure delay setting	Lockout
194	Invalid Ignite failure response setting	Lockout
195	Invalid Ignite failure retries setting	Lockout
196	Invalid Ignition source setting	Lockout
197	Invalid Interlock open response setting	Lockout
198	Invalid Interlock start check setting	Lockout
199	Invalid LCI enable setting	Lockout
200	Invalid light off rate setting	Lockout
201	Invalid Light off rate proving setting	Lockout
202	Invalid Main Flame Establishing Period time setting	Lockout
203	Invalid MFEP flame failure response setting	Lockout
204	Invalid NTC sensor type setting	Lockout
205	Invalid Outlet high limit response setting	Lockout
206	Invalid Pilot Flame Establishing Period setting	Lockout
207	Invalid PII enable setting	Lockout
208	Invalid pilot test hold setting	Lockout
209	Invalid Pilot type setting	Lockout
210	Invalid Post-purge time setting	Lockout
211	Invalid Power up with lockout setting	Lockout
212	Invalid Pre-ignition time setting	Lockout
213	Invalid Pre-purge rate setting	Lockout
214	Invalid Pre-purge time setting	Lockout
215	Invalid Purge rate proving setting	Lockout
216	Invalid Run flame failure response setting	Lockout
217	Invalid Run stabilization time setting	Lockout
218	Invalid Stack limit enable setting	Lockout
219	Invalid Stack limit response setting	Lockout
220	Unconfigured Delta T limit set point setting	Lockout
221	Unconfigured DHW high limit set point setting	Lockout

Table 15-3 Hold and Lockout Codes

Code	Description	Note
222	Unconfigured Outlet high limit set point setting	Lockout
223	Unconfigured Stack limit set point setting	Lockout
224	Invalid DHW demand source setting	Lockout
225	Invalid Flame threshold setting	Lockout
226	Invalid Outlet high limit set point setting	Lockout
227	Invalid DHW high limit set point setting	Lockout
228	Invalid Stack limit set point setting	Lockout
229	Invalid Modulation output setting	Lockout
230	Invalid CH demand source setting	Lockout
231	Invalid Delta T limit delay setting	Lockout
232	Invalid Pressure sensor type setting	Lockout
233	Invalid IAS closed response setting	Lockout
234	Invalid Outlet high limit enable setting	Lockout
235	Invalid Outlet connector type setting	Lockout
236	Invalid Inlet connector type setting	Lockout
237	Invalid DHW connector type setting	Lockout
238	Invalid Stack connector type setting	Lockout
239	Invalid Header connector type setting	Lockout
240	Invalid Outdoor connector type setting	Lockout
241	Exchanger sensor not allowed with stack connector setting	Lockout
242	Invalid DHW auto detect configuration	Lockout
243	Invalid UV with spark interference not compatible with Igniter on throughout	Lockout
244	Internal fault: Safety relay test invalid state	Lockout
245	Invalid Outlet connector type setting for T-rise	Lockout
246	4-20mA cannot be used for both modulation and setpoint control	Lockout
247	Invalid ILK bounce detection enable	Lockout
248	Invalid forced recycle interval	Lockout
249	STAT cannot be demand source when Remote Stat is enabled	Lockout
250	Invalid Fan speed error response	Lockout
251	Lead drop-stage on error setting does not match drop method configuration	Lockout
252	Invalid Line frequency setting	Lockout
253	Lead Lag modulation sensor not valid with setpoint source	Lockout
254	Lead Lag modulation sensor not valid with local setpoint source	Lockout
255	Lead Lag modulation sensor not valid with local modulation source	Lockout
256	Selected Controller interaction enable setting is not allowed	Lockout
257	Controller interaction enable does not match neighbor stack fault setting	Lockout
258	Controller ID must be non-zero if controller interaction is enabled	Lockout
259	Modulation output must be fan if controller interaction is enabled	Lockout
260	Asymmetrical paired (no flap) is set but flap switch input is energized	Lockout
261	Neighbor burner control blower fault detected	Lockout
262	Blower fault detected during flap test	Lockout
263	Invalid DHW demand temperature setting	Lockout
264	Invalid preferred outlet high limit setting	Lockout
265	Invalid preferred lightoff rate setting	Lockout
266	Invalid preferred stack limit rate setting	Lockout

Table 15-4 Alert Codes

Code	Description
0	None (No alert)
1	Alert PCB was restored from factory defaults
2	Safety configuration parameters were restored from factory defaults
3	Configuration parameters were restored from factory defaults
4	Invalid Factory Invisibility PCB was detected
5	Invalid Factory Range PCB was detected
6	Invalid range PCB record has been dropped
7	EEPROM lockout history was initialized
8	Switched application annunciation data blocks
9	Switched application configuration data blocks
10	Configuration was restored from factory defaults
11	Backup configuration settings was restored from active configuration
12	Annunciation configuration was restored from factory defaults
13	Annunciation configuration was restored from backup
14	Safety group verification table was restored from factory defaults
15	Safety group verification table was updated
16	Invalid Parameter PCB was detected
17	Invalid Range PCB was detected
18	Alarm silence time exceeded maximum
19	Invalid safety group verification table was detected
20	Backdoor password could not be determined
21	Invalid safety group verification table was not accepted
22	CRC errors were found in application configuration data blocks
23	Backup Alert PCB was restored from active one
24	RESERVED
25	Lead Lag operation switch was turned OFF
26	Lead Lag operation switch was turned ON
27	Safety processor was reset
28	Application processor was reset
29	Burner switch was turned OFF
30	Burner switch was turned ON
31	Program Module (PM) was inserted into socket
32	Program Module (PM) was removed from socket
33	Alert PCB was configured
34	Parameter PCB was configured
35	Range PCB was configured
36	Program Module (PM) incompatible with product was inserted into socket
37	Program Module application parameter revision differs from application processor
38	Program Module safety parameter revision differs from safety processor
39	PCB incompatible with product contained in Program Module
40	Parameter PCB in Program Module is too large for product
41	Range PCB in Program Module was too large for product
42	Alert PCB in Program Module was too large for product
43	IAS start check was forced on due to IAS enabled
44	Low voltage was detected in safety processor
45	High line frequency occurred
46	Low line frequency occurred
47	Invalid subsystem reset request occurred
48	Write large enumerated Modbus register value was not allowed

Table 15-4 Alert Codes

Code	Description
49	Maximum cycle count was reached
50	Maximum hours count was reached
51	Illegal Modbus write was attempted
52	Modbus write attempt was rejected (NOT ALLOWED)
53	Illegal Modbus read was attempted
54	Safety processor brown-out reset occurred
55	Application processor watchdog reset occurred
56	Application processor brown-out reset occurred
57	Safety processor watchdog reset occurred
58	Alarm was reset by the user at the control
59	Burner control firing rate was > absolute max rate
60	Burner control firing rate was < absolute min rate
61	Burner control firing rate was invalid, % vs. RPM
62	Burner control was firing with no fan request
63	Burner control rate (non-firing) was > absolute max rate
64	Burner control rate (non-firing) was < absolute min rate
65	Burner control rate (non-firing) was absent
66	Burner control rate (non-firing) was invalid, % vs. RPM
67	Fan off cycle rate was invalid, % vs. RPM
68	Set point was over ridden due to sensor fault
69	Modulation was over ridden due to sensor fault
70	No demand source was set due to demand priority conflicts
71	CH 4-20mA signal was invalid.
72	Flame strength rate differential was invalid
73	Flame strength step rate was invalid
74	Periodic forced recycle
75	Absolute max fan speed was out of range
76	Absolute min fan speed was out of range
77	Fan gain down was invalid
78	Fan gain up was invalid
79	Fan minimum duty cycle was invalid
80	Fan pulses per revolution was invalid
81	Fan PWM frequency was invalid
82-83	RESERVED
84	Lead Lag CH 4-20mA water temperature setting was invalid
85	No Lead Lag add stage error threshold was configured
86	No Lead Lag add stage detection time was configured
87	No Lead Lag drop stage error threshold was configured
88	No Lead Lag drop stage detection time was configured
89	Lead Lag all boiler off threshold was invalid
90	Modulation output type was invalid
91	Firing rate control parameter was invalid
92	Forced rate was out of range vs. min/max modulation
93	Forced rate was invalid, % vs. RPM
94	Slow start ramp value was invalid
95	Slow start degrees value was invalid
96	Slow start was ended due to outlet sensor fault
97	Slow start was end due to reference set point fault
98	CH max modulation rate was invalid, % vs. RPM

Table 15-4 Alert Codes

Code	Description
99	CH max modulation rate was > absolute max rate
100	CH modulation range (max minus min) was too small (< 4% or 40 RPM)
101	DHW max modulation rate was invalid, % vs. RPM
102	DHW max modulation rate was > absolute max rate
103	DHW modulation range (max minus min) was too small (< 4% or 40 RPM)
104	Min modulation rate was < absolute min rate
105	Min modulation rate was invalid, % vs. RPM
106	Manual rate was invalid, % vs. RPM
107	Slow start enabled, but forced rate was invalid
108	Analog output hysteresis was invalid
109	Analog modulation output type was invalid
110	IAS open rate differential was invalid
111	IAS open step rate was invalid
112	Mix max modulation rate was invalid, % vs. RPM
113	Mix max modulation rate was > absolute max or < absolute min rates
114	Mix modulation range (max minus min) was too small (< 4% or 40 RPM)
115	Fan was limited to its minimum duty cycle
116	Manual rate was > CH max modulation rate
117	Manual rate was > DHW max modulation rate
118	Manual rate was < min modulation rate
119	Manual rate in Standby was > absolute max rate
120	Modulation commanded rate was > CH max modulation rate
121	Modulation commanded rate was > DHW max modulation rate
122	Modulation commanded rate was < min modulation rate
123	Modulation rate was limited due to outlet limit
124	Modulation rate was limited due to Delta-T limit
125	Modulation rate was limited due to stack limit
126	Modulation rate was limited due to anti-condensation
127	Fan Speed out of range in RUN
128	Modulation rate was limited due to IAS was open
129	Slow start ramp setting of zero will result in no modulation rate change
130	No forced rate was configured for slow start ramp
131	CH demand source was invalid
132	CH P-gain was invalid
133	CH I-gain was invalid
134	CH D-gain was invalid
135	CH OFF hysteresis was invalid
136	CH ON hysteresis was invalid
137	CH sensor type was invalid
138	CH hysteresis step time was invalid
139	CH remote control parameter was invalid
140	CH ODR not allowed with remote control
146	CH control was suspended due to fault
147	CH header temperature was invalid
148	CH outlet temperature was invalid
149	CH steam pressure was invalid
151	Minimum water temperature parameter was greater than setpoint
152	Minimum water temperature parameter was greater than time of day setpoint
155	CH modulation rate source parameter was invalid

**Table 15-4 Alert Codes**

Code	Description
157	DHW demand source was invalid
158	DHW P-gain was invalid
159	DHW I-gain was invalid
160	DHW D-gain was invalid
161	DHW OFF hysteresis was invalid
162	DHW ON hysteresis was invalid
163	DHW hysteresis step time was invalid
164	DHW sensor type was invalid
165	Inlet sensor type was invalid for DHW
166	Outlet sensor type was invalid for DHW
167	DHW storage OFF hysteresis was invalid
168	DHW storage ON hysteresis was invalid
169	DHW modulation sensor type was invalid
170	DHW modulation sensor was not compatible for Auto mode
171	DHW control was suspended due to fault
172	DHW temperature was invalid
173	DHW inlet temperature was invalid
174	DHW outlet temperature was invalid
175	DHW high limit must be disabled for Auto mode
176	DHW sensor type was not compatible for Auto mode
177	DHW priority source setting was invalid
178	DHW priority method setting was invalid
179	CH S5 (J8-11) sensor was invalid
180	CH Inlet temperature was invalid
181	CH S10 (J10-7) sensor was invalid
182	Lead Lag CH setpoint source was invalid
183	Lead Lag P-gain was invalid
184	Lead Lag I-gain was invalid
185	Lead Lag D-gain was invalid
186	Lead Lag OFF hysteresis was invalid
187	Lead Lag ON hysteresis was invalid
188	Lead Lag slave enable was invalid
189	Lead Lag hysteresis step time was invalid
190	No Lead Lag Modbus port was assigned
191	Lead Lag base load common setting was invalid
192	Lead Lag DHW demand switch setting was invalid
193	Lead Lag Mix demand switch setting was invalid
194	Lead Lag modulation sensor setting was invalid
195	Lead Lag backup modulation sensor setting was invalid
196	Lead Lag slave mode setting was invalid
197	Lead Lag rate allocation setting was invalid
198	Lead selection setting was invalid
199	Lag selection setting was invalid
200	Lead Lag slave return setting was invalid
201	Lead Lag add stage method setting was invalid
202	STAT may not be a Lead Lag CH demand source when Remote Stat is enabled
203	Lead Lag base load rate setting was invalid
204	Lead Lag master was suspended due to fault
205	Lead Lag slave was suspended due to fault

Table 15-4 Alert Codes

Code	Description
206	Lead Lag header temperature was invalid
207	Lead Lag was suspended due to no enabled Program Module installed
208	Lead Lag slave session has timed out
209	Too many Lead Lag slaves were detected
210	Lead Lag slave was discovered
211	Incompatible Lead Lag slave was discovered
212	No base load rate was set for Lead Lag slave
213	Lead Lag slave unable to fire before demand to fire delay expired
214	Adding Lead Lag slave aborted due to add requirement change
215	No Lead Lag slaves available to service demand
216	No Lead Lag active service was set due to demand priority conflicts
217	No Lead Lag add stage method was specified
218	No Lead Lag drop stage method was specified
219	Using backup Lead Lag header sensor due to sensor failure
220	Lead Lag frost protection rate was invalid
221	Lead Lag drop stage method setting was invalid
222	CH frost protection temperature was invalid
223	CH frost protection inlet temperature was invalid
224	DHW frost protection temperature was invalid
225	No anticondensation setpoint was configured for frost protection
226	RESERVED
227	DHW priority override time was not derated due to invalid outdoor temperature
228	Warm weather shutdown was not checked due to invalid outdoor temperature
229	Lead Lag slave communication timeout
230	RESERVED
231	LL set point was invalid
232	LL time of day set point was invalid
233	LL outdoor temperature was invalid
234	LL ODR time of day set point was invalid
235	LL ODR time of day set point exceeded normal set point
236	LL max outdoor set point was invalid
237	LL min outdoor set point was invalid
238	LL min water set point was invalid
239	LL outdoor temperature range was too small (minimum 12 C / 22 F)
240	LL water temperature range was too small (minimum 12 C / 22 F)
241	Lead Lag DHW setpoint was invalid
243	Lead Lag CH demand switch was invalid
244	Lead Lag ODR min water temperature was invalid
245	RESERVED
246	CH set point was invalid
247	CH time of day set point was invalid
248	CH outdoor temperature was invalid
249	CH ODR time of day setpoint was invalid
250	CH ODR time of day set point exceeds normal set point
251	CH max outdoor set point was invalid
252	CH min outdoor setpoint was invalid
253	CH min water set point was invalid
254	CH outdoor temperature range was too small (minimum 12 C / 22 F)
255	CH water temperature range was too small (minimum 12 C / 22 F)



**Table 15-4 Alert Codes**

Code	Description
259	CH ODR min water temperature was invalid
260	RESERVED
261	DHW set point was invalid
262	DHW time of day set point was invalid
263	DHW storage setpoint was invalid
264	STAT may not be a DHW demand source when Remote Stat is enabled
265	No DHW anticondensation setpoint was configured
266	No CH anticondensation setpoint was configured
267	STAT may not be a CH demand source when Remote Stat is enabled
268	CH 4mA water temperature setting was invalid
269	CH 20mA water temperature setting was invalid
270	Steam 4mA water temperature setting was invalid
271	Steam 20mA water temperature setting was invalid
272	Abnormal Recycle: Pressure sensor fault
273	Abnormal Recycle: Safety relay drive test failed
274	Abnormal Recycle: Demand off during Pilot Flame Establishing Period
275	Abnormal Recycle: LCI off during Drive to Purge Rate
276	Abnormal Recycle: LCI off during Measured Purge Time
277	Abnormal Recycle: LCI off during Drive to Light off Rate
278	Abnormal Recycle: LCI off during Pre-Ignition test
279	Abnormal Recycle: LCI off during Pre-Ignition time
280	Abnormal Recycle: LCI off during Main Flame Establishing Period
281	Abnormal Recycle: LCI off during Ignition period
282	Abnormal Recycle: Demand off during Drive to Purge Rate
283	Abnormal Recycle: Demand off during Measured Purge Time
284	Abnormal Recycle: Demand off during Drive to Light off Rate
285	Abnormal Recycle: Demand off during Pre-Ignition test
286	Abnormal Recycle: Demand off during Pre-Ignition time
287	Abnormal Recycle: Flame was on during Safe Start check
288	Abnormal Recycle: Flame was on during Drive to Purge Rate
289	Abnormal Recycle: Flame was on during Measured Purge Time
290	Abnormal Recycle: Flame was on during Drive to Light off Rate
291	Abnormal Recycle: Flame was not on at end of Ignition period
292	Abnormal Recycle: Flame was lost during Main Flame Establishing Period
293	Abnormal Recycle: Flame was lost early in Run
294	Abnormal Recycle: Flame was lost during Run
295	Abnormal Recycle: Leakage test failed
296	Abnormal Recycle: Interrupted air flow switch was off during Drive to Purge Rate
297	Abnormal Recycle: Interrupted air flow switch was off during Measured Purge Time
298	Abnormal Recycle: Interrupted air flow switch was off during Drive to Light off Rate
299	Abnormal Recycle: Interrupted air flow switch was off during Pre-Ignition test
300	Abnormal Recycle: Interrupted air flow switch was off during Pre-Ignition time
301	Abnormal Recycle: Interrupted air flow switch was off during Main Flame Establishing Period
302	Abnormal Recycle: Ignition failed due to interrupted air flow switch was off
303	Abnormal Recycle: ILK off during Drive to Purge Rate
304	Abnormal Recycle: ILK off during Measured Purge Time
305	Abnormal Recycle: ILK off during Drive to Light off Rate
306	Abnormal Recycle: ILK off during Pre-Ignition test
307	Abnormal Recycle: ILK off during Pre-Ignition time

Table 15-4 Alert Codes

Code	Description
308	Abnormal Recycle: ILK off during Main Flame Establishing Period
309	Abnormal Recycle: ILK off during Ignition period
310	Run was terminated due to ILK was off
311	Run was terminated due to interrupted air flow switch was off
312	Stuck reset switch
313	Run was terminated due to fan failure
314	Abnormal Recycle: Fan failed during Drive to Purge Rate
315	Abnormal Recycle: Fan failed during Measured Purge Time
316	Abnormal Recycle: Fan failed during Drive to Light off Rate
317	Abnormal Recycle: Fan failed during Pre-Ignition test
318	Abnormal Recycle: Fan failed during Pre-Ignition time
319	Abnormal Recycle: Fan failed during Ignition period
320	Abnormal Recycle: Fan failed during Main Flame Establishing Period
321	Abnormal Recycle: Main Valve off after 10 seconds of RUN
322	Abnormal Recycle: Pilot Valve off after 10 seconds of RUN
323	Abnormal Recycle: Safety Relay off after 10 seconds of RUN
324	Abnormal Recycle: Hardware flame bias
325	Abnormal Recycle: Hardware static flame
326	Abnormal Recycle: Hardware flame current invalid
327	Abnormal Recycle: Hardware flame rod short
328	Abnormal Recycle: Hardware invalid power
329	Abnormal Recycle: Hardware invalid AC line
330	Abnormal Recycle: Hardware SLO flame ripple
331	Abnormal Recycle: Hardware SLO flame sample
332	Abnormal Recycle: Hardware SLO flame bias range
333	Abnormal Recycle: Hardware SLO flame bias heat
334	Abnormal Recycle: Hardware SLO spark stuck
335	Abnormal Recycle: Hardware SLO spark changed
336	Abnormal Recycle: Hardware SLO static flame
337	Abnormal Recycle: Hardware SLO rod shorted
338	Abnormal Recycle: Hardware SLO AD linearity
339	Abnormal Recycle: Hardware SLO bias not set
340	Abnormal Recycle: Hardware SLO bias shorted
341	Abnormal Recycle: Hardware SLO electronics
342	Abnormal Recycle: Hardware processor clock
343	Abnormal Recycle: Hardware AC phase
344	Abnormal Recycle: Hardware A2D mismatch
345	Abnormal Recycle: Hardware VSNSR A2D
346	Abnormal Recycle: Hardware 28V A2D
347	Abnormal Recycle: Hardware HFS IAS shorted
348	Abnormal Recycle: Hardware PII INTLK shorted
349	Abnormal Recycle: Hardware HFS LCI shorted
350	Abnormal Recycle: Hardware HFS LFS shorted
351	Abnormal Recycle: Invalid zero crossing
352	Abnormal Recycle: fault stack sensor
353	Abnormal Recycle: stack limit
354	Abnormal Recycle: delta T limit
355	Abnormal Recycle: fault outlet sensor
356	Abnormal Recycle: outlet high limit

**Table 15-4 Alert Codes**

Code	Description
357	Abnormal Recycle: fault DHW sensor
358	Abnormal Recycle: DHW high limit
359	Abnormal Recycle: fault inlet sensor
360	Abnormal Recycle: Check Parameters Failed
361	Internal error: No factory parameters were detected in control
362	Internal error: PID iteration frequency was invalid
363	Internal error: Demand-Rate interval time was invalid
364	Internal error: Factory calibration parameter for modulation was invalid
365	Internal error: CH PID P-scaler was invalid
366	Internal error: CH PID I-scaler was invalid
367	Internal error: CH PID D-scaler was invalid
368	Internal error: DHW PID P-scaler was invalid
369	Internal error: DHW PID I-scaler was invalid
370	Internal error: DHW PID D-scaler was invalid
371	Internal error: Lead Lag master PID P-scaler was invalid
372	Internal error: Lead Lag master PID I-scaler was invalid
373	Internal error: Lead Lag master PID D-scaler was invalid
374	Abnormal Recycle: Hardware flame bias high
375	Abnormal Recycle: Hardware flame bias low
376	Abnormal Recycle: Hardware flame bias delta high
377	Abnormal Recycle: Hardware flame bias delta low
378	Abnormal Recycle: Hardware flame bias dynamic high
379	Abnormal Recycle: Hardware flame bias dynamic low
380	Abnormal Recycle: Fan Speed Not Proven
381	Abnormal Recycle: Fan Speed Range Low
382	Abnormal Recycle: Fan Speed Range High
383	Abnormal Recycle: Pre-Ignition test failed, recycle
384-388	RESERVED
389	Abnormal Recycle: AC power frequency Mismatch
390-447	RESERVED
448	Flame too low
449	Modulation rate was limited due to flame strength
450	RESERVED
451	Circulator control was invalid
452	Circulator P-gain was invalid
453	Circulator I-gain was invalid
454	Circulator temperature was invalid
455	Circulator outlet temperature was invalid
456	Circulator inlet temperature was invalid
457	Circulator outlet temperature was invalid
458	Circulator sensor choice was invalid
459	Circulator PID setpoint was invalid
460	LCI demand lost in run
461	Demand lost in run
462	STAT demand lost in run
463	Demand lost in run due to no flame
464	LCI lost in Combustion Pressure Establishing Period
465	LCI lost in Combustion Pressure Stabilizing Period
466	RESERVED

Table 15-4 Alert Codes

Code	Description
467	Internal error: EEPROM write was attempted before EEPROM was initialized
468	Internal error: EEPROM cycle count address was invalid
469	Internal error: EEPROM days count address was invalid
470	Internal error: EEPROM hours count address was invalid
471	Internal error: Lockout record EEPROM index was invalid
472	Internal error: Request to write PM status was invalid
473	Internal error: PM parameter address was invalid
474	Internal error: PM safety parameter address was invalid
475	Internal error: Invalid record in lockout history was removed
476	Internal error: EEPROM write buffer was full
477	Internal error: Data too large was not written to EEPROM
478	Internal error: Safety key bit 0 was incorrect
479	Internal error: Safety key bit 1 was incorrect
480	Internal error: Safety key bit 2 was incorrect
481	Internal error: Safety key bit 3 was incorrect
482	Internal error: Safety key bit 4 was incorrect
483	Internal error: Safety key bit 5 was incorrect
484	Internal error: Safety key bit 6 was incorrect
485	Internal error: Safety key bit 7 was incorrect
486	Internal error: Safety key bit 8 was incorrect
487	Internal error: Safety key bit 9 was incorrect
488	Internal error: Safety key bit 10 was incorrect
489	Internal error: Safety key bit 11 was incorrect
490	Internal error: Safety key bit 12 was incorrect
491	Internal error: Safety key bit 13 was incorrect
492	Internal error: Safety key bit 14 was incorrect
493	Internal error: Safety key bit 15 was incorrect
494	Internal error: Safety relay timeout
495	Internal error: Safety relay commanded off
496	Internal error: Unknown safety error occurred
497	Internal error: Safety timer was corrupt
498	Internal error: Safety timer was expired
499	Internal error: Safety timings
500	Internal error: Safety shutdown
550	Delta T inlet/outlet limit was exceeded
553	Inlet/outlet inversion occurred
564	Outlet T-rise limit was exceeded
600	Delta T inlet temperature was invalid
601	Delta T outlet temperature was invalid
603	CH ODR boost max offpoint temperature was invalid
604	CH ODR boost max offpoint temperature was too low
605	Lead Lag ODR boost max offpoint temperature was invalid
606	Lead Lag ODR boost max offpoint temperature was too low
609	Time to rotate lead boiler to next firing slave
610	Time to rotate lead boiler to next available slave
611	Time to rotate lead boiler to first firing slave in order
612	Time to rotate lead boiler to lowest running slave
613	Lead boiler was rotated based on new firing sequence order
614	Lead boiler was rotated based on measured run time

**Table 15-4 Alert Codes**

Code	Description
615	Parameter PCB was switched to backup
616	Range PCB was switched to backup
622	Lead Lag modulation sensor was not valid with setpoint source
623	Lead Lag modulation sensor was not valid with local setpoint source
624	Lead Lag modulation sensor was not valid with local modulation rate source
629	Disagreement on number of interacting controls

**16.0 PARTS LIST**

For a list of parts that corresponds to the item numbers in the callouts, refer to Table 16-1. Note that some item numbers may appear more than once in the parts list depending on which model number is being referenced.

**Building Owners** - Replacement parts are available from your stocking wholesaler. Contact your local Installer or Wholesaler for assistance with parts.

**Wholesalers** - Contact Slant/Fin inside sales department when ordering replacement parts at 1-516-484-2600.

**Installers** - Contact Slant/Fin tech support department if technical assistance required at 1-516-484-2600.

**Figure 16-1(a) CHS 85-110 Heat Engine and Gas Train**

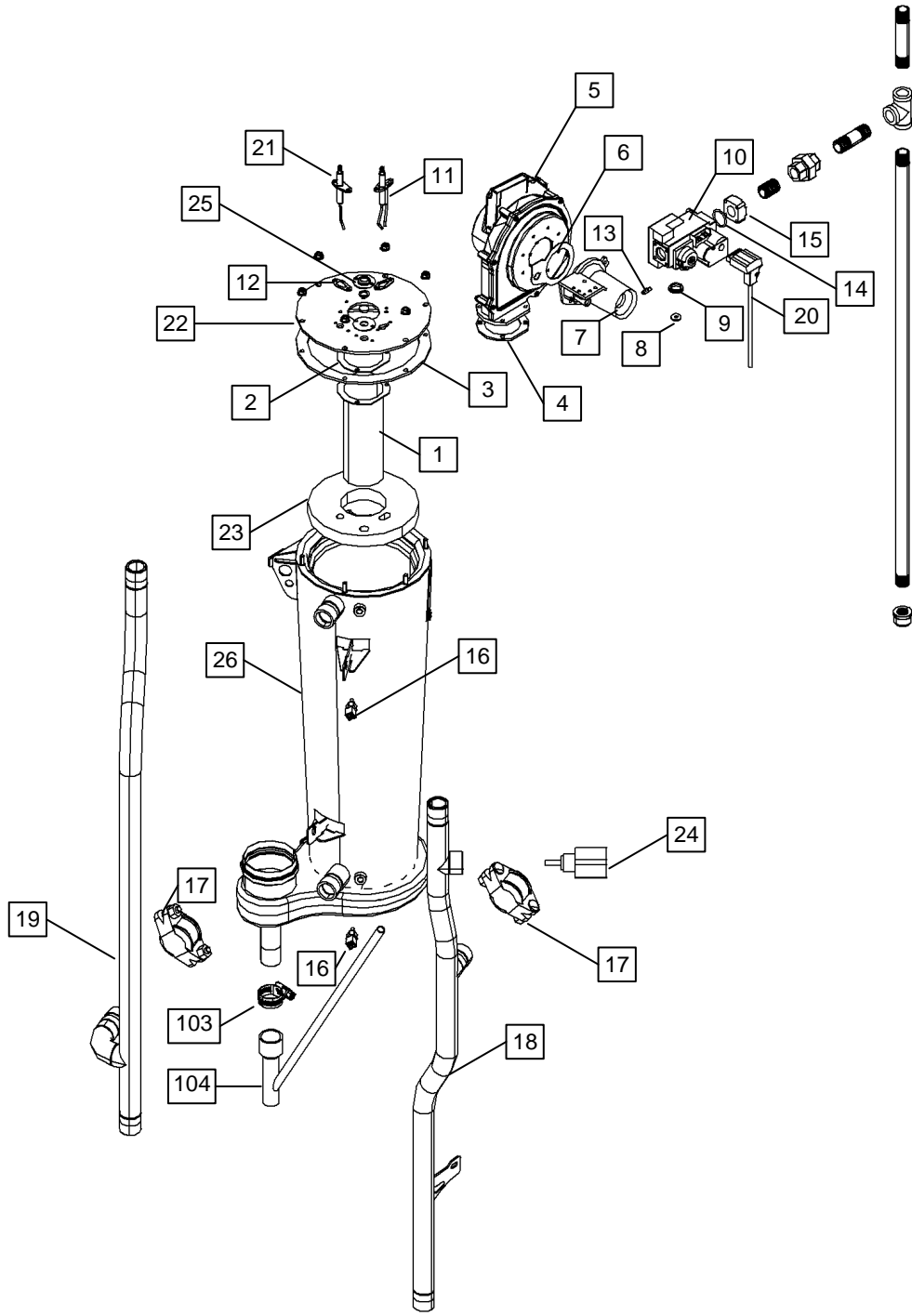

Figure 16-1(b) CHS-154 & CHS-201 Heat Engine and Gas Train (CHS-154 Illustrated)

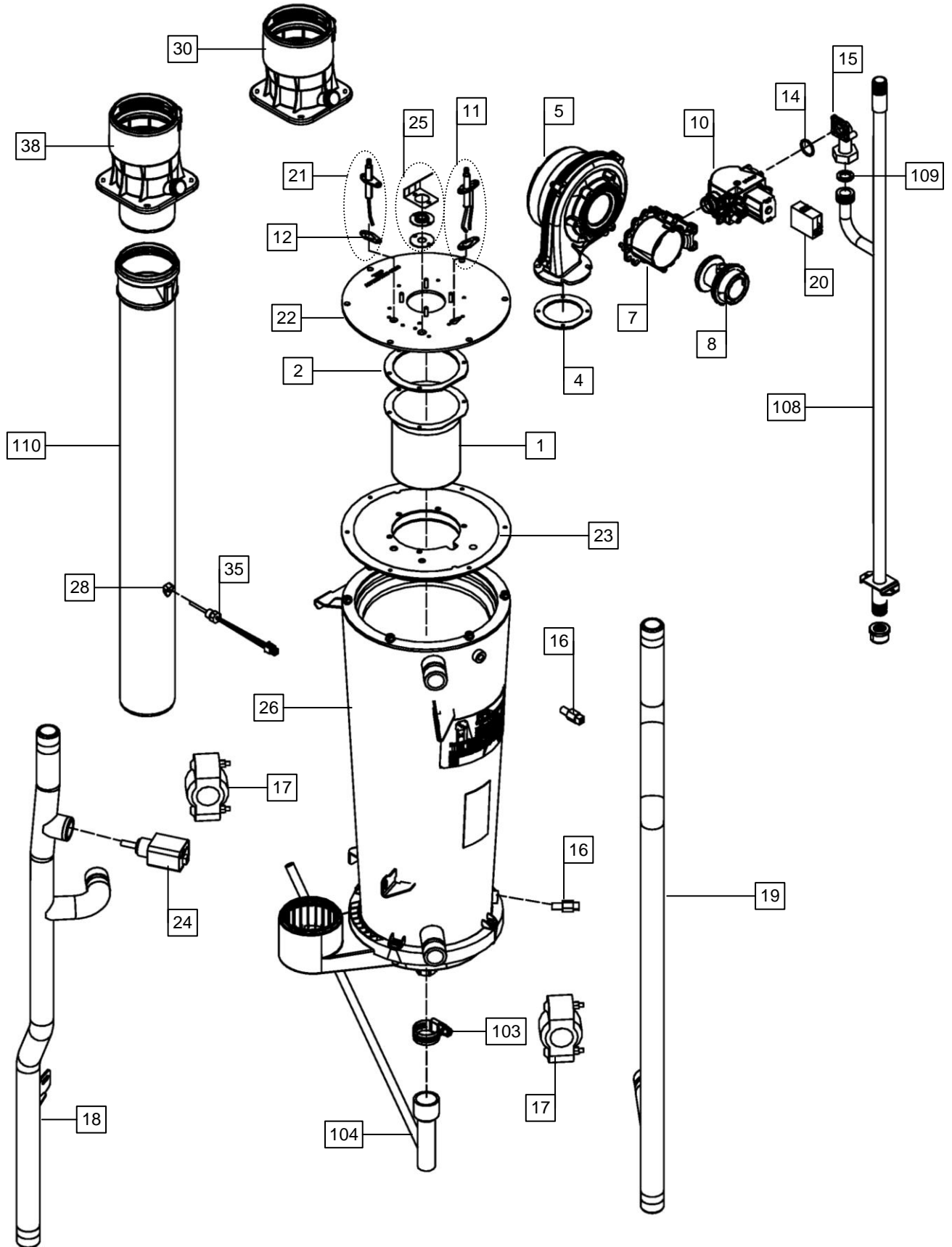

Figure 16-1(c) CHS 285-399 Heat Engine and Gas Train (CHS 340-399 Illustrated)

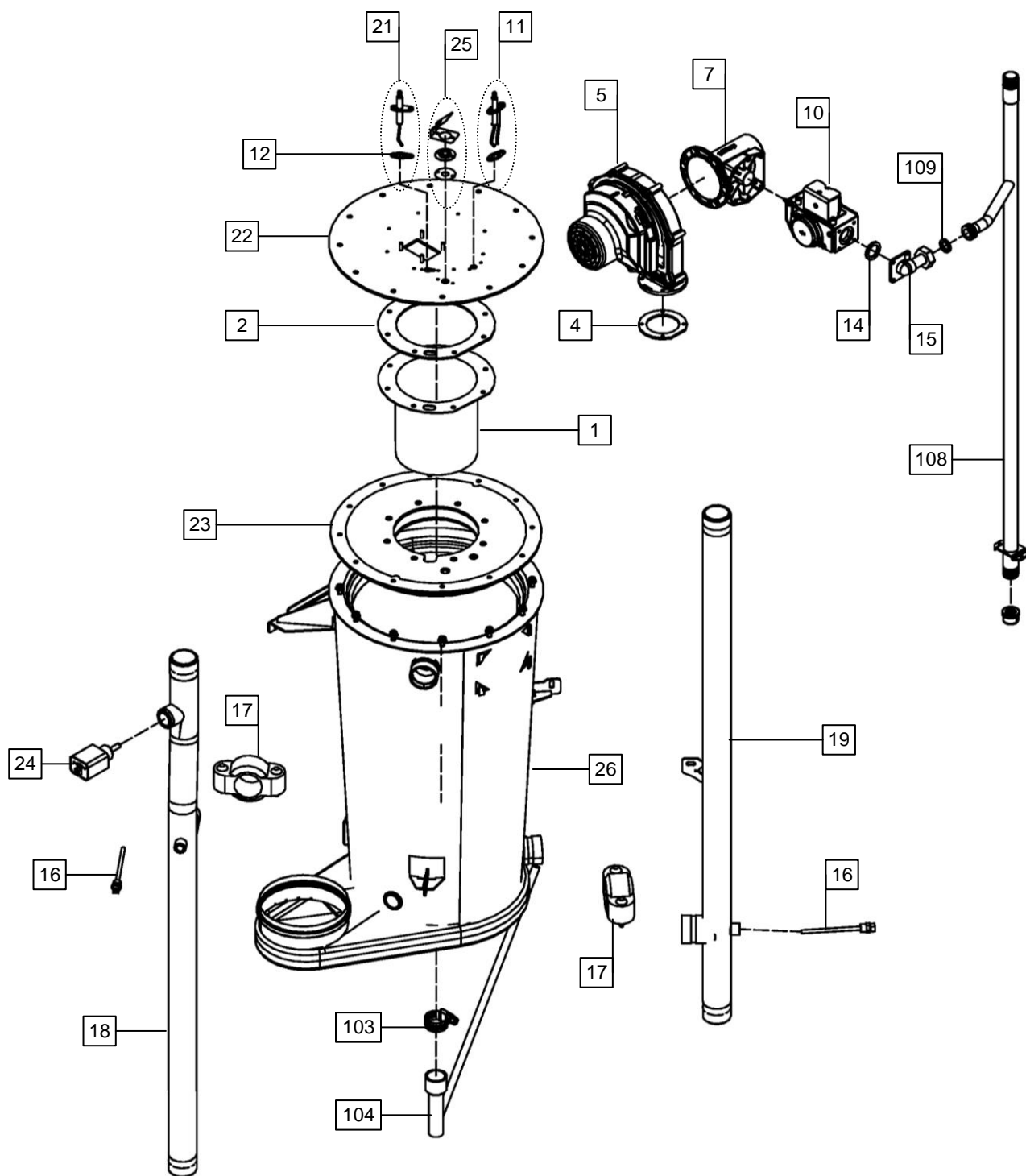



Figure 16-1(d) CHS Cabinet, Vent and Air-inlet Parts (CHS 85-110 Illustrated)

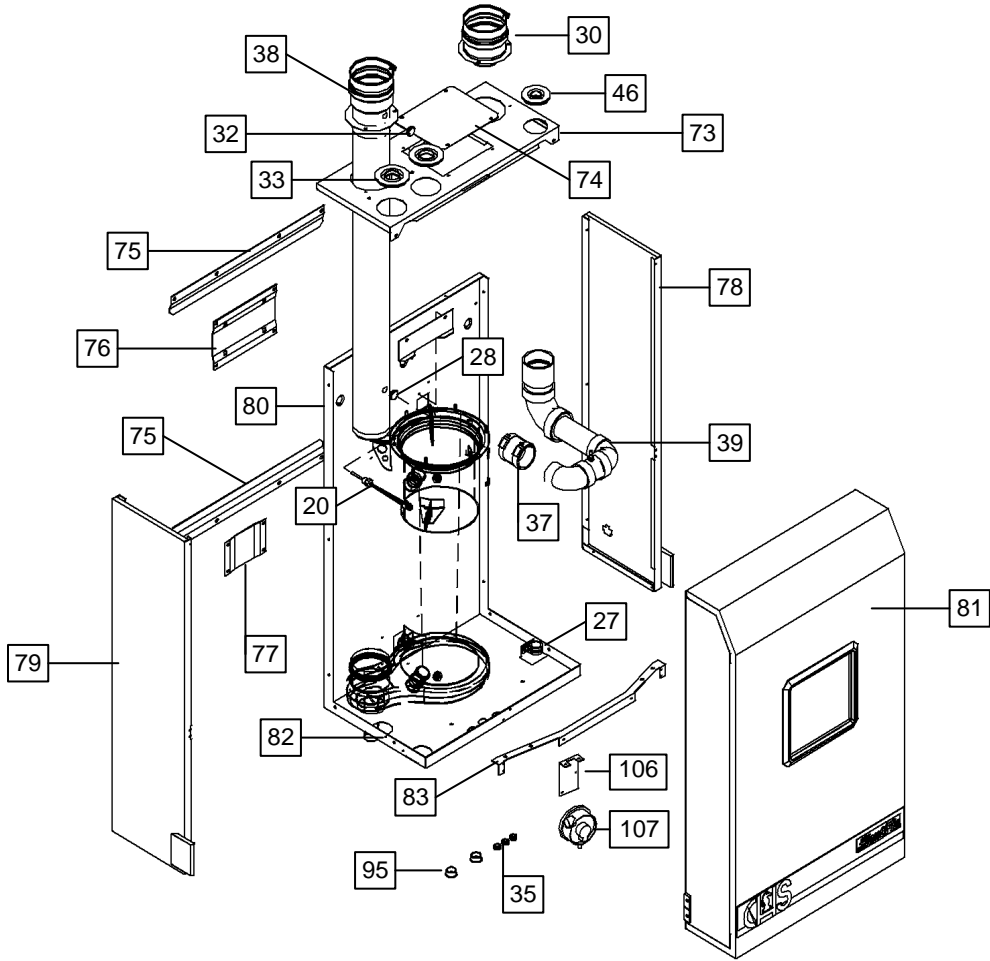

Figure 16-1(3) CHS Control Panel

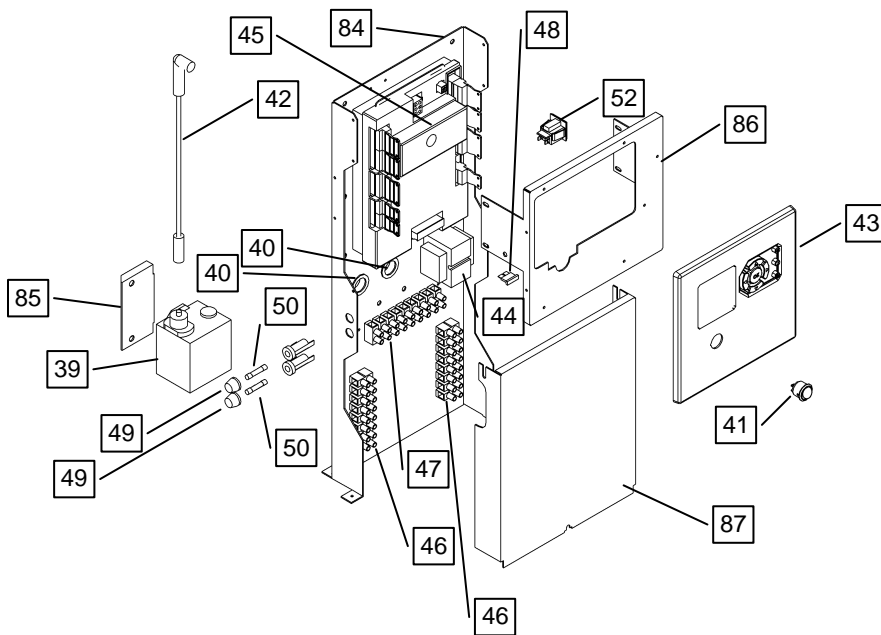

Figure 16-1(f) CHS Installation Kit

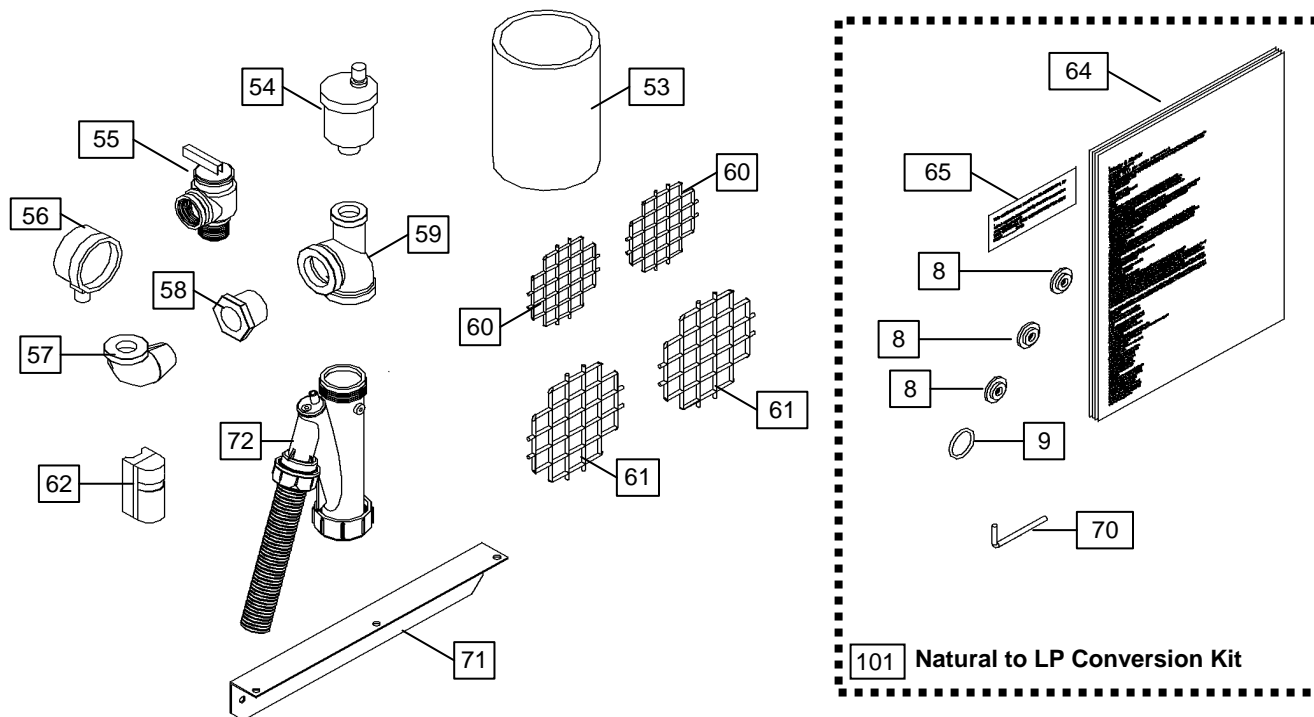

Table 16-1 Parts List:

Item	Model	Part No.	Description
1	CHS 85-110	81 8010 000	Premix Burner CHS 85-110
1	CHS 154, CHS 201	81 8240 000	Premix Burner CHS 154
1	CHS 155, CHS 175, CHS 200, CHS 250, CHS 285	81 8011 000	Premix Burner CHS 155-250
1	CHS 300-399	81 8012 000	Premix burner CHS 300-399
2	CHS 85-110	81 8013 000	Premix Burner Gasket CHS 85-110
2	CHS 154-285	81 8014 000	Premix Burner Gasket CHS 154-250
2	CHS 300-399	81 8015 000	Premix Burner Gasket CHS 300-399
3	CHS 85-110	81 8064 000	Burner Plate Gasket CHS 85-110
3	CHS 155-285	81 8065 000	Burner Plate Gasket CHS 155-250
3	CHS 300-399 (pre s/n 84200)	81 8066 000	Burner Plate Gasket CHS 300-399
4	CHS 85-399	81 8016 000	Blower Gasket CHS 85-399
5	CHS 85-110	81 8017 000	Combustion Blower RG130, CHS 85-110
5	CHS 154, CHS 201	81 8241 000	Combustion Blower, NRV118, CHS 154
5	CHS 155, CHS 175, CHS 200, CHS 250	81 8018 000	Combustion Blower RG148, CHS 155-250
5	CHS 285-399	81 8019 000	Combustion Blower RG148 Enhanced, CHS 300-399
6	CHS 85, CHS 110, CHS 155, CHS 175, CHS 200, CHS 250	81 8021 000	Venturi Gasket, Cork CHS 85-250
6	CHS 285-399	81 8020 000	Venturi to Blower O-ring CHS 300-399
7	CHS 85	81 8022 000	Venturi 003, CHS 85
7	CHS 110	81 8023 000	Venturi 002, CHS 110
7	CHS 154, CHS 201	81 8242 000	Venturi Housing (w/o Venturi Insert)
7	CHS 155, CHS 175, CHS 200, CHS 250	81 8024 000	Venturi 051, CHS 155-250
7	CHS 285	81 8295 000	Venturi 21.8, CHS 285
7	CHS 300-399 (pre s/n 84200)	81 8025 000	Venturi 45900450-010, CHS 300-399
7	CHS 340-399 (post s/n 95974)	81 8243 000	Venturi 28.1, CHS 340-399

Item	Model	Part No.	Description
8	CHS 154	81 8244 000	NG-Venturi Insert
8	CHS 154	81 8245 000	LP-Venturi Insert
8	CHS 201	81 8296 000	NG-Venturi Insert
8	CHS 201	81 8294 000	LP-Venturi Insert
8	CHS 85	81 8028 000	Gas Valve LP Orifice 4.15mm CHS 85
8	CHS 110	81 8026 000	Gas Valve LP Orifice 5.2mm CHS 110
8	CHS 155, CHS 175, CHS 200, CHS 250	81 8027 000	Gas Valve LP Orifice 6.2mm CHS 155-250
8	CHS 285	81 8297 000	Gas Valve Orifice 5.2mm, LP
8	CHS 300-399 (LP) (pre s/n 84200)	81 8030 000	Gas Valve LP Orifice 7.4mm CHS 300-399
8	CHS 300-399 (NG) (pre s/n 84200)	81 8029 000	Gas Valve NG Orifice 9.6mm CHS 300-399
8	CHS 340-399 (LP) (post s/n 95974)	81 8246 000	Gas Valve Orifice 6.75 mm, LP
9	CHS 300-399 (pre s/n 84200)	81 8144 000	Gas Valve Orifice O-Ring CHS 300-399
9	CHS 285, CHS 340-399 (post s/n 95974)	81 8247 000	Gas Valve to Venturi Gasket CHS 340-399
9	CHS 85-110, CHS 155, CHS 175, CHS 200, CHS 250	81 8143 000	Gas Valve to Venturi Screws/Seals CHS 85-110, 155-250
9	CHS 154, CHS 201	81 8248 000	Gas Valve to Venturi Gasket CHS 154
10	CHS 85-110, CHS 155, CHS 175, CHS 200, CHS 250	81 8032 000	Gas Valve VK8115V1341B (Valve Only)
10	CHS 154, CHS 201	81 8249 000	Gas Valve GB 055
10	CHS 300-399 (pre s/n 84200)	81 8031 000	Gas Valve VR8615VB 1044B
10	CHS 285, CHS 340-399 (post s/n 95974)	81 8250 000	Gas Valve GB 057
11	CHS 85-399	81 8033 000	Ignition Electrode, Dual – c/w gasket, gap = 3/16 to 1/4”
12	CHS 85-399	81 8034 000	Igniter Gasket, Graphite (Ignition Electrode / Flame Rod)
13	CHS 85-110, CHS 155, CHS 175, CHS 200, CHS 250	81 8035 000	Gas Valve Regulator Vent Adapter
14	CHS 85-110, CHS 155, CHS 175, CHS 200, CHS 250	81 8037 000	Gas Valve Inlet O-ring Gasket CHS 85-250
14	CHS 154, CHS 201	81 8298 000	Gas Valve Inlet O-ring Gasket CHS 154
14	CHS 285-399	81 8036 000	Gas Valve Inlet O-ring Gasket CHS 300-399
15	CHS 85-110, CHS 155, CHS 175, CHS 200, CHS 250	81 8039 000	Gas Valve ½” NPT adapter CHS 85-250
15	CHS 154, CHS 201	81 8299 000	Gas Valve ½” NPT adapter CHS 154
15	CHS 285-399	81 8038 000	Gas Valve ¾” NPT adapter CHS 300-399
16	CHS 85-285	81 8041 000	Sensor, Supply & Return, Dual CHS 85-250
16	CHS 300-399	81 8040 000	Sensor, Supply & Return, Dual CHS 300-399
17	CHS 85-154	81 8043 000	Pipe Coupling, Groove-Joint, 1” CHS 85-110
17	CHS 155-285	81 8044 000	Pipe Coupling, Groove-Joint, 1 ¼” CHS 155-250
17	CHS 300-399	81 8045 000	Pipe Coupling, Groove-Joint, 1 ½” CHS 300-399
18	CHS 85-110	81 8046 000	Supply Pipe, SS, 1”
18	CHS 154	81 8251 000	Supply Pipe, SS, 1”
18	CHS 155-250	81 8047 000	Supply Pipe, SS, 1 ¼”
18	CHS 285	81 8300 000	Supply Pipe, SS, 1 ¼”
18	CHS 300-399	81 8048 000	Supply Pipe, SS, 1 ½”
19	CHS 85-110	81 8051 000	Return Pipe, SS, 1”
19	CHS 154	81 8252 000	Return Pipe, SS, 1”
19	CHS 155-250	81 8052 000	Return Pipe, SS, 1 ¼”
19	CHS 285	81 8301 000	Return Pipe, SS, 1 ¼”
19	CHS 300-399	81 8053 000	Return Pipe, SS, 1 ½”
20	CHS 85-110, CHS 155, CHS 175, CHS 200, CHS 250	81 8158 000	Gas Valve Harness CHS 85-110, 155-250
20	CHS 154	81 8253 000	Gas Valve Rectifier Box

Item	Model	Part No.	Description
20	CHS 201	81 8302 000	Gas Valve Rectifier Box Kit
20	CHS 300-399 (pre s/n 84200)	81 8159 000	Gas Valve Harness CHS 300-399
20	CHS 285, CHS 340-399 (post s/n 95974)	81 8254 000	Gas Valve Harness CHS 340-399
21	CHS 85-399	81 8074 000	Flame Rod CHS 85-399 (Includes gasket)
22	CHS 85-110	81 8070 000	Burner Plate CHS 85-110
22	CHS 154	81 8255 000	Burner Plate CHS 154
22	CHS 155-285	81 8071 000	Burner Plate CHS 155-250
22	CHS 300-399 (pre s/n 84200)	81 8072 000	Burner Plate CHS 300-399
22	CHS 340-399 (post s/n 95974)	81 8256 000	Burner Plate CHS 340-399
23	CHS 85-110	81 8067 000	Burner Plate Ceramic Disc CHS 85-110
23	CHS 154	81 8257 000	Burner Plate Insulation & Gasket
23	CHS 155-285	81 8068 000	Burner Plate Ceramic Disc CHS 155-250
23	CHS 300-399 (pre s/n 84200)	81 8069 000	Burner Plate Ceramic Disc CHS 300-399
23	CHS 340-399 (post s/n 95974)	81 8258 000	Burner Plate Insulation & Gasket
24	CHS 85-399	81 8042 000	Low Water Cutoff
25	CHS 85-399	81 8055 000	Sight Glass Assembly
26	CHS 85-110	81 8056 000	Heat Exchanger-ASME CHS 85-110
26	CHS 154	81 8259 000	Heat Exchanger-ASME CHS 154
26	CHS 201	81 8303 000	Heat Exchanger-ASME CHS 201
26	CHS 155, CHS 175, CHS 200, CHS 250, CHS 285	81 8057 000	Heat Exchanger-ASME CHS 155-250
26	CHS 340	81 8260 000	Heat Exchanger-ASME CHS 340
26	CHS 300, 399	81 8058 000	Heat Exchanger-ASME CHS 300, 399
27	CHS 85-250	81 8059 000	Tube Strap CHS 85-250
27	CHS 285-399	81 8060 000	Tube Strap CHS 300-399
28	CHS 85-110, CHS 155-399	81 8061 000	Flue Sensor Grommet (3009354)
28	CHS 154	81 8261 000	Flue Sensor Grommet
29	CHS 85-399	81 8073 000	Grommet, Diaphragm, 1/2"
30	CHS 85-110, CHS 155-285	81 8084 000	Air-inlet Adapter, SS, 3" CHS 85-250
30	CHS 154	81 8262 000	Air-inlet Adapter, PP, 3" CHS 154
30	CHS 300-399	81 8085 000	Air-inlet Adapter, SS, 4" CHS 300-399
31	CHS 85-399	81 8156 000	Dome Plug, Black, 7/8"
32	CHS 85-110, CHS 155-399	81 8086 000	Flue Adapter Test Port Plug, 12mm
33	CHS 85-110	81 8091 000	Grommet, Vinyl, 1" IPS (1300) CHS 85-110
33	CHS 155-285	81 8092 000	Grommet, Vinyl, 1-1/4" IPS (1625) CHS 155-250
33	CHS 300-399	81 8093 000	Grommet, Vinyl, 1-1/2" IPS (1875) CHS 300-399
34	CHS 85-250	81 8089 000	Grommet, Vinyl, 1/2" IPS (1020-T) CHS 85-250
34	CHS 285-399	81 8090 000	Grommet, Vinyl, 3/4" IPS (1020) CHS 300-399
35	CHS 85-399	81 8050 000	Flue Sensor, Dual
36	CHS 85-250	81 8075 000	1 1/2" MJ Coupling CHS 85-250
36	CHS 285-399	81 8076 000	2" MJ Coupling CHS 300-399
37	CHS 85-110	81 8078 000	Air-inlet Assembly CHS 85-110
37	CHS 154	81 8304 000	Air-inlet Assembly CHS 154
37	CHS 155, CHS 175, CHS 200, CHS 250	81 8079 000	Air-inlet Assembly CHS 155-250
37	CHS 201	81 8305 000	Air-inlet Assembly CHS 201
37	CHS 285	81 8306 000	Air-inlet Assembly CHS 285
37	CHS 300-399	81 8080 000	Air-inlet Assembly CHS 300-399
38	CHS 85-110	81 8081 000	Flue Outlet Adapter, SS, 3" CHS 85-110
38	CHS 154	81 8263 000	Flue Outlet Adapter PP 3" CHS 154

Item	Model	Part No.	Description
38	CHS 155-285	81 8082 000	Flue Outlet Adapter, SS, 3" CHS 155-250
38	CHS 300-399	81 8083 000	Flue Outlet Adapter, SS, 4" CHS 300-399
39	CHS 85-399	81 8111 000	Ignition Coil
40	CHS 85-399	81 8113 000	Snap Bushing, 1"
41	CHS 85-399	81 8160 000	Round Rocker Switch, On-Off (LCD Dot-Matrix Display)
42	CHS 85-399	81 8112 000	Spark Igniter Wire, 12"
43	CHS 85-399	81 8095 000	User Interface (LCD Dot-Matrix Display)
44	CHS 85-399	81 8114 000	Transformer, 24V, 40VA
45	CHS 85-399	81 8115 000	Controller, CHS series
46	CHS 85-399	81 8097 000	Terminal, Barrier, 2 Row, 8 Position
47	CHS 85-399	81 8118 000	Terminal, Barrier, 2 Row, 9 Position
48	CHS 85-399	81 8119 000	Fuse, 2A, 32V, Plug Style
49	CHS 85-399	81 8120 000	Fuse Holder, Panel Mount, 20 Amp at 250VAC Max
50	CHS 85-399	81 8121 000	Fuse, 7A, 250VAC, Fast-Acting
52	CHS 85-399	81 8054 000	Receptacle, 120VAC
53	CHS 85-285	81 8161 000	3" CPVC Pipe, System 636, 5" long CHS 85-250
53	CHS 300-399	81 8161 000	4" CPVC Pipe, System 636, 5" long CHS 300-399
54	CHS 85-399	81 8049 000	Auto Air Vent, 1/2" NPT
55	CHS 85-399	81 8163 000	Pressure Relief Valve, ASME, 3/4" NPT, 30psi
56	CHS 85-399	81 8164 000	Pressure Gauge, 0-60psi
57	CHS 85-399	81 8063 000	Brass Elbow, 90, Street, 3/4"
58	CHS 85-110	81 8150 000	Brass Bushing, 1" x 3/4" CHS 85-110
58	CHS 155-285	81 8151 000	Brass Bushing, 1 1/4" x 3/4" CHS 155-250
58	CHS 300-399	81 8152 000	Brass Bushing, 1 1/2" x 3/4" CHS 300-399
59	CHS 85-110	81 8153 000	Brass Tee, 1" x 1/2" x 1" CHS 85-110
59	CHS 155-285	81 8154 000	Brass Tee, 1 1/4" x 1/2" x 1 1/4" CHS 155-250
59	CHS 300-399	81 8155 000	Brass Tee, 1 1/2" x 1/2" x 1 1/2" CHS 300-399
60	CHS 85-110	81 8077 000	2" Round Mesh Vent Screen CHS 85-110
61	CHS 85-285	81 8165 000	3" Round Mesh Vent Screen CHS 85-250
61	CHS 300-399	81 8166 000	4" Round Mesh Vent Screen CHS 300-399
62	CHS 85-399	81 8126 000	Outdoor Sensor, 10K
63	CHS 85-399	81 8146 000	System Sensor, 10K (Optional)
64	CHS 85-110, CHS 155, CHS 175, CHS 200, CHS 250	81 8167 000	Natural Gas to LP Conversion Instructions CHS 85-110, 155-250
64	CHS 154	81 8264 000	Natural Gas to LP Conversion Instructions CHS 154
64	CHS 201	81 8292 000	Natural Gas to LP Conversion Instructions CHS 201
64	CHS 285	81 8293 000	Natural Gas to LP Conversion Instructions CHS 285
64	CHS 300-399 (pre s/n 84200)	81 8168 000	Natural Gas to LP Conversion Instructions CHS 300-399
64	CHS 340-399 (post s/n 95974)	81 8265 000	Natural Gas to LP Conversion Instructions CHS 340-399
65	CHS 85-110, CHS 155, CHS 175, CHS 200, CHS 250	81 8169 000	Conversion Decal CHS 85-110, 155-250
65	CHS 154	81 8266 000	Conversion Decal CHS 154
65	CHS 201	81 8309 000	Conversion Decal CHS 201
65	CHS 285	81 8310 000	Conversion Decal CHS 285
65	CHS 300-399 (pre s/n 84200)	81 8170 000	Conversion Decal CHS 300-399
65	CHS 340-399 (post s/n 95974)	81 8267 000	Conversion Decal CHS 340-399
71	CHS 85-399	81 8094 000	Wall Mount Bracket Bottom CHS 85-399
72	CHS 85-399 (pre s/n 16135 and post s/n 119299)	81 8062 000	Condensate Trap (pre s/n 16135 and post s/n 119299)
72	CHS 85-399 (s/n 16135 to 119299)	81 8323 000	Condensate Trap Retrofit Kit (s/n 16135 to 119299)
73	CHS 85-110	81 8138 000	Top Panel CHS 85-110
73	CHS 154	81 8268 000	Top Panel CHS 154
73	CHS 201	81 8311 000	Top Panel CHS 201

Item	Model	Part No.	Description
73	CHS 155, CHS 175, CHS 200, CHS 250	81 8139 000	Top Panel CHS 155-250
73	CHS 285	81 8312 000	Top Panel CHS 285
73	CHS 300-399 (pre s/n 84200)	81 8140 000	Top Panel CHS 300-399
73	CHS 340-399 (post s/n 95974)	81 8269 000	Top Panel CHS 340-399
74	CHS 85-110	81 8135 000	Top Panel Access Cover CHS 85-110
74	CHS 154	81 8270 000	Top Panel Access Cover CHS 154
74	CHS 155-250	81 8136 000	Top Panel Access Cover CHS 155-250
74	CHS 285	81 8313 000	Top Panel Access Cover CHS 285
74	CHS 300-399 (pre s/n 84200)	81 8137 000	Top Panel Access Cover CHS 300-399
74	CHS 340-399 (post s/n 95974)	81 8271 000	Top Panel Access Cover CHS 340-399
75	CHS 85-285	81 8087 000	Wall Mount Bracket Top, Galvanized CHS 85-250
75	CHS 300-399	81 8088 000	Wall Mount Bracket Top, Galvanized CHS 300-399
76	CHS 85-399	81 8142 000	Top Heat Exchanger Support, Galvanized
77	CHS 85-399	81 8141 000	Bottom Heat Exchanger Support, Galvanized
78	CHS 85-110	81 8129 000	Right Side CHS 85-110
78	CHS 154-250	81 8130 000	Right Side CHS 154-250
78	CHS 285	81 8314 000	Right Side CHS 285
78	CHS 300-399	81 8131 000	Right Side CHS 300-399
79	CHS 85-110	81 8132 000	Left Side CHS 85-110
79	CHS 154-250	81 8133 000	Left Side CHS 155-250
79	CHS 285	81 8315 000	Left Side CHS 285
79	CHS 300-399	81 8134 000	Left Side CHS 300-399
80	CHS 85-110	81 8145 000	Back/Bottom, Galvanized CHS 85-110
80	CHS 154	81 8272 000	Back, Galvanized CHS 154
80	CHS 155, CHS 175, CHS 200, CHS 250	81 8273 000	Back, Galvanized CHS 155-250
80	CHS 201	81 8316 000	Back, Galvanized CHS 201
80	CHS 285	81 8317 000	Back, Galvanized
80	CHS 300-399 (pre s/n 84200)	81 8274 000	Back, Galvanized CHS 300-399
80	CHS 340-399 (post s/n 95974)	81 8275 000	Back, Galvanized CHS 340-399
81	CHS 85-250	81 8127 000	Front Cover CHS 85-250
81	CHS 285	81 8318 000	Front Cover CHS 285
81	CHS 300-399	81 8128 000	Front Cover CHS 300-399
82	CHS 154	81 8276 000	Bottom, Galvanized CHS 154
82	CHS 155, CHS 175, CHS 200, CHS 250	81 8147 000	Bottom, Galvanized CHS 155-250
82	CHS 201	81 8319 000	Bottom, Galvanized CHS 201
82	CHS 285	81 8320 000	Bottom, Galvanized CHS 285
82	CHS 300-399 (pre s/n 84200)	81 8148 000	Bottom, Galvanized CHS 300-399
82	CHS 340-399 (post s/n 95974)	81 8277 000	Bottom, Galvanized CHS 340-399
83	CHS 85-110	81 8098 000	Control Panel Support, Galvanized CHS 85-110
83	CHS 154	81 8322 000	Control Panel Support, Galvanized CHS 154
83	CHS 155-250	81 8099 000	Control Panel Support, Galvanized CHS 155-250
83	CHS 285	81 8321 000	Control Panel Support, Galvanized CHS 285
83	CHS 300-399	81 8110 000	Control Panel Support, Galvanized CHS 300-399
84	CHS 85-399	81 8117 000	Control Panel Base, Galvanized
85	CHS 85-399	81 8149 000	Spark Generator Support Bracket, Galvanized
86	CHS 85-399	81 8122 000	User Interface Mounting Support (Bracket), CHS 85-399
87	CHS 85-399	81 8116 000	Control Panel Cover, Galvanized
88	CHS 85-399	81 8171 000	Fire Tube Floor Stand
89	CHS 85-285	81 8172 000	3" Low Profile Vent Terminal CHS 85-285
90	CHS 85-285	81 8173 000	3" Concentric Vent Terminal CHS 85-285

Item	Model	Part No.	Description
91	CHS 300-399	81 8174 000	4" Low Profile Vent Terminal CHS 300-399
92	CHS 300-399	81 8175 000	4" Concentric Vent Terminal CHS 300-399
93	CHS 85-399	81 8176 000	DHW Tank Sensor
94	CHS 85-399	81 8146 000	System / Pipe Sensor
95	CHS 85-250	81 8103 000	CHS 85-250 Tool Box
96	CHS 300-399 (pre s/n 84200)	81 8104 000	CHS 300-399 Tool Box
97	CHS 85-399	81 8179 000	Fernox Test strips
98	CHS 85-399	81 8180 000	Fernox F1 protector (CHP-500ml)
99	CHS 85-399	81 8181 000	Fernox F3 Cleaner (CHR-500ml)
100	CHS 85-399	81 8182 000	Fernox DS-40 (DS-40 descaler)
101	CHS 85-110, CHS 155, CHS 175, CHS 200, CHS 250	81 8124 000	Natural Gas to LP Conversion Kit CHS 85-110, 155-250
101	CHS 154	81 8278 000	Natural Gas to LP Conversion Kit CHS 154
101	CHS 201	81 8292 000	Natural Gas to LP Conversion Kit CHS 200
101	CHS 285	81 8293 000	Natural Gas to LP Conversion Kit CHS 285
101	CHS 300-399 (pre s/n 84200)	81 8125 000	Natural Gas to LP Conversion Kit CHS 300-399
101	CHS 340-399 (post s/n 95974)	81 8279 000	Natural Gas to LP Conversion Kit CHS 340-399
103	CHS 85-399	81 8230 000	Hose Clamp, 1-1/16 to 1-1/2"
104	CHS 85-399 (post s/n 119299)	81 8324 000	Condensate Drain Adapter Tube (post s/n 119299)
104	CHS 85-399 (s/n 16135 to 119299)	81 8323 000	Condensate Drain Retrofit Kit (s/n 16135 to 119299)
105	CHS 85-399	81 8231 000	Hose Clamp, 9/16 to 1-1/16"
106	CHS 85-399		Air Switch Bracket
107	CHS 85-399	81 8221 000	Blocked Condensate Drain / Blocked Vent Switch
108	CHS 154, CHS 201	81 8280 000	Gas Supply Manifold
108	CHS 340-399 (post s/n 95974)	81 8281 000	Gas Supply Manifold
109	CHS 154, CHS 201		Gasket, Gas Line
110	CHS 154	81 8282 000	Flue Outlet Pipe PP 3"



©Slant/Fin Corp. 2018 • 618 • PUBLICATION CHS-40

---

SLANT/FIN CORPORATION, Greenvale, N.Y. 11548 • Phone: (516) 484-2600  
FAX: (516) 484-5921 • Canada: Slant/Fin LTD/LTEE, Mississauga, Ontario

[www.slantfin.com](http://www.slantfin.com)