



STREBEL MITAL & STREBEL MONTREUX

Fan Assisted Wall Mounted Gas
Combination
&
System Boilers

**USER, INSTALLATION,
COMMISSIONING & MAINTENANCE
INSTRUCTIONS.**

Contents

		<u>Page No.</u>
1.0	Introduction -----	3
2.0	General Precautions -----	3
3.0	Installation -----	3
3.1	Reference Regulations -----	3
3.2	Packaging -----	3
3.3	Boiler Location -----	3
4.0	Technical Data -----	4
5.0	Ventilation -----	6
6.0	Flueing -----	6
7.0	Boiler Siting -----	8
8.0	Flue Assembly -----	8
9.0	Flue & Boiler Accessories -----	9
10.0	Gas Supply -----	10
10.1	L.P.G. Conversion -----	10
11.0	Cold Water Supply (Mital, Mital plus & Mital max only) -----	10
12.0	Sealed Primary System -----	11
13.0	Electrical System -----	12
13.1	Internal wiring -----	12
13.2	External Controls -----	12
14.0	Commissioning -----	17
14.1	Handing Over -----	18
15.0	Maintenance -----	19
15.1	Fault Finding -----	19
15.2	Fault Finding Guide -----	20
16.0	Users Instructions -----	21

Illustrations:

Figure 1. Boiler Dimensions & Clearances	Figure 14. Montreux Internal Wiring Diagram
Figure 2. Air Vent Positions	Figure 15. Mital plus Internal Wiring Diagram
Figure 3. Flue Terminal Position	Figure 16. Montreux plus & max Internal Wiring Diagrams
Figure 4. Boiler & Manifold Fixing Points	Figure 17. Mital max Internal Wiring Diagrams
Figure 5. Manifold Assembly	Figure 18. Honeywell V4600 Gas Valve
Figure 6. Flue Adapters	Figure 19. SIT 826 Nova Gas Valve
Figure 7. Coaxial Flue System	Figure 20. SIT 826 Nova Gas Valve, High and Low Gas Pressure Adjustment.
Figure 8. Twin Pipe Flue System	Figure 21. Burner Fixing Screws.
Figure 9. Boiler Flue Gate	Figure 22. Mital & Montreux Control Panel
Figure 10. CWS Flow Valve	Figure 23. Mital plus, Mital max, Montreux plus & Montreux max Control Panel
Figure 11. HWS Flow / Temp Graph	
Figure 12a - d. Resistance & Pump Diagram	
Figure 13. Mital Internal Wiring Diagram	

1.0 Introduction

Thank you for choosing our products. We recommend that these instructions be used to ensure the safe operation of the boiler and to maximise their performance.

The data plate for the boilers is located behind the control panel cover.

Boiler names:

Mital - wall hung gas-fired combination boiler with fan assisted flue; output 23.2 kW.

Mital plus - room sealed wall hung gas-fired combination boiler with fan assisted flue and electronic ignition; output 23.2 kW.

Mital max - room sealed wall hung gas fired combination boiler with fan assisted flue and electronic ignition; output 31.3kW.

Montreux - wall hung gas-fired system boiler with fan assisted flue; output 23.2 kW.

Montreux plus - room sealed wall hung gas-fired system boiler with fan assisted flue and electronic ignition; output 23.2 kW.

Montreux max - room sealed wall hung gas-fired system boiler with fan assisted flue and electronic ignition; output 31.3 kW.

2.0 General Precautions

- This instruction manual is an integral and essential part of the appliance, and must be left with the end user and stored near to the boiler for further consultation during maintenance etc.
- These instructions must be read thoroughly before proceeding, failure to follow the instructions may affect the safety, performance and warranty of the appliance.
- Installation must be carried out by professional, qualified **CORGI REGISTERED ENGINEERS** in compliance with all current regulations and manufacturers instructions.
- The installation of the boiler must also be in accordance with the current I.E.E. Regulations, the By-laws of the Local Water Undertaking, Local Authority requirements and all relevant British Standards.
- The appliance must be installed in a suitable environment that is NOT explosive, flammable, corrosive or damp.
- Neither the supplier or the manufacturer will be responsible for any damage to property, persons, animals or the boiler, as a result of tampering, improper use, installation or maintenance.
- Packaging parts (i.e. plastic bags, polystyrene, wood, clips, nails, etc.) **can be harmful to children and must be disposed of immediately and correctly.**

- To avoid damage caused by low temperatures it is recommended that the boiler should be drained down if left unused for a long period. Neither the supplier or manufacturer is responsible for faults, break downs, water leakage or any consequential damage caused by low temperature.
- To comply with the Warranty these instructions must be adhered to and only original spare parts and kits used.
- In the event of breakdown the appliance should be isolated and a qualified **CORGI REGISTERED SERVICE ENGINEER** contacted.
- This appliance **MUST** have an annual service and inspection by a suitably qualified **CORGI REGISTERED ENGINEER**.

3.0 Installation

3.1 Reference Regulations

Detailed recommendations are contained in the following :

BS 5440 :1 & 2, BS 4543, BS 5540 :2, BS 6798, BS 5449, BS 5546, BS 6891, Gas Safety Regulations 1984. **All other relevant regulations must be adhered to whether they are listed above or not.**

3.2 Packaging

The packing material and the cardboard cover must be removed without turning the boiler upside down. **The boiler should be kept in a vertical position and on the polystyrene lower base. Never place the boiler directly onto the floor.**

To remove the cardboard cover open the base of the box and lift the box off the boiler.

Each boiler is supplied in three separate containers:

1. boiler
2. connection manifold, valves and angled connecting pipes.
3. flue kit

any extras or additions will be packed separately.

3.3 Boiler Location

Mital & Montreux - Both these appliances are NOT ROOM SEALED and therefore must **NOT** be installed in a bedroom, bedsitting room or any room containing a bath or a shower.

These boilers must be sited 0.5 metres from combustible materials i.e. curtains etc.

Mital plus, Mital max, Montreux plus & Montreux max are room sealed and can be installed in any room, although particular attention is drawn to the requirements of the IEE Regulations and, in Scotland, the electrical provisions with respect to the installation in a room containing a bath or shower.

If the boiler is to be installed in a room that contains a bath or shower the boiler MUST be

situated so that it cannot be touched while the person is using the bath or shower.

General

The wall must be flat and vertical, and of suitable load bearing capacity.

Adequate space must be allowed around the boiler to facilitate installation, servicing and maintenance, the required clearances are shown in figure 1.

The boiler MUST be positioned so the top of the boiler is a minimum of 2.2 metres from floor level or suitable provision made to restrict accidental access to the top of the boiler.

The position must permit a satisfactory flue terminal position.

4.0 Technical Data

Model		Combination Boilers			System Boilers		
		Mital	Mital plus	Mital max	Montreux	Montreux plus	Montreux max
Input	kW	13.2 - 26.4	13.2 - 26.4	17.4 - 34.8	13.2 - 26.4	13.2 - 26.4	17.4 - 34.8
Output	kW	11.6 - 23.2	11.6 - 23.2	15.6 - 31.3	11.6 - 23.2	11.6 - 23.2	15.6 - 31.3
DHW Flow Rate at 25°C Δt	Lt/min	13.3	13.3	17.9	--	--	--
Flue Size	mm	60	100	100	60	100	100
Electrical Supply		230 volts - 50 Hz - Single Phase					
Heating Circuit Pressure Bar	max	3	3	3	3	3	3
	min	0.5	0.5	0.5	0.5	0.5	0.5
DHW Circuit Pressure Bar	max	6	6	6	--	--	--
	min	0.4	0.4	0.4			
Dimensions (mm)	Height	850	850	850	850	850	850
	Width	450	450	600	450	450	600
	Depth	350	350	350	350	350	350
Clearances (mm)	Top	400	400	400	400	400	400
	Bottom	400	400	400	400	400	400
	Front	350	350	350	350	350	350
	Sides	25	25	25	25	25	25
Weight (empty)	kg	43	49	69	39	45	55
Features:	Fan Assisted	X	X	X	X	X	X
	Room Sealed	—	X	X	—	X	X
	Instantaneous DHW capability	X	X	X	—	—	—
	Built-in Pump (Circulating)	X	X	X	X	X	X
	Electronic Ignition	—	X	X	—	X	X
	Permanent Pilot	X	—	—	X	—	—
	Slow Start Burner	X	X	X	X	X	X
	Overheat Thermostat	X	X	X	X	X	X
	Safety Valve 3 Bar	X	X	X	X	X	X

Figure.1 - Boiler Dimensions & Clearances.

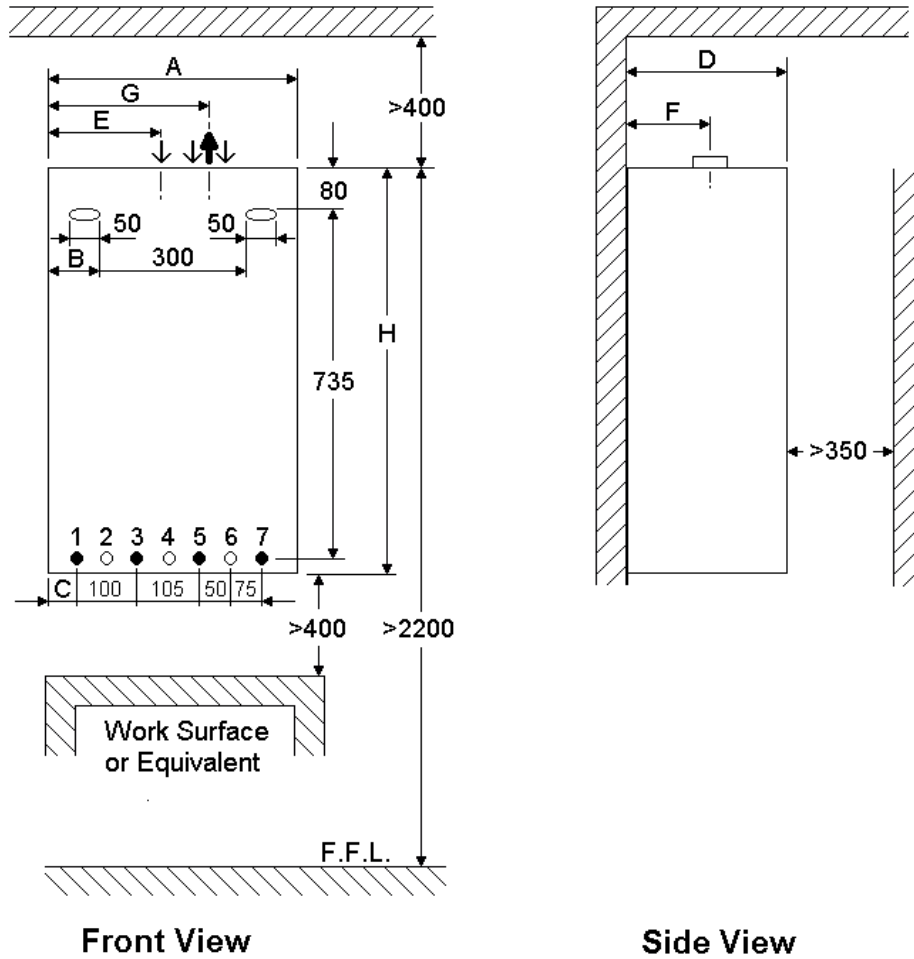

KEY

	Connections	(mm)
1	DHW outlet	15
2	Safety valve discharge	15
3	Gas supply	15
4	Electrical cables	--
5	Mains water inlet	15
6	Heating flow	22
7	Heating return	22

Clearances (mm)	Top	400
	Bottom	400
	Front	350
	Sides	25

DIMENSION		MODEL	Mital	Mital plus	Mital max	Montreux	Montreux plus	Montreux max
A	Width of Unit		450	450	600	450	450	600
B	Inside of fixing point		75	75	75	75	75	75
C	Centre of DHW connection		55	55	55	55	55	55
D	Depth of Unit		350	350	350	350	350	350
E	Centre of combustion air inlet *		--	155	200	--	155	200
F	Centre Exhaust outlet		195	195	185	195	195	185
G	Centre Exhaust outlet		265	265	310	265	265	310
H	Height of Unit		850	850	850	850	850	850
	Flue connection		60	100	60	100	100	100

* Connection for Mital plus, Mital max, Montreux plus & Montreux max when used with a twin flue system.

5.0 Ventilation

Mital & Montreux



Combustion ventilation - a permanent air vent is required directly to outside, or to an adjacent room ventilated to outside, with a minimum of 100 cm² of free air space. If air ventilation is to be via another room, the room cannot be a bathroom, bedroom, garage or a room that contains either a shower or a bath.

Compartment Ventilation - if the boiler is to be installed in either a cupboard or compartment, permanent air vents are required at high and low levels see table below for sizes. Where the compartment air vents communicate with a room, the room must itself be ventilated with a minimum of 100 cm².

The air vents must both communicate with the same wall/room, and if communicated into a room, the room must not be a bathroom, bedroom, garage or a room that contains either a shower or a bath.

Boiler Type	Combustion Ventilation	Compartment Ventilation		
		Position of vents	Air from Room	Air from Outside
Mital & Montreux	100 cm ²	High	201 cm ²	100 cm ²
		Low	402 cm ²	201 cm ²
Mital plus & Montreux plus	None Required	High	201 cm ²	100 cm ²
		Low	201 cm ²	100 cm ²
Mital max & Montreux max	None Required	High	285 cm ²	142 cm ²
		Low	285 cm ²	142 cm ²

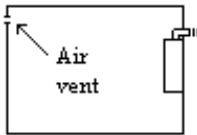
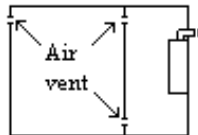
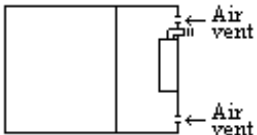
Figure. 2 - Air Vent Positions.

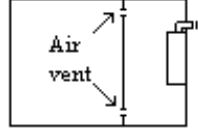
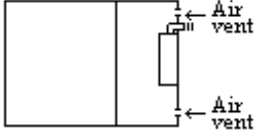
Boiler type	Boiler location	In a Room	In a compartment Vented to a Room	In a compartment Vented to Outside
Mital Montreux				
Mital plus Mital max Montreux plus Montreux max				

6.0 Flueing

General Position

- Siting should not cause an obstruction or the discharge a nuisance. It should be remembered that in certain weather conditions a terminal may steam.
- If the terminal is below 2 metres from floor level or where people have access a terminal guard must be fitted. The guard must be symmetrically positioned ensuring a minimum of 50mm gap between the end of the terminal and the guard.
- If the terminal is within 600mm below plastic guttering, then an aluminium shield of 1.25 metres long should be fitted to the under side of the guttering.
- The terminal or flue must not be closer than 25mm to any combustible material.

Figure. 3 - Flue Terminal Position

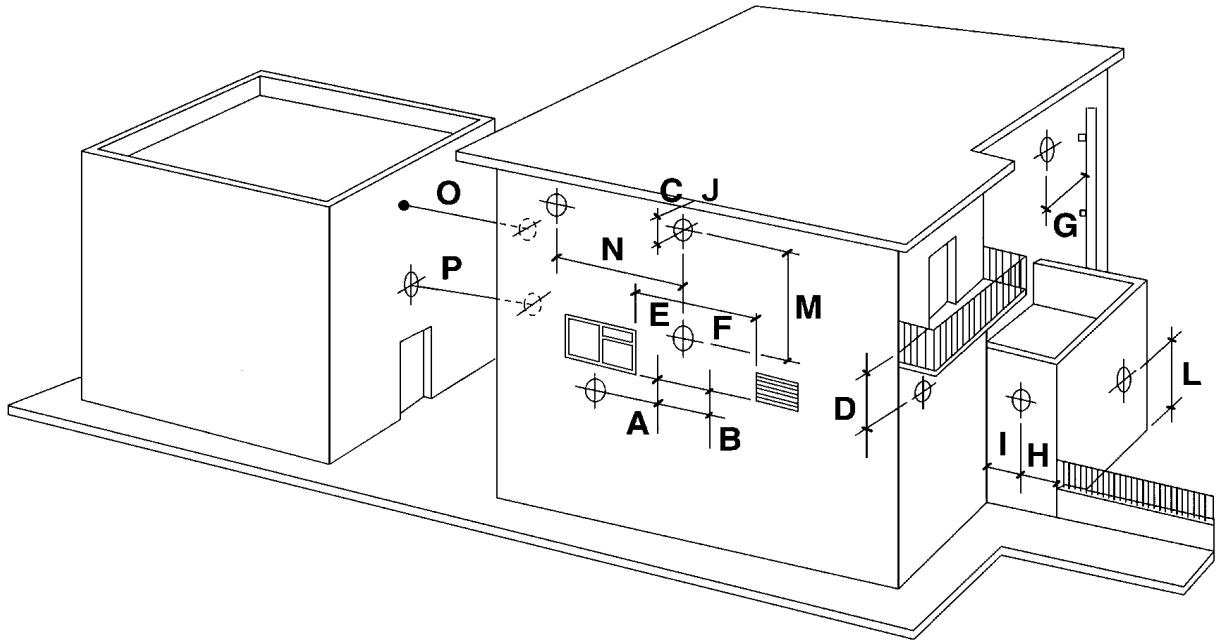

Dimension	Minimum Distances from the Flue Terminal	(mm)
A	Directly below an opening window	300
B	Directly below an air vent	300
C	Below gutters, soil pipes or drain pipes	75
D	Below a Balcony	200
E	Horizontal from a window or door on the same wall	300
F	Horizontal from an air vent on the same wall	300
G	From vertical drain pipes and soil pipes	75
H	From external corners	300
I	From internal corners	300
J	Below eaves	200
L	Above ground, roof or balcony level	300
M	Vertical from a terminal on the same wall	1500
N	Horizontal from a terminal on the same wall	300
O	From a surface facing a terminal	600
P	From a terminal facing a terminal	1200

7.0 Boiler Siting

The boiler is mounted by means of the two anchoring hooks supplied.

Measure and mark the two boiler fixing points on the wall and the pipe manifold position, making sure that the distance from boiler fixings to manifold fixings is 688mm. Ensure that the minimum clearances around the boiler are achieved as per Figure 1, and that the top of the boiler is a minimum of 2.2 metres from the finished floor level (F.F.L.) or suitable provision made to restrict accidental access to the top of the boiler.

Figure. 4 - Boiler & Manifold Fixing Points

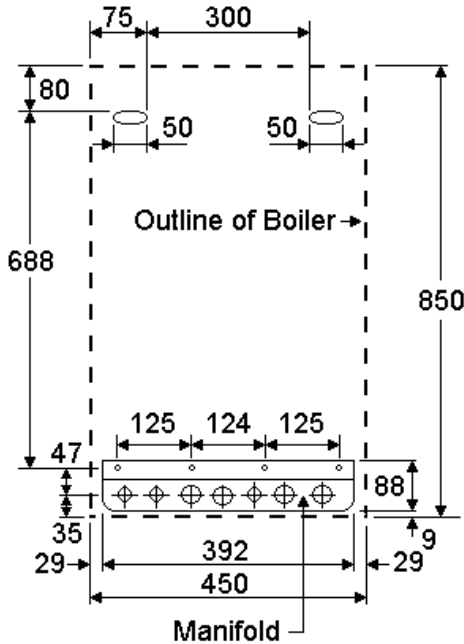

The connection manifold is provided complete with valves and angled connecting pipes, this provides two functions :

- It provides the bottom fixing for the boiler and must be adequately secured to the wall.
- The manifold enables the system to be completely pre-piped and tested with the boiler being the final fix. Thus minimising security risks.

WARNING :- Remove the straight connector from the pipe connections on the boiler, making sure any blanking pieces are disposed of.

The manifold kit is assembled by first feeding the threaded end of the 90° angled pipe through the manifold mounting plate, and then screwing the isolating valve to the angled pipe with suitable jointing (for the sanitary connection on the Mital and Mital plus boilers a straight connector is provided).

The boiler pipe can then be connected to the isolation valve and the straight connector made on to the bottom of 90° bend using the fibre washers provided.

Figure. 5 - Manifold Assembly

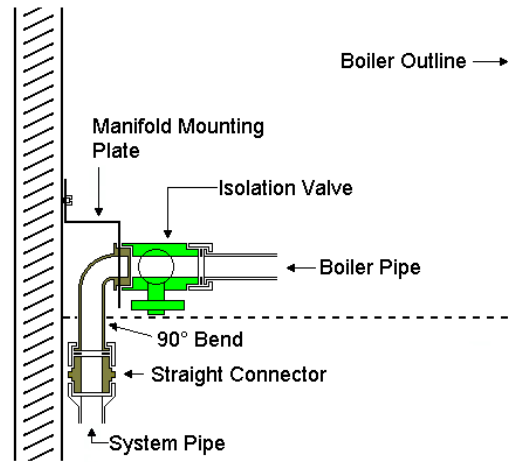

8.0 Flue Assembly

Mital & Montreux - The standard flue assembly kit contains 1 x 90° Bend, 1 Metre 60mm Ø flue pipe and 60mm Ø terminal. Additional 1 metre flue extensions and bends can be supplied at extra cost.

Maximum flue length with one 90° bend is 6 metres, additional 90° bends are equivalent to 1 metre and must be deducted from the maximum length allowed.

Mital plus, Mital max, Montreux plus & Montreux max - The standard balanced flue assembly kit contains 1 x 90° coaxial bend, 1 Metre 100mm Ø coaxial flue pipe and 100mm Ø terminal. Additional 1 metre coaxial flue extensions and bends can be supplied at extra cost.

With the Mital plus, Mital max, Montreux plus and Montreux max boilers it is also possible to have a twin pipe flue system so intake air and exhaust gas can be in different positions.

Supplied with the boiler is a bag containing the relevant flue adapters for use with a coaxial flue or a twin pipe flue system.

Figure. 6 - Flue Adapters

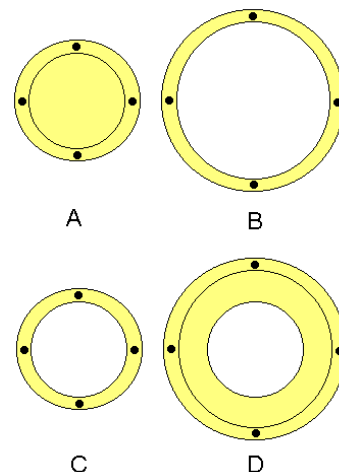

For a coaxial flue system adapters **A & B** need to be fitted as per Figure. 7.

Figure. 7 - Coaxial Flue System.

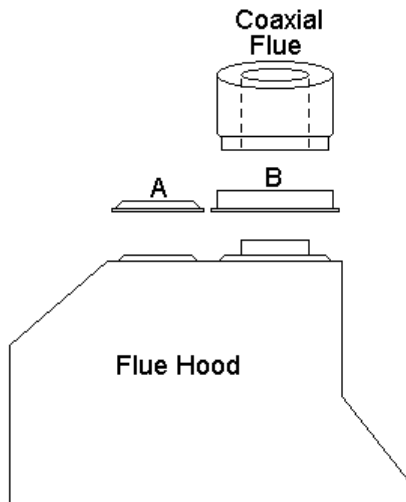

For a twin pipe flue system adapters **C & D** need to be fitted as per Figure. 8.

Figure. 8 - Twin Pipe Flue System.

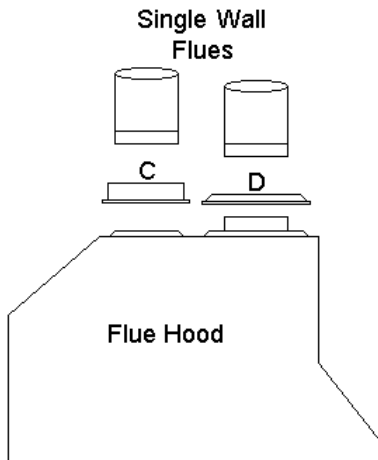

The Mital plus and Montreux plus are supplied with a flue gate that is positioned on the front of the flue hood. It has two positions (-) & (+) (Figure 9) which is dictated by maximum flue length.

With the flue gate in position (-) for a coaxial flue system with one 90° bend and the standard terminal fitted, the maximum equivalent flue pipe length is 1.5 metres. For a twin pipe system the maximum equivalent flue pipe for the intake and exhaust with a 90° bend and the standard terminal is 1.5 meters for each.

For greater flue runs the gate should be moved to position (+) which then increases the maximum equivalent flue length for the coaxial flue system to 3.5 metres with one 90° bend and the standard terminal fitted. For a twin pipe system the maximum equivalent flue pipe for the intake and exhaust with a 90° bend and the standard terminal is increased to 3.5 meters for each.

For the Mital max & Montreux max the maximum equivalent flue length for coaxial flue is 3.5 metres with one 90° bend and the standard terminal fitted. For a twin pipe system the maximum equivalent flue pipe for the intake and exhaust with a 90° bend and the standard terminal is 3.5 meters for each.

In all cases additional 90° bends are equivalent to 1 metre and must be deducted from the maximum flue length allowed.

Figure. 9 - Boiler Flue Gate.

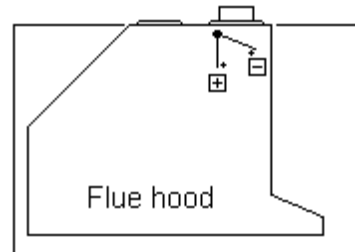

NOTE : The flues must be installed with a 3° drop from the boiler to ensure any condense or rain water drains towards the terminal thus preventing damage to the boiler.

The Mital and Montreux flue can be installed into a chimney providing it is of suitable size and construction and in a accordance with current regulations. For installing the Mital plus, Mital Max, Montreux plus and Montreux max boilers into a chimney the twin flue pipe system must be used.

When cutting coaxial flue it is essential to ensure the inner exhaust pipe is sufficiently longer than the outer ventilation pipe to ensure a good seal is achieved.

9.0 Flue and Boiler Accessories

Mital & Montreux	
60mm Ø Flue Kit (60° bend, 1m flue, terminal, seals)	
90° 60mm Ø bend	
1m 60mm Ø flue extension	
45° 60mm Ø bend	

Mital plus, Montreux plus, Montreux max	
Coaxial Flue Kit (90° bend, 1m flue, terminal, seals)	
90° coaxial bend	
1m coaxial flue extension	
45° coaxial bend	

General	
Programmer Automatic bypass valve	Increased pump
Increased expansion vessel 8 dm ³	Increased expansion vessel 12 dm ³

10. Gas Supply

The gas meter and gas supply must be capable of supplying the quantity of gas for the boiler (see table below) in addition to the demand from other gas-fired appliances.

The meter and gas supply must be sized to ensure a nominal pressure of 20 mbar is available at the appliance. The gas supply should be checked to ensure that the gas line is sound and that it has been installed in accordance with current regulations relating to gas installations.

Boiler Type	Boiler Gas Consumption m ³ /hr
Mital, Mital plus, Montreux & Montreux plus	2.8
Mital max & Montreux max	3.69

10.1 LPG Conversion

Conversion kit :

LPG Kit	Part Used on:
0.75mm GPL Injectors	all
copper washers	all
2 x "GPL" Stickers	all
1 x 0.22 Pilot Injector	Mital & Montreux
1 x Silicon Gasket	plus & max models
5 x Fibre washers	plus & max models

1. Isolate the boiler from the mains electricity supply.
2. Loosen the two screws on the control panel and pull the panel forward.
3. Remove pilot and exchange injector (Mital & Montreux)
4. Remove the ignition & detection electrodes (Mital plus, Mital max, Montreux plus & Montreux max)
5. Remove the burner (see maintenance section & figure 23)
6. Replace the burner injectors
7. Replace sticker on gas valve and inside of control panel to show new fuel
8. Re-assemble boiler
9. Test all connections disturbed for leaks
10. Adjust high & low gas pressures as per commissioning instructions and figure 20,21 & 22.
11. Re-seal test points and check for leaks.

12.0 Sealed Primary System

All the Mital & Montreux range of boilers must be fitted with a bypass if thermostatic radiator valves are used, alternatively one radiator can be used as a

11.0 Cold Water Supply (Mital, Mital plus & Mital max only)

A minimum pressure of 0.4 bar is required at the appliance to enable the boiler to function. However a greater pressure is required if the stipulated flow rate is to be achieved.

A direct mains water connection is permitted by the Water Authorities. It is recommended that reference be made to local requirements.

Where ever possible the cold water supply to the boiler should be the first connection off the mains water supply to minimise hot water flow reduction when other water services are in use.

Within the boiler is a flow valve that must be adjusted to account for local water pressure conditions and to provide the temperature desired (see figures 10 & 11).

If the mains inlet water pressure is greater than 6 bar then a pressure reducing valve must be fitted to the mains water supply to the boiler.

Figure. - 10 CWS Flow Valve

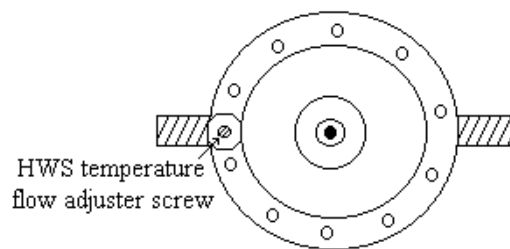
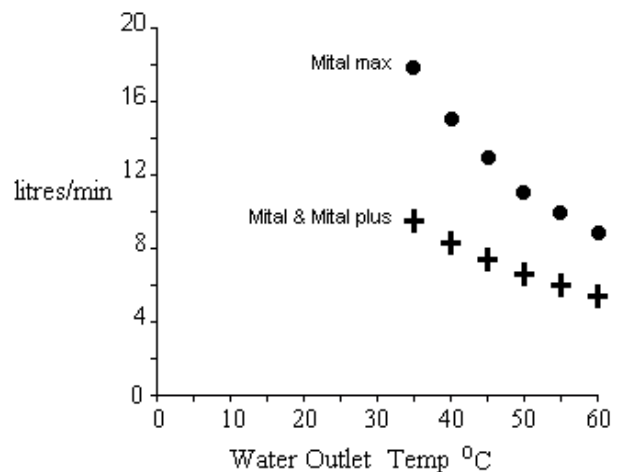

Figure. - 11 HWS Flow/Temp Graph



bypass by fitting it with standard radiator valves to enable dissipation of heat from the boilers.

Both the Mital & Montreux boiler ranges are supplied with all the necessary components. The expansion

vessel is pre-charged to 1.2 bar and guarantees operation up to a heating system capacity of 140 litres operating at a maximum of 85°C (220 litres Mital max & Montreux max) and with a static head of up to 12 metres.

Filling of the system must be via a temporary hose connection to the mains water supply, with a double check valve assembly and test point on the system side of the temporary connection. As per Water Regulation Bye-law 14.

All valves and joints should be suitable for a working pressure of 3 bar. Radiator valves should comply with BS 2767:10. All other valves and fittings should comply with BS1010.

The discharge from the Safety Valve MUST be run to a safe position outside of the building. REMEMBER the discharge from the safety valve will be HOT and must be discharged at low level.

All boilers have an integral three speed pump built into the boiler. In most cases Speed - III is suitable. If a greater pump is required this can be achieved by replacing the standard pump with the larger pump (see accessories).

Figure 12a - Mital, Mital plus boiler Resistance & Pump diagram.

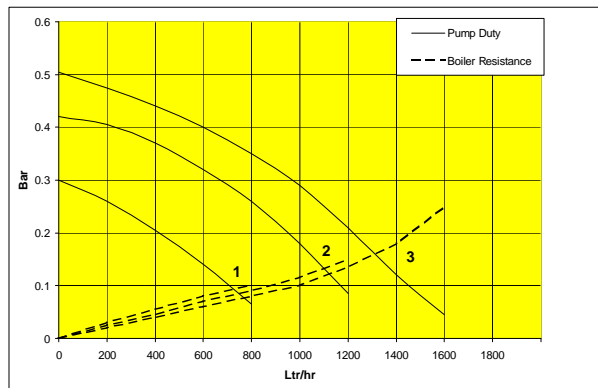

Figure 12b - Mital max boiler Resistance & Pump diagram.

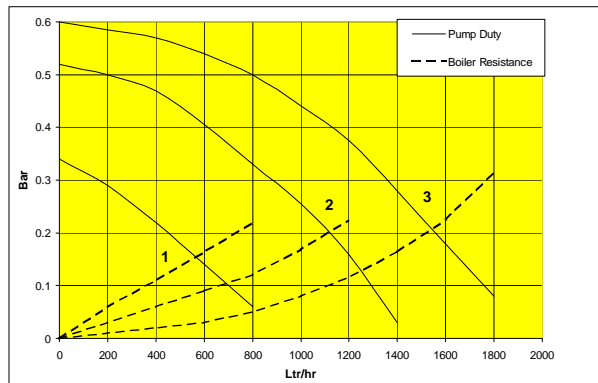

Figure 12c - Montreux, Montreux plus boiler Resistance & Pump diagram.

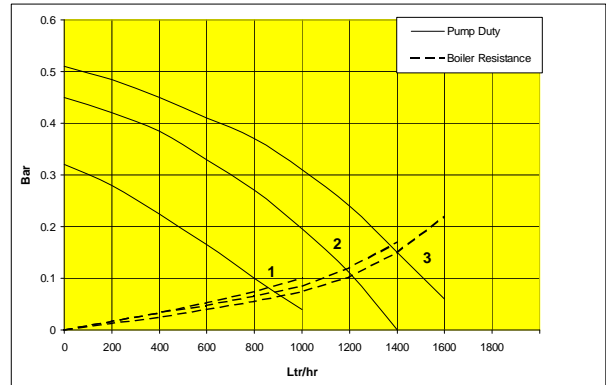
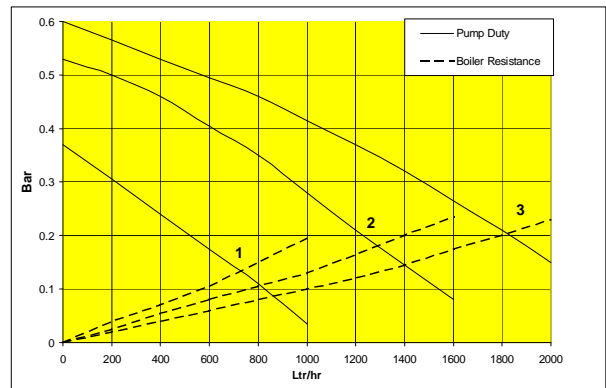

Figure 12d - Montreux max boiler Resistance & Pump diagram.



13.0 Electrical System

External wiring MUST be in accordance with current I.E.E. Regulations and all other Local Regulations.

The boiler is supplied for 230 VAC, 50Hz, Single Phase.

The method of connection to the electricity supply must facilitate complete isolation of the boiler. This can be achieved either by use of a fused three-pin plug and shuttered socket outlet, both complying with BS1363, or by use of a fused-double pole switch with a contact separation in both poles of at least 3mm.

Which ever method is used the point of disconnection of the electricity supply must be adjacent to the boiler, with the exception of boilers that are fitted in either a bathroom or shower room. In these cases the point of disconnection MUST be outside the bathroom and it is advised that the method of disconnection should include removal of fuse to avoid accidental re-connection.

ATTENTION: Ensure that the phase and neutral electrical polarities are correct and the earth connection is made. Any mistakes could permanently lock out the burner.

Earth continuity and electrical tests must be carried out prior to initial operation of the boiler. The manufacturer and the supplier are **NOT** responsible for any damage to persons or property resulting from lack of compliance with this requirement.

13.1 Internal wiring

Diagrams of the internal wiring are provided in figures 13, 14, 15, 16 & 17 on the following page.

13.2 External Controls

For external controls reference should be made to both the relevant control manufacturers Instructions and the boiler wiring diagrams shown in figures (13, 14, 15, 16 & 17).

If the integral programmer is to be utilised the following sequence should be followed:

- Pull forward the front control panel cover.
- Loosen the left and right screws and remove the control panel back cover.
- Breakout the cover disk on the panel.
- Mount the programmer by means of the four screws provided.
- Make electrical connection using the cable connector marked "programming timer".

Figure 13 Mital Internal Wiring Diagram

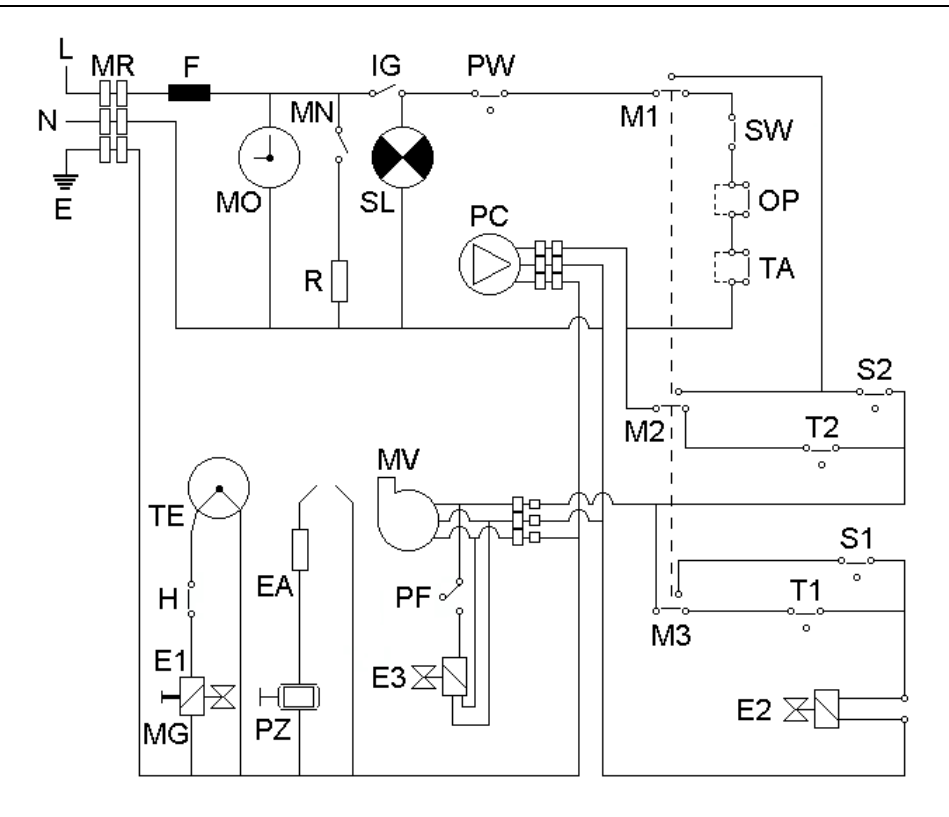
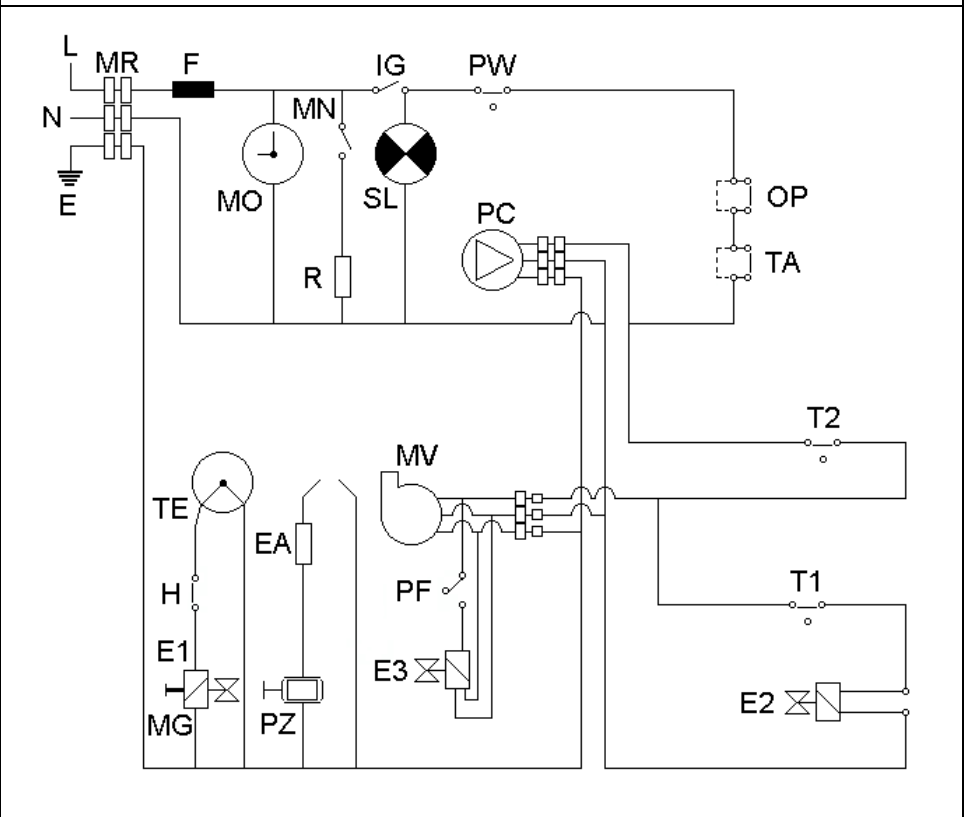

Figure 14 Montreux Internal Wiring Diagram



E2 Gas Solenoid Modulation
 E3 Main Gas Solenoid
 EA Ignition Electrode
 F Fuse
 H High Limit Thermostat
 H2 N/A
 IG Boiler On / Off Switch
 M1, 2 & 3 Hot Water Priority Switch

MN N/A
 MO Permanent Live for Time Clock
 MR Terminal Strip
 MV Fan Motor
 OP Heating Timer Connections
 PC Pump
 PF Air Pressure Switch
 PW Water Pressure Switch

R N/A
 S1 Hot Water Control Thermostat Stage 2
 S2 Hot Water Control Thermostat Stage 1
 SL Power On indication
 SW Summer / Winter Switch
 T1 Boiler Control Thermostat Stage 2
 T2 Boiler Control Thermostat Stage 1
 TA Room Thermostat (Optional)

Figure 15 Mital Plus Internal Wiring Diagram

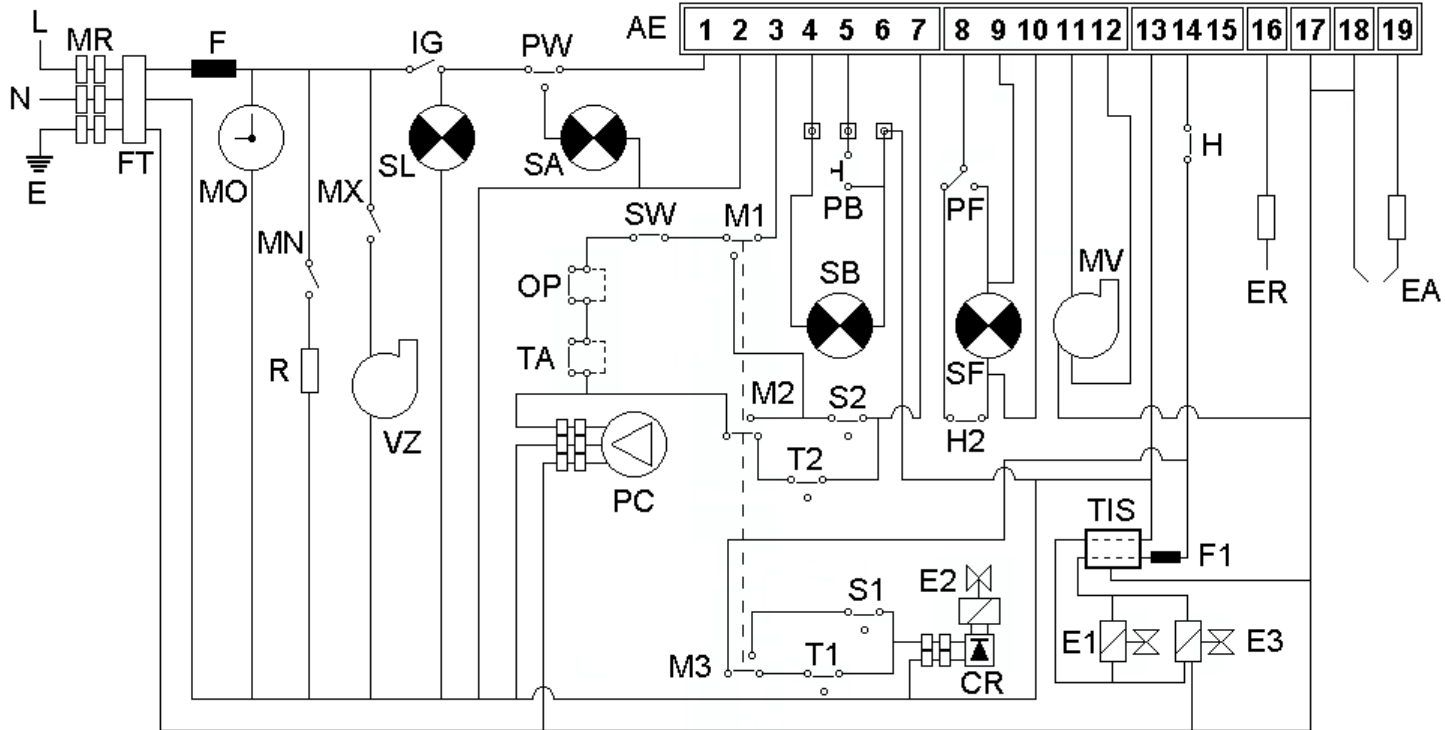

AE	Control Box	M1, 2 & 3	Hot Water Priority Switch	S2	Hot Water Control Thermostat Stage 1
CR	Rectifier (SIT Only)	MN	N/A	SA	Low Water Pressure Warning Light
E1	Gas Safety Solenoid	MO	Permanent Live for Time Clock	SB	Lock-Out Warning Light
E2	Gas Solenoid Modulation	MR	Terminal Strip	SF	Flue Warning Light
E3	Main Gas Solenoid	MV	Fan Motor	SL	Power On indication
EA	Ignition Electrode	MX	N/A	SW	Summer / Winter Switch
ER	Flame Detection Probe	OP	Heating Timer Connections	T1	Boiler Control Thermostat Stage 2
F	Fuse	PB	Lock-Out Reset Button	T2	Boiler Control Thermostat Stage 1
F1	Fuse	PC	Pump	TA	Room Thermostat (Optional)
FT	Electrical Filter	PF	Air Pressure Switch	TIS	Transformer
H	High Limit Thermostat	PW	Water Pressure Switch	VZ	N/A
H2	N/A	R	N/A		
IG	Boiler On / Off Switch	S1	Hot Water Control Thermostat Stage 2		

Figure 16 Montreux Plus & Max Internal Wiring Diagram

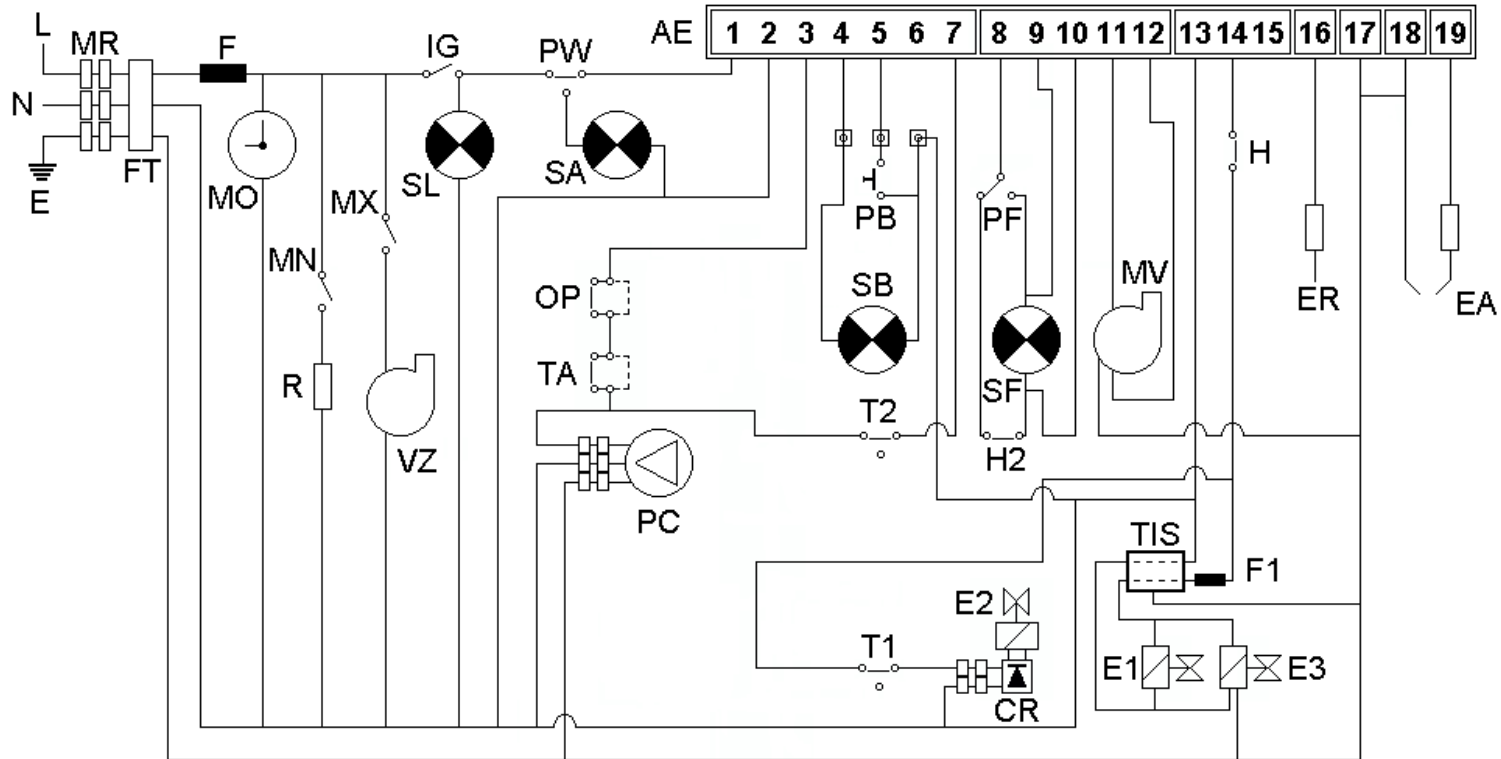

AE	Control Box	IG	Boiler On / Off Switch	SA	Low Water Pressure Warning Light
CR	Rectifier (SIT Only)	MN	N/A	SB	Lock-Out Warning Light
E1	Gas Safety Solenoid	MO	Permanent Live for Time Clock	SF	Flue Warning Light
E2	Gas Solenoid Modulation	MR	Terminal Strip	SL	Power On indication
E3	Main Gas Solenoid	MV	Fan Motor	SW	Summer / Winter Switch
EA	Ignition Electrode	MX	N/A	T1	Boiler Control Thermostat Stage 2
ER	Flame Detection Probe	OP	Heating Timer Connections	T2	Boiler Control Thermostat Stage 1
F	Fuse	PB	Lock-Out Reset Button	TA	Room Thermostat (Optional)
F1	Fuse	PC	Pump	TIS	Transformer
FT	Electrical Filter	PF	Air Pressure Switch	VZ	N/A
H	High Limit Thermostat	PW	Water Pressure Switch		
H2	N/A	R	N/A		

Figure 17 Mital Max Internal Wiring Diagram

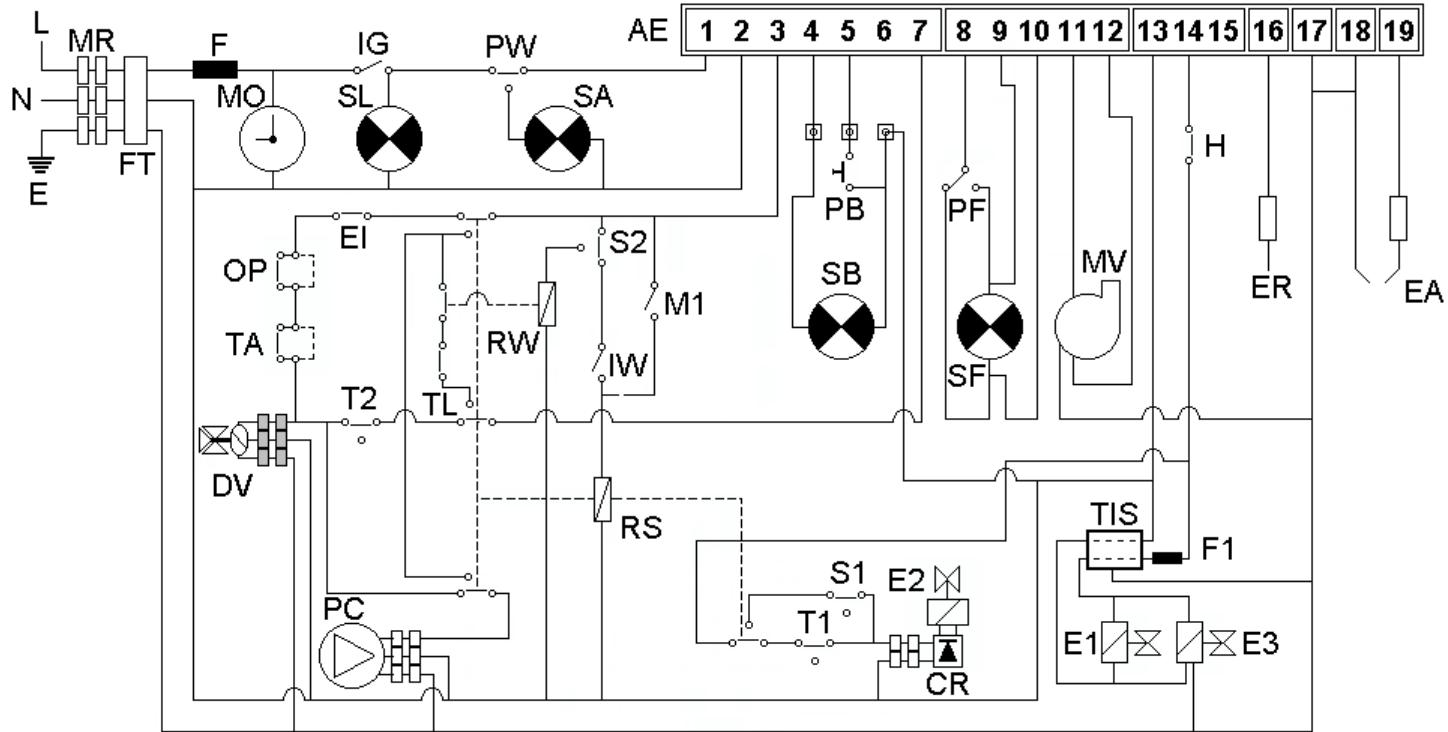

AE	Control Box	IW	Hot Water Switch	S1	Hot Water Control Thermostat Stage 2
CR	Rectifier (SIT Only)	M1, 2 & 3	Hot Water Priority Switch	S2	Hot Water Control Thermostat Stage 1
DV	Diverting Valve	MO	Permanent Live for Time Clock	SA	Low Water Pressure Warning Light
E1	Gas Safety Solenoid	MR	Terminal Strip	SB	Lock-Out Warning Light
E2	Gas Solenoid Modulation	MV	Fan Motor	SF	Flue Warning Light
E3	Main Gas Solenoid	OP	Heating Timer Connections	SL	Power On indication
EA	Ignition Electrode	PB	Lock-Out Reset Button	SW	Summer / Winter Switch
ER	Flame Detection Probe	PC	Pump	T1	Boiler Control Thermostat Stage 2
F	Fuse	PF	Air Pressure Switch	T2	Boiler Control Thermostat Stage 1
F1	Fuse	PW	Water Pressure Switch	TA	Room Thermostat (Optional)
FT	Electrical Filter	RS	4 Contact Relay	TIS	Transformer
H	High Limit Thermostat	RW	1 Contact Relay	TL	Hot Water Limit Thermostat
IG	Boiler On / Off Switch				

14.0 Commissioning

The heating system including the radiators and domestic hot water circuit must be thoroughly flushed. The system should be completely filled and 'cold flushed' without the boiler in-situ. The boiler should then be connected, electrical and gas safety tests/checks completed and passed. The system should then be refilled, brought to temperature and a 'hot flush' carried out.

The system can then be refilled and all air locks removed and the system checked for water leaks.

Dependant upon location it may be necessary for the system water and the mains feed water (Mital, Mital plus & Mital max ONLY) to be treated to protect the boiler from scale and sludge formation. The Local Water Authorities should be consulted. If required the following products are recommended:

System water treatment - Fernox MB-1 if steel radiators are used & Fernox Copal when aluminium is present in the system i.e. radiators.

Mains water treatment - Fernox Quantomat (Mital, Mital plus & Mital max only).

Operation of the boiler and controls should be checked.

Check gas valve is correct for fuel supply (GPL = LPG & Methano = Methane), then check the burner pressure.

	Inlet pressure mbar	Outlet pressure High Fire mbar	Outlet pressure Low Fire mbar
Natural Gas	20	10	2.5
L.P.G.	37	35	10

If the gas pressure at the burner (injector) does not correspond to the values shown above, commission the unit as follows :-

Mital & Montreux.

To check the pressure at the burner, connect a pressure gauge to the burner pressure test point **11** (Figure-18) after having slackened the internal screw by a few turns and remove yellow plastic cap **5**.

Figure. 18 - Honeywell V4600 Gas Valve.

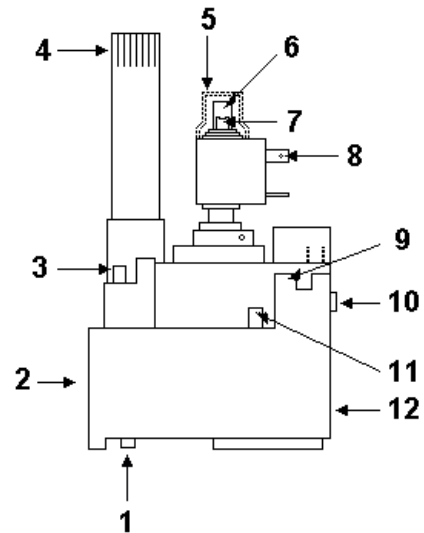

KEY

1	Thermocouple connection.
2	Gas valve inlet.
3	Gas inlet pressure test point.
4	Gas valve control knob.
5	Adjustment screw cover.
6	High gas pressure adjustment nut.
7	Low gas pressure adjustment screw.
8	Modulating solenoid electrical connections.
9	Pilot burner adjustment screw.
10	Pilot burner connection.
11	Burner pressure test point.
12	Gas valve outlet.

- To adjust the High fire pressure turn the boiler on (as per section 16.0 Users Instructions) and with it operating on high fire adjust nut **6** with a 8mm spanner to the correct pressure (turning the nut clockwise increases the burner pressure).
- To adjust the Low fire pressure, turn the boiler off at the mains and disconnect the electrical connections **8** from the modulating solenoid (**WARNING** - these connections will become live when the boiler is switched on, cover the ends with electrical tape while low fire pressure is adjusted). Switch the boiler on and adjust screw **7** to the correct pressure while keeping nut **6** locked off with the spanner (turning the screw clockwise increases the burner pressure).
- Turn off the boiler and re-connect electrical connections for the modulating solenoid and check the High and Low fire pressure values, readjust if required and then re-fit Yellow plastic cap **5**.
- Check that the pilot flame length is correct i.e. covering the thermocouple bulb, if adjustment is required turning the screw **9** clockwise decreases the burner pressure.

Mital plus, Mital max, Montreux plus & Montreux max.

To check the pressure at the burner, connect a pressure gauge to the burner pressure test point **3** (Figure - 19) after having removed the screw and remove clear plastic cap **C** (Figure. 20).

Figure. 19 - SIT 836 Nova Gas Valve.

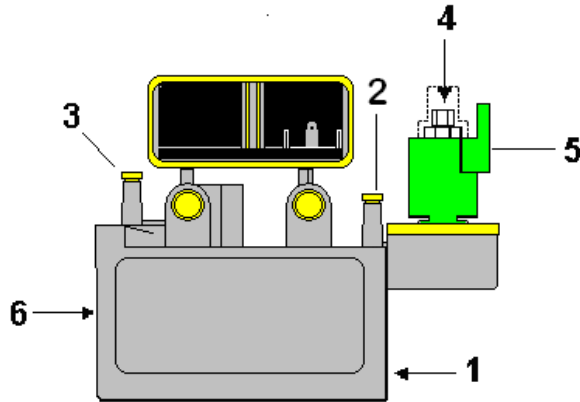

KEY

1	Gas valve inlet.
2	(E) Gas inlet pressure test point.
3	(A) Burner pressure test point.
4	High and Low gas pressure adjustment (as per Figure - 20).
5	Modulating solenoid electrical plug
6	Gas valve outlet.

- To adjust the High fire pressure turn the boiler on and with it operating on high fire adjust nut **B** (Figure - 20) with a 10mm spanner to the correct pressure (turning the nut clockwise increases the burner pressure).
- To adjust the Low fire pressure, turn the boiler off at the mains and disconnect the electrical plug **5** (Figure - 19) from the modulating solenoid (**WARNING** - the plug will become live when the boiler is switched on, take care not to poke inside the plug). Switch the boiler on and adjust screw **A** to the correct pressure while keeping nut **B** locked off with the spanner (turning the screw clockwise increases the burner pressure).
- Turn off the boiler and re-connect electrical plug for the modulating solenoid and check the High and Low fire pressure values, readjust if required and then re-fit clear plastic cap **C**.

Figure. - 20 SIT 836 Nova Gas Valve, High and Low Gas Pressure Adjustment.

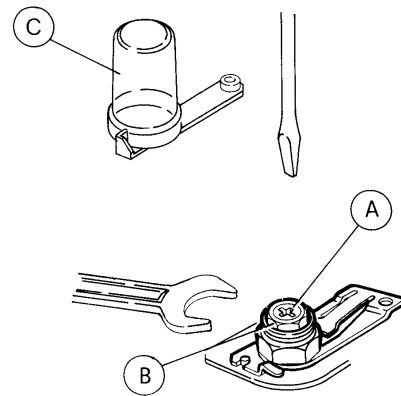

Mital, Mital plus & Mital max - the hot water flow rate **MUST** be adjusted. The integral flow regulator (see figure 10) is not a pressure reducer; therefore, high pressure above 6 bar on the Mains water system has to be reduced by means of an external pressure reducer.

Check the position of the flue gate (see figure 9) is correct for flue length etc. Ensure flue operation is correct and clean, and that any condense or rain water in the flue pipes are collected and drained without reaching the equipment.

Ensure the cap on the automatic air release valve is loose and the valve is functioning correctly.

IMPORTANT

After the unit has been commissioned, check :-

1. The electrical connections of the gas valve.
2. All gas lines should be re-checked for soundness using leak detector solution.
3. All pressure test points are checked for soundness.
4. The correct operation of all the control and safety devices.

14.1 Handing Over

After completing the installation the installer should demonstrate the operation of the boiler and any system controls to the user.

ALL instruction **MUST** be handed to the user for retention and advice given regarding the need for annual servicing.

15.0 Maintenance

1. Removal of Burner

- Isolate both the electrical and gas supply to the boiler.
- Open the boiler control cover.
- Remove the two self tapping screws at bottom of front case.
- Pull the front case forward, at the bottom and lift.
- Remove the ten self tapping screws from the outer combustion chamber cover.
- Remove the self tapping screws from the inner combustion chamber cover (Mital plus, Mital max, Montreux plus and Montreux max) and remove.
- Disconnect and remove ignition probe and either pilot burner or flame detection probe.
- Remove the four burner fixing screws and pull assembly forward as per Figure. 21.
- Check the injectors for damage or blockage.
- Inspect the burner gas ways for damage or blockage. Vacuum or blow out any lint or dirt.
- Check the burner plaques for signs of cracking, distortion or leaking. Replace if damaged.
- Gently brush the top of the burner with a soft brush and blow away any deposits.
- Inspect the combustion chamber insulation for signs of charring or damage. Replace if required.
- Check the fan assembly for signs of wearing, over heating or distortion.
- Remove fan assembly and inspect for damage. Remove any dust and replace.

Figure. - 21 Burner Fixing Screws.

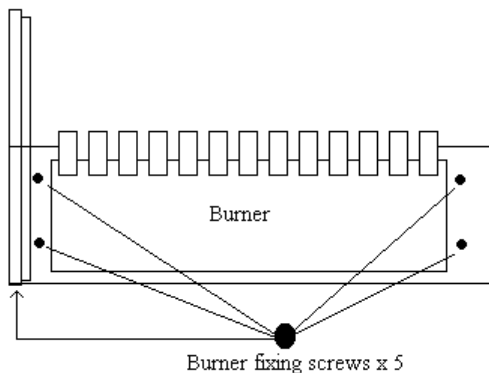

2. Pilot Burner (Mital and Montreux)

- Check the injectors for damage or blockage.
- Inspect the burner gas ways for damage or blockage.
- Vacuum or blow out any lint or dirt.

3. Clean Flueways

- Cover the controls and burner injectors with a waterproof sheet.

- Remove flue hood by removing the three fixing screws and disconnecting the electrical wires for the fan.
- Remove all loose deposits from the heat exchanger, particularly between the fins, working from above and below the heat exchanger, using a suitable brush.

- Once clean reassemble burner, fan, and pilot.

4. After Service Checks

- Check the distance between burner or pilot head and the ignition and detection electrodes are 3mm.
- Check pilot burner or flame detection probe are correctly aligned.
- Complete re-assembly of boiler and case.
- Turn ON both the gas and electrical supply.
- Check boiler 'LIVE' light is illuminated.
- Set controls to 'calling'.
- Observe lighting sequence, ensuring quiet burner ignition.
- Check burner & pilot pressure and adjust if required.
- Observe flame picture of both pilot and burner.

15.1 Fault Finding

On the following page is a fault finding guide.

- Column 1 **Fault**, states the current fault.
- Column 2 **Warning Lights**, the Mital plus, Mital max, Montreux plus and Montreux max have a enhanced control panel to assist with fault finding. You should look down the Warning Lights column to find the sequence of lights which is displayed on the boiler with reference to the fault.
- Column 3 **Consequences**, relates to the secondary faults.
- Column 4 **Possible Causes**, of the fault in column 1.

15.2 Fault Finding Guide.

Fault	Warning Lights	Consequences	Possible Causes
Burner fails to light	○ ○ ○ ○	green light off	- No power - Main switch off - Main fuse blown - appliance fuse blown
	● ○ ● ○	water gauge around 0 bar	- low system pressure - faulty system water pressure switch
	● ○ ○ ●	fan functions	- faulty air pressure switch - blocked flue - pressure switch tubes blocked / disconnected - flue too long - boiler flue gate set in the wrong position
Boiler partially working	● ○ ○ ○	fan not working	- faulty air pressure switch - faulty fan
	● ○ ○ ○	hot water only	- room thermostat set too low - faulty room thermostat - faulty programmer / timer
Boiler partially working	● ○ ○ ○	heating only	- HWS control thermostat set too low - faulty HWS control thermostat - faulty diverter valve micro switches - faulty diverter valve
	● ○ ○ ○	burner noisy - reddish flame	- gas pressure wrong
Improper operation	● ○ ○ ○	burner noisy on ignition	- ignition source poorly aligned - faulty burner delay
	● ○ ○ ○	boiler keeps switching off and on	- radiators shut down - pump speed too low - by-pass wrongly adjusted - air lock - system too small
	● ○ ○ ○	boiler kettling	- pump speed too low - system incorrectly balanced - air in system
Radiators cold	● ○ ○ ○	boiler kettling	- pump speed too low - system incorrectly balanced - air in system
Boiler locks out	● ● ○ ○	locks out after a few seconds	- ionisation probe misalign - ionisation probe wire disconnected or broken - poor electrical earth - phase and neutral swapped - Ignition card faulty - power supply out of phase
	● ● ○ ○	boiler sparks but fails to light	- gas supply turned off - ignition probe misalign - poor gas pressure - faulty gas valve
	● ● ○ ○	locks out during normal operation	- faulty heating control thermostat - faulty hot water control thermostat - pump blocked - blocked heat exchanger - system blocked
Safety valve leaks	● ○ ○ ○	pressure gauge above 1.5 bar (cold)	- system pressure too high
	● ○ ○ ○	pressure gauge above 3 bar (hot)	- faulty expansion vessel
	● ○ ○ ○	pressure gauge normal	- faulty safety valve
HWS lukewarm	● ○ ○ ○	radiators hot when hot water is being drawn	- diverter blocked
	● ○ ○ ○	fluctuating HWS temperature	- HWS control thermostat wrongly calibrated - gas valve not calibrated - fluctuating gas pressure - faulty gas valve modulator
	● ○ ○ ○	hot primary pipe	- flow regulator misadjusted - scale build up in HWS exchanger
	● ○ ○ ○	boiler off diverter valve working	- faulty HWS control thermostat



○ = Light NOT on ● = Light ON

16.0 Users Instructions

Mital & Montreux

- 1) Press the gas knob and continually press and release the piezo electric ignition. When pilot is a light KEEP the gas knob pressed in for 20 seconds then release the knob.

If the pilot goes out try again.

- 2) Set Main switch to on (**I** = ON, **0** = OFF).
- 3) Set Summer/Winter Switch to Winter (Mital only).
- 4) Set room thermostat, programmer to calling.

To switch off the boiler set the upper switch to '0' and turn gas knob clockwise until pilot goes out and release.

Figure. 22 - Mital & Montreux Control Panel.

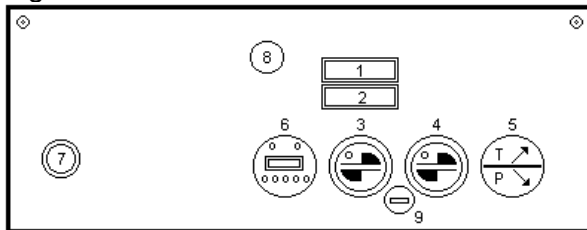

Key

- | | |
|---|---|
| 1 | On / Off Switch. |
| 2 | Summer / Winter Switch (Mital plus). |
| 3 | HWS Control thermostat (Mital plus). |
| 4 | Central Heating Control thermostat. |
| 5 | Top half Central Heating temperature gauge
Bottom half Central Heating pressure gauge. |
| 6 | Optional Programmer. |
| 7 | Gas valve Control Knob |
| 8 | Piezo ignition button. |
| 9 | Fuse holder. |

Mital plus, Mital max, Montreux plus and Montreux max

- 1) Main switch **I** = ON, **0** = OFF.
- 2) Winter Summer / Winter Switch (Mital only).
- 3) Set room thermostat, programmer to calling.

 Power ON light.

-  When lit the boiler has locked out: after 20 seconds, press red reset button, if boiler locks out again professional advice should be sought.

 When lit the system has low pressure: system needs to be recharged to 1 bar when cold and system checked for leaks.

 If this remains lit after 10 minutes a problem exists on the flue. Switch OFF the boiler and contact a qualified gas service engineer.

Figure. 23 - Mital plus, Mital max, Montreux plus & Montreux Max Control Panel.



Key

- | | |
|----|---|
| 1 | On / Off Switch. |
| 2 | Summer / Winter Switch (Mital plus). |
| 3 | HWS Control thermostat (Mital plus). |
| 4 | Central Heating Control thermostat. |
| 5 | Top half Central Heating temperature gauge
Bottom half Central Heating pressure gauge. |
| 6 | Optional Programmer. |
| 7 | Mains power indicator. |
| 8 | Boiler lock out warning light. |
| 9 | Low system pressure warning light. |
| 10 | Flue problem warning light. |
| 11 | Control box lock out light and re-set button. |
| 12 | Fuse holder. |
| 13 | Hot water holding switch |

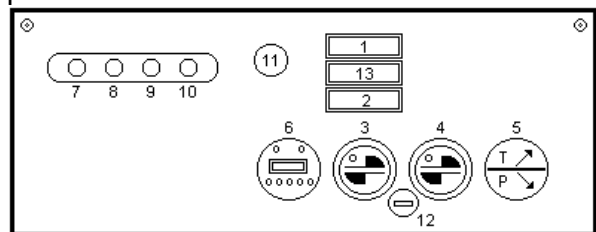
SERVICE HOTLINE

STREBEL provide a 'Service Hotline' to installers and end users to ensure customers get the best from their product. STREBEL also manage a network of approved service agents that can provide an annual service or breakdown repairs. So if you require technical advice, an annual service or repair call STREBEL on: 01276 - 679144 or 685422.

Parts Check List

3 x Cartons -
1xBoiler carton
1xFlue carton
1xManifold and valve carton

Boiler carton contains:

1x Boiler
4x Flue adapters
8x Self tapping screws
4x Straight connectors

Flue carton contains:

1x 90° Flue Bend
1x Metre flue pipe
1x terminal.
1x Flue Washer set
1x Inner rubber wall seal

Additional 1 metre flue extensions and bends can be supplied separately at extra cost.

Manifold and valve carton contains:

1x Connection manifold
5x Angled pipe connectors
4x Isolation valve

The company reserves the right to change the specification and dimensions without prior notice

E. & O.E.

STREBEL Ltd.

1F, Albany Park Industrial Estate
Frimley Road, Camberley
Surrey GU16 2PB
Telephone : (01276) 685422
Fax: : (01276) 685405

04/01.