

# Installation & Servicing Instructions

## S-HQ boiler range



# STREBEL

These instructions to be retained by user.

## Explanations of symbols and signs on the Control Tower display.

### Operation indication

(in the first display position by technical read out)

0	No heat requirement
1	Ventilation phase
2	Ignition phase
3	Burner active on central heating
4	Burner active on hot water
5	Fan check
6	Burner off when room thermostat is demanding
7	Pump overrun phase for central heating
8	Pump overrun phase for hot water
9	Burner off because of too high flow water temperature
R	Automatic venting programme

display

Central heating *on / off*



+

step

Step key

*Selecting chapters*

Domestic hot water (DHW) *on / off*



-

Reset key

*Unlocking the boiler in case of error*

Pump programme *on / off*



store

Mode key *Selecting chapters*

mode

reset



**From Good-read out to Technical read out (and vice versa):**  
- Press 5 sec. on the STEP key.

**FILL**

Water pressure is too low (<0,7 bar), FILL indication remains continuously visible, the boiler is taken out of operation. The installation needs to be topped up.



Water pressure is too low (<1,0 bar), flashing FILL will alternate with indication of water pressure, boiler power of 50% is possible. The installation needs to be topped up.

**HIGH**

Water pressure is too high (>2,8 bar), if HIGH indication remains continuously visible, the boiler is taken out of operation. The installation pressure needs to be decreased by draining water.

# Content

1	Introduction .....	4
2	Rules .....	4
3	Scope of the supply .....	6
4	Description of the boiler .....	6
5	Mounting the boiler .....	8
6	Connecting the boiler .....	9
	6.1 Central heating system .....	9
	6.2 Expansion vessel .....	11
	6.3 Expansion vessel module .....	12
	6.4 Underfloor heating system (plastic pipes) .....	13
	6.5 Water quality .....	13
	6.6 Gas connection .....	15
	6.7 Hot water supply .....	15
	6.8 Condensation drain pipe .....	16
	6.9 Flue gas exhaust system and air supply system .....	18
	6.9.1 Dimensions of the flue gas and air intake duct .....	22
7	External hot water cylinders .....	23
8	Electrical connection .....	24
9	Boiler controls .....	26
	9.1 Explanation of the function keys .....	27
10	Filling and venting the boiler and installation .....	28
	10.1 Hot water supply .....	28
11	Commissioning the boiler .....	29
	11.1 Central heating system .....	29
	11.2 Hot water supply .....	29
	11.3 Adjustments .....	30
	11.4 Activating factory settings (green key function) .....	32
12	Isolating the boiler .....	33
13	Commissioning .....	33
	13.1 Checking for contamination .....	34
	13.2 Checking the O <sub>2</sub> .....	35
	13.3 Maintenance activities .....	36
	13.4 Draining the installation .....	38
	13.5 User's instructions .....	39
	13.6 Maintenance frequency .....	39
	13.7 Warranty .....	39
14	Error indication .....	40
Annex A	Technical specifications .....	40
Annex B	Additives .....	42
Annex C	Dimensions .....	43
Annex D	Installation examples .....	45
	D.1 Radiator installation without thermostatic radiator valves .....	45
	D.2 Radiator installation with underfloor heating zone .....	46
Annex E	Declaration of Conformity .....	47
Annex F	Kiwa certificate .....	48
	Benchmark Checklist .....	49
	Service Record .....	50
	Benchmark Checklist .....	45
	Service Record .....	46



**Work on the installation should only be carried out by qualified personnel with calibrated equipment.**



These instructions describe the functioning, installation, use and primary maintenance of STREBEL central heating units for the United Kingdom and Ireland. Where necessary the different regulations for each country are separately described.

These instructions are intended for the use by Gas Safe Register approved contractors or registered installers in connection with the installation and putting into operation of STREBEL boilers. It is advisable to read these instructions thoroughly, well in advance of installation. Separate instructions for use are supplied with the boiler for users of STREBEL central heating boilers. STREBEL is not liable for the consequences of mistakes or shortcomings which have found their way into the installation instructions or user's manual. Further, STREBEL reserves the right to alter its products without prior notification.



**When delivering the unit, give the customer clear instructions concerning its use; present the customer with the user's manual and card.**

Each unit is fitted with an identification plate. Consult the details on this plate to verify whether the unit is compliant with its intended location, e.g.: gas type, power source and exhaust classification.

Relevant Installation, Service and User manuals:

- BrainQ Digital room thermostat
- MadQ Cascade-/Zone controller

The following regulations apply to installation of STREBEL central heating units:

Legislation and Regulations.

Gas Safety (Installation and Use). All gas appliances must by law, be installed by a competent person, eg. Members of Gas Safe Register and in accordance with the current Gas Safety Regulation. Failure to install appliance correctly could lead to prosecution.

All Gas Safe Register approved contractors carry a Gas Safe Register ID Card and have a registration number. You can call Gas Safe Register direct on 01256 372300

In addition to the above regulations this appliance must be installed in compliance with the current IEE Regulations, the Building Standards (Scotland Consolidation) Regulations. Regulations and bye laws of the Local Water Authority and the Current Health and Safety Regulation.

The current, Electricity at Work Regulation must be complied with and also be in accordance with the relevant and current editions of the British Standards.

The STREBEL S-HQ boiler is a certified appliance and must not be modified or installed in any way contrary to this Installation Manual. Manufacturers instructions must not be taken in any way as overriding statutory obligations.

The STREBEL S-HQ is a central heating unit with an optional integrated hot water function. These units must be connected according to these instructions and all installation norms in respect of the part of the unit to be connected.

Observe the following rules of safety:

- All work on the unit must take place in a dry environment.
- STREBEL units may never be in operation without their housing, except in connection with maintenance or adjustments (see Chapter 13 and 14).
- Never allow electrical or electronic components to come into contact with water.

Carry out the following tasks in connection with maintenance, etc. to an already-installed unit:

- Shut down all programmes
- Close the gas tap
- Remove the plug from the wall socket
- Close the stop cock of the unit's intake connection

Take note of the following when maintenance or adjustments are needed:

- The unit must be able to function during these activities; for this reason, the unit's supply voltage, gas pressure and water pressure must be maintained. Ensure that these is not a source of potential danger during these activities.



**Following maintenance or other activities; always check the installation of all parts through which gas flows using leak detection fluid (LDF).**



**Following maintenance or other activities, always replace the housing and secure it with the screw behind the door at the front of the casing.**

The following (safety) symbols may be encountered in these installation instructions and on the unit:



**This symbol indicates that the unit must be stored away from frost.**



**This symbol indicates that the packaging and/or contents can be damaged as a result of insufficient care taken during transport.**



**This symbol indicates that, whilst still in its packaging, the unit must be protected from weather conditions during transport and storage.**



**KEY-symbol. This symbol indicates that assembly or dismantling, must be carried out.**



**ATTENTION symbol. This symbol indicates that extra attention must be paid in connection with a particular operation.**



**Useful tip or advice**



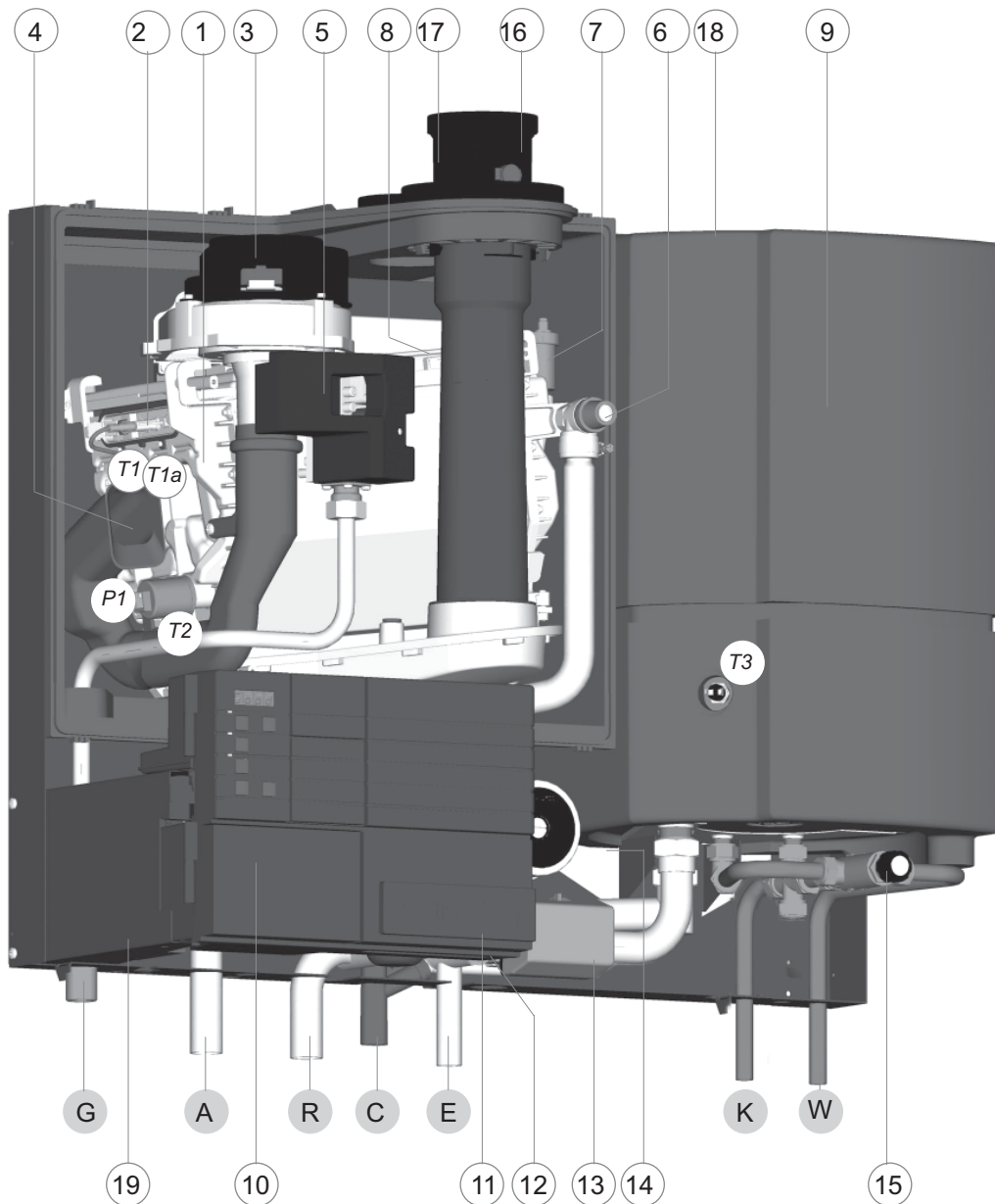

STREBEL Q

figure 4.a

- |                           |                              |                          |
|---------------------------|------------------------------|--------------------------|
| 1 heat exchanger          | 9 cylinder DHW (Combi)       | 17 combustion air supply |
| 2 ignition unit           | 10 operating panel           | 18 air box               |
| 3 fan unit                | 11 Control Tower (CMS)       | 19 type plate            |
| 4 air inlet damper        | 12 water filter return CH    |                          |
| 5 gas valve               | 13 three-way valve           |                          |
| 6 safety valve            | 14 circulation pump          |                          |
| 7 automatic air vent      | 15 thermostatic mixing valve |                          |
| 8 ceramic burner cassette | 16 flue gas discharge        |                          |

- T1 flow sensor
- T1a secondary flow sensor (Q60S)
- T2 return sensor
- T3 cylinder sensor DHW (combi)
- P1 water pressure sensor

- G gas pipe
- A flow connection central heating
- R return connection central heating
- C condensate pipe
- E expansion vessel pipe (Q51C)

- K cold water pipe (combi)
- W hot water pipe (combi)

## 5 Mounting the boiler

The room where the boiler will be placed must always be frost free.

It is NOT necessary to have a purpose provided air vent in the room or internal space in which the boiler is installed. Neither is it necessary to ventilate a cupboard or compartment in which the boiler is installed, due to the extremely low surface temperature of the boiler casing during operation. Therefore the requirements of BS 6798, Clause 12, and BS5440:2 may be disregarded.

The boiler can be mounted practically to any wall with the suspension bracket and the enclosed fixing equipment. The wall must be flat and of sufficient strength in order to be able to carry the boiler weight with its water content.

Above the boiler there must be at least 250 mm working space in order to be able to fit a coaxial flue system or a twin supply. On the left side of the boiler at least 50 mm and on the right side 10 mm must be reserved to allow fitting or removing of casing. The location of the boiler can be determined by using the template located inside the boiler packaging.



**Lift the boiler only by the boilers rear wall.**

**Lifting and carrying precautions:**

- Lift only a manageable weight, or ask for help.
- When lifting the boiler, bend the knees, and keep the back straight and feet apart.
- Do not lift and twist at the same time.
- Lift and carry the boiler close to the body.
- Wear protective clothing and gloves to protect from any sharp edges.



## 6 Connecting the boiler

The boiler has the following connection pipes;

- The central heating pipes.  
*These can be connected to the installation by means of compression fittings;*
- The gas pipe.  
*It is provided with a female thread into which the tail piece of the supplied gas isolation valve can be screwed;*
- The condensation drain pipe.  
*It consists of an oval 24 mm plastic pipe. The drain pipe can be connected to this by means of an open connection. If the open connection is fitted in a different location, then the pipe can be lengthened by means of a 32 mm PVC sleeve;*
- The flue gas exhaust system and air supply system.  
*It consists of a concentric connection 80/125 mm.*
- Cold and hot water pipes.  
**Only Combi boilers:** *These consist of 15 mm copper pipe and can be connected to the installation by means of compression fittings.*



**It is recommended that isolation valves are fitted to all heating and hot water connections to facilitate ease of future maintenance.**



**It is advisable to spray-clean all of the unit's connecting pipes and/or to spray-clean/blow-clean the installation before connecting it to the unit.**

### 6.1 Central heating system

Connect the central heating system according to the actual regulations.

The boiler pipes can be connected to the installation by means of compression fittings. Reducers should be used for connecting to thick-walled pipe (welded or threaded).



**When removing the plastic sealing caps from the pipes, contaminated testing water may be released.**

The boiler has a self-adjusting and self-protecting control system for the load and the pump capacity. This means the temperature difference between the flow and return water is checked. Table 6.1.a shows the water displacement which supplies the circulation pump at certain installation resistance.

	Boiler type	pump type	water flow rate		permissible installation resistance	
			l/min	l/h	kPa	mbar
Combi	Q25C	20-60	16,2	972	29	290
	Q38C	20-70	24,6	1478	20	200
	Q51C	20-70	30,1	1803		
	Q25S	20-60	9,7	583	47	470
	Q25S	20-60	16,2	972	32	320
Solo	Q38S	20-70	24,6	1478	22	220
	Q51S	20-70	30,1	1803		
	Q60S	20-70	38,9	2333		

Installation resistance

table 6.1.a



**A low velocity header must be connected to the Q51C, Q51S and Q60S to prevent flow problems over the boiler.**

STREBEL supplies the AA1OV09U Low velocity header for 1 boiler. This can be connected directly under the boiler on the flow and return pipe.

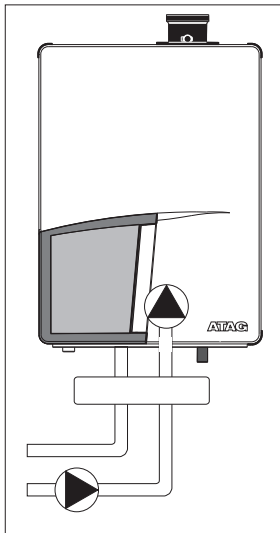

external installation pump  
with low velocity header  
figure 6.1.a

If the installation resistance is higher than the stated value the pump will rotate at maximum pump capacity and the load will be adjusted until an acceptable temperature difference between flow and return water has been obtained. If, after this, the temperature difference remains too much then the boiler will switch itself off and wait until an acceptable temperature has arisen ( $\Delta T 20^{\circ}\text{C}$ ).

If an unacceptable temperature is detected, then the control will repeatedly try to achieve water flow, and if this does not work then the boiler will switch off.

If the capacity of the boiler pump is insufficient, an extra external pump can be installed in combination with a low velocity header in series with the boiler. The electrical side of this external circulation pump can be connected in the Control Tower, which means this pump switches at the same times as the boiler pump.

The maximum absorbed current consumption of the external circulation pump may be 230 W (1 Amp). The extra external pump must be selected according to the installation resistance and required flow.

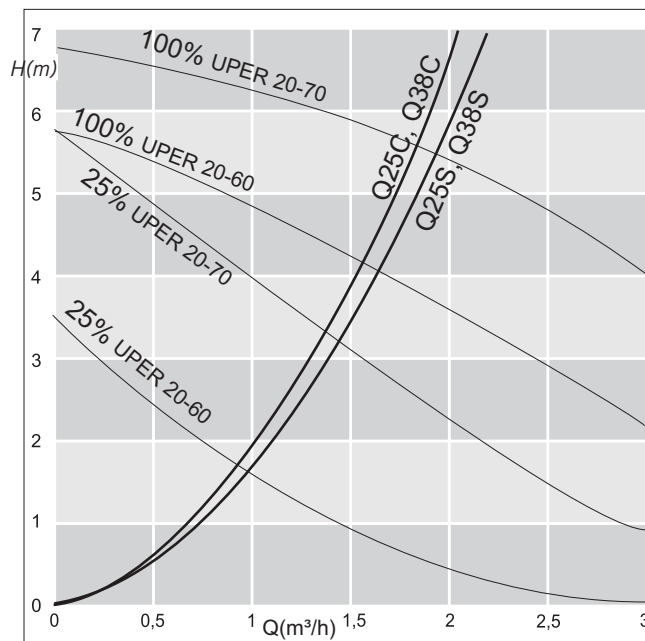

pump index lines

graph 6.1.a

As standard the boiler is provided with a water filter in the return pipe of the boiler. With this, possible contamination of the central heating water is prevented from ending up in the boiler. The boiler is also provided with an internal safety valve set at 3 bar. This is connected to the waste discharge together with the condensation discharge.

If all, or a large part of the radiators are provided with thermostatic radiator valves it is advisable to use a pressure difference control (bypass) in order to prevent flow problems in the installation.



**The boiler is designed to be used on sealed system only.**



**Additives in the installation water are only permitted in consultation with the country distributor. See chapter 6.5.**

When using more than one boiler in an installation please refer to the cascade installation instructions.

## 6.2 Expansion vessel

The central heating system must be provided with an expansion vessel. The expansion vessel which is used should be geared to the water content of the installation. The pre-charge pressure depends on the installation height above the mounted expansion vessel. See table 6.2.a.

installation height above the expansion vessel	pre-charge pressure of the expansion vessel
5 m	0,5 bar
10 m	1,0 bar
15 m	1,5 bar

choice of expansion vessel

table 6.2.a

All Combi boilers are provided with an expansion vessel connection. This pipe is connected between the three way valve and boiler pump. This prevents the expanding water, during hot water production, from being closed off from the expansion vessel, when the thermostatic radiator valves are fully closed. A second expansion vessel in the installation is not a problem.



**In connection with correct functioning of the boiler it is necessary for the expansion vessel to be connected to the expansion vessel pipe of the boiler.**

The Solo boilers are not provided with an expansion vessel connection. When one of these Solo boilers is combined with a cylinder then one has to take into account that the expansion vessel should be connected between the three-way valve and the boiler circulation pump.

## 6.3 Expansion vessel module

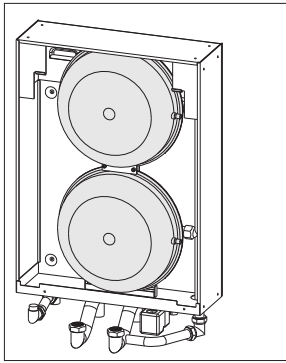

expansion vessel module  
figure 6.3.a

The STREBEL S-HQ25S and Q38S boilers can be provided with an expansion vessel module. This means the external expansion vessel is not required. This expansion vessel module is placed behind the STREBEL S-HQ boiler, which means the expansion vessel is not noticeable. The content of the two expansion vessels is 20 litres. The pre-charge pressure is 1 bar.

The expansion vessel module can be supplied with the necessary pipes to connect with the STREBEL S-HQ boiler. The connecting pipes for the installation correspond with those of the boiler and have the same centre-to-centre distance to the wall.

When checking the expansion vessels these are accessible via the left, right and upper sides. From these sides the tanks are also removable and the boiler does not have to be dismantled.

The space which is required for mounting the expansion vessel module corresponds with the required space for mounting an STREBEL S-HQ boiler. They included template and mounting strip for the boiler which can be used for the expansion vessel module. The boiler is fitted on to this after the expansion vessel module has been mounted. The necessary mounting strip for the boiler is present on the module.

Article numbers:

- the expansion vessel module without pipe connections    AEM0209U
- pipe connections for expansion vessel module            ALE0004U

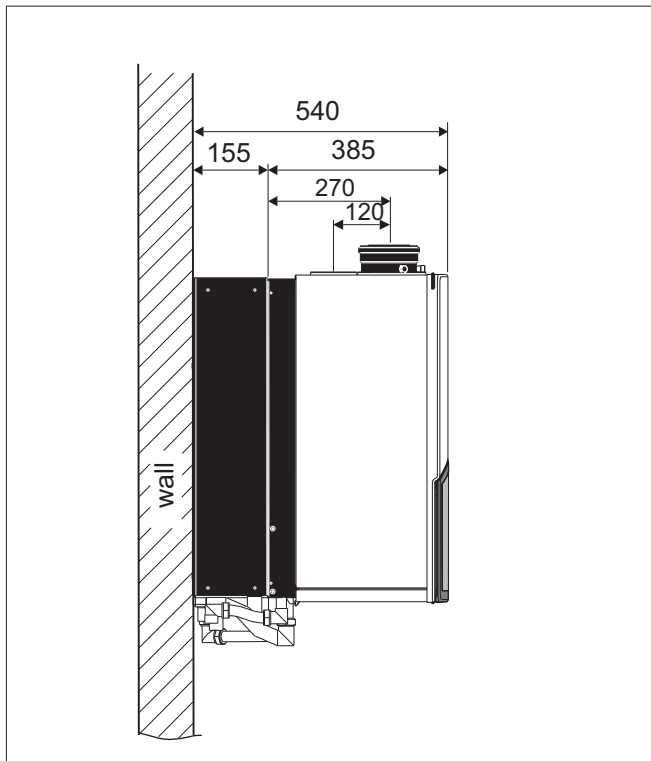

side view of the module with boiler (dimensions in mm)    figure 6.3.b

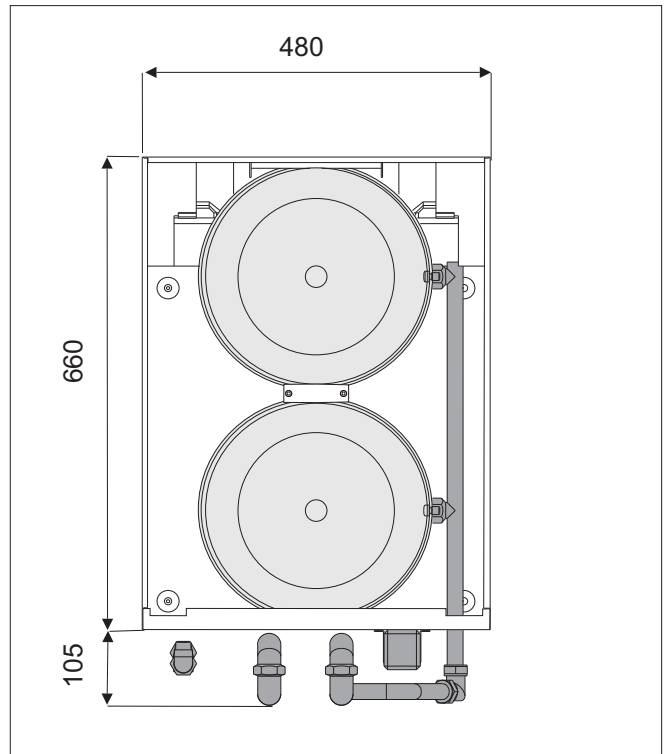

front view of the module with boiler (dimensions in mm)    figure 6.3.c

## 6.4 Underfloor heating system (plastic pipes)

When connecting or using an underfloor heating system, designed with plastic pipes, or plastic pipes are used elsewhere in the installation, one should ensure that the plastic pipes used comply with the DIN 4726/4729 standard. It is set out in this standard that the pipes may not have oxygen permeability higher than 0.1 g/m<sup>3</sup>.d at 40°C. If the system does not comply with this DIN standard, the underfloor heating component will have to be separated from the central heating appliance by means of a plate exchanger.



**No recourse can be made to the terms of the warranty in the event of failure to observe the regulations pertaining to plastic underfloor heating pipes.**

## 6.5 Water quality

Fill the installation with drinking water.

In most cases, a heating system can be filled with water according to national standards for water and treatment of this water is not necessary.

In order to avoid problems with the CH-installations, the quality of the filling water has to meet the specifications mentioned in table 6.5.a:

If the filling water does not meet the required specifications, you are advised to treat the water to such an extent that it does meet the required specifications.



**The warranty becomes invalid, if the installation is not being flushed and/or the quality of the filling water does not meet the specifications recommended by STREBEL. Always contact STREBEL in advance, if things are not clear or you wish to discuss any deviations. Without approval, the warranty becomes invalid.**

Installation:

- The use of groundwater, demi-water and distilled water is prohibited. (on the next page you will find an explanation of these definitions)
- If the drinking water quality meets the specifications mentioned in table 6.5.a, you can start flushing the installation before installing the device.
- Whilst flushing, corrosion products (magnetite), fitting products, cutting oil and other undesirable products have to be removed.
- Another possibility is to remove the pollution by installing a filter. The filter type has to fit the type and grain size of the pollution. STREBEL recommends filter usage.
- In this case, the whole piping system should be taken into consideration.
- The CH-installation has to be properly vented before using the system. For that purpose, we refer to the commissioning chapter.
- If a regularly water top up is required (>5% on an annual basis), then there is a structural problem and an installer has to solve the problem. Adding regularly fresh water to the system also adds additional calcium and oxygen implying that magnetite and calcium residues can continue. The result may be blockages and/or leakages.
- The use of anti-freeze and other additives requires periodical quality checks of the filling water in accordance with the period laid down by the additives supplier.
- Chemical additions are to be avoided and should only be used after STREBEL has approved their corresponding use.
- Should you wish to achieve the required water quality by using chemical additives, then this is your own responsibility. The warranty on the product delivered by STREBEL expires, if the water quality does not meet STREBEL's specifications or the chemical additives have not been approved by STREBEL.
- On installation and during additions or changes at a later stage, STREBEL recommends to keep a record of the type of water used, its quality at the time, and if applicable, which additives and quantities were added.

Parameter	Value
Water type	Potable water
Softened water	6.0-8.5
pH	6.0-8.5
Conductivity (at 20°C in µS/cm)	Max. 2500
Iron (ppm)	Max. 0.2
Hardness (°dH)	
Installation volume/capacity	1-7
<20 l/kW	1-12
Installation volume/capacity	Refer to Additives Attachment
>=20 l/kW	1-7
Oxygen	No oxygen diffusion allowed during operation.
Max. 5% filling water addition annually	Refer to Additives Attachment
Corrosion inhibitors	Refer to Additives Attachment
pH increasing or lowering agents	Refer to Additives Attachment
Anti-freeze additives	Refer to Additives Attachment
Other chemical additives	Refer to Additives Attachment
Solid substances	Not allowed
Residues of processing water not forming part of the drinking water	Not allowed

table 6.5.a

#### Water quality in DHW facility

Parameter	Value
Water type	Potable water
pH	7.0-9.5
Conductivity (at 20°C in µS/cm)	Max. 2500
Chloride (ppm)	Max. 150
Iron (ppm)	Max. 0.2
Hardness (°dH)	1-12
Number of bacterial colonies at 22°C (number/ml). pr EN ISO 6222	Max. 100

table 6.5.b

- When the amount of chloride is above the required specifications mentioned above in table 6.5.b, it is necessary to apply an active anode in case of the use of a DHW cylinder. If this is not met it will void the warranty for DHW parts of the installation.
- When the amount of chloride is above the required specifications mentioned above in table 6.5.b, in case of the use of a combi boiler will void the warranty for DHW parts of the boiler.

#### Water type definition:

- Potable water: Tap water compliant with the European drinking water guideline: 98/83/EG dated 3 November 1998.
- Softened water: Water with partly de-ionised calcium and magnesium.
- Demi-water: Virtually completely demineralised water (very low conductivity)
- Distilled water: Water no longer containing minerals.

## 6.6 Gas connection

The appliance pipe is fitted with an internal thread, into which the tail piece of the gas isolation valve can be screwed.

### **United Kingdom:**

The gas supply must comply to the current Gas Safety Regulations.

The connection to the appliance must include a suitable method of disconnection and a gas control cock must be installed adjacent to the appliance for isolation purposes. The nominal inlet working gas pressure measured at the appliance should be 20 mbar for Nat gas (G20).



**Make sure that the gas pipe work does not contain dirt, particularly with new pipes.**

When the boiler has to be converted from natural gas to LPG, STREBEL provides special kits for this purpose. Special instructions are supplied with the kit.



**Always check the installation of all of the parts through which gas flows using leak detection fluid (LDF).**

## 6.7 Hot water supply

Connection of the drinking water installation should be done according to the national water laws.

The sanitary water pipes can be connected to the installation by means of compression fittings. The cold water inlet on the Combi boilers must be provided with the following (counted in the water flow direction):

Dosing valve (supplied), Safety group, Expansion vessel 6bar (potable water, blue).

A dosing valve must be fitted in the cold water pipe. The dosing valve ensures that a quantity of water is supplied which has a guaranteed outlet temperature of 60°C (assuming a cold water temperature of 10°C). The quantity of water is virtually unaffected by the water pressure.



With a water pressure lower than 1.5 bar it is advisable to remove the inside mechanism of the dosing valve.

## 6.8 Condensation drain pipe

All STREBEL wall hung gas fired condensing boilers contain a syphonic condensate trap to collect and release condensate.

The amount of condensate formed is determined by the type of boilers and the water temperature produced by the boiler.

Condensate pipework.

Use plastic pipework of a diameter no less than 25mm.

### **Routing of the pipework.**

Wherever possible, the condensate pipework should be routed internally to prevent freezing.

The condensate pipework must fall at least 50mm per metre towards the outlet and take the shortest possible route

Support the pipe at least every 50 cm for near horizontal sections and 1 metre for vertical sections

### **External pipework**

The pipework should be kept to a minimum and the route as vertical as possible. Do not exceed 3 metres outside the dwelling.

The condensate pipe must be run using suitable corrosion resistant materials (eg. plastic).

Terminate as close to the ground or drain as possible (below the grating and above the water level) while still allowing for safe dispersal of the condensate.

Connection of a condensate drainage pipe to a drain may be subject to local building controls.

Pipework subjected to extreme cold or wind chill conditions should be in a 40mm diameter pipe.

Protect all external pipework with weather resistant insulation and, if necessary, box in, to reduce the risk of freezing.

### **Making it safe.**

Condensate pipework must not leak, freeze or block up.

Condensate traps must be filled before firing the boiler to prevent the possibility of potential harmful flue products evacuating via the condensate route.

Do not dispose condensate into a water recovery system where it is reclaimed for reuse.

Condensate can be discharged into a rainwater hopper which is part of a sewer carrying both rain water and foul water.



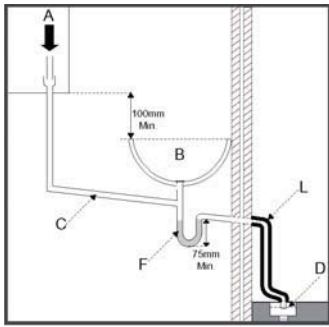

**Final discharge options.**

The condensate pipe can only terminate into any one of the five areas as shown in the diagrams on this page.



**Draining of the condensation water to the external rain guttering is not permitted in view of the danger of freezing.**



**Before putting the boiler into operation fill the syphon with 300 ml of water.**

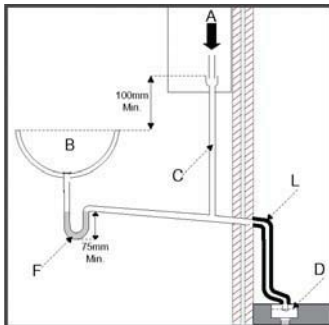
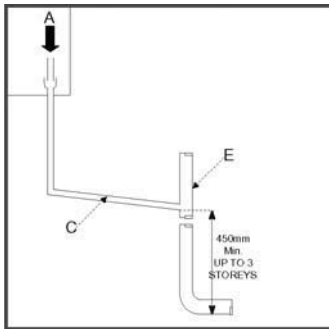
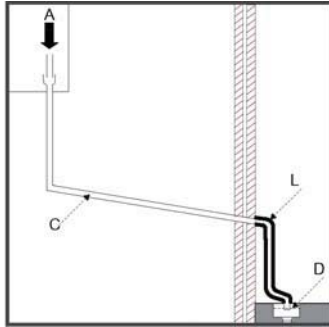

- A -Condensate from boiler syphon/trap
- B -Sink with internal overflow
- C -25mm dia. Plastic condensate pipe
- D -External drain or gully
- E -Internal soil and vent stack.
- F -Servicable condensate trap (75mm min.)
- G -300mm x 100mm dia. sealed plastic tube.
- H -Ground level
- J -Drainage holes facing away from the building
- K -Lime stone chippings
- L -Weather resistant insulation

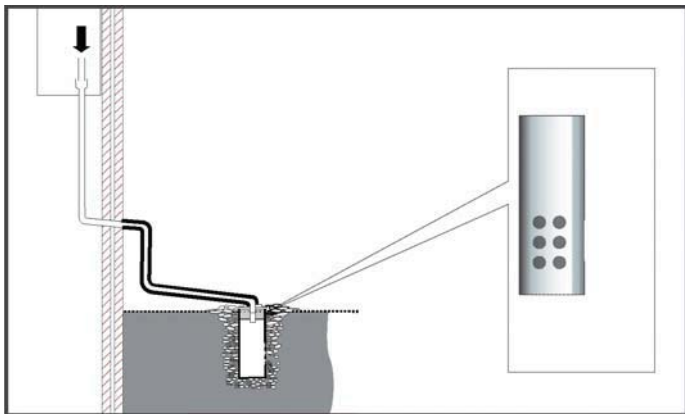

Drain requirements

figure 6.8.a

## 6.9 Flue gas exhaust system and air supply system

The flue gas exhaust system and air supply system consists of:

- Flue gas pipe;
- Air supply pipe;
- Roof or wall terminal.

The flue gas exhaust system and air supply system must comply with:

### **United Kingdom:**

The flue gas outlet and air supply installation must comply with the current regulation requirements:

IGE/UP/10;	Installation of flued gas appliances in industrial and commercial premises
BS EN 1856-1;	Chimneys - Requirements for metal chimneys - Part 1: System chimney products
BS EN 1856-2;	Chimneys - Requirements for metal chimneys - Part 2: Metal liners and connecting flue pipes
BS EN 15287-1;	Chimneys - Design, installation and commissioning of chimneys - Part 1: Chimneys for non-room sealed appliances
BS EN 15287-2;	Chimneys - Design, installation and commissioning of chimneys - Part 1: Chimneys for room sealed appliances
BS EN 13384-2;	Chimney - Thermal and fluid dynamic calculation methods - Part 2: Chimneys serving more than one heating appliance
Clean Air Act;	For multiple boiler application where total heat input exceeds 366.4 kW [ or 150 kW as advised within the CAAM, refer to local authority ]

Furthermore:

- **Boiler Class indicated on the boiler's type plate (Flue category)**
- Locally applicable rules.
- The supplier's installation instructions

**When in doubt or if you have any questions, always contact STREBEL Ltd..**

The boiler can be fitted with a parallel connected flue gas outlet and air supply system (the connection diameter for both channels is  $\varnothing 100\text{mm}$ ) or a concentric flue gas outlet and air supply system. In that case, the connection diameter is  $\varnothing 100/150\text{mm}$ . Refer to chapter 7.1 or 7.2.

The appliance connection diameter is 80/125 mm, to which the flue gas outlet and air supply system can be fitted, with or without elbow pieces. The maximum permissible pipe length is set out in Table 6.9.1.a.

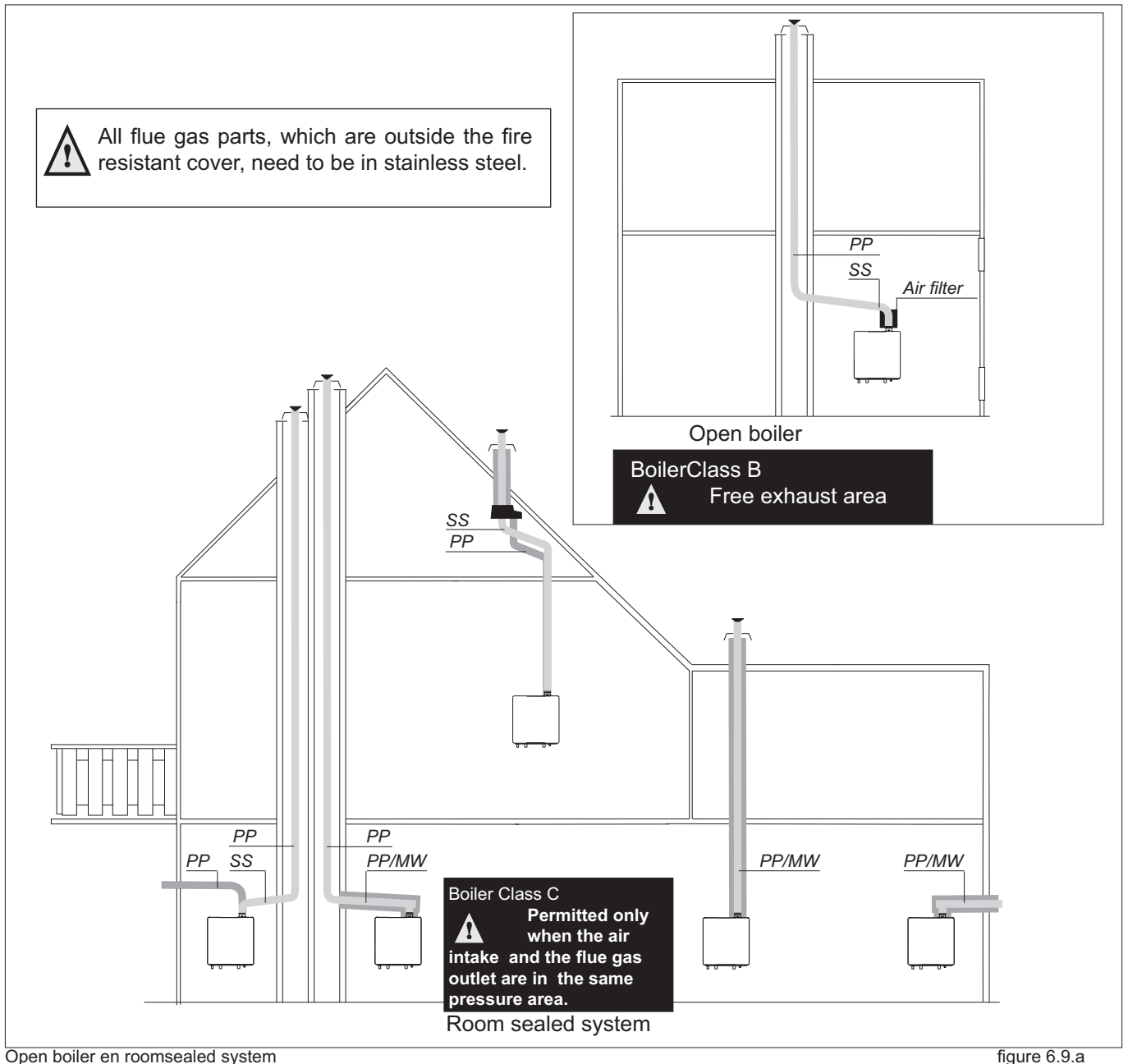

Open boiler en roomsealed system

figure 6.9.a

### **Boiler conversion from concentric to parallel**

It is also possible to use a parallel pipe connection of 2x 80mm. In this case a conversion kit 'concentric to parallel' should be ordered. Art.nr. S4440520.

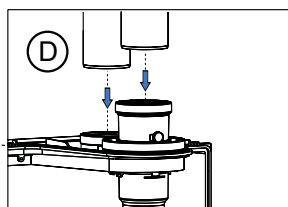
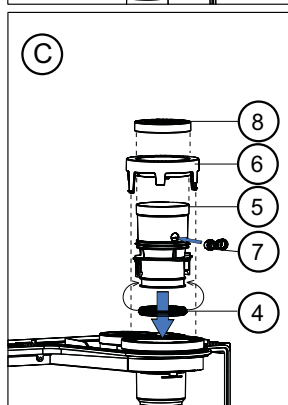
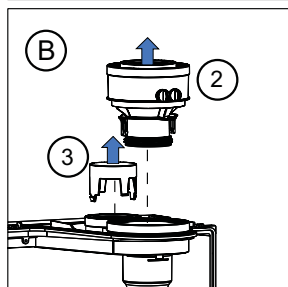
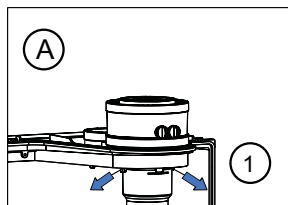

- A. 1. Push the 2 clips slightly outwards.
- B. 2. Pull the concentric adaptor out of the boiler.  
3. Press the cover in the connection at the back from inside out.
- C. 4. Pull the rubber seal around the bottom of the flue connector.  
5. Push the flue connector in the boiler, in the boiler flue pipe until 'CLICK'.  
6. Push the  $\varnothing 125\text{mm}$  cover over the flue connector in the  $\varnothing 125\text{mm}$  opening until 'CLICK'.  
7. Push the rubber plug in open position in the  $\text{O}_2$  measuring opening and close the stop.  
8. Push the gasket around the top of the flue connector.
- D. Connect the parallel flue gas and air intake system (2x  $\varnothing 80\text{mm}$ ).

boiler conversion from  
concentric to parallel  
figure 6.9.a



We advise to build a simple flue gas system and air supply system out of table 6. For further information about the available components of the flue gas and air supply system we recommend you consult STREBEL Ltd..

The STREBEL flue gas system is meant and designed solely the use on STREBEL central heating boilers adjusted for Nat gas or LPG. The maximum flue gas temperatures are below 70°C (full load 80/60°C)

The proper operation can be influenced harmfully by changes of or adjustments to the correct set up.

Possible warranty claims will not be honoured if incorrect changes result in non compliance with the installation manual or local rules and regulations.

The flue gas systems described in this document are solely suited for STREBEL central heating boilers of the STREBEL boiler range. For this purpose the CE Certificate has been supplemented under the Gastec nr: 0063BQ3021, 0063AS3538 and 0063AU3110. The flue gas system should be built up using only STREBEL program products.

Horizontal flue system should always be installed sloping towards the boiler, in order to avoid condensate lying in the flue system.

The minimum gradient is 50mm/Mtr. With the condensate running back to the boiler the risk of ice forming at the terminal is reduced.

The terminal should be located where dispersal of combustion products is not impeded and with due regard for the damage or discolouration that might occur to building products in the vicinity (see fig 6.9.b).

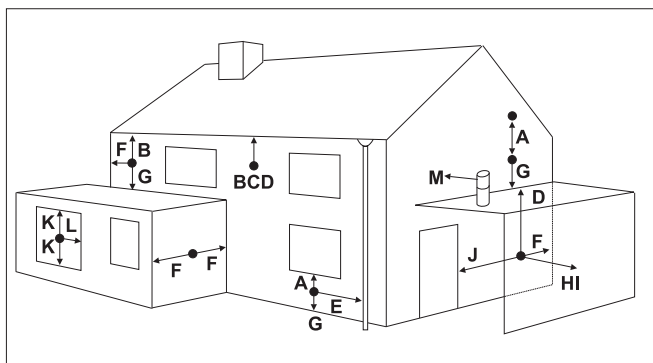

figure 6.9.b

terminal position for fan assisted boiler		minimum distance
A	directly below an open window or other opening (e.g. air brick)	mm 300
B	below gutters, soil pipes or drain pipes	mm 75
C	below eaves	mm 200
D	below balconies or car port roof	mm 200
E	from vertical drain pipes and soil pipes	mm 75
F	from internal or external corners	mm 300
G	above ground or below balcony level	mm 300
H	from a surface facing a terminal	mm 600
I	from a terminal facing a terminal	mm 1200
J	from an opening in the car port (e.g. door window) into dwelling	mm 1200
K	vertically from a terminal on the same wall	mm 1500
L	horizontally from a terminal on the same wall	mm 300
M	horizontally from a vertical terminal to a wall	mm 300

Dimensions

table 6.9.a

In certain weather conditions condensation may also accumulate on the outside of the air inlet pipe. Such conditions must be considered and where necessary insulation of the inlet pipe may be required.

In cold and/or humid weather water vapour may condense on leaving the flue terminal. The effect of such 'plumeing' must be considered.

The terminal must not be located in a place where it is likely to cause a nuisance.

For protection of combustibles, refer to IS 813 section 9.10.1. where the terminal is less than 2m (6.6ft) above a pavement or platform to which people have access (including any balcony or flat roof the terminal must be protected by a guard of durable material. A suitable guard is available from the country distributor.



**Where a terminal is fitted below a window which is hinged at the top, and where the hinge axis is horizontal, and the window opens outwards, the terminal shall be 1m below the bottom of the window opening.**



**If the boiler is to be located under stairs, a smoke alarm meeting the requirements of I.S. 409 or equivalent must be fitted.**



**The flue must be terminated in a place not likely to cause a nuisance.**

For horizontal sections, the outlet system should always be fitted on an incline (50 mm/m) sloping down towards the appliance so that no condensation water is able to accumulate in the outlet system. The chances of icicles forming on the roof outlet is minimised by causing the condensation water to run back towards the appliance. In the case of horizontal outlets the inlet system should be fitted on an incline sloping down towards the outside to prevent rainwater from coming in.

The appliance produces a white wisp of condensation (plumeing). This wisp of condensation is harmless, but can be unattractive, particularly in the case of outlets in outside walls.

Cutting the pipe goes as follows:

- Take out the inner tube by turning it until it releases from its security position;
- Cut just as much from the air intake part as from the flue gas part;
- Take off the burrs from the cutting edge to prevent cutting the seals;
- Click the pipes back together again.

Use special grease to simplify the fitting

When mounting the flue gas system, pay attention to the flow direction. An arrow on the product points this out. It is not permitted to mount a system upside down and will lead to complaints.

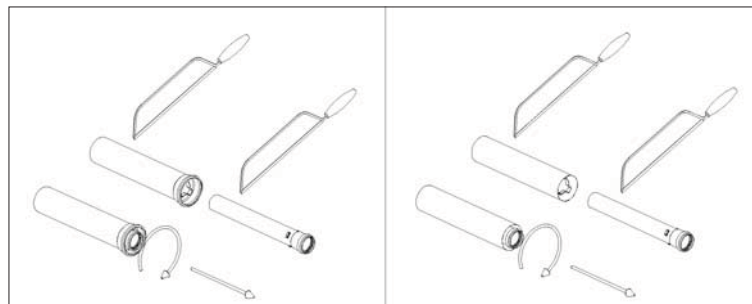
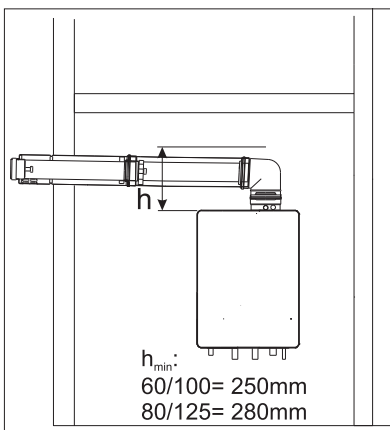

*Dismantlement and shorten pipes*

*figure 6.9.c*

## 6.9.1 Dimensioning of the flue gas and air intake duct

The flue diameter is determined by the total length of the run, including for the connection pipe, elbows fittings and terminal covers etc and the type and number of boilers installed into the system.

An undersized flue pipe can lead to disorders. Look at table 6.9.1.a for the choice of the system and the correct diameter. The table below shows the maximum flue lengths with the different boiler outputs. A longer flue gas length can be achieved by increasing the diameter to  $\varnothing$  100mm.

Explanation table 6.9.1.a:

Two pipe flue gas system: maximum noted length = distance between boiler and roof terminal A

Concentric flue gas system: maximum noted length = distance between boiler and roof terminal B

When using bends the noted value behind every bend should be deducted from the maximum straight length.

Example:

A 25kW with a concentric flue gas system  $\varnothing$ 80/125mm has according to the table a maximum flue straight length of 31m In the system that is going to be put in there are 2 x 45° bends, so the maximum flue gas length is  $31 - (2 \times 1.1) = 28.8$  meters.

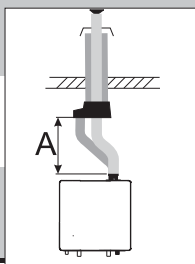
Two pipe flue system + chimney lining					
		$\varnothing$ 80mm		$\varnothing$ 100mm	
		A	A	A	A
		in m		in m	
16-25 kW		Maximum straight length 80	31	Maximum straight length 100	40
		87° bend resistance length	-1,5	87° bend resistance length	-1,8
		45° bend resistance length	-0,8	45° bend resistance length	-0,9
26-38 kW		Maximum straight length 80	18	Maximum straight length 100	39
		87° bend resistance length	-1,5	87° bend resistance length	-1,8
		45° bend resistance length	-0,8	45° bend resistance length	-0,9
39-60 kW		Maximum straight length 80	6	Maximum straight length 100	18
		87° bend resistance length	-1,5	87° bend resistance length	-1,8
		45° bend resistance length	-0,8	45° bend resistance length	-0,9

Concentric flue system							
	$\varnothing$ 60/100mm		$\varnothing$ 80/125mm		$\varnothing$ 100/150mm		
	B	B	B	B	B	B	
	in m		in m		in m		
16-25 kW		Maximum straight length 60/100	12	Maximum straight length 80/125	31	Maximum straight length 100/150	40
		87° bend resistance length	-1	87° bend resistance length	-2,8	87° bend resistance length	-2,6
		45° bend resistance length	-1	45° bend resistance length	-1,1	45° bend resistance length	-1,1
26-38 kW		Maximum straight length 80/125	13	Maximum straight length 100/150	34		
		87° bend resistance length	-2,8	87° bend resistance length	-2,6		
		45° bend resistance length	-1,1	45° bend resistance length	-1,1		
39-60 kW		Maximum straight length 80/125	6	Maximum straight length 100/150	10		
		87° bend resistance length	-2,8	87° bend resistance length	-2,6		
		45° bend resistance length	-1,1	45° bend resistance length	-1,1		

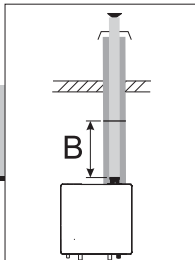
Dimensions flue gas system and air supply system

Table 6.9.1.a

## 7 External hot water cylinders

Depending of the comfort preferences different external hot water cylinders can be connected to the boiler. The choice of the cylinder depends on the coil output. The coil output must comply with the boiler output.

A cylinder which is used in combination with a Q 51S or Q 60S, should have a minimal capacity of 40 kW resp. 45kW (minimal  $\varnothing$ 28mm coil). The maximum permitted pressure drop is respectively 20 and 10 kPa at a flow of respectively 1417 and 1587 l/h. See installation example 17.2 on page 40 for the hydraulic connection.



## 8 Electrical connection

The appliance complies with the CE Machinery Directive 89/392/EEC. The EC Low Voltage Directive 72/23/EEC and the EC EMC Directive 89/336/EEC.  
A 230V -50Hz mains electrical supply is required fused externally at 5A.

The installation must continue to comply with:

**United Kingdom:**

- the national rules for electrical installations.

The appliance must be connected to an earthed socket. this must be visible and within reach.

The following general stipulations also apply:

- No changes may be made to the wiring of the appliance;
- All connections should be designed in accordance with the enclosed regulations.;
- Should it be necessary to change it, the mains power supply cable may only be replaced with an STREBEL mains power supply cable (item No. S4407300).

**The STREBEL room thermostat and controls must be connected to their allocated connections. All other types or makes of room thermostats or controls which are used must have a Volt free contact.**

When using an on/off thermostat or control, it is possible that an anticipating resistance must be installed in order to prevent too high temperature fluctuations. As a standard rule this means mercury thermostats. This resistance wire is present in the Control Tower and must be connected to clamps 23 and 27. The anticipating resistance in the room thermostat has to be set at 0.11 A.

For more detailed questions regarding the components which are not supplied, the country distributor should be contacted.

Connection terminalQ																											
230 V~ Power Supply			230 V~ External Pump			230 V~ External Controller			230 V~			8C,35,22,03	Calorifier connection three-way valve				DHW sensor	Outside sensor		Bus therm.		Room therm. On / Off		External safety contact		24 V~ 100 mA	
N	L		N	L		N	L		N	L			CH	DHW	N					A	B						
1	2	3	4	5	6	7	8	9	10	11			12	13	14	15		16	17	18	19	20	21	22	23	24	25
mains power supply			230 Volts for external pump			230 Volts for external control			230 Volts			internal or external three-way valve motor and cylinder sensor				outside sensor		room thermostat		On/off thermostat or control (Volt free)		External safety contact		24 Volts maximum 100 mA			

Connection terminal

figure 8.a

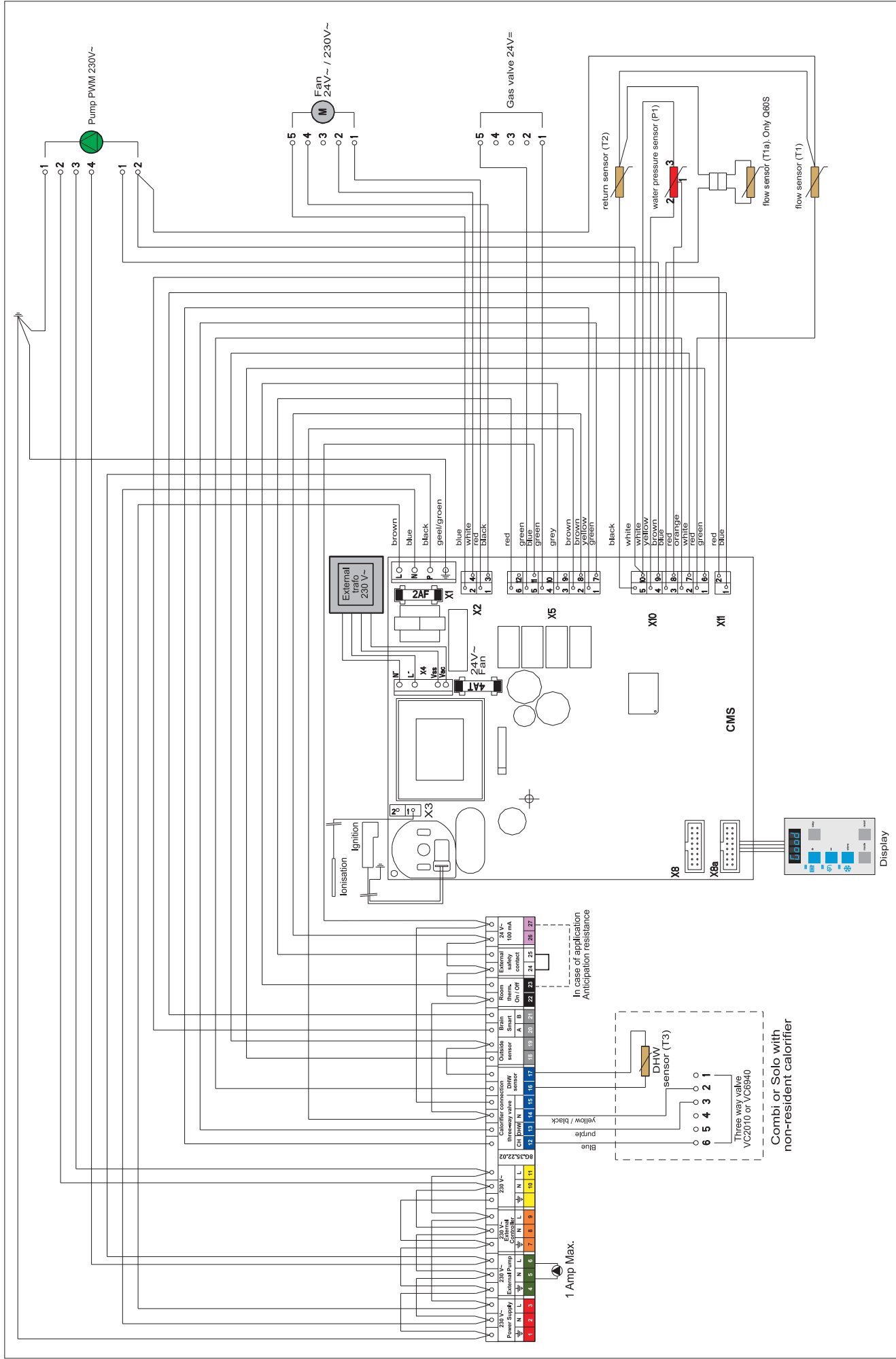

electrical diagram

figure 8.b

## 9 Boiler controls

The boiler is provided with a fully automatic microprocessor control, called CMS Control Management System. This control simplifies operation by undertaking all major control functions. Initially when power to the unit is switched on it will remain on standby. There is no indication Led on, until one of the programme keys is pressed. The control panel display will show the relevant state. When the installation is empty the display will show FILL.

The various parameters can be called up in two ways:

### The Good-state or standard read out

The first way shows a simple display read out.

The boiler in operation will always show 'Good'. When a message is necessary this will be shown instead of Good.

### Technical read out

The second way is a technical read out. In normal situations the following will be shown:

- on the left the status in which the boiler is active;
- on the right the flow temperature;
- the water pressure in the installation.

When a message (error or blocking code) is necessary this will be shown instead of the technical read out..



**To switch over from the Good-state to the Technical read out (and vice versa):  
- Press 5 sec. on the STEP-key.**

When the system has been filled the automatic venting program starts, when a programme has been selected, by pressing the key for Central Heating, DHW or pump programme (▣▣▣▣, ☞ or ❄). The programme takes 17 minutes and stops automatically. After this the unit will function normally. (See also 'Filling and venting the boiler and installation).

On a call for heating or hot water the control system will select the required water control temperature. This water temperature is called the T-set value. On a call for central heating the boiler ignites first at low input. The input is then changed slowly to match the load required. The boiler operates in this way to avoid excessive water noises and temperature overshoot. On a call for hot water supply the T-set value of central heating return water temperature is monitored. Depending on the amount of sanitary water which is withdrawn from the DHW cylinder, the central heating return water temperature, from which the input is adjusted, will vary.

## 9.1 Explanation of the function keys



- Central Heating programme key.  
Switching the Central Heating on or off (Led on/off);



- Hot Water programme key.  
Switching the Domestig Hot Water (DHW) facility on or off (Led on/off);



- Pump programme key.  
adjusts the pump to continuous water circulation in the central heating system (Led on), or according to the pump overrun times on the relevant programs (Led off);

When the pump is switched on continuously it can lead to undesired heating up of the central heating system during the summer.

- **Mode-key.**  
*After briefly pressing, a selection of the data chapters can be retrieved.  
After pressing for 5 seconds it is possible to enter the code as described in chapter 11.3;*
- **Step-key.**  
*After briefly pressing, the water pressure can be retrieved and pages per chapter can be retrieved.  
After pressing for 5 seconds it switches from the Good-state to technical read out and vice versa;*
- **Reset-key.**  
*After briefly pressing, for:*
  - *unlocking errors;*
  - *ending the access code;**After pressing for 5 seconds an operating stop is made, for example, for activating the automatic venting programme.*



Some keys have other functions. These functions are only active when according to the procedure described in chapter 11.3, adjustment has to be changed or data must be retrieved from the CMS.

The other functions are:

- Central Heating programme key : + function;
- Hot Water programme key: - function;
- Pump programme key : store-function; a modified setting is confirmed;
- Step-key: scrolling in a data chapter.

## 10 Filling and venting the boiler and installation

The central heating installation needs to be filled with potable water. For filling or topping up the installation you use the filling loop according to the following procedure:

- 1 Switch on the power supply;
- 2 The display will show FILL;
- 3 All functions off (heating, DHW and pump);
- 4 Push briefly the 'STEP'-button: P x.x = water pressure in bar;
- 5 Open the filling loop (Indication on display increases);
- 6 Fill up slowly to 1.5 to 1.7 bar;
- 7 STOP appears on the display;
- 8 Close the filling loop;
- 9 De-aerate the complete installation, start at the lowest point;
- 10 Check the water pressure and if necessary top it up;
- 11 Close the filling loop;
- 12 Activate the functions in use (heating , DHW  and/or pump  );
- 13 If A xx appears on the display, wait for 17 minutes;
- 14 Check the water pressure and if necessary top it up to 1,5 to 1,7 bar
- 15 Close the filling loop;
- 16 Press the 'STEP'-button;
- 17 Be sure that the filling loop is closed.
- 18 After the automatic de-aeration programm (A xx) is finished the boiler will return to the Good state or Technical read out.

Check the water pressure regularly and top up the installation when necessary. The working pressure of the installation should be between 1.5 and 1.7 bar when the installation is cold.



**It can take a while before all air has disappeared from a filled installation. Especially in the first week noises may be heard which indicate the presence of air. The automatic air vent in the boiler will make this air disappear, which means the water pressure can reduce during this period and therefore topping up with water will have to be done.**

### 10.1 Hot water supply

Apply the water pipe pressure to the cylinder (open main valve and/or stop valve of the safety group).

Vent the cylinder and the hot water installation by opening a hot water tap. Leave the tap open for as long as required until all air has disappeared from the cylinder and the pipes and only water is flowing from the tap.

## 11 Commissioning the boiler

Before the boiler is fired, ensure that the boiler and the system are well vented and free of air. Purge the gas line between the gas meter and the boiler and carry out a gas soundness test as specified in the current Gas Safety Regulations.

The boiler does not require adjustment of the burner pressure and air quantity because it is self adjusting and is factory set at the correct value.

### 11.1 Central Heating system

Provided there is a heat requirement from the thermostat or control, the central heating programme will be put into operation by means of the  key (central heating programme). The circulation pump will start circulating and the boiler will start the burner.

### 11.2 Hot water supply

Provided there is a heat requirement from the cylinder the hot water programme will be put into operation by means of the  key (hot water programme).



**Depending on pipework and wiring configurations the boiler will operate with a priority to hot water.**

## 11.3 Adjustments

When the boiler is installed it is in principal ready for use. All adjustments of the boiler control are already pre-programmed for a heating system with radiators with large surface areas or underfloor heating as additional heatings with a flow temperature of 70°C. The adjustments are described in the Parameter chapter on page 31.

In certain cases adjustment have to be altered in case of :

- Lower flow temperature
- More boilers in Cascade, i.e..

Read through the Parameter chapter to adjust the boiler to its installation. Contact STREBEL Ltd. in case of doubt.

Please follow next procedure to alter adjustments:

### Altering adjustments

**STEP 1** Press the **Mode-key** for **5 seconds**.

*The display shows COdE followed by an arbitrary number;*

**STEP 2** Press by means of the **+** or the **-** key until the code **C123** is shown;

**STEP 3** Press the **STORE-key** to confirm the code (code blinks 1 x).

*Now you have access to the installer level. There are 4 chapters:*

- *PARA*                      *Parameters*
- *INFO*                      *Information chapter (no adjustments possible)*
- *SERV*                      *Service chapter*
- *ERR0*                      *Error-chapter (no adjustments possible)*

*The content of the chapters is described on the following pages.*

**STEP 4** Press briefly the **MODE-key** to select one of the 4 chapters, i.e. **PARA**;

**STEP 5** Press once or more briefly on the **STEP-key** to select a Parameter  
*(parameter visible on the left, value on the right) ;*

**STEP 6** Alter the value, if necessary/possible, by means of the **+** or the **-** key

**STEP 7** Press briefly on the **STORE-key** to confirm the alteration.

*When you have to change more values, repeat from step 5.*

**STEP 8** Press once or more on the **MODE-key** until **StBY** or **Good** is shown:

*After a few seconds the text StBY will be replaced by the technical read-out or Good-state (Depending from the position the access code is keyed in)*

When you want to return from an arbitrary position to the original read out press once or more on the **MODE-key** until **StBY** is shown.



After 20 minutes, if no single key is used the display will return automatically to its original read-out (Good state or technical read out)

Parameter-Mode			
PARA	Factory	Description	Range
1	70°C	maximum flow temperature CH	20 - 85°C
2*	02	type of CH installation:	
		<i>radiators; air heating; convectors:</i>	01
		<i>T max. flow 85°C; K factor heating line 2.3; gradient 5°C/min; gear differential 6°C</i>	
		<i>radiators with large surface areas or underfloor heating as additional heating:</i>	02
		<i>T max. flow 70°C; K factor heating line 1.8; gradient 5°C/min; gear differential 5°C</i>	
		<i>under floor heating with radiators as additional heating:</i>	03
		<i>T max. flow 60°C; K factor heating line 1.5; gradient 4°C/min; gear differential 4°C</i>	
		<i>full under floor heating:</i>	04
		<i>T max. flow 50°C; K factor heating line 1.0; gradient 3°C/min; gear differential 3°C</i>	
3	max.	maximum power CH in kW	min-max
4*	00	control principal with on / off thermostat:	
		100 % on / off thermostat	00
		100 % on / off weather dependant	01
5*	2.3	heating line K-factor (see also heating line graph)	0.2 - 3.5
6*	1.4	heating line exponent (see also heating line graph)	1.1 - 1.4
7*	-10	heating line climate zone (see also heating line graph)	-20 - 0
10*	0°C	fine adjustment heating line day temperature	-5 to 5°C
11*	0°C	fine adjustment heating line night temperature	-5 to 5°C
14	5	gradient speed	0 - 15
15*	0	booster after night reduction:	
		no	00
		yes	01
23	-3°C	Frost Temperature	-20 to 10°C
27	0°C	Min. flow temperature	0 to 70°C
31	63°C	Cylinder temperature with external cylinder sensor	40 - 80°C
36	0	Type of three way valve cylinder	
		VC 2010 / VC 8010	00
		VC 6940	01
43	max.	Maximum power DHW in kW	min-max
45	0	No function	00 - 01
48	25% (50%)	Minimum pump capacity (Q60S)	25-100 %
49	100%	Maximum pump capacity Heating	40-100 %
60	03	Type of communication bus:	
		Automatic recognition of ATAG Bus or ATAG Z-Bus (30 Seconds waiting time after connecting BrainQ RSC thermostat)	01
		ATAG Z-Bus	02
		ATAG Bus (BrainQ and MadQ)	03
89	00	Address of boiler in cascade	
		No function	-01
		ATAG Bus thermostat (BrainQ, MadQ)	00
		Cascade boiler 1 to 8 (Always set Par. 60 to 03)	00 - 07

Info-Mode			
INFO	Factory	Description	
1	°C	flow water temperature T1	
4	°C	return water temperature T2	
5	°C	DHW temperature T3	
7	°C	outside temperature T4	
8	°C	flow water temperature T1a	
16	%	actual power in %	
17	kW	actual power in kW	
18	kW	actual load in kW	
20		indication bus communication	
21	GJ	consumption total in GJ (.. x 33 = .. m <sup>3</sup> )	
22	GJ	consumption CH in GJ (.. x 33 = .. m <sup>3</sup> )	
23	GJ	consumption DHW in GJ (.. x 33 = .. m <sup>3</sup> )	
24	Std	total number of burner run hours	
25	Std	number of burner run hours CH	
26	Std	number of burner run hours DHW	
32	Std	total number of hours counter	
37	Std	total number of run hours pump CH and DHW	
46	Std	within how many hours is service required	
48	0,1µA	Ionisation current	



Service-Mode			
SERV	Value	Description	Range
1	OFF	boiler in operation with burner function on	OFF - max.
2	OFF	fan adjustable and burner off	OFF - max.
3	OFF	pump adjustable with burner on	OFF - max.
4	OFF	showroom position ON = active and OFF = non active	ON - OFF

Error-Mode		
ERRO	Value	Description
Err.L - Err.5		Last saved error until 5 last predecesing errors
1		error code
2		operation status boiler
3	°C	flow water temperature T1
4	°C	return water temperature T2
5	kW	load
6	%	pump capacity

Parameter-, Info-, Service- and Error-chapters

Table 11.3.a

\* Most of the data in this table can be requested by the BrainQ. Most of the adjustments which are stated in this table are unnecessary when in combination with the BrainQ thermostat and will be taken care of by the BrainQ itself and do not have to be adjusted. For further information regarding to the BrainQ thermostat we refer to the BrainQ installation manual.

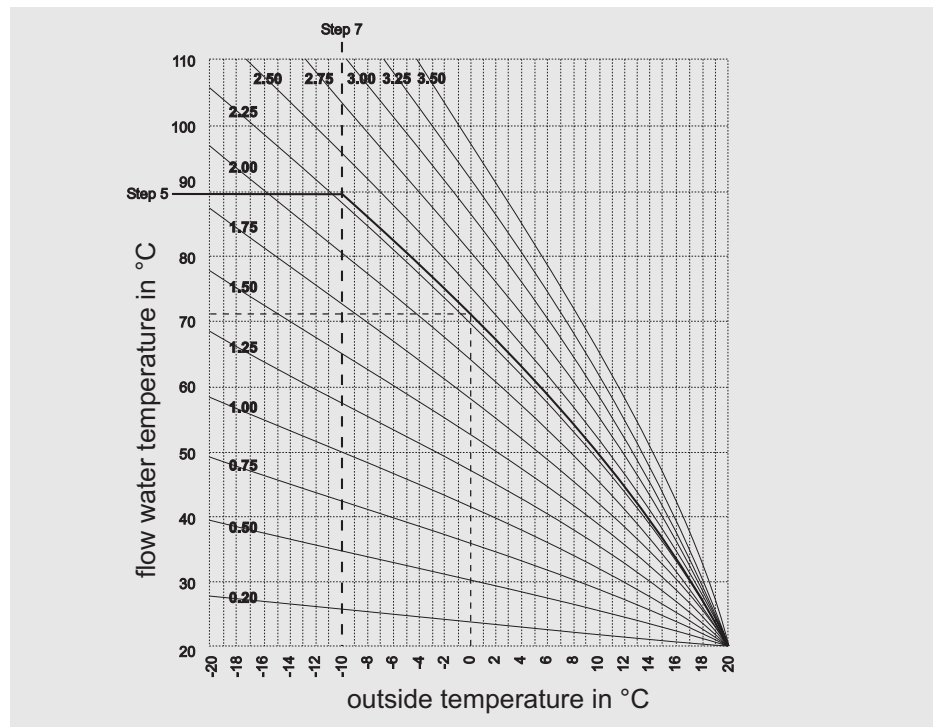

heating line adjustments Parameter Step 6 and 7

graph 11.3.a



## 11.4 Activating factory settings (green key function)

To activate the factory settings again please follow the next procedure (Note: all altered adjustments will be set back):

- Select, when necessary, the technical read out;
- Select with the MODE-key chapter PARA;
- Press the STORE-key.

The word "Copy" will appear and the factory settings are active again.

## 12 Isolating the boiler

In some situations it may be that the entire boiler must be switched off. By switching off the three keys with the lamps for central heating, hot water and pump programme ( ,  or  ), the boiler is switched off. Leave the plug in the wall socket, which means the circulation pump and the three-way valve are activated once every 24 hours in order to prevent jamming.



**In the event of frost danger it is advisable to drain the boiler and/or the installation.**

## 13 Commissioning



**Work on the boiler must be carried out by a competent person, (Ref: Gas Safety Installation, Use and Regulations )** using correctly calibrated instruments with current test certification.



**At the time of commissioning, complete all relevant sections of the Benchmark Checklist located on the inside back pages of the document.**

To commission the boiler the casing has to be removed. The casing is locked with a screw behind the door on the front and the top of the casing is hooked behind a locking edge. After removing this screw the casing must be lifted at the bottom by which means it is released from the locking edge. Then the casing can be removed forward.

The boiler settings, such as burner pressure and adjustment of the air quantity are unnecessary, due to the fact that the boiler operates with a so-called zero pressure control. This means the correct gas quantity is controlled by the suction operation of the fan. The fine adjustment which is carried out at the factory is once-only, which means that adjusting of these values is unnecessary. Only in case of replacing of the gas valve, venturi and/or fan the zero pressure and the incorrect O<sub>2</sub> adjustment has to be checked and, if necessary, adjusted at the right value.



**Always check the installation of all parts through which gas flows using leak detection fluid (LDF)**

## 13.1 Checking for contamination

In order to be able to check the boiler for contamination in the following years it is advisable to measure the maximum air displacement in the boiler when putting the boiler into operation. This value can be different with each type of boiler.

In order to be able to measure this value follow the next procedure:

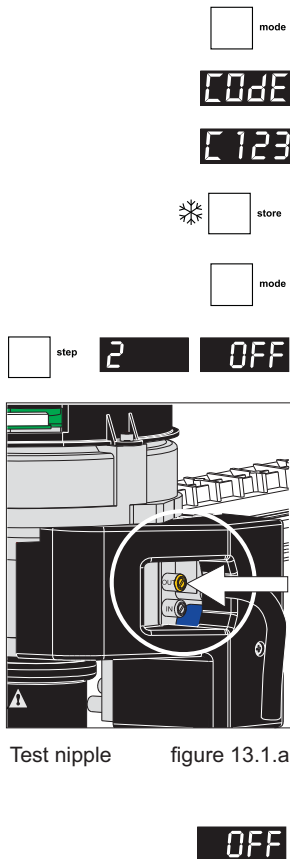

Test nipple figure 13.1.a

- Press the MODE-key for 5 seconds.
- The display will show COdE followed by an arbitrary number;
- Select by means of the + or the - key the code C123;
- Press the Store-key to confirm the code (code blinks 1 x);
- Press the MODE-key until SERV is shown;
- Press the STEP-key until 2 is shown; alternately 2 and OFF will be shown.
- Undo the top test nipple on the gas valve (fig. 13.1.a);
- Connect the hose of the digital pressure gauge to the top test nipple of the gas valve
- Press the + key until the maximum value is achieved; The fan will function to its maximum revolutions (burner stays off)
- Measure the under pressure and write down this value. At the next service visit this value may drop by 20% of its original value recorded on commissioning. If this value has dropped by more than 20% the boiler requires full maintenance.
- Press the - key until OFF is shown (keep key pressed) With this the procedure is finished.

## 13.2 Checking the O<sub>2</sub>



The O<sub>2</sub> percentage is factory-set. This has to be checked at commissioning, maintenance and faults.

This can be checked by means of the following procedure:

- Remove the black cover of the gas valve by unscrewing the sealed screw.
- Put the boiler into operation and take care that it can deliver its heat;



Tip: If there is no demand for heat on CH, turn the hot water tap completely open and measure the O<sub>2</sub>.



- Press the MODE-key for 5 seconds.



- The display will show COdE followed by an arbitrary number;



- Select by means of the + or the - key the code C123;



- Press the Store-key to confirm the code (code blinks 1 x);



- Press the MODE-key until SERV is shown;



- Press the STEP-key once until 1 is shown; alternately 1 and OFF will be shown.

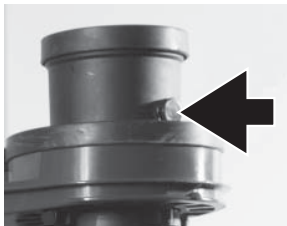

checkpoint O<sub>2</sub>

figure 13.2.a

- Calibrate the O<sub>2</sub> meter ;
- Place the lance of the O<sub>2</sub> meter into the check point (see fig. 13.2.a);
- Press the + key until the maximum value (in kW) is achieved;  
The boiler will burn on full load (value on display in kW)

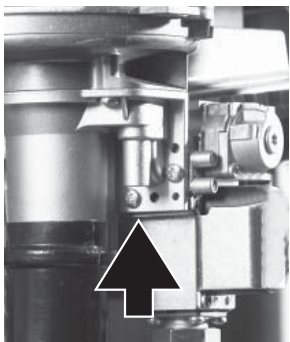

adjustment screw O<sub>2</sub>

figure 13.2.b

- O<sub>2</sub> percentage = 

Natural gas	Propane
4,7% (-1,2%, +0,8%)	5,1% (-1,2%, +0,7%)
- Let the O<sub>2</sub> meter do its measuring procedure.
- Adjust, if necessary, the adjustment screw to correct the O<sub>2</sub> value (see fig. 13.2.b).

Ending the O<sub>2</sub> measuring procedure:



- Press the - key until OFF is shown (keep key pressed).  
With this the procedure has ended..
- Replace the black cover on the gas valve and fix it with the screw.

## 13.3 Maintenance activities

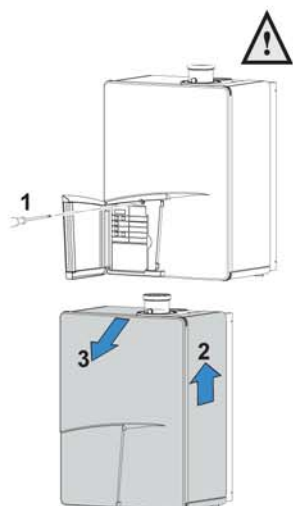

Removing casing  
figure 13.3.a

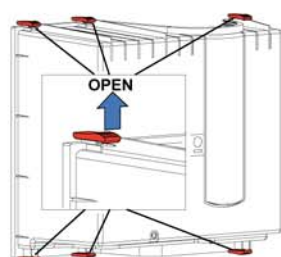

Opening air box  
figure 13.3.b

**The maintenance should be carried out every year.**

To carry out the maintenance activities please follow the next procedure:

- switch off the power supply;
- remove the screw behind the door on the front of the casing (see fig. 13.3.b);
- Lift the casing and remove it towards the front.

### The air box

- remove the transparent air box (see fig. 13.3.b);
- clean the box with a cloth with a simple (non-abrasive) cleaning agent;

### The fan unit and burner cassette (see fig. 13.3.c and d)

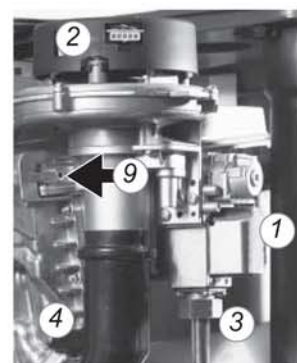

fan unit and gas valve  
figure 13.3.c

- remove the electrical connection plug from the gas valve (1) and fan motor (2);
- loosen the nut (3) of the gas pipe under the gas valve;
- **replace the gasket with a new one;**
- loosen the front cross head screw (4) of the black plastic silencer;
- after this turn the two clamping rods (9 and 10) ¼ turn and remove them by pulling them forward. **Note the correct turning direction (red indicator, fig. 13.3.e);**
- slightly lift the fan unit and remove it towards the front of the heat exchanger;
- remove the burner cassette out of the fan unit;
- check the burner cassette for wear, pollution and possible cracks. Clean the burner cassette with a soft brush and vacuum cleaner.

**If burners are cracked replace the complete burner cassette;**

- **replace the gaskets between burner and fan unit and the gasket between fan unit and heat exchanger;**
- check the venturi and the gas-air distribution plate for pollution and clean this part, if necessary with a soft brush and vacuum cleaner. If the air box contains a lot of dirt it is plausible that the fan itself is dirty as well. To clean this, the fan has to be removed from the hood and the venturi. Clean the fan with a soft brush and a vacuum cleaner. Replace the gasket and ensure that all gaskets of the fan parts are mounted correctly.

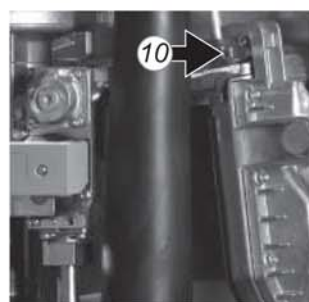

figure 13.3.d

### Heat exchanger

- check the heat exchanger for contamination. Clean this if necessary with a soft brush and a vacuum cleaner. Prevent dirt falling down into the heat exchanger.  
**Flushing the heat exchanger from the top down is not permitted**

Refitting of the components is done in reverse order.

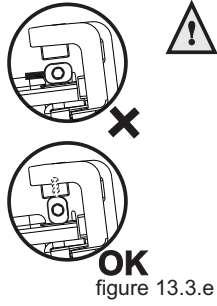

figure 13.3.e

**Make sure that during refitting of the clamping rods, they are put into the correct position. They should be turned vertically.**

Ignition electrode

The replacement of the electrode is only necessary when the electrode is worn off. This can be checked by measuring the ionisation current. The minimum ionisation current has to be higher than 4µA on full load.

If the viewing glass is damaged the complete electrode must be replaced.

Replacement goes as follows:

- remove the electrical connections of the electrode;
- press the clips on both sides of the electrode to both sides and remove the complete electrode;
- remove and replace the gasket;

Refitting of the components is done in reverse order.

Siphon and condensate tray (see fig. 13.3.f and g)

**Step 1: Siphon**

- first remove the condensate cup (7);
- Check this for pollution. If there is no sign of strong pollution it is not necessary to clean the condensate tray (Go to Step 3). If there is strong pollution in the cup it is necessary to remove and clean the condensate tray according to Step 2;
- remove the inner siphon pipe (8) which remains in the condensate tray;
- check the O-rings of the cup as well as those from the pipe and replace if necessary;
- clean both parts by flushing it with clean water;
- grease the O-rings again with acid free O-ring grease to make fitting easier;
- if there is a leak at the condensate cup (7) or tray (9) the complete condensate trap unit (10) has to be replaced by S4451610;

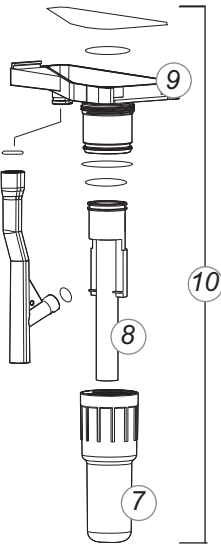

Siphon figure 13.3.f

**Step 2: Condensate tray**

- remove the plug from the flue gas sensor if present;
- turn the two short clamping rods (11 and 12) ¼ turn and remove them by pulling them forward; **Note the correct turning direction (red indicator, fig. 13.3.h);**
- lift the exhaust pipe (13) out of the condensate tray (14);
- press the condensate tray (14) carefully downwards and remove it by pulling it forward;
- replace the gasket between condensate tray and heat exchanger by a new one;
- clean the condensate tray with water and a hard brush;
- check the condensate tray on leaks.

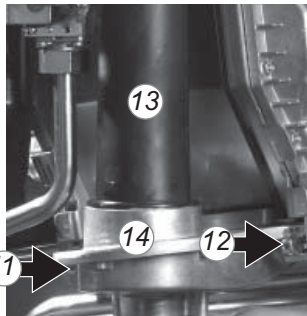

Condensate tray figure 13.3.g

**Step 3: Refitting is done in reverse order.**

Note that all gaskets seals completely.

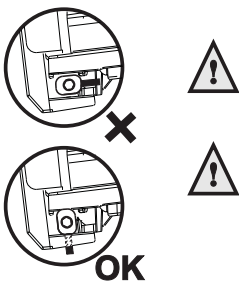

figure 13.3.h

**Make sure that during refitting the clamping rods they are put in the right position. They should be turned vertical.**

**Always replace all removed gaskets of dismantled parts during the maintenance activities.**

Put the boiler into operation and check the O<sub>2</sub> (see page 35).

#### Cylinder (when applicable)

The casing of the cylinder may be cleaned with a damp cloth and a little soap. Do not use any abrasive or solvent material which could damage the case or fittings.

The following maintenance work has to be carried out by the competent installer.

- Inspection of pressure/temperature relief valve and expansion relief valve. Manually operate each valve by twisting the operating cap, and check if water flows unobstructed via the tundish to the discharge point. ensure that both valves re-seat satisfactorily.
- Check pressure of expansion vessel.  
Turn off mains water supply and open nearest hot water tap to depressurise the secondary water system.  
Check the expansion vessel charge pressure gauge at the test point. If the pressure is below 3.0 bar, top up with suitable air pressure pump.
- Complete service section of cylinder commissioning checklist.



**In the event that parts require replacement, use only genuine parts supplied by STREBEL Ltd.**

Please contact your installer or STREBEL Ltd. for further details. Contact details can be found on the back page of this manual.

## 13.4 Draining the installation

During servicing one of the following items has to be drained:

#### Central heating system - boiler

*The central heating system and boiler can be drained using the fill- and drain valve installed in the system. If service valves are installed (advised) the boiler can be drained separately from the rest of the installation via the drain valves on the service valves.*

## 13.5 User's instructions

Hand these instructions and the user manual to the user for retention and instruct in the safe operation of the boiler and cylinder. Advise the user of the operation of the cylinder temperature, and that normally a setting of max. which gives a stored water temperature of approximately 60°C is adequate.



**In hard water areas the DHW temperature setting should not exceed this setting to avoid possible scale build-up.**

Frost protection

Advise the user of the precautions necessary to prevent damage to the system and to the building if the system does not remain operative during frost conditions.

Please ensure that if you are absent during a period of frost the central heating system remains in operation and the rooms and cylinder are kept above freezing point.

Finally, advise the user that for continued efficient and safe operation, the boiler and cylinder should be serviced at least once a year by a qualified servicing company. It is important and strongly recommended that arrangements are made for a maintenance agreement with a qualified servicing company to ensure regular servicing of the boiler and cylinder.

Please contact STREBEL Ltd. for further details. Contact details can be found on the back page of this manual.

## 13.6 Maintenance frequency

STREBEL Ltd. UK advises a service at least once a year, with a full strip down service depending on the operational hours.

## 13.7 Warranty

For the warranty conditions we refer to the Warranty Card that is supplied with the boiler.



## 14 Error indication

A detected error is indicated on the display by means of blocking or error messages. A distinction should be made between these two messages due to the fact that blocking can be of a temporary nature, however, error messages are fixed lockings. The control will try its utmost to prevent locking and will temporarily switch off the unit by blocking it. Hereunder is a list of some messages.

Blocks **bL** with a number in the last 2 positions.

- bL01** Block 01:  
External safety contact cut off
- bL11** Block 11:  
Maximum  $\Delta T$  of flow and return sensor in central heating has repeatedly been exceeded. During the block normal operation of the hot water supply is possible. The pump continues to operate at minimum capacity during the block.
- bL12** Block 12:  
Maximum  $\Delta T$  of flow and return sensor in domestic hot water has repeatedly been exceeded. During the block normal operation of the central heating installation is possible. During the block the pump continues to operate at minimum capacity.
- bL60** Block 60:  
Incorrect parameter setting of the minimum or maximum power.
- bL67** Block 67:  
A  $\Delta T$  has been detected between flow and return sensor whereas the burner is not in operation. After the  $\Delta T$  has disappeared the block will disappear.
- bL80** Block 80:  
Maximum flow temperature T1a has been exceeded (only Q60S). The block will not be cancelled until the flow temperature has decreased 30K.
- bL81** Block 81:  
The flow sensor T1a (only Q60S) is not connected although it was connected to the control. The burner is blocked until the flow sensor is reconnected.
- bL82** Block 82:  
The flow sensor has short-circuited (only Q60S), heat requirement blocked and pump capacity at minimum.
- bL85** Block 85:  
The control has not detected a water flow. The venting cycle is started. If during this cycle water flow is detected, the venting cycle is ended and the burner is released.

Error **E** with a number in the last two positions.

- E 00** Error 00: Poor flame-forming
- E 02** Error 02: no flame-forming. Boiler failed to spark, lite or detect a flame picture.
- E 04** Error 04: adjustment or error for voltage interruption
- E 05** Error 05: adjustment fault
- E 18** Error 18: maximum flow temperature exceeded
- E 19** Error 19: maximum return temperature exceeded
- E 28** Error 28: number of revolutions not reported back from fan
- E 69** Error 69: no or incorrect display
- E 80** Error 80: maximum flue gas sensor temperature exceeded
- FUSE** FUSE: Fuse 24V circuit defective

## Annex A Technical specifications

Boiler type		STREBEL S-HQ Serie						
		Q25C	Combi Q38C	Q51C	Q25S	Solo Q38S	Q51S	Q60S
Input Hs CH	kW	25	38	51	25	38	51	60
Q <sub>n</sub> Input Hi CH	kW	22,5	34,2	45,9	22,5	34,2	45,9	54
Q <sub>nw</sub> Input Hi DHW		31,5						
Efficiency class according BED		★★★★	★★★★	★★★★	★★★★	★★★★	★★★★	★★★★
Efficiency according EN677 (36/30°C part load, Hi)	%	109,7	109,1	109,3	109,7	109,1	109,3	109,3
Efficiency according EN677 (80/60°C full load, Hi)	%	97,5	97,4	97,3	97,5	97,4	97,3	97,3
Modulation range CH (capacity 80/60°C)	kW	6.0 - 21.9	6.0 - 33.3	8.8 - 44.7	4.4 - 21.9	6.0 - 33.3	8.8 - 44.7	8.8 - 52.5
Modulation range CH (capacity 50/30°C)	kW	6.8 - 23.9	6.8 - 36.3	9.8 - 48.7	4.9 - 23.9	6.8 - 36.3	9.8 - 48.7	9.8 - 57.3
Nox class EN483		5						
CO <sub>2</sub>	%	9						
Flue gas temp. CH (80/60°C on full load)	°C	68	69	70	68	69	70	70
Flue gas temp. CH (50/30°C on low load)	°C	31						
Gas consumption G20 CH (DHW) (at 1013 mbar/15°C)	m <sup>3</sup> /h	2,38 (3,33)	3,62	4,86	2,38	3,62	4,86	5,71
Electr. power consumption max.	W	106	165	150	106	165	150	168
Electr. power consumption stand by	W	10						
Current	V/Hz	230/50						
Degree of protection acc. EN 60529		IPX0D						
Weight (empty)	kg	79	79	89	50	53	64	64
Width	mm	840	840	1000	500	500	660	660
Height	mm	680						
Depth	mm	385						
Water content CH	l	5	5	7	3,5	5	7	7
Water content DHW	l	14	14	14				
After run time pump CH	min	5						
After run time pump DHW	min	1	1	1				
P <sub>MS</sub> Water pressure min./max.	bar	1/3						
P <sub>MW</sub> Water pressure DHW max.	bar	8						
Flow temperature max.	°C	85						
Pump type	UPER	20-60	20-70	20-70	20-60	20-70	20-70	20-70
Available pump height CH	kPa	29	20		32	22		
DHW flow (at 38°C)	l/min	13,4	16,6	23,2				
DHW flow (at 60°C)	l/min	7,5	9,3	13				
DHW temperature (T <sub>in</sub> =10°C)	°C	60	60	60				
CE product identification number(PIN)		0063BQ3021						

## Annex B System water additives

When the filling water requirements as referred to in chapter Water Quality have been met, certain additives are allowed for the below mentioned applications and related dosage. Warranty on STREBEL delivered installation products expires, if these additives and concentrations are not used in accordance with this annex.

Additive type	Supplier and specifications	Max. concentration	Application
Corrosion inhibitors	Sentinel X100 Corrosion resistant protection agent of CH systems Kiwa certified	1-2 l/100 litres CH water content	Aqueous solution of organic and inorganic agents preventing corrosion and scale forming
Anti-freeze	Kalsbeek Monopropyleneglycol / propane-1,2-diol + inhibitors AKWA-Colpro KIWA-ATA Nr. 2104/1	50% w/w	Anti-freeze
	Tyfocor L Monopropyleneglycol / propane-1,2-diol + inhibitors	50% w/w	Anti-freeze
	Sentinel X500 Monopropyleneglycol + inhibitors Kiwa certified	20-50% w/w	Anti-freeze
System cleaners	Sentinel X300 Solution of phosphate, organic heterocyclic compounds, polymers and organic bases Kiwa certified	1 litre / 100 litres	For new CH installations Removes oils/grease and flow control agents
	Sentinel X400 Solution of synthetic organic polymers	1-2 litres / 100 litres	For cleaning existing CH-installations Removes sediments.
	Sentinel X800 Jetflo Aqueous emulsion of dispersants, moistening agents and inhibitors	1-2 litres / 100 litres	For cleaning new and existing CH-installations Removes iron and lime-related sediments.

# Annex C Dimensions

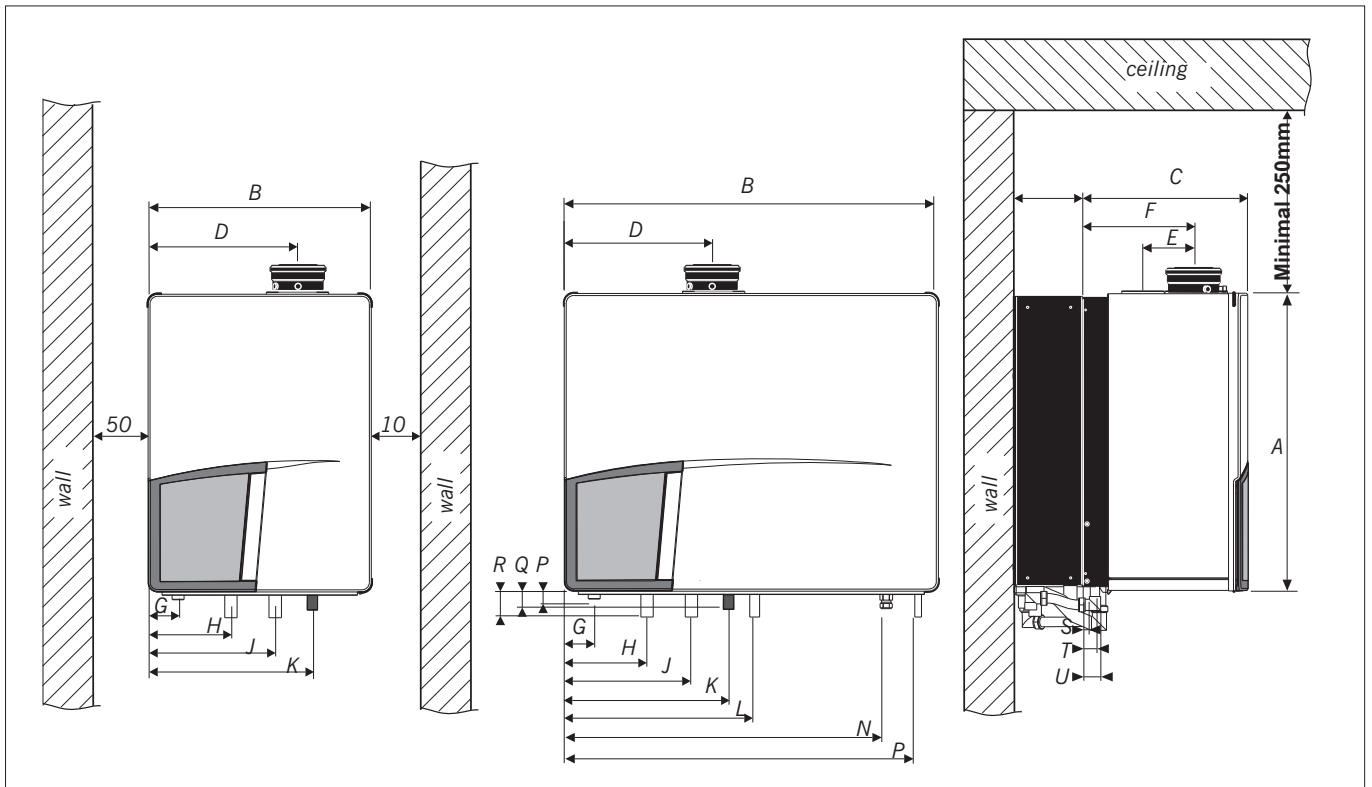

Boiler type		STREBEL S-HQ Serie							
		Q25C	Q38C	Q51C	Q25S	Q38S	Q51S	Q60S	
A	Height	mm	680	680	680	680	680	680	680
B	Width	mm	840	840	1000	500	500	660	660
C	Depth	mm	385	385	385	385	385	385	385
D	Left side / flue gas connexion	mm	335	335	495	335	335	495	495
E	Centre to centre flue gas and air supply	mm	120	120	120	120	120	120	120
F	Back / flue gas connexion	mm	270	270	270	270	270	270	270
G	Left side / gas pipe	mm	65	65	65	65	65	65	65
H	Left side / flow pipe	mm	185	185	185	185	185	185	185
J	Left side / return pipe	mm	285	285	445	285	285	445	445
K	Left side / condensate pipe	mm	370	370	530	370	370	530	530
L	Left side / expansion pipe	mm	430	430	590				
M	Left side / return pipe DHW								
N	Left side / cold water pipe	mm	725	725	885				
O	Left side / hot water pipe		765	795	955				
P	Pipe length of g*	mm	18	18	18	18	18	18	18
Q	Pipe length of c*	mm	40	40	40	40	40	40	40
R	Pipe length of a; r*	mm	60	60	60	60	60	60	60
S	Back / centre of pipe c*	mm	25	25	25	25	25	25	25
T	Back / centre of pipe g*	mm	40	40	40	40	40	40	40
U	Back / centre of pipe a and r*	mm	50	50	50	50	50	50	50

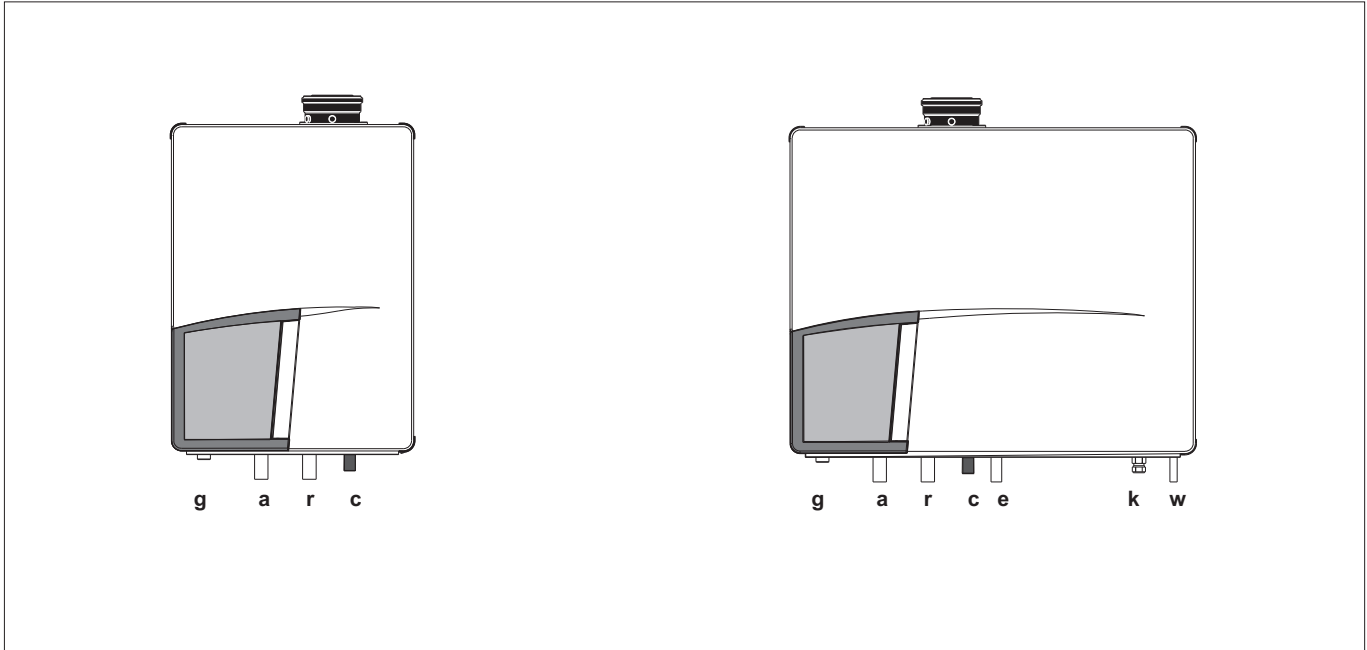

		STREBEL S-HQ Serie						
Boiler type		Q25C	Q38C	Q51C	Q25S	Q38S	Q51S	Q60S
	Concentric flue system	mm	80/125	80/125	80/125	80/125	80/125	80/125
	Parallel flue system	mm	optional	optional	optional	optional	optional	optional
g	Gas pipe		3/4"Rp	3/4"Rp	1/2"Rp	3/4"Rp	3/4"Rp	1/2"Rp
a	Flow pipe	mm	28	28	35	28	28	35
r	Return pipe	mm	28	28	35	28	28	35
c	Condensate pipe	mm	24	24	24	24	24	24
e	Expansion pipe	mm	22	22	22			
k	Cold water pipe	mm	15	15	15			
h	Hot water pipe	mm	15	15	15			
d	Return pip DHW	mm						

## D.1 Radiator installation without thermostatic radiator valves

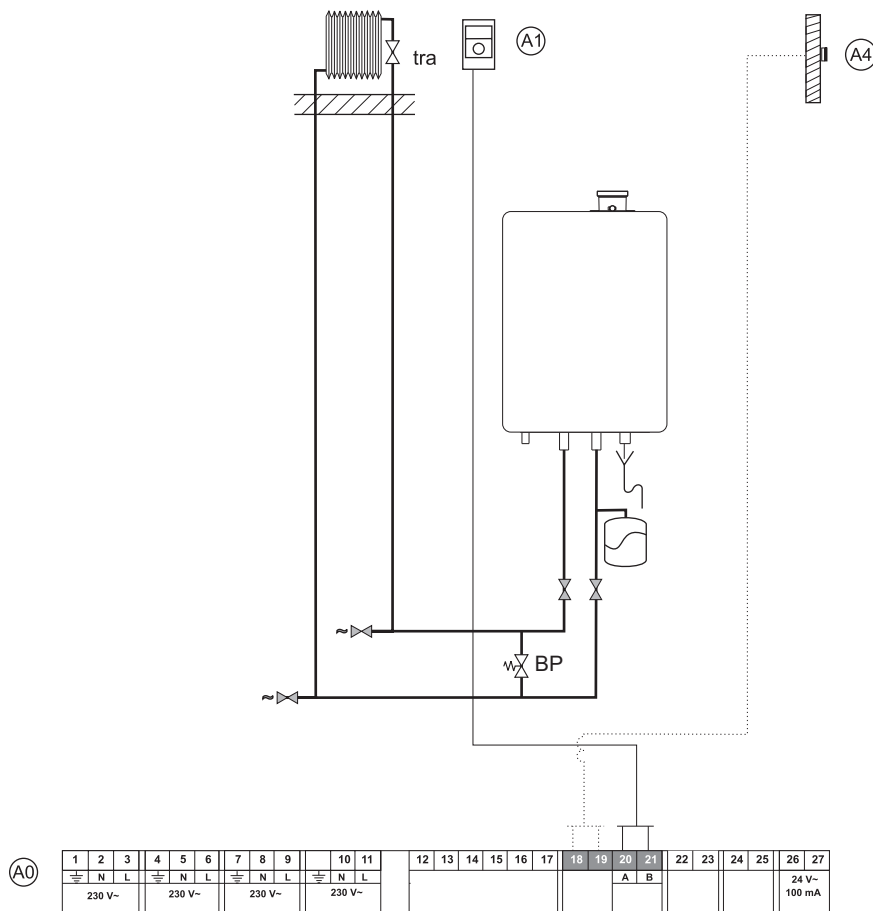

- A Boiler:**
- A0 Connection terminal STREBEL S-HQ
  - A1 BrainQ thermostat RSC
  - A4 Outside sensor ARV12
  - tra Thermostatic radiator valve
  - BP Automatic by-pass



**Use always a by pass in combination with thermostatic radiator valves. Low loss header required for Q51 and Q60.**

## D.2 Radiator installation with underfloor heating zone

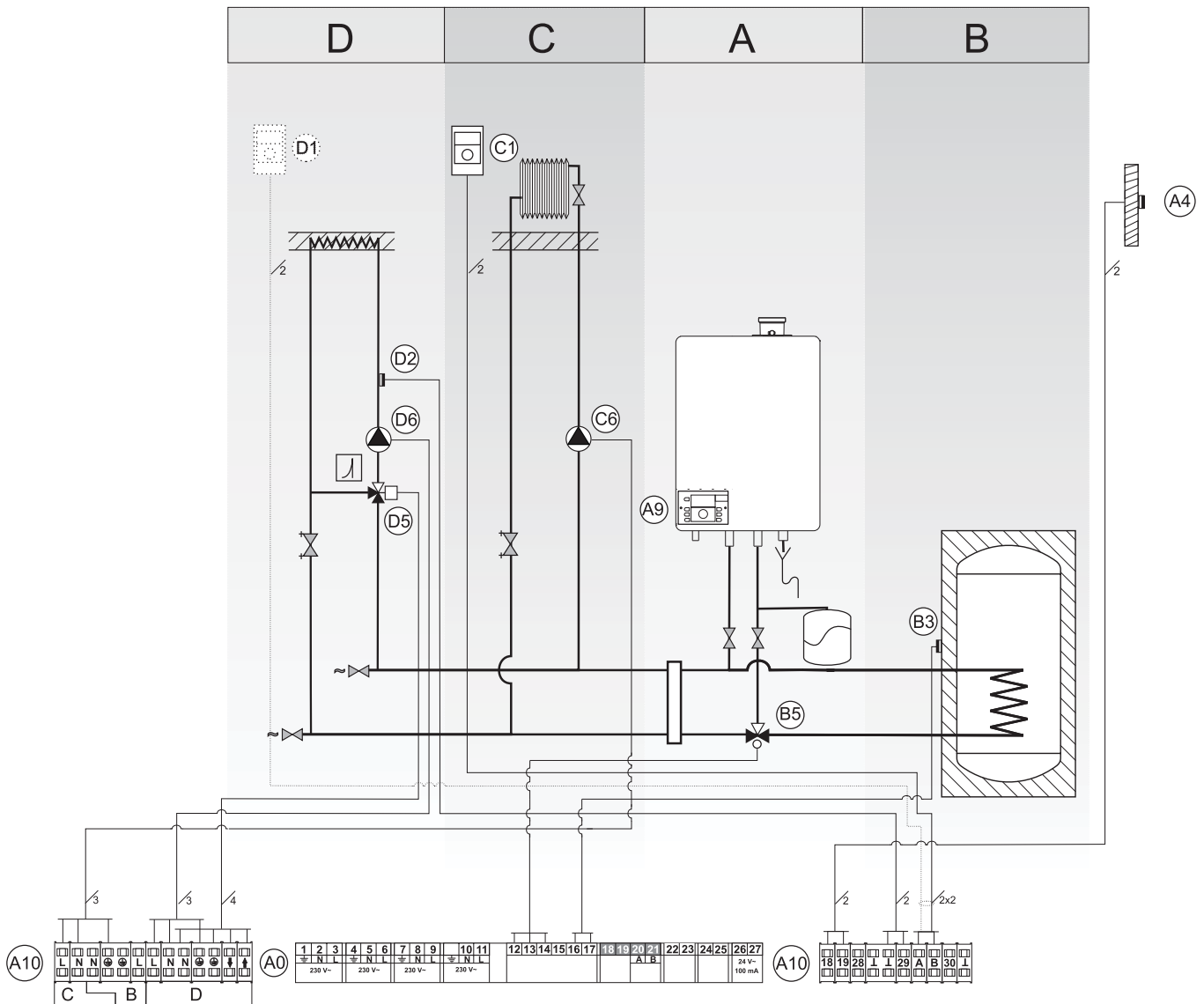

### A Boiler:

- A0 Connection terminal STREBEL S-HQ
- A4 Outside sensor ARV12
- A9 MadQ zone controller 23BC
- A10 Connection terminal MadQ built in

### B Cylinder:

- B3 Cylinder sensor
- B5 Three-way valve cylinder

### C Direct zone:

- C6 Pump direct zone

### D Mixing zone:

- D2 Flow sensor mixing zone
- D5 Three way valve mixing zone 230V~
- D6 Pump mixing zone

See also the installation manual MadQ Zone controller.

**CE DECLARATION OF CONFORMITY**

Hereby declares ATAG Verwarming Nederland BV that,

the condensing boiler types: ATAG

Q25S	Q25C
Q38S	Q38C
Q51S	Q51C
Q60S	

are in conformity with the provisions of the following EC Directives, including all amendments, and with national legislation implementing these directives:

<u>Directive</u>		<u>Used standards</u>
Gas Appliance Directive	2009/142/EC (ex.90/396/EEG)	EN483: 1999,A2 ;2001-C1 ;2006,A4 ;2007 EN50165: 1997
Efficiency Directive	92/42/EEC	EN677: 1998
Low Voltage Directive	2006/95/EG	EN50165: 1997 EN60335-1: 1994
EMC Directive	2004/108//EG	EN61000-3-2: 2000,A1 ;2001,A2 ;2005 EN61000-3-3: 1995,2006 EN55014-1: 1993,A1;2001,A2;2002 EN50165: 1997,A1;2001 EN55014-2: 1997,A1;2001

Report numbers

	GAD	ED	LVD	EMC D
ATAG Q	177021	177021	177021	178195-EMC

and that the products are in conformity with EC type-examination certificate number E0430, as stated by KIWA-Gastec Certification BV, Apeldoorn, The Netherlands.

Date : 2-11-2010

Signature :



Full name : C. Berlo  
CEO



Adres: Galileistraat 27, 7131 PE Lichtenvoorde • Postadres: Postbus 105, 7130 AC Lichtenvoorde  
Telefoon: +31(0) 544 391777, Fax: +31(0) 544 391703  
E-mail: info@atagverwarming.com Internet: http://www.atagverwarming.nl



Certificate



**UK APPROVAL**  
**Certificate Number: 0911703**

Date Issued: 30<sup>th</sup> November 2009  
Date Expired: 12<sup>th</sup> November 2014

**Description: 'Q' Range of wall mounted sealed circuit and combination boilers.**

Product Designation:  
**Q25S, Q38S, Q51S, Q60S, Q25C Q38C and Q51C**

This is to certify that the above range of products manufactured / supplied by

**ATAG VERWARMING NEDERLAND BV**

1. Has been tested and found to comply with the requirements of the Water Supply (Water Fittings) Regulations 1999 for England and Wales, the Water Byelaws 2000, Scotland and the Water Regulations Northern Ireland.

This certificate must be read in conjunction with the acceptance letter for this product.

*This approval is intended for compliance with the above Regulations and must not be considered equivalent to the product certification provided by Kiwa N.V*

To comply with the Regulations and Byelaws all products require the correct installation. Details of the installation requirements (IRN's) can be obtained from the acceptance letter supplied with this certificate.  
Applicable IRN's for this certificate – R001, R140, R360

Authorised Signature  
Kiwa Quality Services Ltd

Kiwa Quality Services Ltd  
The Innovation Centre  
Victoria Park  
Festival Drive  
Ebbw Vale  
Gwent  
NP23 8XA

Tel 00 44 (0) 1495 356795  
Fax 00 44 (0) 1495 350020  
E-mail: [info@kiwa.co.uk](mailto:info@kiwa.co.uk)  
Web: [www.kiwa.co](http://www.kiwa.co)

Certificate Issued To –

**ATAG VERWARMING NEDERLAND BV**  
Gallileistraat 27  
7131PE Lichtenvoorde  
Netherlands





# Service Record

It is recommended that your heating system is serviced regularly and that the appropriate Service Interval Record is completed.

## Service Provider

Before completing the appropriate Service Record below, please ensure you have carried out the service as described in the manufacturer's instructions.

Always use the manufacturer's specified spare part when replacing controls.

### Service 1

Date: \_\_\_\_\_

Engineer Name: \_\_\_\_\_

Company Name: \_\_\_\_\_

Telephone No. \_\_\_\_\_

Gas Safe Register No. \_\_\_\_\_

Comments: \_\_\_\_\_  
\_\_\_\_\_  
\_\_\_\_\_

Signature: \_\_\_\_\_

### Service 2

Date: \_\_\_\_\_

Engineer Name: \_\_\_\_\_

Company Name: \_\_\_\_\_

Telephone No. \_\_\_\_\_

Gas Safe Register No. \_\_\_\_\_

Comments: \_\_\_\_\_  
\_\_\_\_\_  
\_\_\_\_\_

Signature: \_\_\_\_\_

### Service 3

Date: \_\_\_\_\_

Engineer Name: \_\_\_\_\_

Company Name: \_\_\_\_\_

Telephone No. \_\_\_\_\_

Gas Safe Register No. \_\_\_\_\_

Comments: \_\_\_\_\_  
\_\_\_\_\_  
\_\_\_\_\_

Signature: \_\_\_\_\_

### Service 4

Date: \_\_\_\_\_

Engineer Name: \_\_\_\_\_

Company Name: \_\_\_\_\_

Telephone No. \_\_\_\_\_

Gas Safe Register No. \_\_\_\_\_

Comments: \_\_\_\_\_  
\_\_\_\_\_  
\_\_\_\_\_

Signature: \_\_\_\_\_

### Service 5

Date: \_\_\_\_\_

Engineer Name: \_\_\_\_\_

Company Name: \_\_\_\_\_

Telephone No. \_\_\_\_\_

Gas Safe Register No. \_\_\_\_\_

Comments: \_\_\_\_\_  
\_\_\_\_\_  
\_\_\_\_\_

Signature: \_\_\_\_\_

### Service 6

Date: \_\_\_\_\_

Engineer Name: \_\_\_\_\_

Company Name: \_\_\_\_\_

Telephone No. \_\_\_\_\_

Operative ID No. \_\_\_\_\_

Comments: \_\_\_\_\_  
\_\_\_\_\_  
\_\_\_\_\_

Signature: \_\_\_\_\_

### Service 7

Date: \_\_\_\_\_

Engineer Name: \_\_\_\_\_

Company Name: \_\_\_\_\_

Telephone No. \_\_\_\_\_

Gas Safe Register No. \_\_\_\_\_

Comments: \_\_\_\_\_  
\_\_\_\_\_  
\_\_\_\_\_

Signature: \_\_\_\_\_

### Service 8

Date: \_\_\_\_\_

Engineer Name: \_\_\_\_\_

Company Name: \_\_\_\_\_

Telephone No. \_\_\_\_\_

Gas Safe Register No. \_\_\_\_\_

Comments: \_\_\_\_\_  
\_\_\_\_\_  
\_\_\_\_\_

Signature: \_\_\_\_\_

### Service 9

Date: \_\_\_\_\_

Engineer Name: \_\_\_\_\_

Company Name: \_\_\_\_\_

Telephone No. \_\_\_\_\_

Gas Safe Register No. \_\_\_\_\_

Comments: \_\_\_\_\_  
\_\_\_\_\_  
\_\_\_\_\_

Signature: \_\_\_\_\_

### Service 10

Date: \_\_\_\_\_

Engineer Name: \_\_\_\_\_

Company Name: \_\_\_\_\_

Telephone No. \_\_\_\_\_

Gas Safe Register No. \_\_\_\_\_

Comments: \_\_\_\_\_  
\_\_\_\_\_  
\_\_\_\_\_

Signature: \_\_\_\_\_

# STREBEL

STREBEL LTD. • 1F, Albany park industrial estate • Frimley road, Camberley • Surrey GU15 2PL  
Telephone: (01276) 685422 • Fax: (01276) 685405 • E-mail: [info@strebel.co.uk](mailto:info@strebel.co.uk) • Internet: [www.strebel.co.uk](http://www.strebel.co.uk)

E. & O. M.

This renewed publication cancels all previous installation instructions. The company reserves the right to change the specifications and dimensions without prior notice.