

STARFIRE 3 WATER

OIL FIRED CAST IRON BOILER

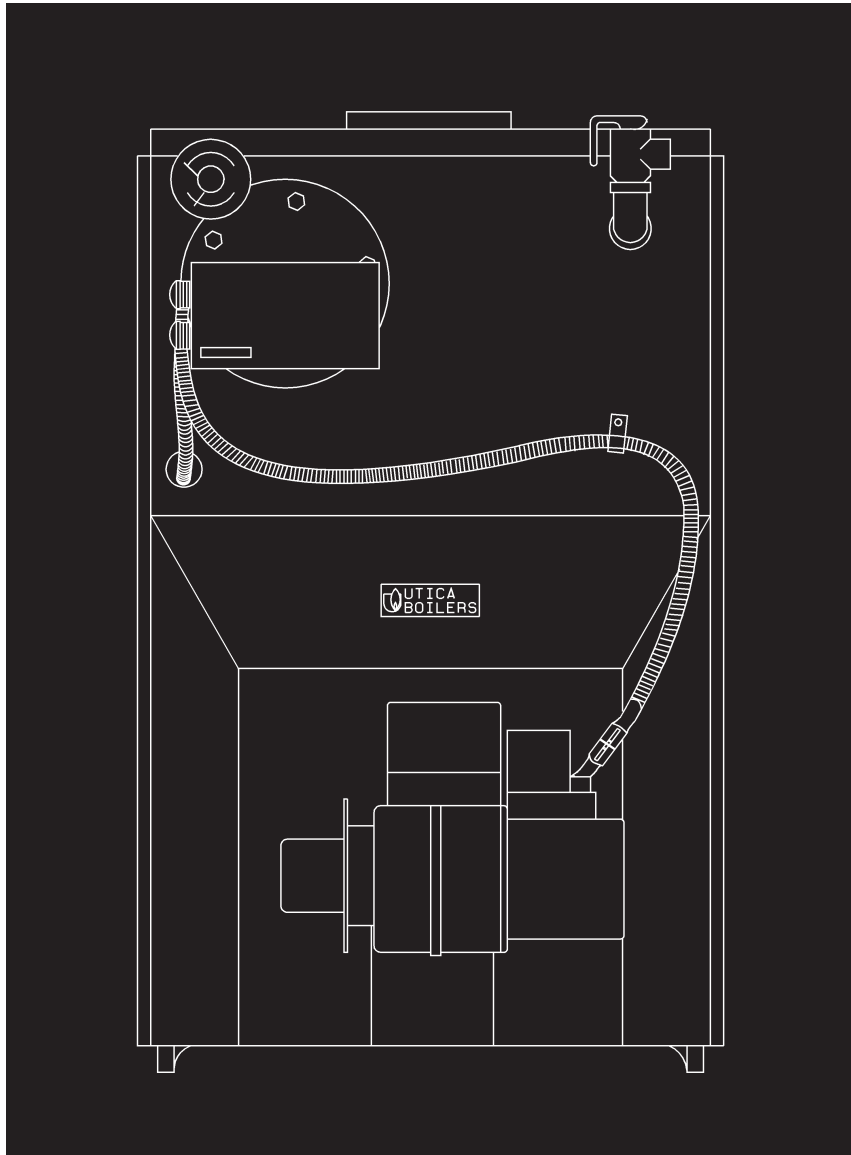

Utica Boilers • P.O. Box 4729 • Utica, NY 13504

INSTALLATION MANUAL AND OPERATING INSTRUCTIONS

TABLE OF CONTENTS

SAFETY SYMBOLS & WARNINGS	PAGE 1
INSTALLATION PROCEDURE	PAGE 2
VENTILATION AND COMBUSTION AIR	PAGES 3-5
CONNECTING SUPPLY AND RETURN PIPING	PAGES 6-9
TANKLESS HEATER PIPING	PAGE 10
3/4" TAPPING OPTIONS	PAGE 11
VENTING SYSTEM INSPECTION & INSTALLATION	PAGE 12
OIL TANK PIPING	PAGE 13
ELECTRICAL WIRING	PAGES 14
THERMOSTAT INSTALLATION	PAGE 15
NORMAL SEQUENCE OF OPERATION	PAGE 15
OPERATING INSTRUCTIONS	PAGES 16-19
SERVICE CHECK LIST	PAGE 20
REPLACEMENT PARTS LIST	PAGES 21-28
RATINGS, DATA AND DIMENSIONS	PAGE 29-30

KEEP THIS MANUAL NEAR BOILER. RETAIN FOR FUTURE REFERENCE

SERIES SFH 3
CAST IRON
OIL FIRED BOILER

INSTALLATION MANUAL AND OPERATING INSTRUCTIONS

PUBLISHED FEBRUARY 1996
PRINTED IN USA
MADE IN USA



TESTED FOR 100 LBS.
ASME WORKING PRESSURE

Safety Symbols

The following defined symbols are used throughout this manual to notify the reader of potential hazards of varying risk levels.

DANGER

DANGER - Indicates an imminently hazardous situation which, if not avoided, WILL result in death or serious injury.

WARNING

WARNING - Indicates a potentially hazardous situation which, if not avoided, COULD result in death or serious injury

CAUTION

CAUTION - Indicates a potential hazardous situation which, if not avoided, MAY result in minor or moderate injury. It may also be used to alert against unsafe practices.

IMPORTANT! READ ALL INSTRUCTIONS BEFORE INSTALLING.

WARNING:

1. Keep boiler area clear and free from combustible materials, gasoline and other flammable vapors and liquids.
2. **DO NOT** obstruct air openings to the boiler room.
3. Modification, substitution or elimination of factory equipped, supplied or specified components may result in property damage, personal injury or the loss of life.
4. To the owner: Installation and service of this boiler must be performed by a qualified installer.
5. To the installer: Leave all instructions with the boiler for future reference.
6. When this product is installed in the Commonwealth of Massachusetts, the installation must be performed by a licensed Plumber or Licensed Gas Fitter.

 **WARNING:** **ALL INSTALLATIONS OF BOILERS AND VENTING SHOULD BE DONE ONLY BY A QUALIFIED EXPERT AND IN ACCORDANCE WITH THE APPROPRIATE UTICA BOILERS MANUAL. INSTALLING OR VENTING A BOILER OR ANY OTHER GAS APPLIANCE WITH IMPROPER METHODS OR MATERIALS MAY RESULT IN SERIOUS INJURY OR DEATH DUE TO FIRE OR TO ASPHYXIATION FROM POISONOUS GASES SUCH AS CARBON MONOXIDE WHICH IS ODORLESS AND INVISIBLE.**

INSTALLATION PROCEDURE



WARNING:

Improper installation, adjustment, alteration, service or maintenance can cause property damage, personal injury or loss of life.

All installations must conform to the requirements of the authority having jurisdiction. Such applicable requirements take precedence over the general instructions of this manual.

Where required by the authority having jurisdiction, the installation must conform to the American Society of Mechanical Engineers Safety Code for Controls and Safety Devices for Automatically Fired Boilers, ANSI/ASME No. CSD-1. In Canada all installations must be in accordance with the authorities having jurisdiction and CSA B139.

LOCATE BOILER in front of final position before removing crate. Provide a level solid base as near chimney as possible and centrally located with respect to the heat distribution system as practical.



WARNING:

BOILER MAY NOT BE INSTALLED ON COMBUSTIBLE FLOORING.

Allow 24 inches in the front and top for servicing and cleaning, or removing tankless water heating coil.

When installed in a utility room, the door should be wide enough to allow the largest boiler part to enter, or to permit replacement of another appliance such as a water heater.

FOR INSTALLATION ON NON-COMBUSTIBLE FLOORS ONLY. The boiler must not be installed on carpeting or vinyl flooring. Minimum clearances to combustible construction are:

TOP	24 IN.
FRONT	24 IN.
FLUE CONNECTOR.....	9 IN.
REAR	6 IN.
SIDES	6 IN.

NOTE: CLEARANCE FOR ACCESS SHOULD EXCEED FIRE PROTECTION CLEARANCE.

REMOVE CRATE and plastic protective wrapper and inspect for damage. All equipment is carefully manufactured, inspected and packaged by experienced workers. Our responsibility ceases upon delivery of the crated boiler to the carrier in good condition. Any claims for damage or shortage in shipment must be filed immediately against the carrier by the consignee. Move boiler to permanent position by sliding or walking.

VENTILATION & COMBUSTION AIR



WARNING: AIR OPENINGS TO COMBUSTION AREA MUST NOT BE OBSTRUCTED. BY FOLLOWING THE CHART BELOW, ADEQUATE COMBUSTION AIR CAN BE MAINTAINED.

COMBUSTION AIR REQUIREMENTS (Minimum Opening Requirements)				
	*UNCONFINED AREA		**CONFINED AREA	
	Outside	Inside	Outside Combustion Air	
BTU/HR INPUT	Combustion Air 1 IN. ² /5000 BTU/HR (Paragraph 4)	Combustion Air 1 IN. ² /1000 BTU/HR (See Fig 1) (MIN. 100 IN ²)	VERT. DUCTS 1 IN. ² /4000 BTU/HR (See Fig 2 & 3 Pages 5 & 6)	HORZ. DUCTS 1 IN. ² /2000 BTU/HR (See Fig 4 Page 6)
91,000	19	100	23	46
140,000	28	140	35	70
175,000	35	175	44	88
210,000	42	210	53	106
245,000	49	245	61	122
280,000	56	280	61	140

*Unconfined area: A space whose volume is not less than 50 cubic feet per 1000 BTU per hour of all appliances installed in that space (cubic feet of space = height x width x length).

**Confined area: A space whose volume is less than 50 cubic feet per 1000 BTU per hour of all appliances installed in that space (cubic feet of space = height x width x length).

1. Ventilation of boiler room must be adequate enough to provide sufficient air to properly support combustion.

2. When a boiler is located in an unconfined space in a building of conventional construction frame, masonry or metal, infiltration normally is adequate to provide air for combustion and ventilation. However, in any building which has been altered to conserve energy or to minimize infiltration, the boiler area should be considered as a CONFINED SPACE. If there is any doubt, install air supply provisions for combustion and ventilation in accordance with section 5.3, Air for Combustion and Ventilation, of the NFPA 54 1988 code, the recommendations that follow, or applicable provisions of the local building codes.

3. When a boiler is installed in an unconfined space, in a building of unusually tight construction, air for combustion and room ventilation must be obtained from outdoors or from spaces freely communicating with the outdoors. A permanent opening or openings

having a total free area of not less than 1 square inch per 5,000 BTU per hour of total input rating of all appliances shall be provided. Ducts may be used to convey make-up air from the outdoors and shall have the same cross-sectional area of the openings to which they are connected.

4. When air for combustion and room ventilation is from inside buildings, the confined space shall be provided with two permanent openings, one starting 12 inches from the top and one 12 inches from the bottom of the enclosed space. Each opening shall have a minimum free area of 1 square inch per one thousand (1,000) BTU per hour of the total input rating of all appliances in the enclosed space, but must not be less than one hundred (100) square inches. These openings must freely communicate with the interior areas having adequate infiltration from the outside. See figure 1 below.

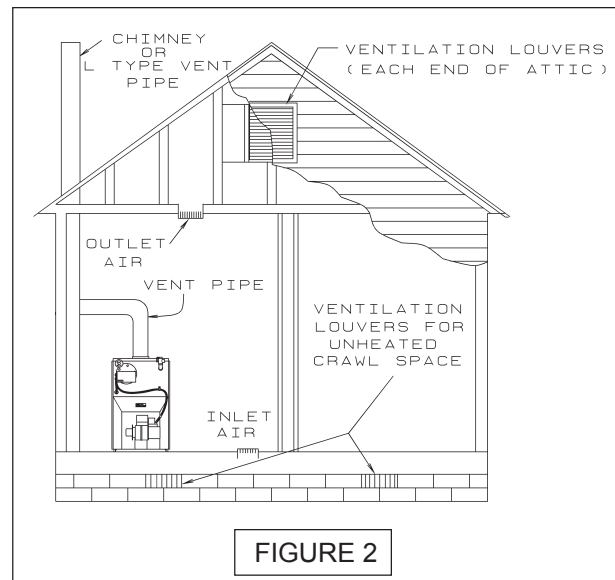
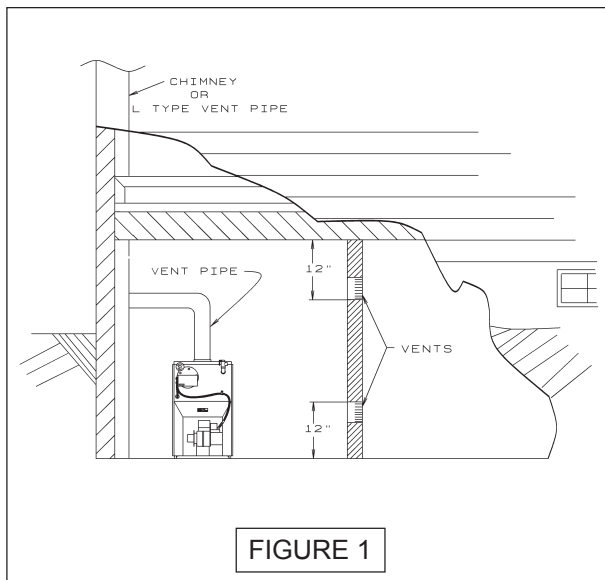

5. When the boiler is installed in a confined space and all air is provided from the outdoors, the confined space shall be provided with two permanent openings, one commencing within 12 inches from the top and one commencing 12 inches from the bottom of the enclosure. The openings shall communicate directly, or by ducts, with the outdoors or spaces (crawl or attic) that freely communicate with the outdoors. One of the following methods must be used to provide adequate air for ventilation and combustion.

A. When directly communicating with the outdoors, each opening shall have a minimum free area of 1 square inch per 4,000 BTU per hour of total input rating of all equipment in the enclosure. See figure 2, above.

B. When communicating with the outdoors by means of vertical ducts, each opening shall have a minimum free area 1 square inch per 4,000 BTU per hour of total input rating of all appliances in the enclosed space. See figure 3 on page 5.

C. If horizontal ducts are used, each opening shall have a minimum free area 1 square inch per 2,000 BTU per hour total input rating of all appliances in the enclosed space. See figure 4, on page 5.

D. When ducts are used, they shall be of the same cross sectional area as the free area of the area of the openings to which they connect. The minimum dimension of rectangular

air ducts shall not be less than 3 inches.

6. In calculating free area using louvers, grills or screens for the above, consideration shall be given to their blocking effect. Screens used shall not be smaller than 1/4 inch mesh. If the free area through a design of louver or grill is known, it should be used in calculating the size opening required to provide the free area specified. If the design and free area is not known, it may be assumed that wood louvers will have 20-25% free area and metal louvers and grills will have 60-75% free area. Louvers and grills shall be fixed in the open position or interlocked with the boiler so that they are opened automatically during boiler operation. See chart on page 4 for combustion air minimum opening requirements.

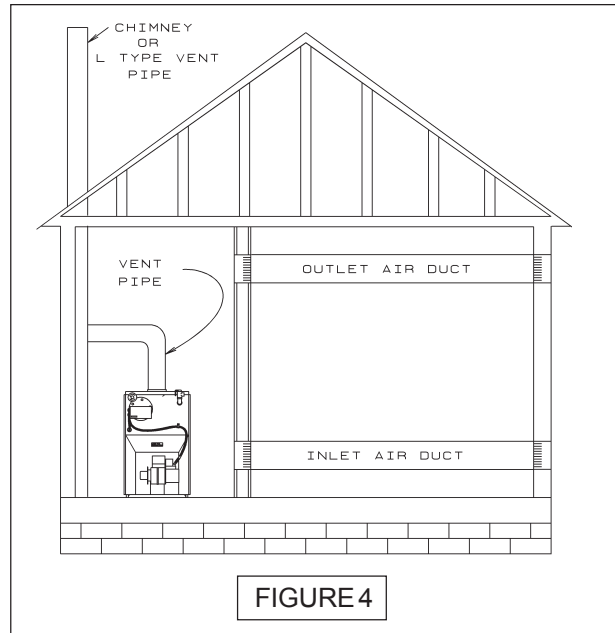
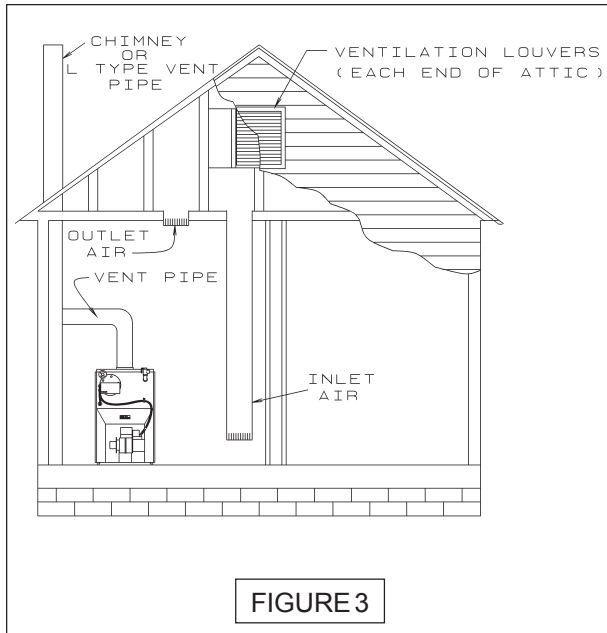

CONNECTING SUPPLY AND RETURN PIPING

IMPORTANT: Circulators in the following illustrations are mounted on the system supply side, but mounting on the system return side is also acceptable practice.

1. Connect supply and return piping as suggested in figure 5, below. When the boiler is used in connection with refrigerated systems:

- A. The chilled medium **MUST BE IN PARALLEL** with the boiler.
- B. Use appropriate valves to prevent the chilled medium from entering the heating boiler.

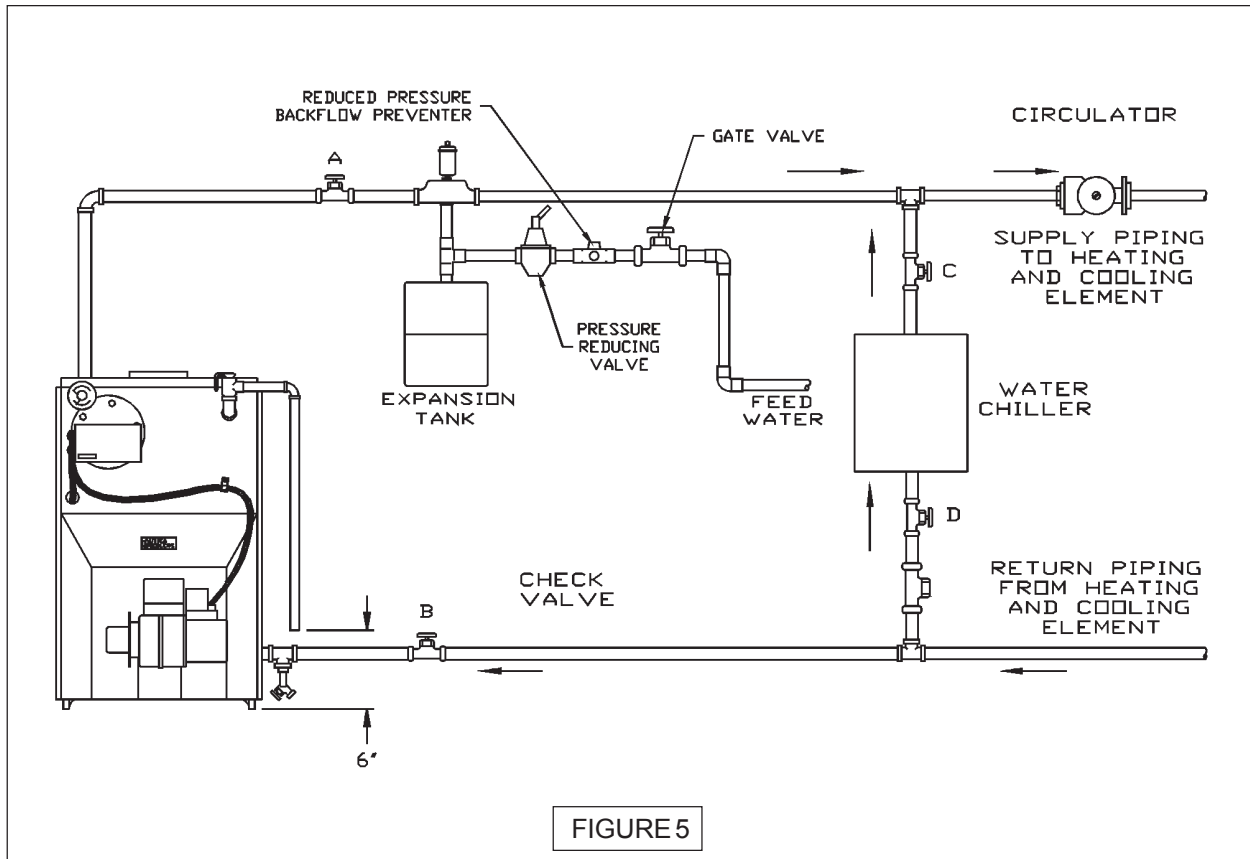

2. During the heating cycle open valves A and B, close valves C and D.

3. During heating cooling cycle open valves C and D, close valves A and B.

A. Maintain a minimum clearance of one inch to hot water pipes.

In air handling units where they may be exposed to refrigerated air circulation, the boiler piping system **MUST** be supplied with flow control valves or other automatic means to prevent gravity circulation of the boiler water during the cooling cycle.

4. Hot water boilers installed above radiation level must be provided with a low water device either as part of the boiler or at the time of boiler installation.

5. When a boiler is connected to a heating system that utilizes multiple zoned circulators, each circulator must be supplied with a flow control valve to prevent gravity circulation.

* Reduced pressure back flow preventer must be used under provisions required by the Environmental Protection Agency, (EPA).

6. Bypass piping is an option which gives the ability to adjust the supply boiler water temperature to fit the system or condition of the installation. Although, this method of piping is not typically required for baseboard heating systems.

A. This method is used to protect boilers from condensate forming due to low temperature return water. Generally noticed in large converted gravity systems or other large water volume systems. See figure 6 below.

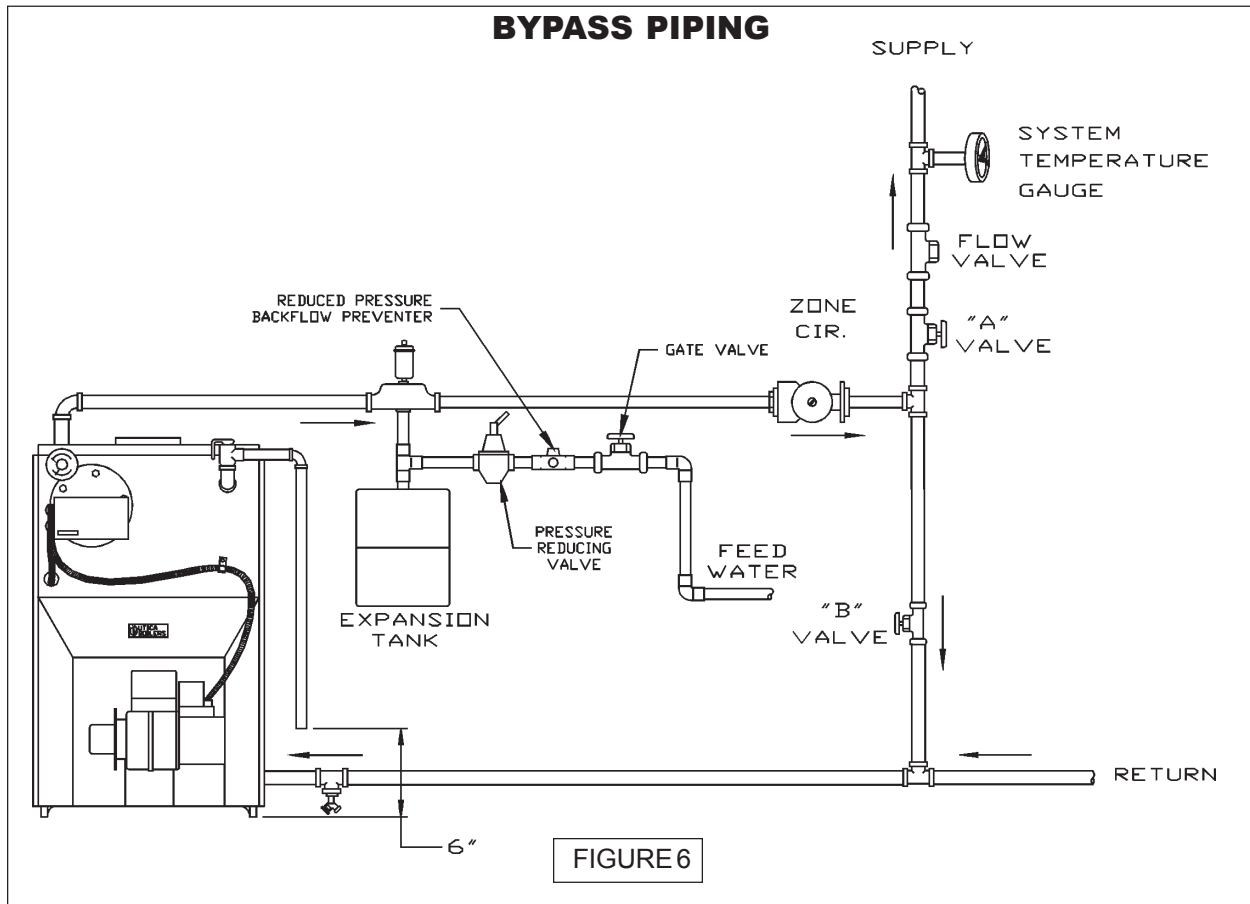

B. These methods are used to protect systems using radiant panels and the material they are encased in from high temperature supply water from the boiler and protect the boiler from condensation. See figures 7 and 8 on page 8.

C. This method is used to protect boilers from condensate forming as well as protecting the heating system from high water temperature. See figure 8 on page 8.

7. Note: When using bypass piping, adjust valves A and B until desired system temperature is obtained.

8. Bypass loop piping must be the same size piping for the supply and return.

MIXING-VALVE PIPING

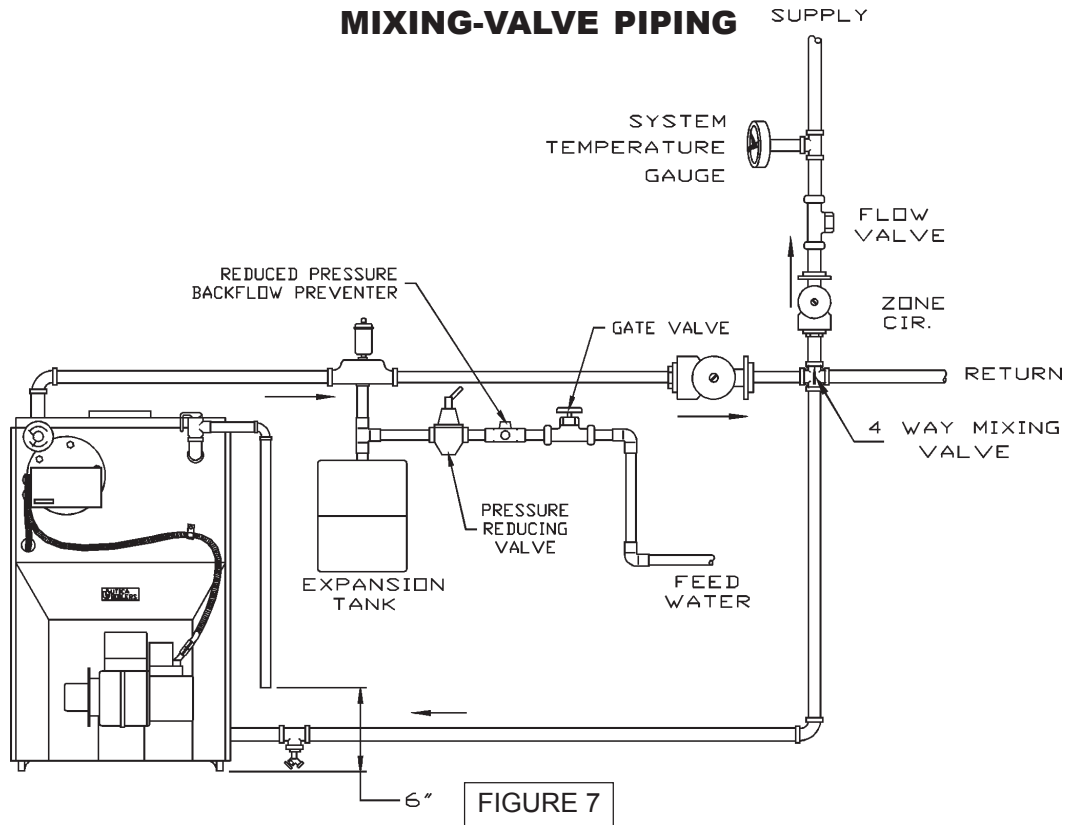

FIGURE 7

PRIMARY SECONDARY PIPING WITH BYPASS

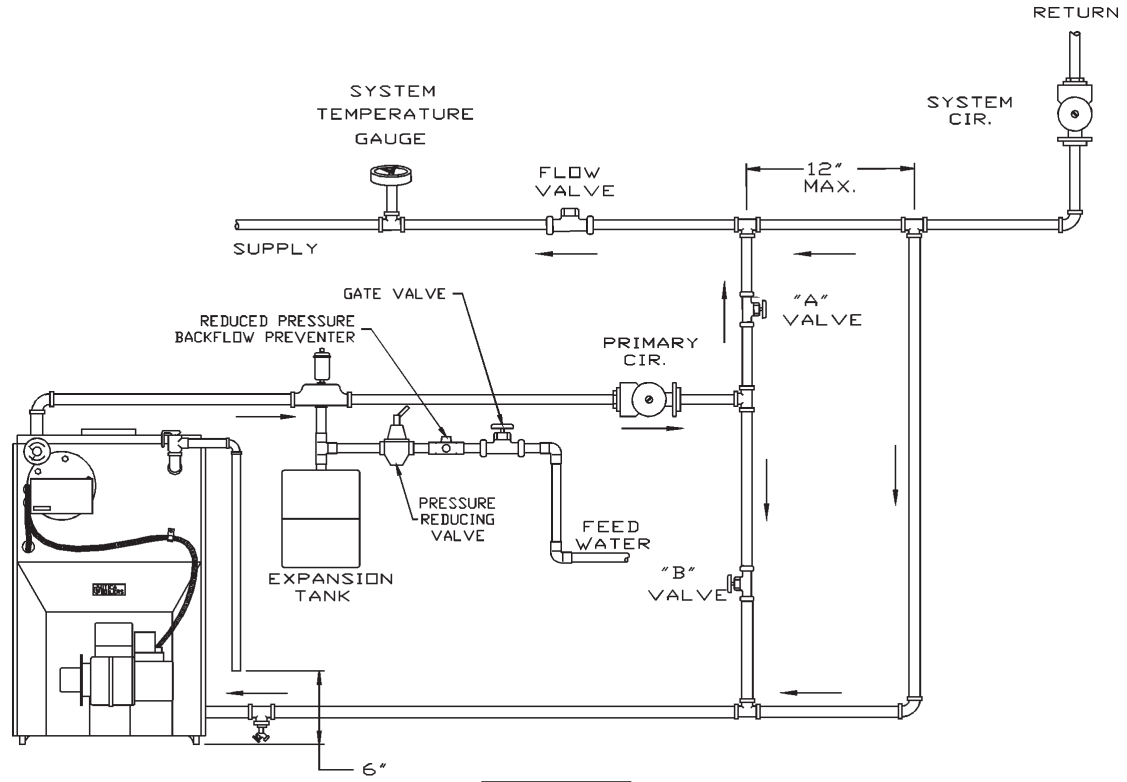
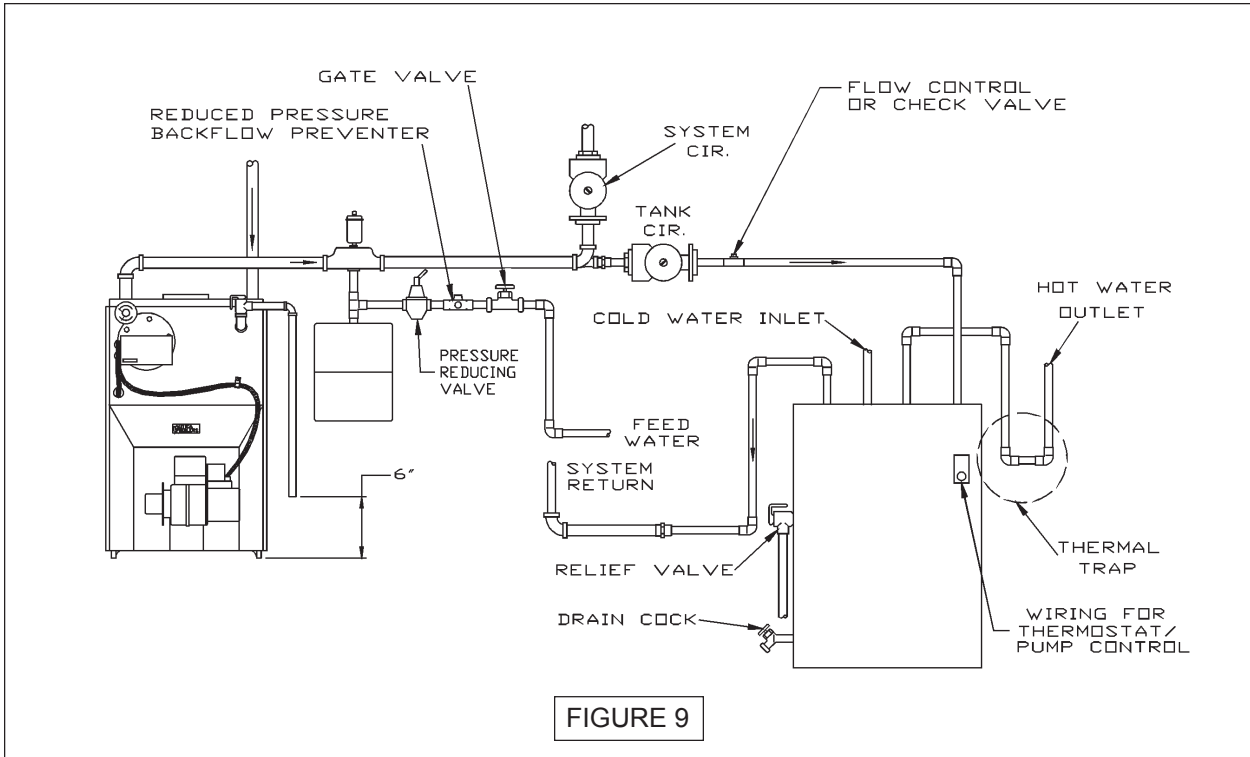

FIGURE 8

9. Typical installation using circulators is shown in figure 9, below.



10. Typical installation using zone valves is shown in figure 10, below.

11. For further piping information refer to the I=B=R installation and piping guide.

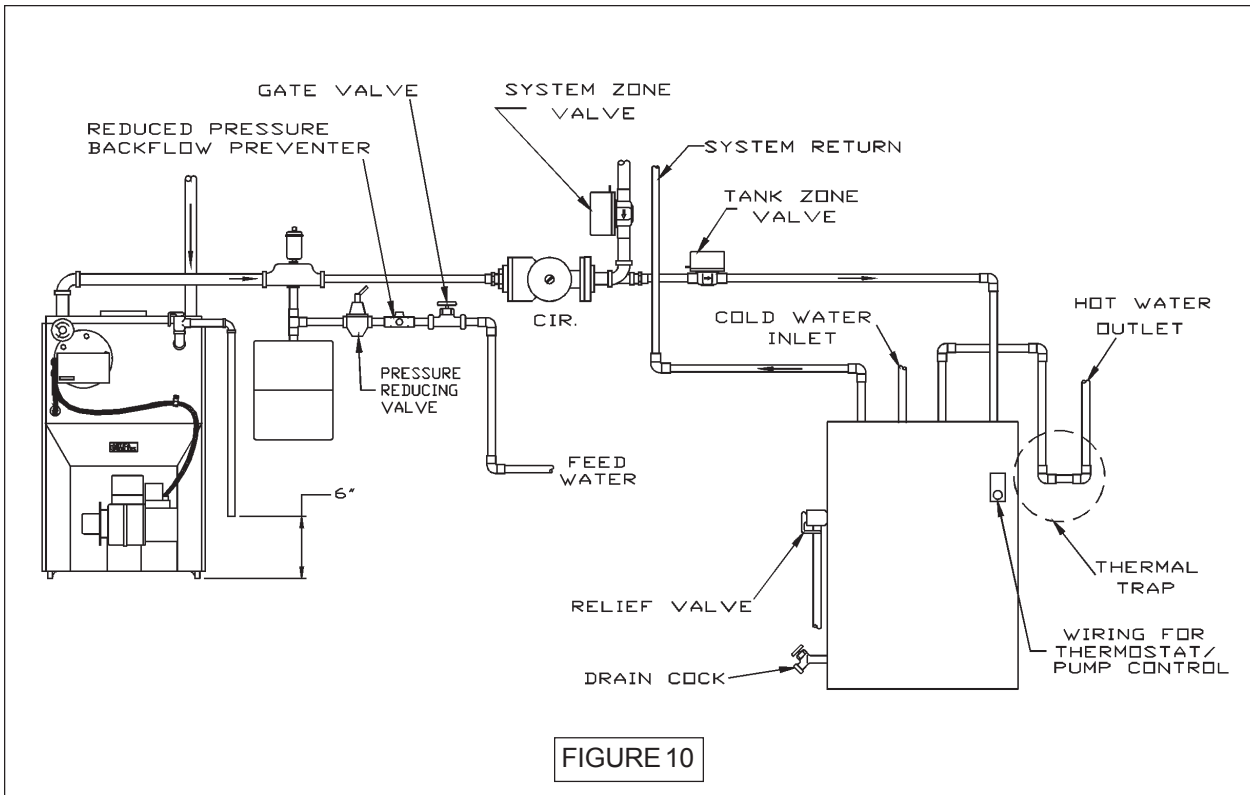

RECOMMENDED PIPING FOR BOILERS EQUIPPED WITH A T3 OR T4 TANKLESS HEATER

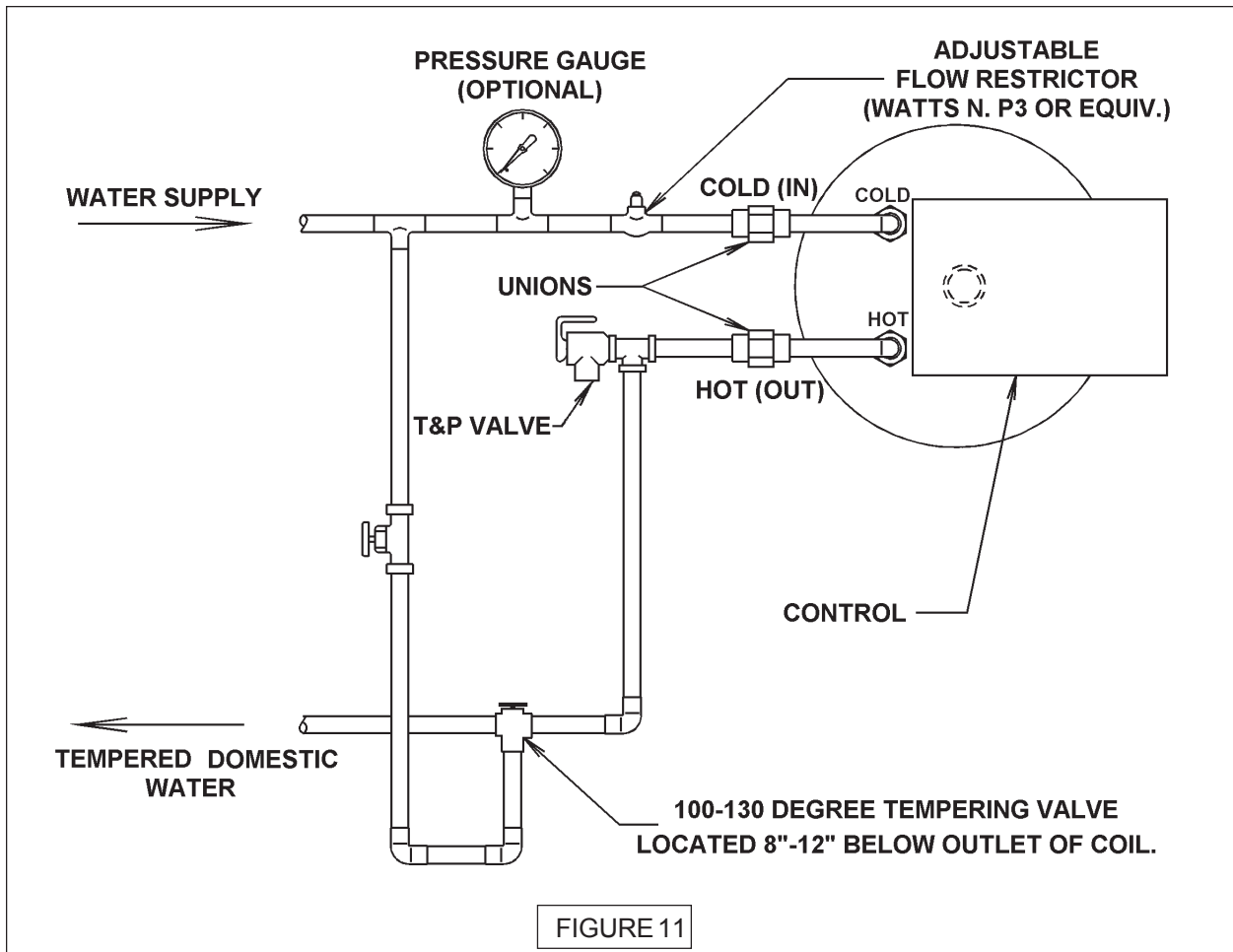

! DANGER:

Water temperatures exceeding 125° F will cause severe burns instantly or death by scalding.

- An automatic mixing valve must be installed on the outlet of the domestic coil. Installation must comply with the valve manufacturer's recommendations, and instructions.
- Do not remove the bolts or aquastat at the time of installation.
- Pipe in accordance with the installation manual.
- Due to varying water conditions, an adjustable flow restrictor must be installed in the cold water inlet of this coil.

OPTIONS UTILIZING 3/4" TAPPING

OPTIONAL LOCATION FOR AIR VENT

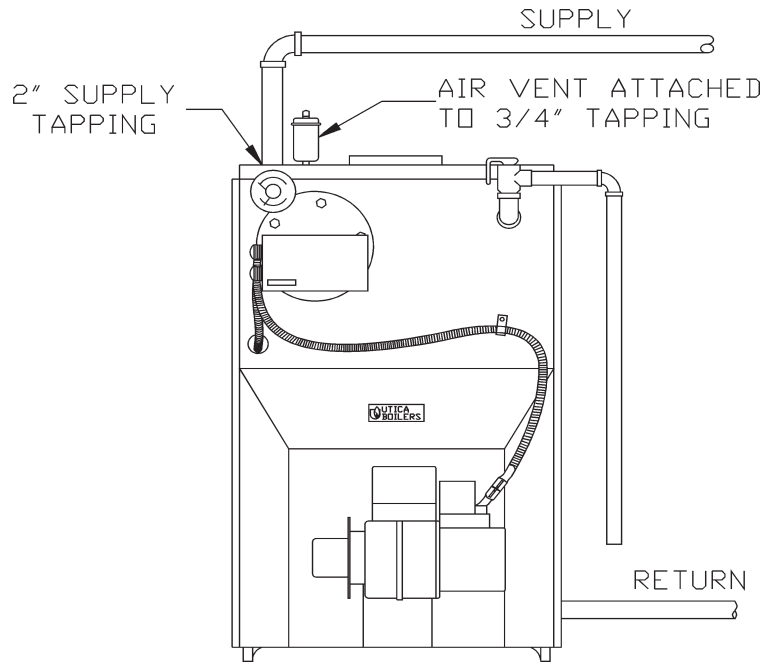

FIGURE 12

OPTIONAL LOCATION FOR EXPANSION TANK (NON-DIAPHRAM TYPE)

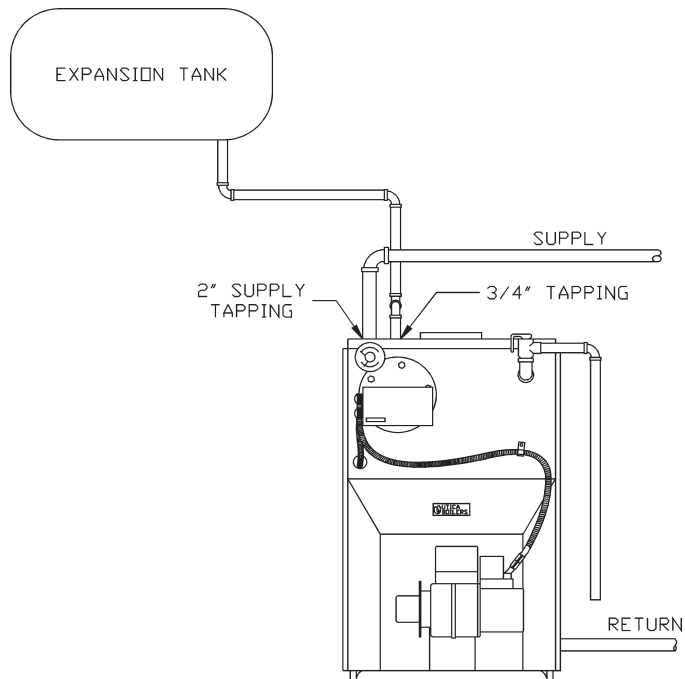

FIGURE 13

VENTING SYSTEM INSPECTION & INSTALLATION

! WARNING: BOILER IS TO BE VENTED BY NATURAL DRAFT AND SHALL NOT BE CONNECTED INTO ANY PORTION OF A MECHANICAL DRAFT SYSTEM OPERATING UNDER A POSITIVE PRESSURE.

INSPECT CHIMNEY to make certain it is constructed according to the latest revision of the NFPA211. Local codes may differ from this code and should be checked. Where there is a conflict, the local code will prevail. In Canada refer to the National Building Code or CSA-A405 as applicable.

This boiler must be installed into a chimney which has a masonry or metallic chimney liner.

An unlined chimney will have leaks that will cause poor chimney performance (NO DRAFT), and could result in poor positive pressure in the combustion chamber.

Horizontal portions of the venting system should not exceed 10 feet in length. Horizontal lengths over 10 feet will have a negative effect on the chimney performance.

The chimney should extend at least 2 feet above any portion of the building within 10 feet. See figure 14 below. It should produce a negative draft of .06 to .08 inches of water column, (W.C.), as measured with a draft gauge between the boiler and barometric draft control while maintaining an .02 inch W.C. negative draft in the combustion chamber. See chart below for recommended chimney or vent sizes.

Inadequate draft will cause improper combustion, resulting in dirty flue ways and high fuel bills.

CONNECT FLUE PIPE same size as boiler outlet to chimney, sloping upward continuously toward the chimney approximately 1/4" per foot. Bolt or screw joints together to avoid sag.

If an oil fired water heater is vented into the same flue as the boiler, provide a separate hole into the chimney whenever possible. When this isn't possible, use a "Y" connection in the flue pipe, using a separate draft regulator for each unit. When a chimney will not provide adequate draft to handle the input from the water heater and boiler simultaneously, wire the units so that only one will operate at a time, favoring the water heater.

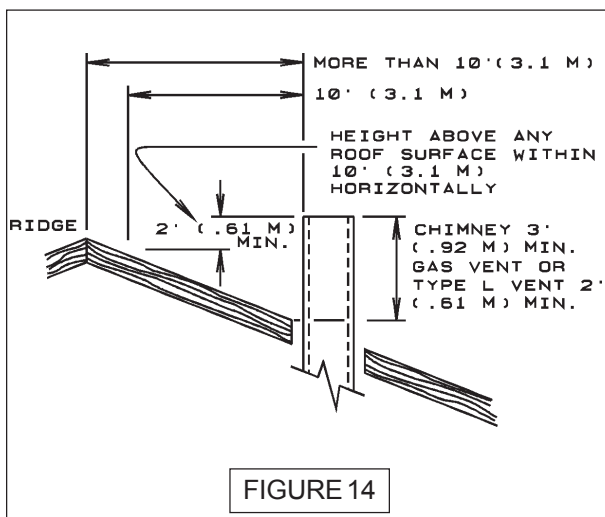

FIGURE 14

CHIMNEY OR VENT SIZES						
MODEL NO.	ROUND INCHES		SQUARE INCHES		HEIGHT FEET	
	MIN	MAX	MIN	MAX	MIN	MAX
SFH365,3100 4100	6	8	8X8	8X8	15	40
SFH4125,3125 4150,5125	7	8	8X8	8X10	15	40
SFH5175,5200	8	10	8X8	8X12	15	50
SFH6150,6225	8	10	8x8	8x12	15	50
SFH7275	8	10	8x8	8x12	15	50

OIL TANK AND PIPING

OIL TANK AND PIPING should be installed in accordance with the National Board of Fire Underwriters and local regulations. Oil storage tank, vent, fill pipe and caps should be as prescribed by local codes. In no case should the vent pipe be smaller than 1-1/4" I.P.S. The fill pipe should not be less than 2" I.P.S.

The suction line from the tank to the burner should be one continuous piece of tubing to prevent air entering the line. The suction line, must be 3/8" O.D. copper tubing for runs of 50 feet or less, and 1/2" O.D. for longer runs. An oil return line, same size as the suction line, must be used on any installation where the bottom of the tank is below the fuel unit of the burner. Oil lines should be buried or otherwise protected from mechanical injury. Flare fittings on all oil lines are recommended. Compression fittings on the suction line often allow air to be drawn into the fuel pump, making it difficult to maintain oil pressure at the nozzle. Do not run overhead fuel lines from tank to oil burner.

Fuel pump connections and by-pass should be made according to instructions attached to the fuel pump. If tank is more than 20' from the boiler, a two stage fuel unit should be installed in place of the single stage pump supplied as standard equipment with the burner. Make certain the rotation and speed are the same and the pump is suitable for the burner horsepower rating.

An oil line filter and shut-off valve should be installed in the suction line. Shut-off valves should be installed in both the suction and return lines at the burner for convenience in servicing burner. Allow extra tubing at burner so burner may be removed from boiler for cleaning without disconnecting tubing. (See figures 15 & 16, below). An optional flexible oil line is available.

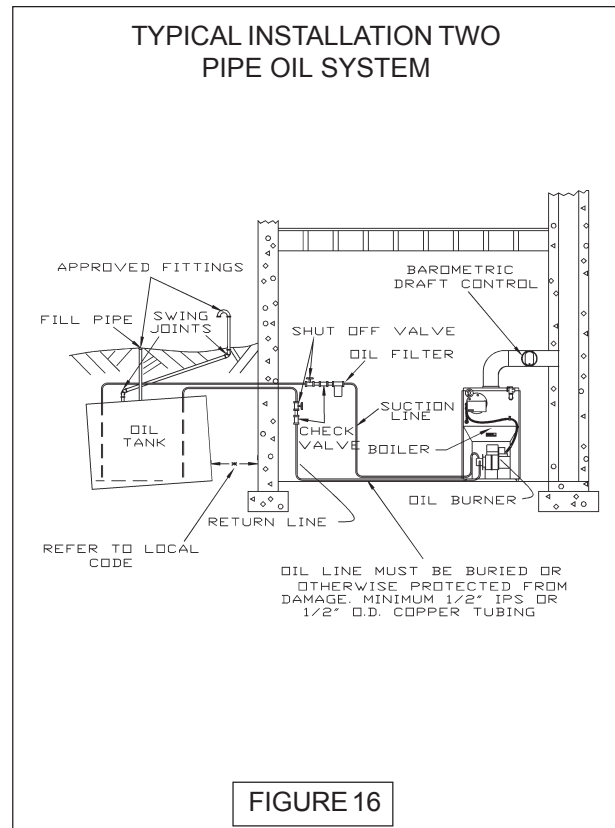
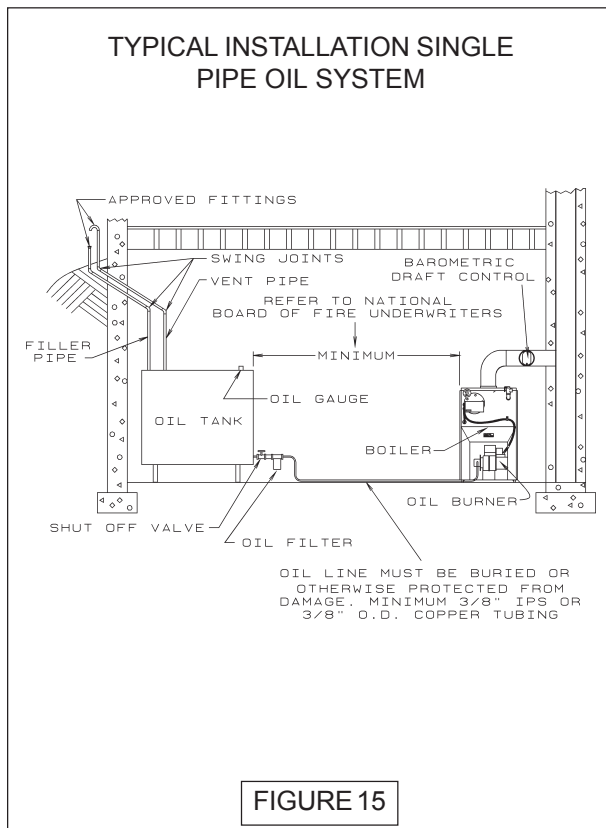

ELECTRICAL WIRING

SEE WIRING ADDENDUM FOR WIRING DIAGRAMS AND COMPONENT CODING.

Electrical wiring must conform with the National Electrical Code, ANSI/NFPA No. 70-1990 when installed in the United states, the CSA C22.1 Canadian Electrical Code, Part 1, when installed in Canada, and/or the local authority having jurisdiction.



WARNING:

1. When an external electrical source is utilized, the boiler, when installed **MUST BE** electrically grounded in accordance with these requirements.

2. Install a fused disconnect switch between boiler and meter at a convenient location.

THERMOSTAT INSTALLATION

1. Thermostat should be installed on an inside wall about four feet above the floor.
 2. NEVER install a thermostat on an outside wall.
 3. Do not install a thermostat where it will be affected by:
 - A. Drafts
 - B. Hot or cold pipes
 - C. Sun light
 - D. Lighting fixtures
 - E. Television sets
 - F. A fireplace or chimney
 4. Check thermostat operation by raising and lowering thermostat as required to start and stop the burner.
 5. Instructions for the final adjustment of the thermostat are packaged with the thermostat (adjusting heating anticipator, calibration, ect.).
-

NORMAL SEQUENCE OF OPERATION

On a call for heat, the thermostat will actuate, completing the circuit to the aquastat. In turn, the circulator and ignition systems are activated and ignition will begin. In the event the boiler water temperature exceeds the high limit setting on the boiler mounted aquastat, power will be interrupted between the aquastat and the ignition system. The power will remain off until the boiler water temperature drops below the high limit setting. The circulator will continue to operate under this condition until the thermostat is satisfied.

OPERATING INSTRUCTIONS

The venting system should be inspected at the start of each heating season. Check the vent pipe from the boiler to the chimney for signs of deterioration by rust or sagging joints. Repair if necessary.

Remove the vent pipe at the base of the chimney or flue and, using a mirror, check for obstruction.

The lever of the pressure relief valve, shown in Figure 19, on page 19, on the boiler should be operated periodically to make sure that it is functioning properly. The pressure relief valve should open before the water pressure exceeds the 30 lb. reading on the gauge. If this pressure is exceeded and the pressure relief valve leaks water when the boiler is operating at normal pressures, it should be immediately replaced. Corrosion can build up rapidly at the valve seat and prevent its functioning as a safety device.

 **WARNING:** WATER WILL BE BOILING HOT.

START-UP AND ADJUSTMENT OF OIL BURNER (See oil burner instructions for nozzle and electrode setting).

A. Check oil burner nozzle to make certain it is tight in adapter. Burner mounting bolts should be tight.

B. Check electrode setting, as they may have been jarred out of position during transportation.

C. Lubricate burner motor and circulator motor if required. Some circulators are water lubricated and do not require oiling.

D. Set room thermostat to call for heat, or jump thermostat contacts on the boiler control.

E. Open all oil line valves.

F. Turn service switch on. Burner should start.

G. On one pipe fuel systems only, vent pump as soon as burner starts. Allow oil to run until all traces of air in the suction line disappear.

H. Turn "OFF" burner and install pressure gauge port on pump.

I. Start burner again and check oil pressure for 140 lbs. Adjust if necessary.

 **CAUTION:** DO NOT SET FIRE VISUALLY.

Instruments are the only reliable method to determine proper air adjustments. An improperly adjusted burner causes soot and high fuel bills because of incomplete combustion of the fuel oil. This in turn may require excessive boiler maintenance, service costs, and in some instances, house cleaning or redecorating. A competent service mechanic should be consulted to make the proper adjustments with a smoke tester, CO₂ indicator and draft gauge. Bacharach or Dwyer test kits include these instruments.

INSTRUCTIONS TO OBTAIN PROPER OPERATION OF THE BOILER-BURNER UNIT

A 1/4" diameter slot is provided in the inspection cover plate to take draft readings in the combustion chamber. See figure 19, on page 19. A 1/4" diameter hole will be required in the flue pipe between the boiler and barometric damper (if used) to take draft, CO₂, smoke and temperature readings. Adjust air shutter on oil burner to obtain a "trace" of smoke. Measure CO₂ at this point. Increase air adjustment to lower CO₂ approximately one (1) percent. Check to insure minimum negative .02 W.C., (water column), "overfire" draft and

zero (0) smoke. If - .02 W.C. “overfire” draft can not be maintained, changes and/or modifications may be required in the venting or the chimney.

The table on page 18 is provided as a guideline for initial start-up. Final adjustments MUST be made using combustion instruments as previously mentioned.

CHECK SAFETY CONTROL CIRCUIT after burner adjustments have been made for satisfactory performance.

A. High limit control: remove cover and note temperature setting. See figure 19 on page 19. With the burner operating, decrease this setting to the minimum point. When boiler water temperature exceeds this set point, the high limit switch will open, shutting off the power to the oil burner. Return setting to desired high limit point. Burner should re-start.

B. Primary control and flame sensor:

To Check:

1. Flame failure - simulate by shutting off oil supply with hand valve while burner is on. Sixty seconds after flameout, the safety switch locks out, ignition stops, motor stops and oil valve - when used - closes. To restart, open oil supply valve and reset safety switch.

2. Ignition failure - with burner off, close oil supply valve and run through start-up procedure, The safety switch should lock out as in flame failure.

3. Power failure - Turn off main power supply switch while burner is operating. When burner stops, restore power and burner should start.

If operation is not as described as above, check wiring and controls.

PREVENTIVE MAINTENANCE of an oil fired boiler reduces operating costs. The boiler and vent pipe should be inspected for accumulation of soot or scale deposits periodically but at least once every year before the start of each heating season. When soot is present on the section walls and flueways, improper combustion will result, causing additional sooting and scaling until flueways are completely closed. To remove soot and scale from the flueways, remove top jacket panel, top clean-out plate, open burner swing door. (figure 19 on page 19).

PERIODIC INSPECTION and tightening of the tankless heater/cover plate bolts will reduce the risk of leaks. See Figure 21 on page 22.



- Use only number 2 fuel oil.
- Do not use gasoline, crankcase drainings or any oil containing gasoline.
- Do not attempt to start the burner when excess oil has accumulated, when the unit is full of vapor or when the combustion chamber is very hot.

RIELLO SETTINGS

BOILER NO.	BURNER NO.	AIR DAMPER	PUMP PRESS.	TURB.	NOZZLE FURNISHED
SFH365	F-3	4.0	150 PSI	0.0	.65 80W
SFH3100	F-5	3.6	150 PSI	1.0	.85 80W
SFH4100	F-5	3.6	150 PSI	1.0	.85 80W
SFH3125	F-5	4.0	150 PSI	3.0	1.10 60W
SFH4125	F-5	4.0	150 PSI	3.0	1.10 60W
SFH5125	F-5	4.0	150 PSI	3.0	1.10 60W
SFH4150	F-5	6.0	150 PSI	4.0	1.25 60W
SFH5175	F-10	3.6	150 PSI	0.0	1.50 80B
SFH5200	F-10	5.0	150 PSI	0.0	1.75 80B

CARLIN SETTINGS

BOILER NO.	BURNER NO.	AIR DAMPER	PUMP PRESS.	HEAD BAR	NOZZLE FURNISHED
SFH365	EZ-1	.60	150 PSI	60-.65	.60 70B
SFH3100	EZ-1	.85	150 PSI	.85-1.00	.85 70B
SFH4100	EZ-1	.85	150 PSI	.85-1.00	1.10 70B
SFH3125	N/A	N/A	N/A	N/A	N/A
SFH4125	EZ-1	1.00-1.10	150 PSI	1.10-1.25	1.10 70B
SFH5125	EZ-1	1.00-1.10	150 PSI	1.10-1.25	1.10 70B
SFH4150	EZ-1	1.25-1.35	150 PSI	1.10-1.25	1.25 70B
SFH5175	EZ-2	1.65	150 PSI	1.65-1.75	1.75 70B
SFH5200	EZ-2	1.75	150 PSI	1.65-1.75	1.50 70B

BECKETT SETTINGS

BOILER NO.	BURNER NO.	AIR BAND	AIR SHUT.	PUMP PRESS.	STATIC DISC	END CONE	NOZZLE FURNISHED
SFH365	AFG	0	7	140 PSI	2-3/4"	F0	.60 80B
SFH3100	AFG	1	5	140 PSI	3-3/8U	F3	.85 80B
SFH4100	AFG	1	5	140 PSI	3-3/8U	F3	.85 80B
SFH3125	AFII	N/A	6	140 PSI	N/A	N/A	1.10 60B
SFH4125	AFG	1	8	140 PSI	2-3/4"	F4	1.10 80B
SFH5125	AFG	1	8	140 PSI	2-3/4"	F4	1.10 80B
SFH4150	AFG	2	6	140 PSI	2-3/4"	F6	1.25 80B
SFH5175	AFG	3	5	140 PSI	3U	F12	1.50 80B H
SFH5200	AFG	5	5	140 PSI	3U	F12	1.75 70B H
SFH6225	CF375	3	6	140 PSI	L1	N/A	2.00 45B
SFH7275	CF375	5	4	140 PSI	L1	N/A	2.25 60B

*NOTE: Model SFH3125 needs pin # 5, SFH6225 needs a head setting of 0, & SFH7275 needs a head setting of 1.
Nozzle sizes with an H designation are Hago brand, all others are Delevan.

INSTRUCTIONS FOR OPENING BURNER SWING DOOR

1. Turn off power to boiler.
2. Allow boiler to cool down.
3. Disconnect power cable at factory supplied burner electrical disconnect.
See figure 19 below.
4. Loosen screws on the sides of the lower front jacket panel. See figure 19 below.
5. Pull the bottom part of the lower front panel forward.
6. Lift the lower front panel up and off the boiler. See figure 19 below.
7. Close oil valve. See figures 15, and 16 on page 13.
8. Disconnect oil line from burner.
9. Do not try to swing door with oil line attached.
10. Remove nut from swing door stud on right hand side of door.
11. Swing open burner and door to the left.

Using a flue brush, brush the soot and scale into the combustion space where it can be removed through the swing door opening.

CAUTION: USE CAUTION WHEN VACUUMING IN THE CHAMBER AREA. DAMAGE TO CHAMBER COULD RESULT.

It is recommended to replace the nozzle at the start of each heating season. Lubricate the burner motor and circulator motor - if required - with a few drops of a good grade of light motor oil. Do not over oil. Have a competent service person service the burner and check the controls and check the electrodes for carbon or cracks in the insulators. Burners should be adjusted to produce the conditions shown in Start-up and Adjustment of Oil Burner procedure.

INSTRUCTIONS FOR CLOSING BURNER SWING DOOR.

1. Swing burner and door to the right until insulation is slightly compressed and the stud is exposed.
2. Attach nut to the stud and tighten it until the built in stop contacts the mounting door.
3. Replace oil line to burner.
4. Replace lower jacket panel, and tighten the screws.
5. Connect the power cable at the factory supplied burner electrical disconnect.
6. Turn on power to boiler.
7. Bleed oil line.

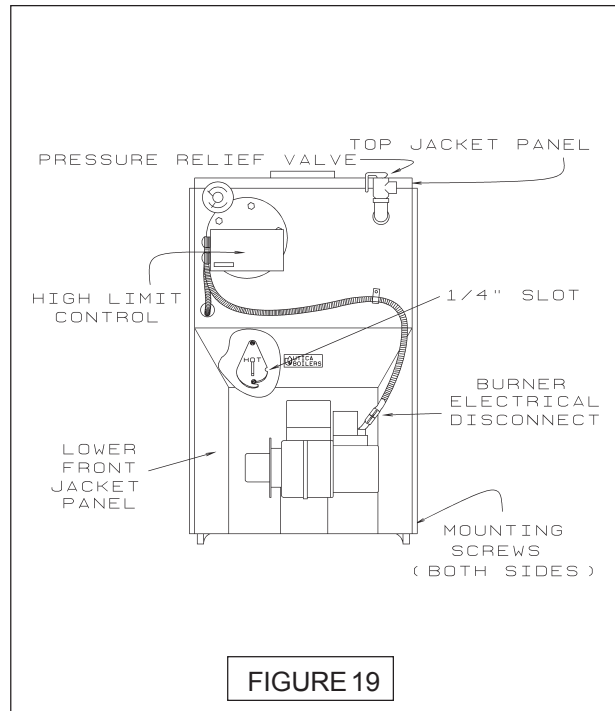

SERVICE CHECK LIST

- | | |
|--|---|
| <ul style="list-style-type: none"> <input type="checkbox"/> * Pump Pressure/Vacuum <input type="checkbox"/> * Line Voltage/Motor Amps <input type="checkbox"/> * Smoke Test <input type="checkbox"/> * Draft-Overfire/In Flue <input type="checkbox"/> * CO₂ or O₂ <input type="checkbox"/> * Flue Gas Temperature <input checked="" type="checkbox"/> X Proper Light-Off (Hot & Cold) <input checked="" type="checkbox"/> X Controls and Safety Devices | <ul style="list-style-type: none"> <input checked="" type="checkbox"/> X Inspect Chimney and Flue pipe <input checked="" type="checkbox"/> X Inspect and Clean Appliance <input checked="" type="checkbox"/> X Inspect Oil Line - Size/Leaks <input checked="" type="checkbox"/> X Inspect Electrical Connections <input checked="" type="checkbox"/> X Install New Filter <input checked="" type="checkbox"/> X Room Make-up Air <input checked="" type="checkbox"/> X Electrode setting <input type="checkbox"/> * Nozzle-Size, Angle, Type |
|--|---|

* Measure with Instruments and Record results on chart provided below.

Date	Nozzle			Pump Pressure PSI	Smoke NO.	Draft		CO ₂ or O ₂	Flue Temperature °F
	Size	Angle	Type			O.F.	INF		

SFH-W SERIES REPLACEMENT PARTS - HEAT EXCHANGER

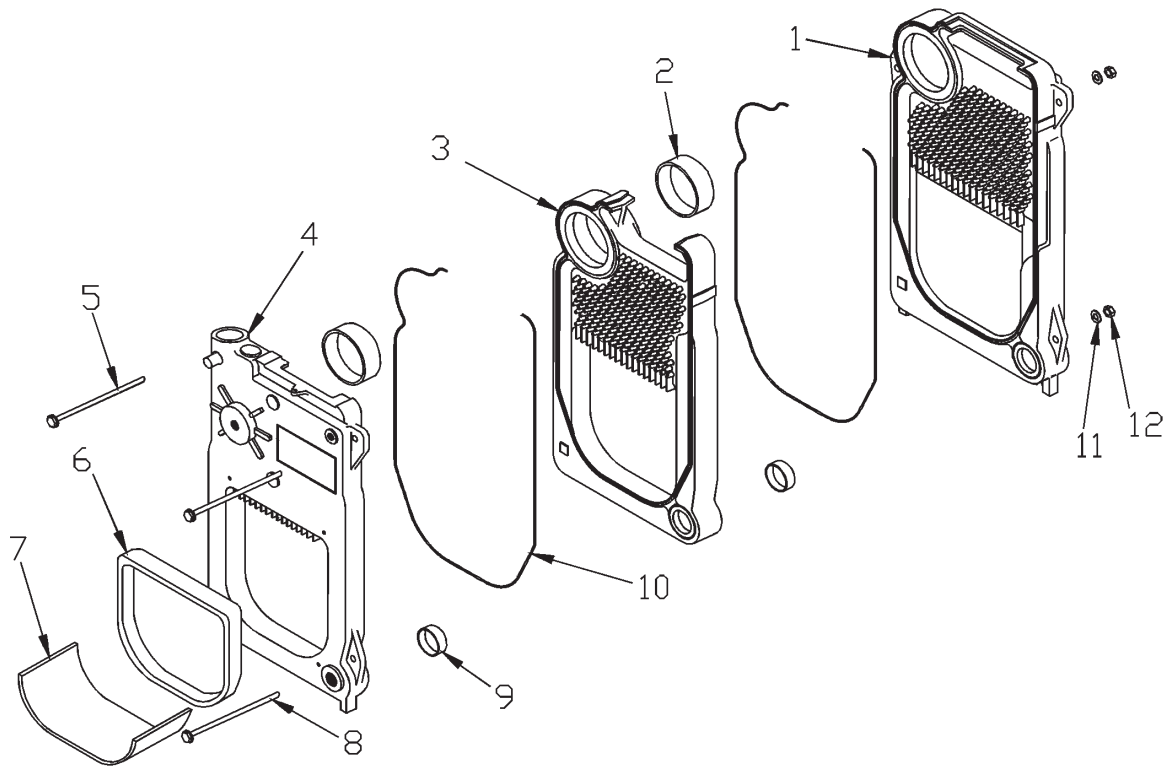

ITEM NO.	PART NO.	DISCRIPTION	QTY	ITEM NO.	PART NO.	DISCRIPTION	QTY
1	10051701	REAR SECTION	1	5 SECTION (4)	6 SECTION (5)		
2	100-1-8.01	#60 PUSH NIPPLE		7 SECTION (6)			
		3 SECTION (2)		10	MS-006.00	ROPE MED DENSITY	1
		4 SECTION (3)			3 SECTION (13')	4 SECTION (19.5')	
		5 SECTION (4)			5 SECTION (26')	6 SECTION (32.5')	
		6 SECTION (5)			7 SECTION (39')		
3	10051101	CENTER SECTION		11	HW-008.03	WASHER 1/2 ID FLAT	3
		3 SECTION (1)		12	HW-003.05	NUT 1/2-13 HEX HEAD	3
		4 SECTION (2)					
		5 SECTION (3)					
		6 SECTION (4)					
		7 SECTION (5)					
4	10051201	FRONT SECT. CASTOVER	1	FULLY ASSEMBLED HEAT EXCHANGERS			
	10051301	FRONT SECT. TANKLESS COIL		10023101		3 SECT. TNKLS W/O COIL	
5	HW02510	TIE ROD 1/2X10.5/8 (3 SEC)	2	10023102		4 SECT. TNKLS W/O COIL	
	HW02511	TIE ROD 1/2X14.1/4 (4 SEC)		10023103		5 SECT. TNKLS W/O COIL	
	HW02512	TIE ROD 1/2X17.7/8 (5 SEC)		10023104		6 SECT. TNKLS W/O COIL	
	HW02514	TIE ROD 1/2X21.3/4 (6 SEC)		10023105		7 SECT. TNKLS W/O COIL	
	HW02515	TIE ROD 1/2X25.1/4 (7 SEC)					
6	5611508	KIT - TARGET WALL & INSULATION BLANKET	1	10023201		3 SECT. WITH TANKLESS COIL	
				10023202		4 SECT. WITH TANKLESS COIL	
7	25511005	INSUL BLANKET 16X24 (6 & 7 SECTION)	1	10023203		5 SECT. WITH TANKLESS COIL	
				10023204		6 SECT. WITH TANKLESS COIL	
				10023205		7 SECT. WITH TANKLESS COIL	
8	HW-025.01	TIE ROD 1/2X12.1/2 (4 SEC)	1				
	HW-025.02	TIE ROD 1/2X16.1/2 (5 SEC)		10023301		3 SEC. WITH CAST OVER	
	HW-025.03	TIE ROD 1/2X20.1/2 (6 SEC)		10023302		4 SEC. WITH CAST OVER	
	HW-025.05	TIE ROD 1/2X9 (3 SEC)		10023303		5 SEC. WITH CAST OVER	
	HW-025.09	TIE ROD 1/2X23.1/2 (7 SEC)		10023304		6 SEC. WITH CAST OVER	
9	100-1-5.01	#22 PUSH NIPPLE		10023305		7 SEC. WITH CAST OVER	
		3 SECTION (2)					
		4 SECTION (3)					

FIGURE 20

SFH-W SERIES REPLACEMENT PARTS - COIL

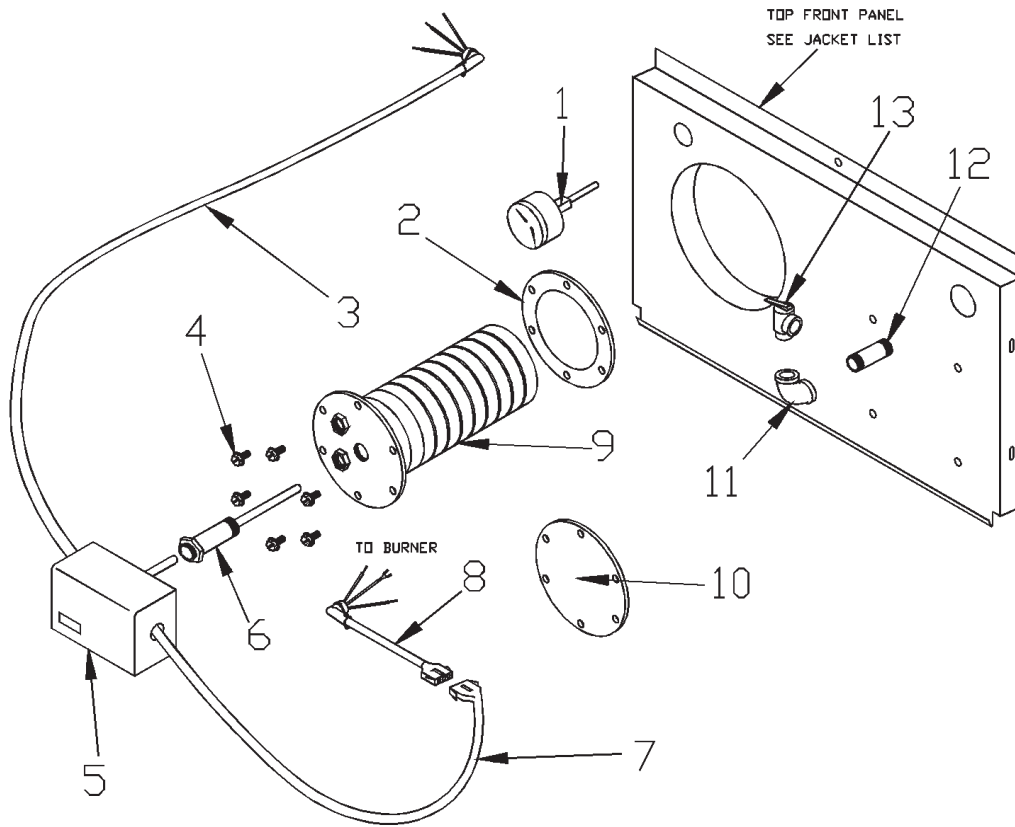

ITEM NO.	PART NO.	DISCRIPTION	QTY
1	GA-001.00	GAUGE THEALTIMETER, WATER	1
2	2551401	GASKET - SILICON/DURO 70	1
3	37519501	HARNESS CIRCULATOR 72"	1
4	HW08001	BOLT 5/16" X 3/4"	6
5	1010001	CONTROL L8148A (FOR BOILERS WITHOUT A TANKLESS COIL)	1
	AQ-010.00	CONTROL L8124A (FOR BOILERS WITH A TANKLESS COIL)	
6	AQ-020.01	WELL	1
7	28511801	HARNESS CTRL BOX (BECKETT OR RIELLO)	1
	28511801	HARNESS AQUASTAT (FOR CARLIN BUNERS ONLY)	
8	1263013	HARNESS, BURNER (FOR BECKETT BURNERS ONLY)	1
	1263011	HARNESS, BURNER (FOR RIELLO BURNERS ONLY)	
	28511901	HARNESS, BURNER (FOR CARLIN BURNERS ONLY)	
9	5612001	TANKLESS COIL KIT P3 (FOR 3 SECTION BOILERS)	1
	5612002	TANKLESS COIL KIT T4 (4, 5,6, & 7 SECT. BOILERS)	
		(ABOVE KITS INCLUDE ITEM NOS. 2,4, AND THE APPROPRIATE COIL.)	
10	27511401	TANKLESS - COVER KIT (KIT INCLUDES ITEM NOS. 2,4, AND COVER PLATE)	1
11	1190001	PIPE FIT ELBOW 3/4" NPT	1
12	PF-005.11	PIPE FIT - NPL 3/4" X 4" NPT	1
13	VR-001.01	RELIEF VALVE 30#	1

FIGURE 21

SFH-W SERIES REPLACEMENT PARTS SWING DOOR AND MOUNTING DOOR COMPONENTS

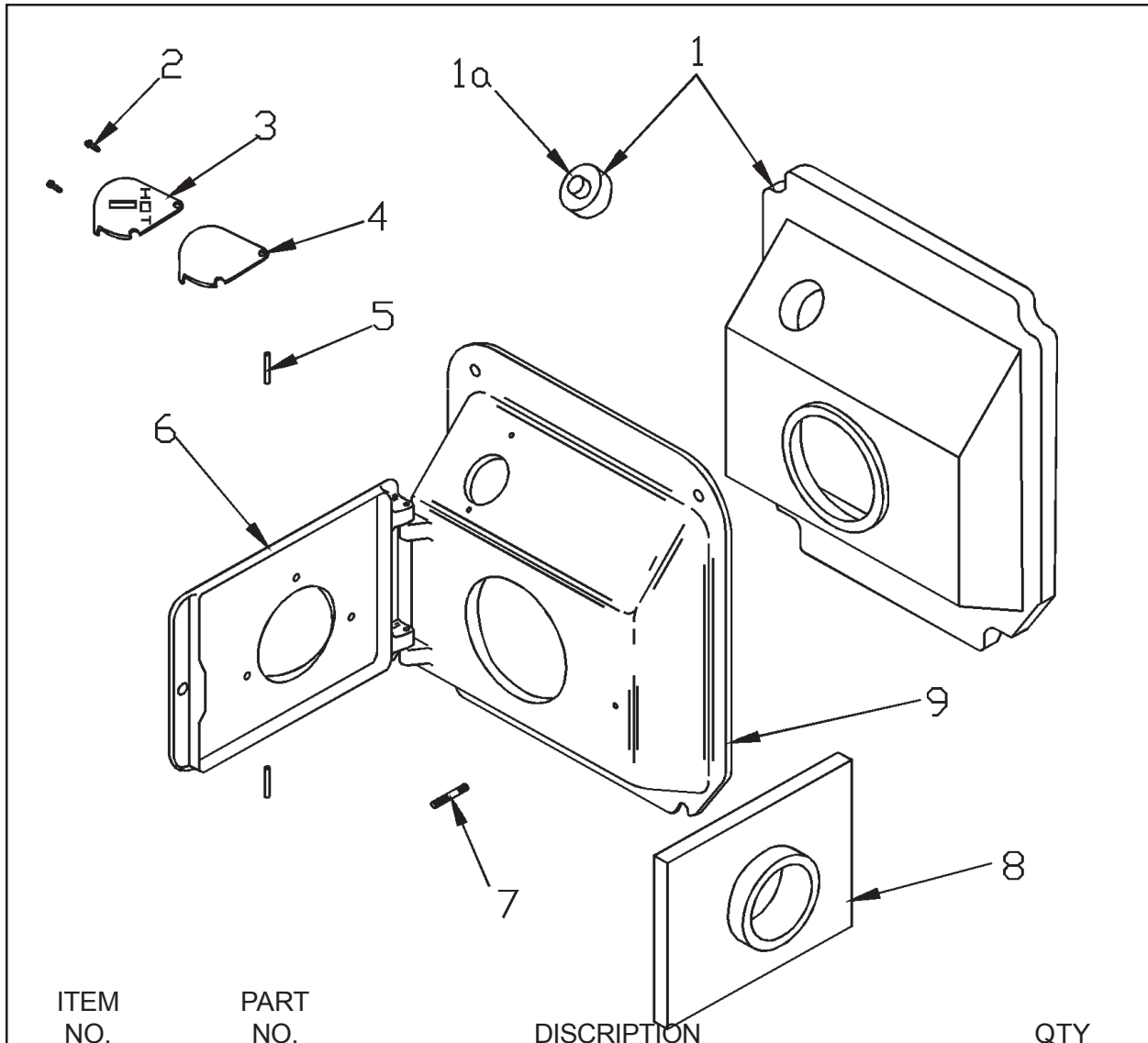

ITEM NO.	PART NO.	DISCRIPTION	QTY
1	2552901	MOUNTING DOOR INSULATION & PLUG	1
2	HW-005.01	SCREW 1/4-20X1/2 SELF TAPPING	2
3	10011701	OBSERVATION DOOR	1
4	25511101	OBS. DOOR GASKET	1
5	HW06801	1/4X1.3/4 DRIVE LOCK PIN	2
6	10011501	SWING DOOR	1
7	HW06701	5/16X18X2.3/8 STUD	1
8	2553301	INSULATION-SWING DOOR	1
		(FOR BOILERS WITH RIELLO BURNERS ONLY)	
	2553303	INSULATION-SWING DOOR	1
		(FOR BOILERS WITH BECKETT OR CARLIN BURNERS)	
9	10011301	MOUNTING DOOR	1

FIGURE 22

SFH-W SERIES REPLACEMENT PARTS - JACKETS

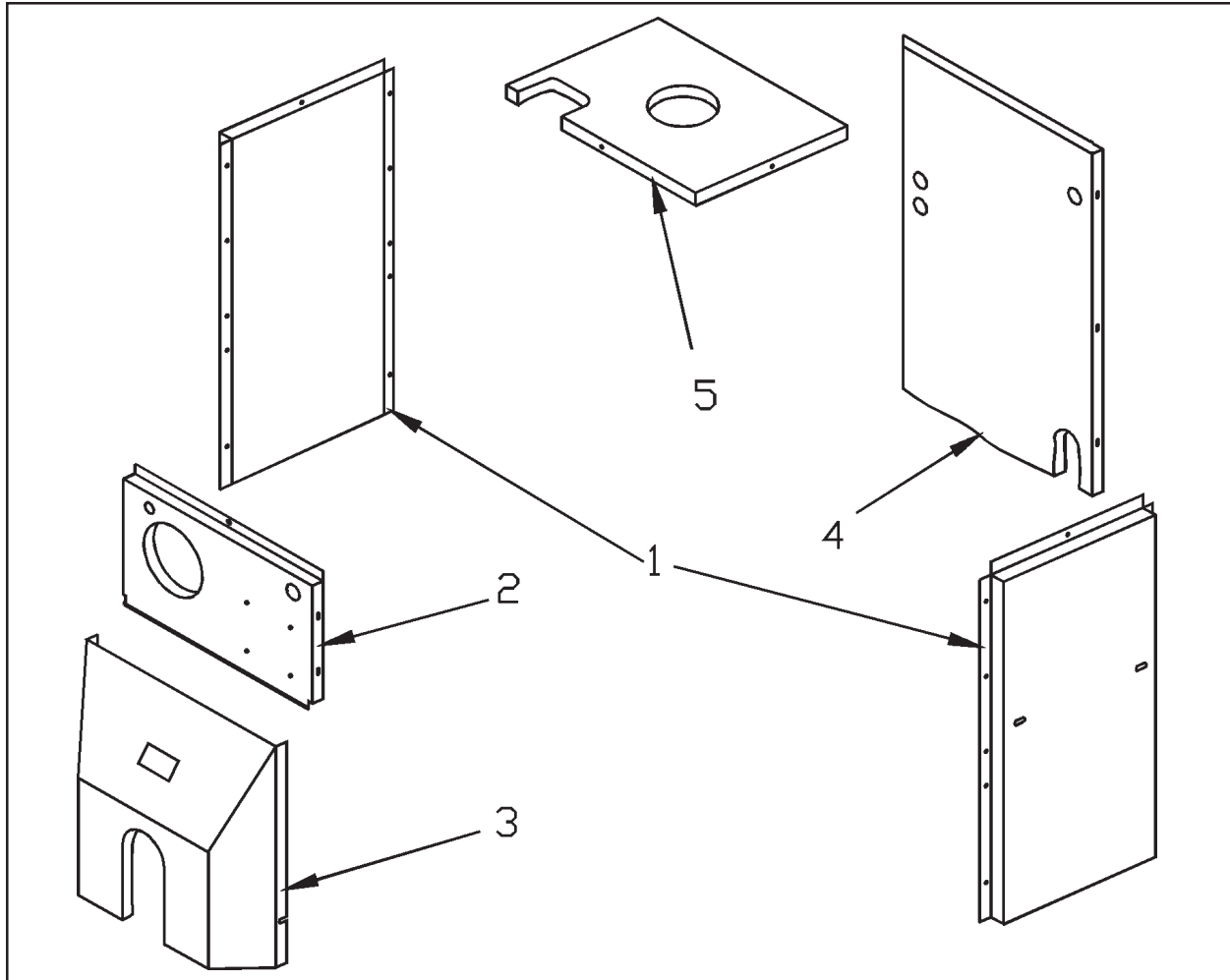

ITEM NO.	PART NO.	DISCRIPTION	QTY
1	21521802	SIDE PANEL 3 SECTION	2
	21521803	SIDE PANEL 4 SECTION	
	21521804	SIDE PANEL 5 SECTION	
	21521805	SIDE PANEL 6 SECTION	
	21521806	SIDE PANEL 7 SECTION	
	21522401	TOP FRONT PANEL C/O	
21522402	TOP FRONT PANEL TNKLS COIL (SHOWN)		
3	21521901	LOWER COWL	1
4	21521501	REAR PANEL	1
5	215-1-3.02	TOP PANEL 3 SECTION	1
	215-1-3.03	TOP PANEL 4 SECTION	
	215-1-3.04	TOP PANEL 5 SECTION	
	2151307	TOP PANEL 6 SECTION	
	2151308	TOP PANEL 7 SECTION	

FIGURE 23

SFH-W SERIES REPLACEMENT PARTS - HARDWARE

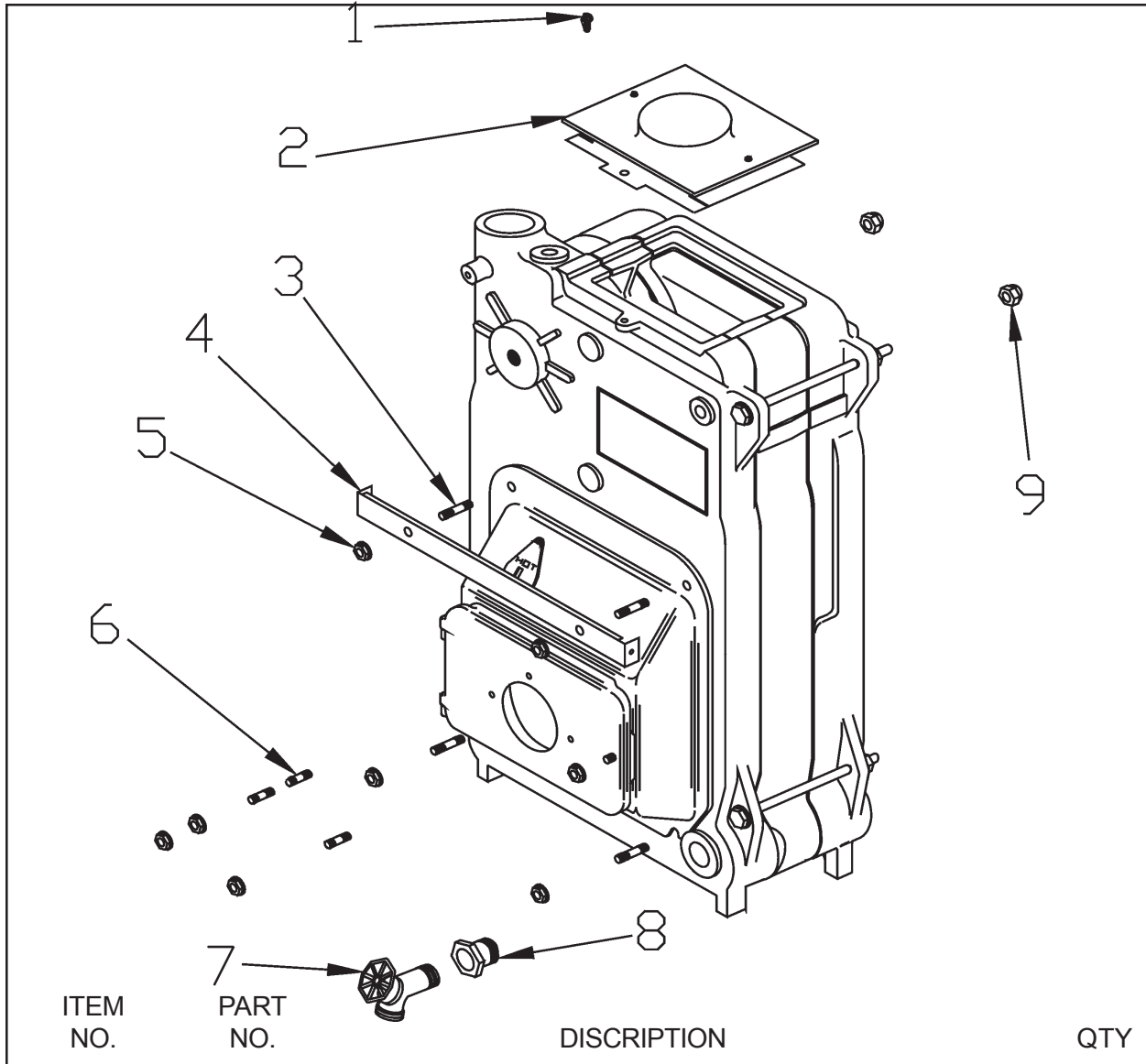

ITEM NO.	PART NO.	DISCRIPTION	QTY
1	HW-005.01	SCREW 1/4-20X1/2 SELF TAP	1
2	2452902	FLUE COLLECTOR ASSY (4 SECT)	1
	2452903	FLUE COLLECTOR ASSY (5 SECT)	
	2452906	FLUE COLLECTOR ASSY (3 SECT)	
	2452907	FLUE COLLECTOR ASSY (6 SECT)	
	2452908	FLUE COLLECTOR ASSY (7 SECT)	
3	HW06701	STUD 5/16"-18 X 2.3/8"	4
4	2252501	SUPPORT JACKET BRACKET	1
5	HW06901	NUT 5/16-18 WISLOCK	8
6	HW07001	STUD 5/16"-18 X 1.1/8"	3
7	HW-016.02	DRAIN LONG	1
8	1060003	PIPE FIT BUSHING 1.1/4" X 3/4"	
9	HW06401	NUT - ACORN 1/2"-13 UNC YELLOW	2

FIGURE 24

SFH-W REPLACEMENT PARTS BURNER COMPONENTS

ITEM NO.	PART NO.	DISCRIPTION	QTY.
1	BN04001	BURNER OIL UT901C BECKETT (SFH365)	1
	BN04002	BURNER OIL UT902C BECKETT (SFH3100,&SFH4100)	
	BN04004	BURNER OIL UT904C BECKETT (SFH4125, SFH4150, & SFH5125)	
	BN04006	BURNER OIL UT906C BECKETT (SFH5200, & SFH5175)	
	BN08901	BURNER OIL UT1801 BECKETT (SFH6225 & SFH7275)	
	BN06003	BURNER OIL UT1103C BECKETT (SFH3125)	
	30A064201	BURNER OIL RIELLO 40/F3 (SFH365)	
	1050006	BURNER OIL RIELLO 40/F5 (SFH3100, 4100, 4125, 4150, & 5125)	
	BN07007	BURNER OIL RIELLO 40/F10 (SFH5175 & SFH5200)	
	BN08401	BURNER OIL CARLIN EZ-1 (SFH365, SFH3100, & SFH4100)	
	BN08402	BURNER OIL CARLIN EZ-1 (SFH4125, SFH4150, & SFH5125)	
	BN08403	BURNER OIL CARLIN EZ-2 (SFH5175, & SFH5200)	
2	BN08001	BURNER OIL FLANGE GASKET #3616	1
	30A055901	GASKET OB MT FLG #3416	1
3	CD-001.01	CAD CELL (FOR BOILERS WITH BECKETT OR CARLIN BURNERS ONLY)	1
4	RY-001.01	CONTROL R8184G (CONTROL FOR BOILERS WITHOUT COIL) (FOR BOILERS WITH CARLIN BURNERS ONLY)	1
	RY-001.02	CONTROL R4184D (TANKLESS COIL CONTROL) (FOR BOILERS WITH CARLIN BURNERS ONLY)	
	RY00701	CONTROL R7184B 1032 (7456U) (FOR BOILERS WITH BECKETT BURNERS ONLY)	
5	1320003	NOZZLE .60 80B (SFH365 BECKETT)	1
	1320004	NOZZLE .85 80B (SFH3100 & SFH4100 BECKETT)	
	NZ-002.08	NOZZLE 1.10 80B (SFH4125 & SFH5125 BECKETT)	
	NZ-002.10	NOZZLE 1.25 80B (SFH4150 BECKETT)	
	NZ-002.12	NOZZLE 1.50 80B (SFH5175 BECKETT)	
	NZ00206	NOZZLE 1.75 80B (SFH5200 BECKETT)	
	NZ01201	NOZZLE 2.00 45B (SFH6225 BECKETT)	
	14619346	NOZZLE 2.25 45B (SFH7275 BECKETT)	
	NZ00801	NOZZLE .65 80W (SFH365 RIELLO)	
	NZ00802	NOZZLE .85 80W (SFH3100 & SFH4100 RIELLO)	
	1320012	NOZZLE 1.10 60W (SFH3125, SFH4125, & SFH5125 RIELLO)	
	1320013	NOZZLE 1.25 60W (SFH4150 RIELLO)	
	NZ-002.12	NOZZLE 1.50 80B (SFH5175 RIELLO)	
	NZ00206	NOZZLE 1.75 80B (SFH5200 RIELLO)	
	NZ00901	NOZZLE .60 70B (SFH365 CARLIN)	
	NZ00902	NOZZLE .85 70B (SFH3100, & SFH4100 CARLIN)	
	NZ00903	NOZZLE 1.10 70B (SFH4125, & SFH5125 CARLIN)	
	NZ00904	NOZZLE 1.25 70B (SFH4150 CARLIN)	
	NZ00905	NOZZLE 1.75 70B (SFH5200 CARLIN)	
	NZ00906	NOZZLE 1.50 70B (SFH5175 CARLIN)	

SFH-REPLACEMENT PARTS BURNER COMPONENTS

BECKETT AFG BURNER PARTS

(USED ON ALL SFH BOILER MODELS WITH BECKETT BURNERS EXCEPT SFH3125,
SFH6225, AND SFH7275)

ITEM NO.	PART NO.	DISCRIPTION
1	RP03801	BLAST TUBE AFG/SFH
2	RP03701	FUEL PUMP, 1 STAGE, 140 PSI, AFG
	RP03702	FUEL PUMP, 2 STAGE, 140 PSI, AFG
3	BN07102	DRAWER ASSEMBLY (OIL LINE), AFG
4	BN08001	BURNER GASKET
5	RP-015.00	MOTOR
6	1050007	TRANSFORMER

BECKETT AFII BURNER PARTS

(USED ON MODEL SFH3125 ONLY)

ITEM NO.	PART NO.	DISCRIPTION
1	RP03802	BLAST TUBE AF2
2	RP03901	FUEL PUMP AF2 DANFOSS
3	RP04001	7" DRAWER ASSY AF2
4	RP04101	OIL BRN TRANSFORMER AF2
5	RP04201	OIL BRN MOTOR AF2

BECKETT CF375 BURNER PARTS

(USED ON MODELS SFH6225 & SFH7275)

ITEM NO.	PART NO.	DISCRIPTION
1	RP04501	FUEL PUMP, CLEAN CUT (21844U)
2	RP-015.00	MOTOR, PSC (21805U)
3	1050007	TRANSFORMER, (51771U)
4	RP04601	OIL BURNER VALVE COIL KIT (21755U)

SFH-REPLACEMENT PARTS BURNER COMPONENTS

CARLIN BURNER PARTS

ITEM NO.	PART NO.	DISCRIPTION
1	BN08601	BRN HEAD BAR .6-.65 SFH365
	BN08602	BRN HEAD BAR .85-1 SFH3100 & SFH4100
	BN08603	BRN HEAD BAR 1.1-1.25 SFH4125, SFH4150, & SFH5125
	BN08604	BRN HEAD BAR 1.65-1.75 CSFH5175 & SFH5200

RIELLO BURNER PARTS

ITEM NO.	PART NO.	DISCRIPTION
1	30A064701	BRN PUMP DRIVE KEY RIELLO
2	30A064801	BRN PRIMARY CTRL-530SE RIELLO
3	30A064901	BRN COIL RIELLO
4	30A065101	BRN MOTOR RIELLO
5	30A065201	BRN CAPACITOR 12.5uF RIELLO
6	30A065301	BRN ELECTRODE PORCELAIN RIELLO
7	30A065401	BRN PUMP RIELLO
8	30A065501	BRN HYDRAULIC JACK RIELLO
9	30A065601	BRN O-RING PUMP PRESS RIELLO
10	30A065701	BRN PHOTO CELL RIELLO

RATINGS AND DATA

(1) BOILER MODEL NUMBER	(2)* I=B=R OIL BURNER INPUT		D.O.E. HEATING CAPACITY	(3)(4)* I=B=R NET RATINGS	MINIMUM NATURAL DRAFT		PUMP PRESSURE	A. F. U. E. RATING
	G.P.H.	MBH		WATER MBH	CHIMNEY SIZE			
			ROUND		SQUARE	PSI		
SFH-365	.65	91	79	68.7	6	8X8X15	140	86.0
SFH-3100	1.00	140	117	102	6	8X8X15	140	81.0
SFH-3125	1.25	175	144	125	7	8X8X15	140	80.0
SFH-4100	1.00	140	120	104	6	8X8X15	140	86.0
SFH-4125	1.25	175	149	130	7	8X8X15	140	82.5
SFH-5125	1.25	175	151	131	7	8X8X15	140	86.0
SFH-4150	1.50	210	175	152	7	8X8X15	140	81.0
SFH-5175	1.75	245	206	179	8	8X8X15	140	81.5
SFH-5200	2.00	280	231	210	8	8X8X15	140	81.0
SFH-6150	1.50	210	181	157	8	8X8X15	140	86.0
SFH-6225	2.25	315	254	221.0	8	8X12X15	140	-----
SFH-7275	2.75	385	307	267.1	8	8X12X15	140	-----

SEE BACK COVER FOR NOTE REFERENCES.

STANDARD EQUIPMENT: Crated Boiler, Flush Jacket, Oil Burner, Target Wall/Liner, Circulator-1.1/4", ASME Relief Valve, Therallitimeter Gauge, Drain Cock, Wiring Harness, Burner Electrical Disconnect, Plastic Cover, Supply Tapping-2", Return Tapping-1.1/4", High Limit and Circulator Control, Primary Control. For Tankless Heater Units-add Tankless Hot Water Coil, Flow Restrictor and Triple Aquastat Relay.

TANKLESS WATER HEATER CAPACITIES

BOILER MODEL NUMBER	FIRING RATE G.P.H.	TANKLESS HEATER NUMBER	TANKLESS HEATER CAPACITY INTERMITTENT DRAW G.P.M.	BOILER WATER CONTENT GALS.
SFH-365	.65	T3	available on request	10.5
SFH-3100	1.00	T3	3.25	10.5
SFH-4100	1.00	T4	3.25	13.5
SFH-3125	1.25	T3	3.75	10.5
SFH-4125	1.25	T4	3.75	13.5
SFH-5125	1.25	T4	3.75	16.5
SFH-4150	1.50	T4	4.00	13.5
SFH-6150	1.50	T4	4.00	19.5
SFH-5175	1.75	T4	4.25	16.5
SFH-5200	2.00	T4	5.50	16.5
SFH-6225	2.25	T4	5.75	19.5
SFH-7275	2.75	T4	6.00	22.5

DIMENSIONS

BOILER NO.	A LENGTH OF FLUSH JACKET	B FRONT OF CASTING TO CENTER LINE OF FLUE OUTLET	C DIA. OF FLUE OUTLET
SFH-3	17.7/8"	11.1/4"	6"
SFH-4	21.1/2"	12.5/8"	6"
SFH-5	25.1/8"	14.1/4"	7"
SFH-6	29.1/4"	15.15/16"	8"
SFH-7	32.7/8"	17.15/16"	8"

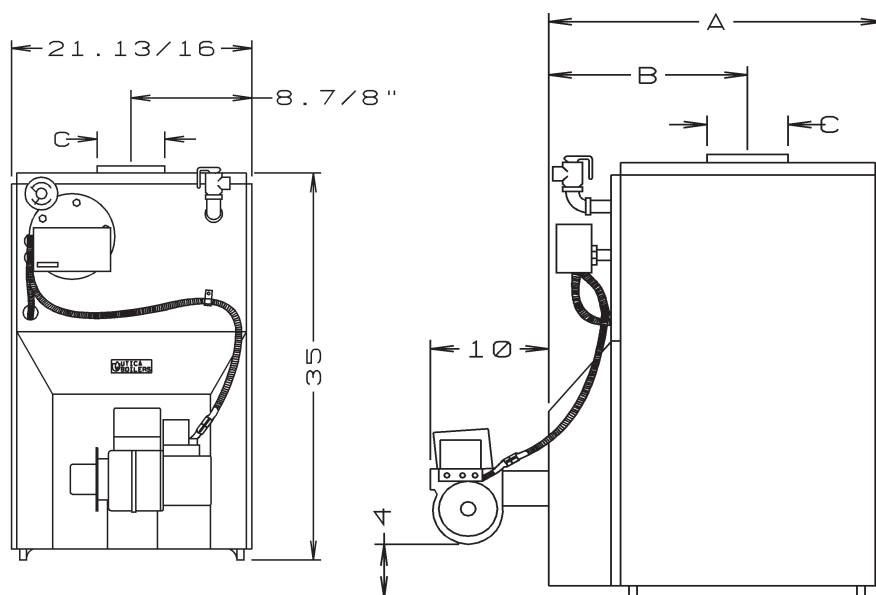

NOTES:

1. Add suffix "T" to denote boiler with tankless heater.
2. I=B=R burner capacity is based on an oil heating value of 140,000 Btu/gal. and with 13% CO².
3. Net ratings based on 170 °F temperature in radiators and include 15% allowance for normal piping and pickup load. Consult manufacturers for unusual piping and pick-up requirements.
* All ratings subject to verification.
4. For equivalent square feet of radiation, divide I=B=R output by 150.
5. 120 Volts, 15 Amps, & 60 Hz. required to operate this boiler.
6. The MEA number for the SFH-W series is 182-86E
7. For altitudes above 2,000 ft. ratings may be reduced at the rate of 4% for every 1,000 ft. above sea level.
7. The MEA number for the Beckett burners used on the SFH-W are as follows:

AF	156-77-E
AFG	213-83-E
AFII 85	24-92-E
AFII 150	456-90-E