

HM

HeatMaster

Installation, Operating and Servicing Instructions

HM 60 N / 70 N / 100 N / 150 JUMBO

HM 60 N / 70 N / 100 N
With ACV BG 2000-S premix gas burner

HM 60 N / 70 N / 100 N
With ACV BM 101 oil burner

HM 150 JUMBO
With ACV BM 151 oil burner



excellence in hot water

INDEX

INTRODUCTION	1
Intended users of these instructions	1
Symbols	1
Applicable standards	1
Warnings	1
DESCRIPTION	2
Operating principle	2
Construction features	2
TECHNICAL SPECIFICATION	5
Maximum operating conditions	5
Burner chamber plate	5
Domestic hot water performances	5
General features	5
Dimensions	6
INSTALLATION	8
Boiler room	8
Chimney connections	8
Hot water connections	10
Heating connection	11
Oil supply connections	11
Electrical connections	12
Wiring diagram	12
COMMISSIONING	14
Filling the hot water and heating circuits	14
BURNER FEATURES	15
ACV BG 2000-S premix gas burners	15
ACV BM 101 and BM 151 oil burners	19
MAINTENANCE	20
Service intervals	20
Servicing the boiler	20
Servicing the safety devices	21
Servicing the burner	21
Draining the boiler	21
Spare parts	21
USER GUIDE	22
Using the boiler	22
Boiler safety shutdown	23
Resetting the oil burner	23
Resetting the BG 2000-S premix burner	23
Burner troubleshooting	23
SERVICE RECORD	24

INTRODUCTION

INTENDED USERS OF THESE INSTRUCTIONS

These instructions are intended for

- specifying engineers
- installing engineers
- end-users
- servicing engineers

SYMBOLS

The following symbols are used in these instructions:



Essential instruction for operating the system correctly.



Essential instruction for personal safety or environmental protection.



Danger of electrocution.



Risk of scalding.

APPLICABLE STANDARDS

The products have received the "CE" certificate in accordance with the standards prevailing in different countries (European Directives 92/42/EEC, "efficiency", 90/396/EEC "gas appliances"). These products have also received the Belgian "HR+" (gas boilers) marks and "OPTIMAZ" (oil boilers) marks.



WARNINGS

These instructions are an integral part of the equipment to which they refer and must be supplied to the user.

The product must be installed and serviced by qualified engineers, in compliance with the prevailing standards.

ACV accepts no liability for any damage resulting from incorrect installation or from the use of components or fittings not specified by ACV.



Failure to observe instructions regarding tests and test procedures can result in personal injury or pollution risks.

Note:

ACV reserves the right to modify the technical specifications and components of its products without prior notice.

DESCRIPTION

OPERATING PRINCIPLE

The HeatMaster is a high performance, direct fired hot water storage heater, which has indirect heat transfer due to its Tank-in-Tank construction.

At the heart of the HeatMaster is a stainless steel cylinder through which the flue tubes pass. This is surrounded by a mild steel shell containing the primary water (neutral fluid). The outer shell extends down to the combustion chamber and even around the flue tubes. The area of the heat transfer surface is therefore much greater than that of standard direct fired water heaters.

A circulating pump fitted to the primary circuit moves the water around the tank, heating it faster and maintaining an even temperature across the primary jacket.

The burner, either gas or oil, fires onto the primary water which indirectly heats the stainless steel cylinder containing the DHW. As with all Tank-in-Tanks, this is corrugated over its full height and suspended in the HeatMaster by its hot and cold water connections.

The cylinder expands and contracts during use and this, together with the fact that cold water does not come into contact with the intense heat of the burner flame, means that limescale buildup is prevented.

This scale resistant feature, along with the corrosion resistance of stainless steel, eliminates the need for sacrificial anodes.

The HeatMaster has one very major advantage over other direct fired water heaters - because it heats the DHW with a primary circuit, this primary water can be used to provide central heating as well.

By connecting two, three, four or more HeatMasters together in a module, most hot water and heating demands can be met.

Indeed, when used in conjunction with HR and Jumbo hot water storage tanks the Heatmaster can supply even the largest hot water requirement.

Standard equipment

The HeatMaster 60 N / 70 N / 100 N and 150 Jumbo has the following items as standard :

- On/off switch
- Summer/Winter switch
- Timeclock
- primary circulating shunt pump
- primary expansion vessels
- primary safety valve
- pressure and temperature gauge
- drain valve
- body completely insulated in rigid polyurethane foam

CONSTRUCTION FEATURES

Outer body

The outer body containing the primary fluid is made of thick STW 22 steel.

TANK-IN-TANK heat exchanger

The ring-shaped inner tank with its large heating surface for producing domestic hot water is built of Chrome/Nickel 18/10 stainless steel. It is corrugated over its full height by an exclusive production process and entirely argon arc welded by the TIG (Tungsten Inert Gas) method.

Combustion gas circuit

The combustion gas circuit is paint-protected and comprises:

- **Flue pipes**

Depending on output, HeatMaster models contain several steel flue pipes with an internal diameter of 64 mm. Each pipe is fitted with a baffle of special steel designed to improve heat exchange and reduce flue gas temperature.

- **Combustion chamber**

The combustion chamber on HeatMaster models is entirely water cooled.

Insulation

The boiler body is fully insulated by rigid polyurethane foam with a high thermal insulation coefficient, sprayed on without the use of CFCs.

Casing

The boiler is covered by a steel jacket which has been scoured and phosphated before being stove enamelled at 220 °C.

The jacket of the HM 150 Jumbo is delivered separately and must be assembled on site following the instructions supplied with it.

Burner

All HeatMaster models can be fitted with pressure jet gas burners or oil burners. The HeatMaster 60, 70 and 100 can also be fitted with the low-NOx pre-mix BG 2000 gas burner.

DESCRIPTION

Features of HeatMaster 70 N / 100 N

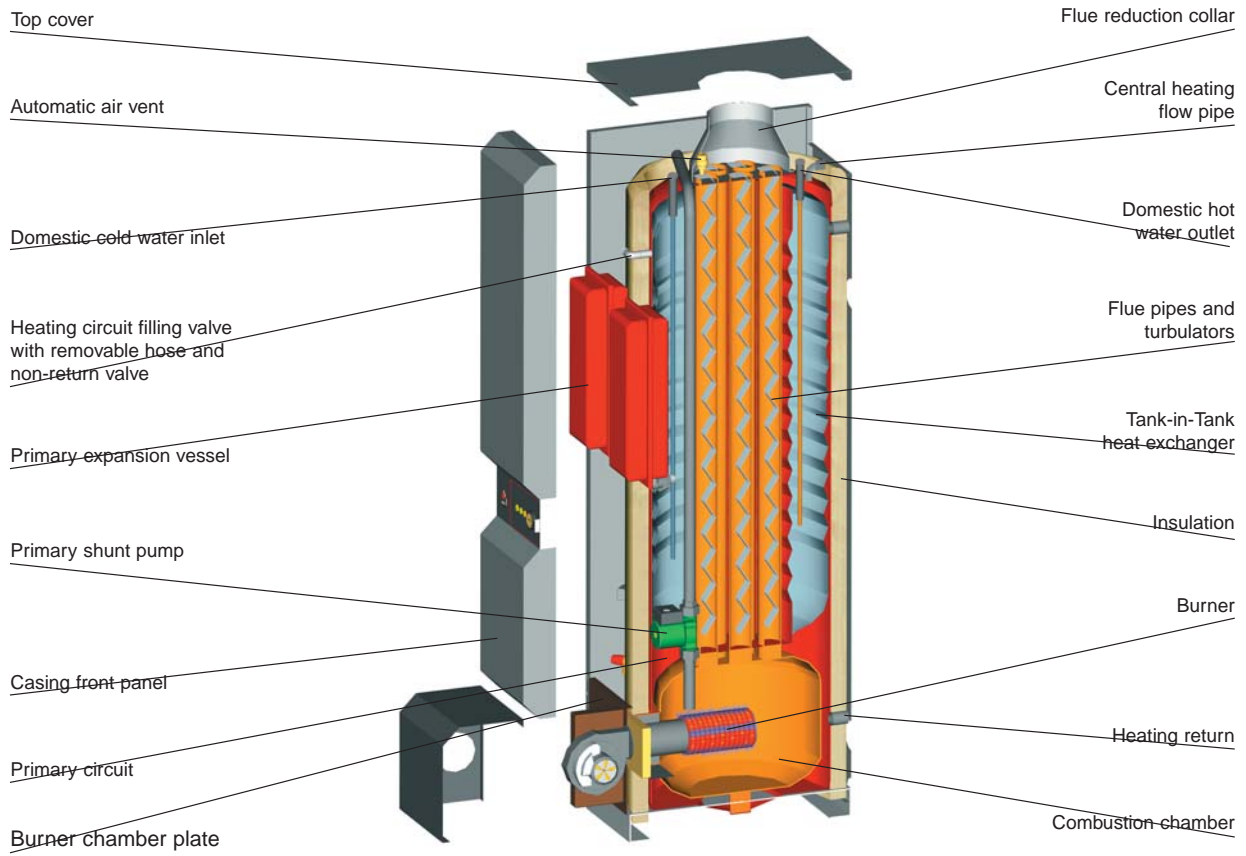

Safety features of the HeatMaster 60 N

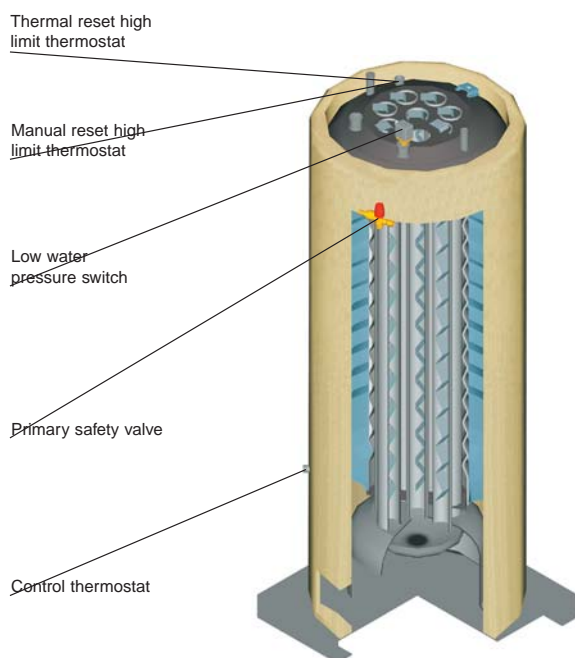

Control panel HeatMaster 60 N

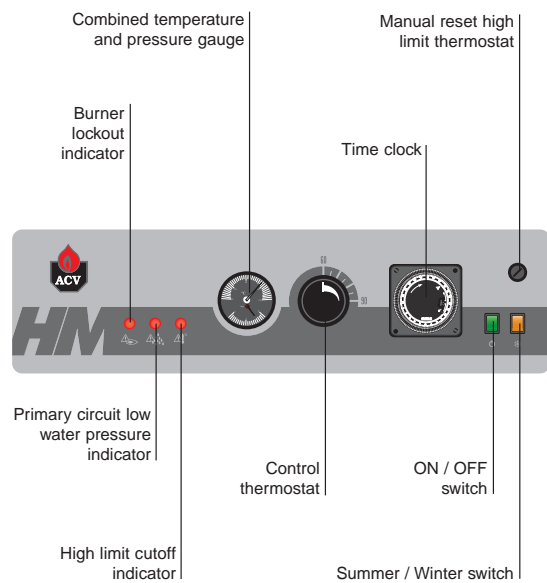

DESCRIPTION

Safety features of the HeatMaster 70 N and 100 N

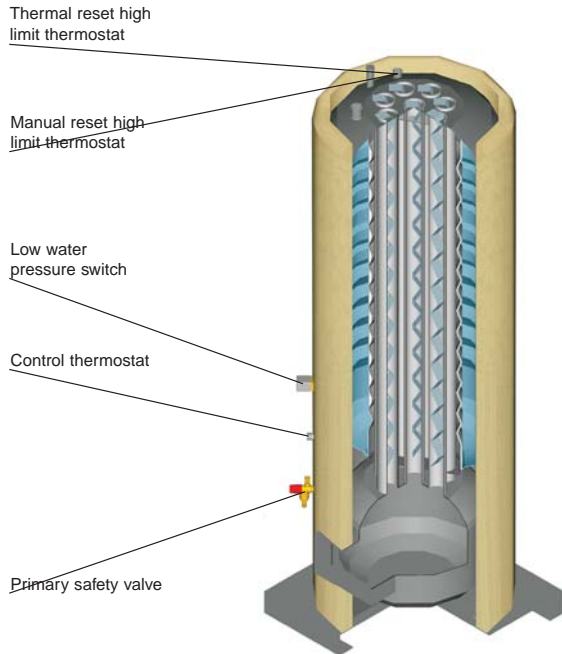

Control panel HeatMaster 70 N and HeatMaster 100 N

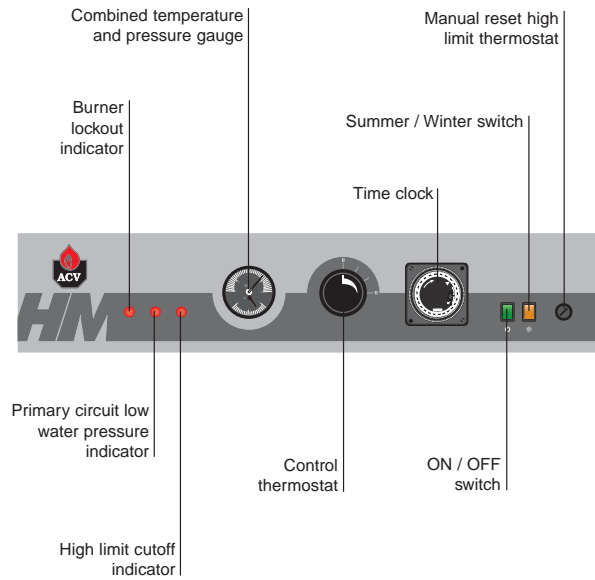

Safety features of the HeatMaster 150 Jumbo

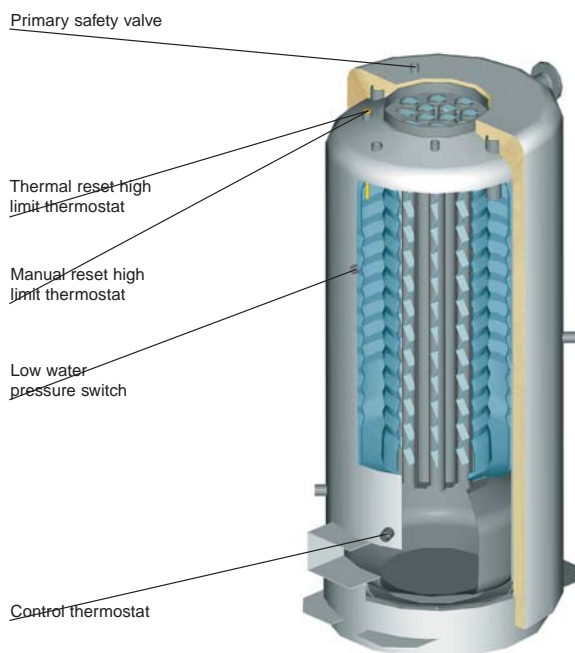

Control panel HeatMaster 150 Jumbo

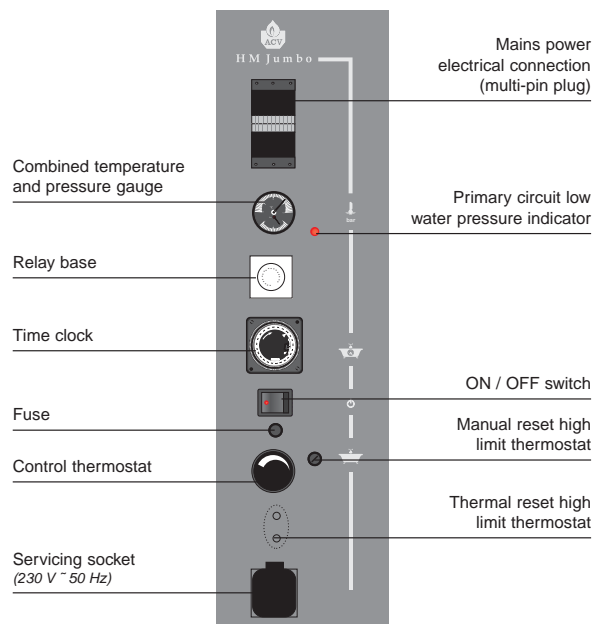

TECHNICAL SPECIFICATION

MAXIMUM OPERATING CONDITIONS

Maximum service pressure (tank full of water)

- Primary circuit: 3 bar
- Secondary circuit: 10 bar

Test pressure (tank full of water)

- Primary circuit: 4.5 bar
- Secondary circuit: 13 bar

Operating temperature

- Maximum temperature: 90 °C

Water quality

- Chlorures: < 150 mg/l (304)
< 2000 mg/l (Duplex)
- $6 \leq \text{ph} \leq 8$

BURNER CHAMBER PLATE

The burner chamber plate has 4 threads (M 10 x 20) for attaching the burner. It is protected from heat by a blanket insulation.

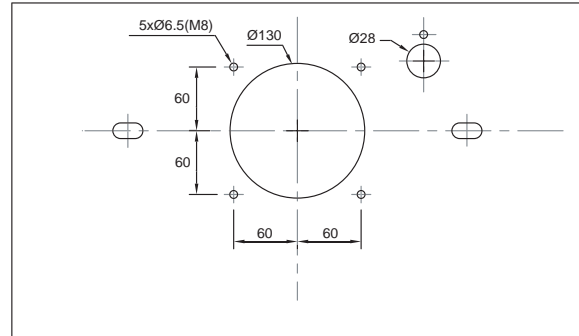

DOMESTIC HOT WATER PERFORMANCES

		HM 60 N BM 101	HM 60 N BG 2000-S/60	HM 70 N BM 101	HM 70 N BG 2000-S/70	HM 100 N BM 101	HM 100 N BG 2000-S/100	HM 150 JUMBO
Peak delivery at 40 °C	L/10'	474	474	646	646	905	905	1504
Peak delivery at 45 °C	L/10'	378	378	543	543	777	777	1289
Peak delivery at 60 °C	L/10'	245	245	346	346	514	514	870
Peak delivery at 70 °C	L/10'	193	193	268	268	343	343	700
Peak delivery at 80 °C	L/10'	135	135	207	207	258	258	540
Peak delivery at 40 °C	L/60'	1942	1942	2133	2133	3172	3172	4828
Peak delivery at 45 °C	L/60'	1656	1656	1794	1794	2680	2680	4138
Peak delivery at 60 °C	L/60'	1106	1106	1219	1219	1813	1813	2864
Peak delivery at 70 °C	L/60'	681	681	971	971	1226	1226	2131
Peak delivery at 80 °C	L/60'	499	499	636	636	893	893	1362
Continuous delivery at 40 °C	L/h	1835	1835	1835	1835	2776	2776	3989
Continuous delivery at 45 °C	L/h	1573	1573	1573	1573	2379	2379	3419
Continuous delivery at 60 °C	L/h	1101	1101	1067	1067	1665	1665	2393
Continuous delivery at 70 °C	L/h	791	791	918	918	1104	1104	1718
Continuous delivery at 80 °C	L/h	455	455	580	580	804	804	987
Reheat time at 60 °C	min	9	9	16	16	13	13	17

GENERAL FEATURES

		HM 60 N	HM 70 N	HM 100 N	HM 150 JUMBO
Maximum Input	kW	69.9	69.9	107.0	154.0
Maximum Output	kW	62.5	63.0	96.8	139.1
Maintenance loss at 60 °C as rated value	%	0.57	0.60	0.65	0.52
Total capacity	L	162	239	330	645
Primary circuit capacity	L	82	108	130	245
Heating connection	Ø	1 1/2"	1 1/2"	1 1/2"	DN 50
Hot water connection	Ø	3/4"	1"	1"	2"
Hot water tank heat exchange surface	m ²	2.46	3.14	3.95	5.30
Weight empty	Kg	220	270	320	530
Pressure drop primary circuit	mbar	54	46	83	120

TECHNICAL SPECIFICATION

DIMENSIONS

The units are delivered fully assembled, tested and packed on a timber base with shockproof edges and protected by heat-shrunk plastic film. On reception and after unpacking, check the equipment for damage. For transport purposes, refer to the weight (page 5) and dimensions given below.

	A mm	B mm	C mm	D mm	E mm	F mm	G Ø mm	H mm	J mm	K mm
HM 60 N	1698	1583	538	625	540	390	150	1098	281	1665
HM 60 N BG 2000-S 60	1698	1583	538	801	540	390	150	1098	281	1665
HM 70	1743	1630	678	797	680	390	150	1289	285	1720
HM 70 N BG 2000-S 70	1743	1630	680	937	680	390	150	1289	285	1720
HM 100 N	2093	2030	680	797	680	390	150	1693	285	2120
HM 100 N BG 2000-S 100	2093	2030	680	937	680	390	150	1693	285	2120
HM 150 Jumbo	2124	2117	1020	1440	1020	600	250	1383	590	2250

HeatMaster 60 N

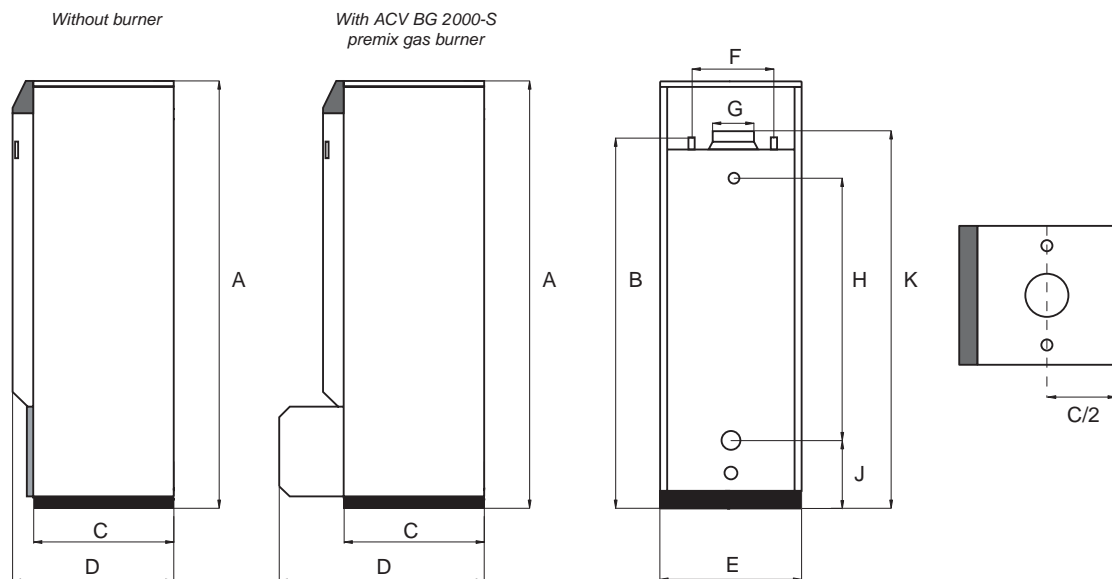

TECHNICAL SPECIFICATION

HeatMaster 70 N and HeatMaster 100 N

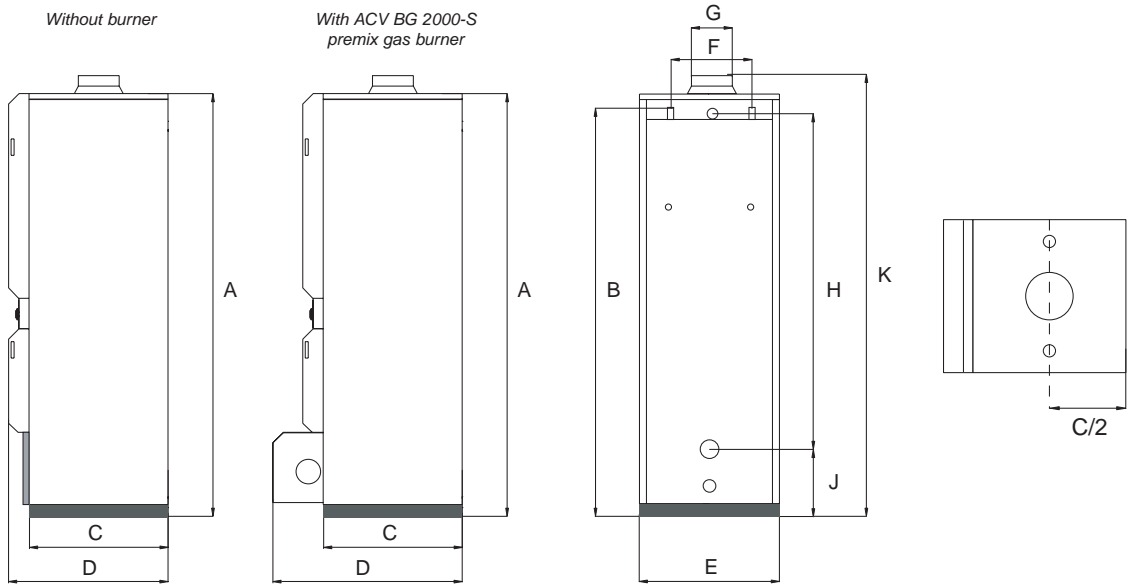

HeatMaster 150 Jumbo

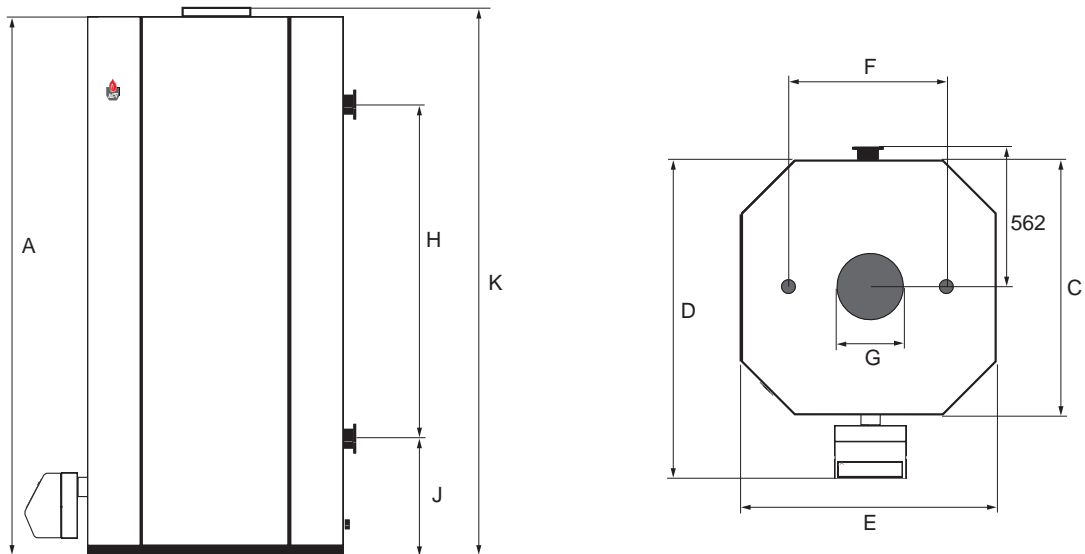

INSTALLATION

BOILER ROOM

Important

- Keep vents free at all times.
- Do not store inflammable products in the boiler room.
- Do not store corrosive products near the boiler, such as paints, solvents, chlorine, salt, soap and other cleaning products.
- If you smell gas, do not switch on the light or light a flame. Turn off the mains gas tap at the meter and inform the appropriate services immediately.

Access

The boiler room must be large enough to allow good access to the boiler. The following minimum distances are required around the boiler:

- front 500 mm
- side 100 mm
- behind 150 mm
- above 700 mm

Ventilation

The boiler room must be fitted with top and bottom vents sized according to the table below or to current regulations.

The table below gives an example conforming to the Belgian standards.

Ventilation		60 N	70 N	100 N	150 Jumbo
Min. fresh air requirement	m³/h	126	126	194	278
Bottom	dm²	2.11	2.11	3.20	4.8
Top	dm²	2.0	2.0	2.0	2.0

Other countries should refer to their own standards.

Base

The base on which the boiler rests must be made of non-combustible materials.

CHIMNEY CONNECTIONS



IMPORTANT

Boilers must be installed by an approved heating engineer, in accordance with the prevailing local standards and regulations.



Flue size should not be less than the outlet size of the boiler.

Chimney connection type: B23

The boiler is connected to the chimney by a metal pipe rising at an angle from the boiler to the chimney.

A flue disconnection piece is required.

This must be easy to remove to give access to the flue pipes when servicing the boiler.

- A. Top vent
- B. Bottom vent
- C. Draught regulator
- D. Inspection window
- E. Height of lined chimney
- F. Chimney diameter

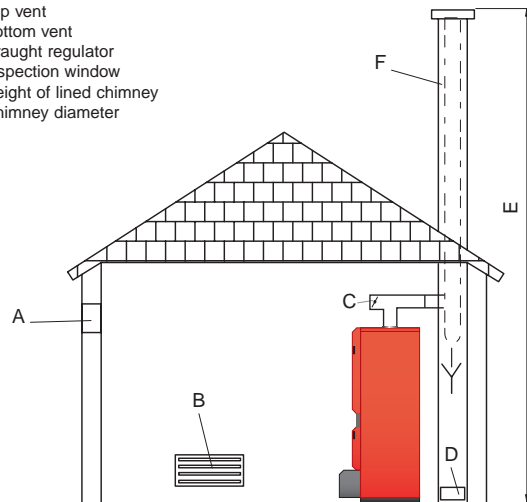

Chimney minimum flue diameter	60 N	70 N	100 N	150 Jumbo
E = 5 m Ø F min. mm	189	189	234	286
E = 10 m Ø F min. mm	159	159	178	250
E = 15 m Ø F min. mm	150	150	150	250



Note:

Regulations vary from country to country therefore the table above is intended only as a guide.



Due to the high efficiency of our boilers, the flue gasses exit at low temperature. Accordingly, there is risk that the flue gasses could condense, which could damage the chimney. In order to avoid this risk, it is strongly recommended that the chimney be lined.

Balanced flue boiler connection type: C

- C13: concentric horizontal connection
- C33: concentric vertical connection
- C53: parallel chimney connection
- C63: concentric vertical connection without terminal (only in Germany and Luxembourg).

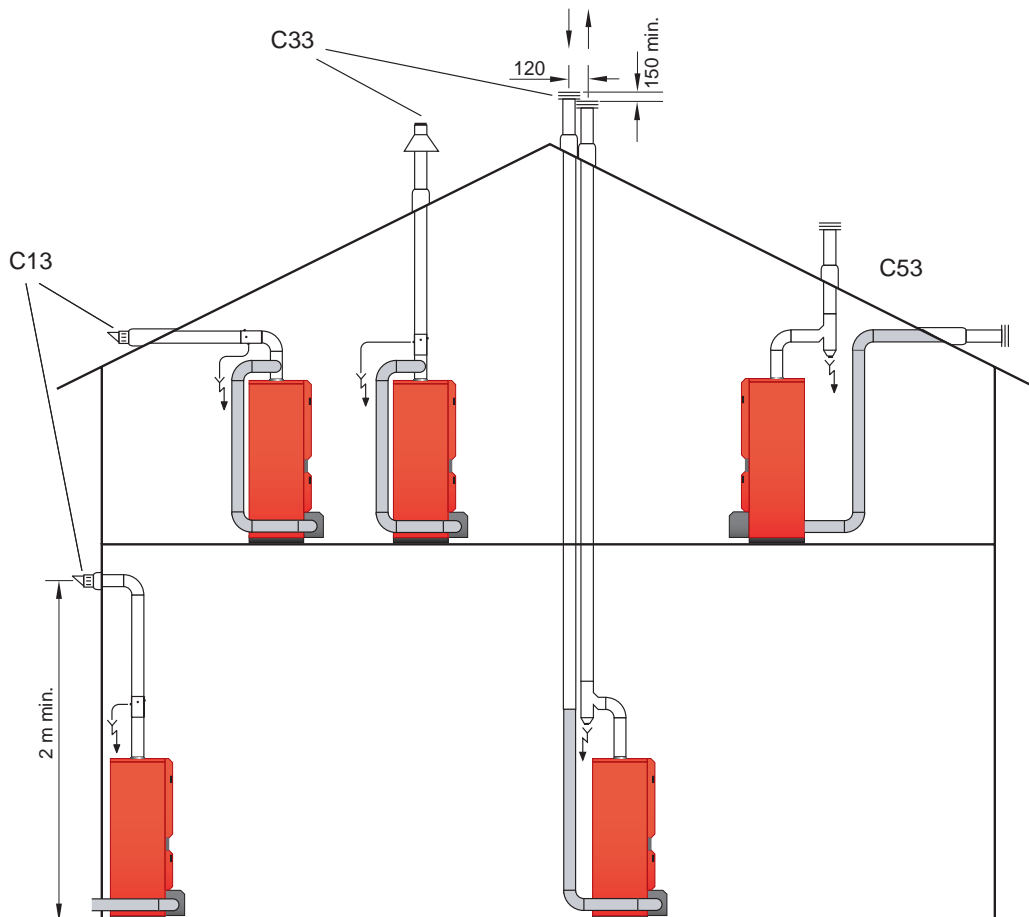

Maximum length concentric : 6 metres

Maximum length parallel : 12 metres

Note: a 90 degree bend = 1 metre equivalent length



A condensation drain outlet must be fitted close to the boiler to prevent condensation products from the chimney running into the boiler.



To avoid condensation water running out of the terminal, all horizontal flue runs must fall back towards the boiler.

INSTALLATION

HOT WATER CONNECTIONS

Pressure reducing valve

If the mains water pressure is greater than 6 bar, a pressure reducing valve must be fitted.

Expansion relief valve

The tank expansion relief valve must be ACV approved and calibrated to a maximum of 7 bar. The valve discharge must be connected to the drain.

Hot water expansion vessel

A hot water expansion vessel must be installed.

Hot water circulation

If the tank is situated a long way from the point of use, then installing a recirculation loop can provide a faster supply of hot water to the outlets.

Temperature and pressure relief valve

If using the HeatMaster as an unvented hot water unit, in some countries, a temperature and pressure relief valve must be fitted - consult your ACV stockist for assistance.

Example of hot water connection with thermostatic mixer

1. Stop cock
2. Non-return valve
3. Pressure reducing valve
4. Expansion relief valve
5. Hot water expansion vessel
6. Hot water secondary pump (if fitted)
7. Thermostatic mixing valve
8. Drawoff tap
9. Drain cock
10. Stop cock for cleaning
11. Temperature relief valve (UK-only)

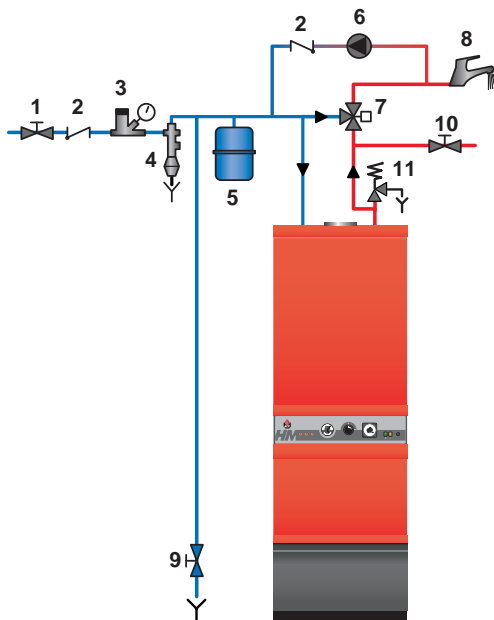

DANGER!
As a safety measure against scalding, we strongly recommend installing a thermostatic mixing valve.

Example of parallel connection

Recommended for applications with a high continuous flow.

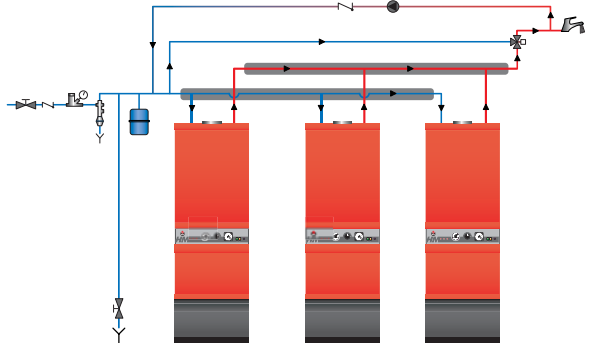

Example of series connection

Preferable for high temperature applications with up to three units.

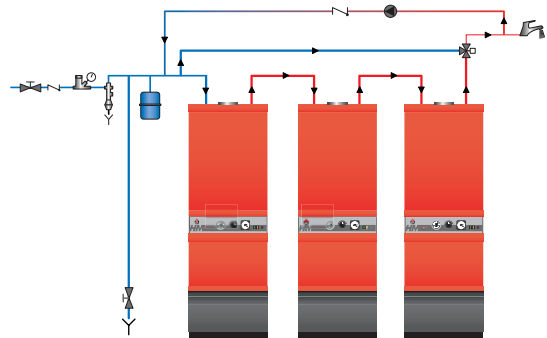

Example of heating + storage connection

Recommended for applications requiring a high peak flow.

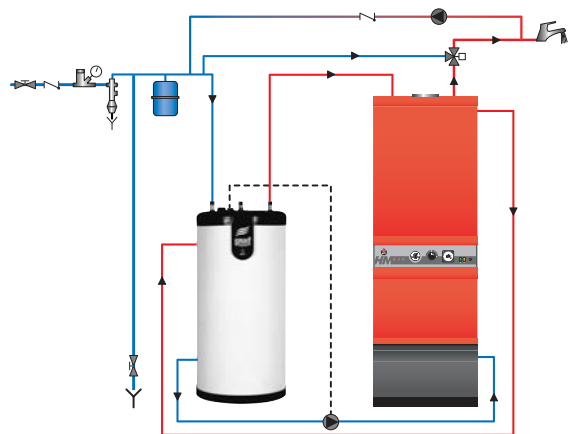

HEATING CONNECTION

The HeatMaster has two connections at the rear that can be used to connect a central heating circuit. Connecting a heating system may reduce the domestic hot water performance.

Expansion

The HM 60 is fitted with an 8 litre expansion vessel. HM 70/100 models are fitted with two 10 litre expansion vessels, and the HM 150 Jumbo is fitted with four 8 litre expansion vessels. These expansion vessels are sized for hot water operation only. If a heating system is connected to the primary circuit, calculate the expansion capacity necessary for the total volume of the heating system. (Refer to the technical instructions from a relevant manufacturer of expansion vessels).

Example of a single circuit connection

1. 3-way valve
2. Heating pump
3. Non-return valve
4. Isolating valves
5. Safety valve set to 3 bar with pressure gauge
6. Expansion vessel
7. Drain cock
8. Controller

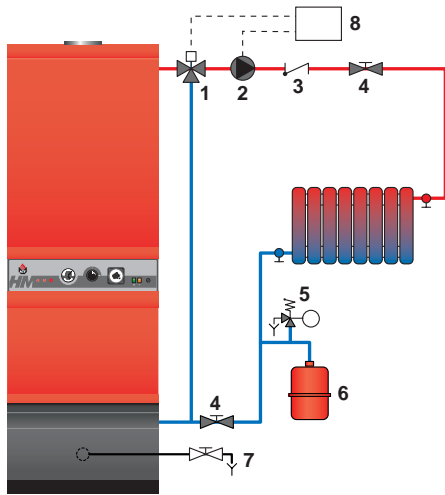

WARNING

The primary safety valve is supplied with a plastic tube connected to the discharge outlet - this is for test purposes only and should be removed. The safety valve should be connected to a drain using a metallic pipe eg. copper.

OIL SUPPLY CONNECTIONS - ACV BM BURNERS

(If another make of burner is fitted please refer to that manufacturer's technical manual)

Installation without return

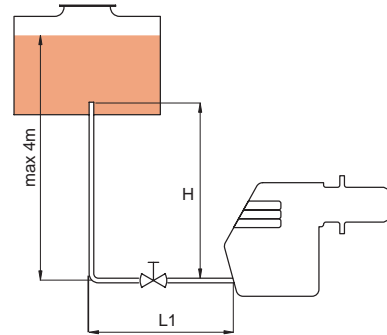

	L (m) (L = H + L1)	
H (m)	Ø int. 8 mm	Ø int. 10 mm
0.5	10	20
1	20	40
1.5	40	80
2	60	100

Installation with return

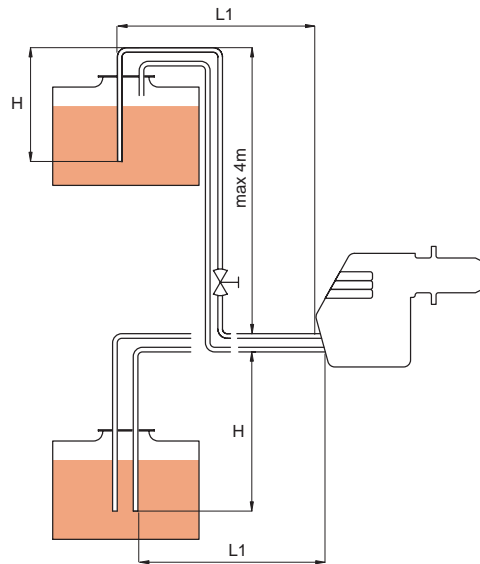

	L (m) (L = H + L1)	
H (m)	Ø int. 8 mm	Ø int. 10 mm
0	35	100
0.5	30	100
1	25	100
1.5	20	90
2	15	70
2	8	30
3.5	6	20

INSTALLATION

ELECTRICAL CONNECTIONS

Power supply

The boiler operates with a 230 V - 50 Hz single phase supply. A double pole isolator with a 6 amp fuse or a 6 amp MCB must be fitted outside the boiler to allow power to be shut off during servicing and before any repairs are carried out on the boiler.

Conformity

Boiler installation must comply with the prevailing local standards and legislation.

Safety

The stainless steel tank must be earthed separately.



The power to the boiler must be switched off before any work is carried out.

WIRING DIAGRAM

HeatMaster wiring diagram legend

60 N, 70 N, 100 N (page 13) and 150 Jumbo (page 14)

1. 230 V power connection plug
2. On/off switch
3. Temperature high limit cutoff indicator (except HM 150 Jumbo)
4. Manual reset high limit thermostat
5. Primary circuit low water pressure indicator
6. Low water pressure switch
7. Time clock
8. Summer/winter switch (except HM 150 Jumbo)
9. Hot water priority link (except HM 150 Jumbo)
10. Burner lockout indicator (except HM 150 Jumbo)
11. Room thermostat connection (option)
12. Central heating pump
13. HeatMaster shunt pump
14. Burner plug connector
15. Water flow switch connection (option)
16. Thermal reset high limit thermostat 95 °C
17. Control thermostat
18. 230 V servicing socket (only HM 150 Jumbo)
19. Relay (only HM 150 Jumbo)

Electrical connection HeatMaster 60 N, 70 N and 100 N

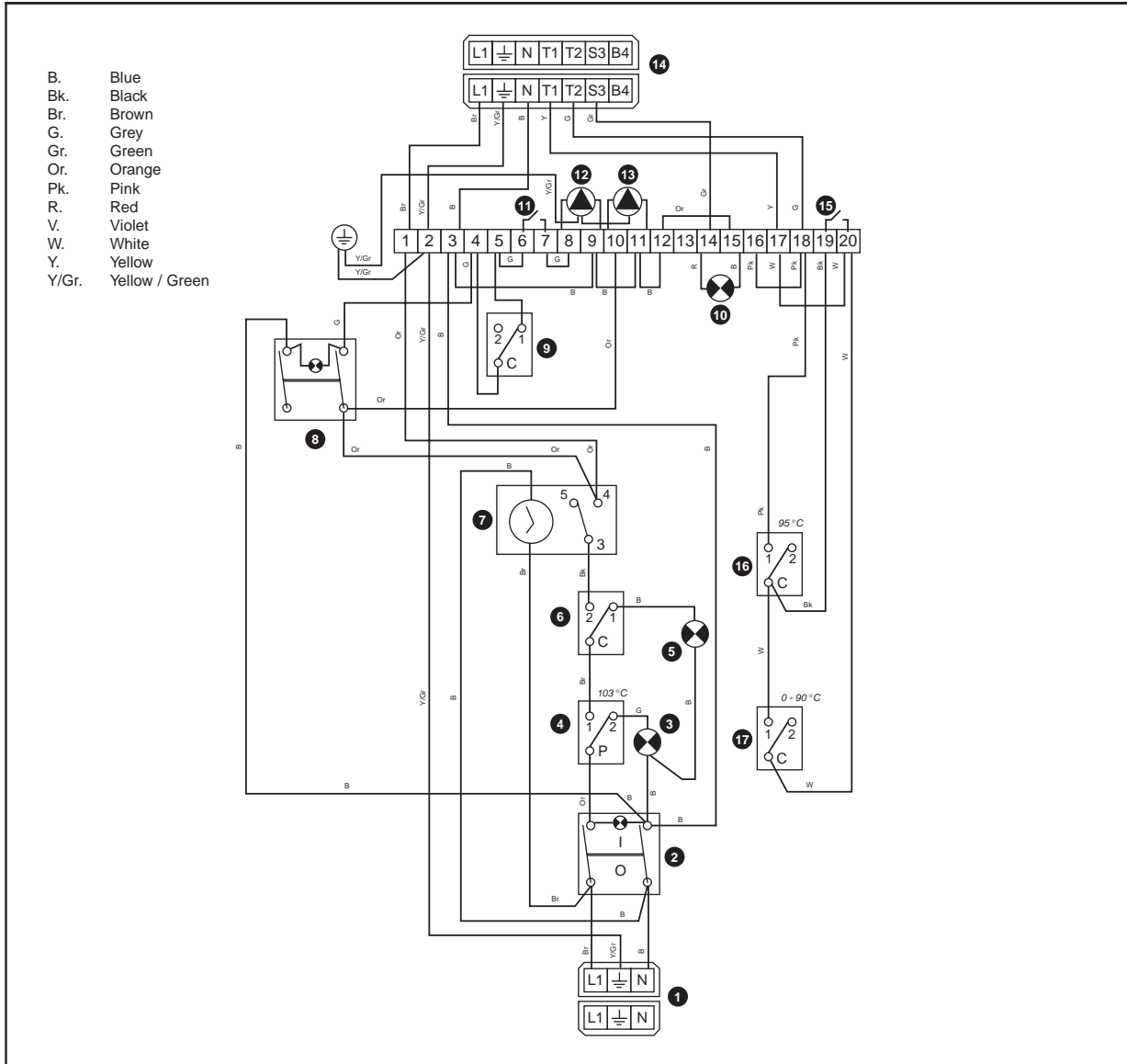

Electrical connection HeatMaster 150 Jumbo

B.	Blue	Pk.	Pink
Bk.	Black	R.	Red
Br.	Brown	V.	Violet
G.	Grey	W.	White
Gr.	Green	Y.	Yellow
Or.	Orange	Y/Gr.	Yellow / Green

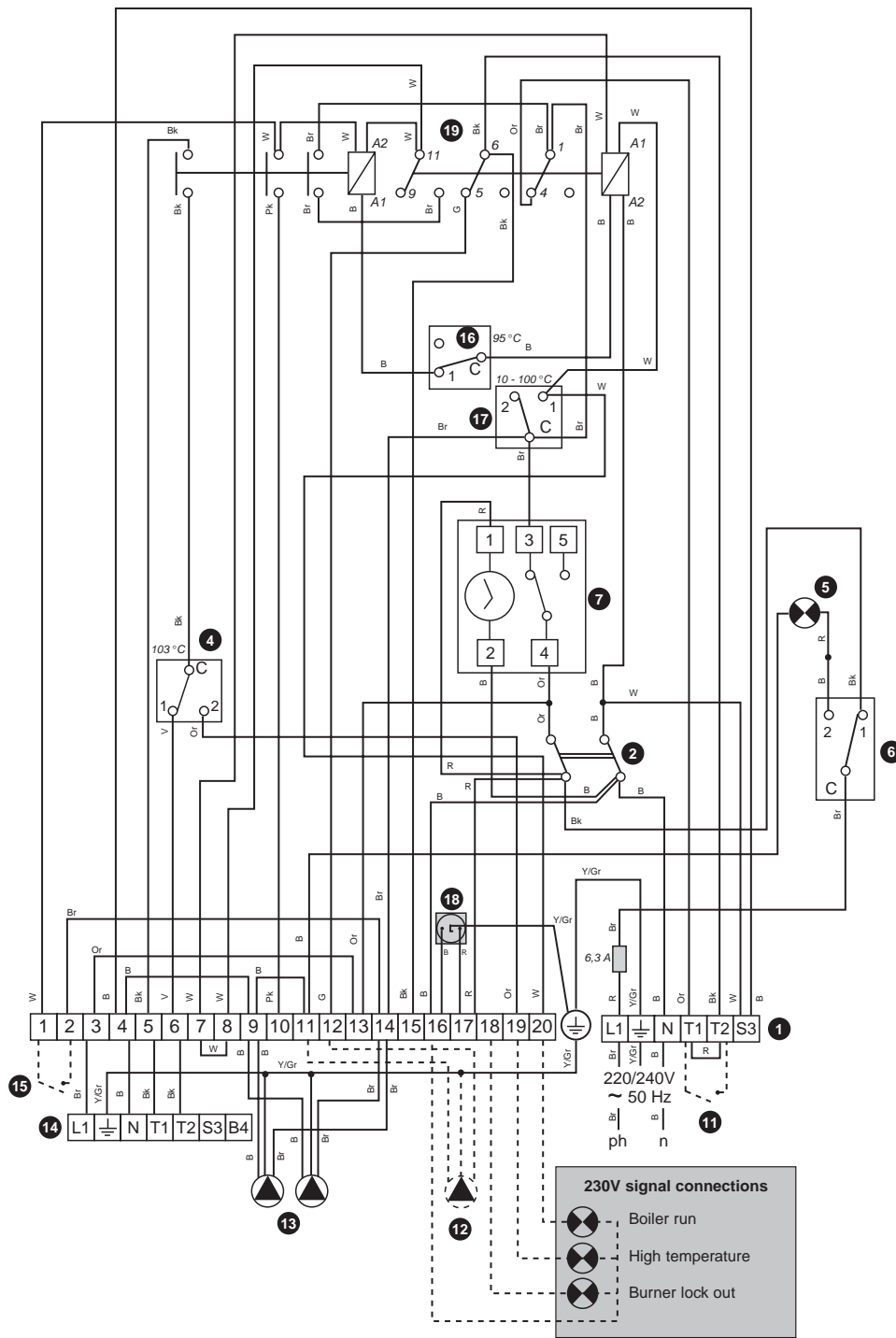

COMMISSIONING

FILLING THE HOT WATER AND HEATING CIRCUITS



IMPORTANT
Hot water tank must be pressurised before the heating circuit is filled.

1. Close the primary circuit filling valves (A)
2. Open the stop valve (B) and the drawoff tap (C).
When water flows out of the tap, the hot water tank is full and the drawoff tap (C) should be closed.
3. Fill the primary (heating) circuit by opening the valves (A) and pressurising to 1 bar.
4. Open the automatic air vent located on top of the boiler.
IMPORTANT - the screw cap must be left loose to allow future automatic venting to take place.
5. After venting the air from the system, bring the pressure up to the static head plus 0.5 bar: 1.5 bar = 10m and 2 bar = 15 m.
6. Check that the electrical connection and boiler room ventilation conform to the relevant standards.
7. Set the thermostat between 60 and 90 °C.
8. Switch the on/off switch to the ON position.
9. For gas burner, check the gas supply pressure on starting up.
10. For the oil burner, check the oil supply (and return). Proceed with the necessary venting, measurements and settings.
11. Set the heating control to heat demand. When the burner operates, check the flue gas discharge pipes for leaks.
12. After 5 minutes of operation, vent the primary circuit again maintaining the water pressure at 1 bar.
13. Then restart the unit and check the combustion.

HeatMaster 70 N and 100 N

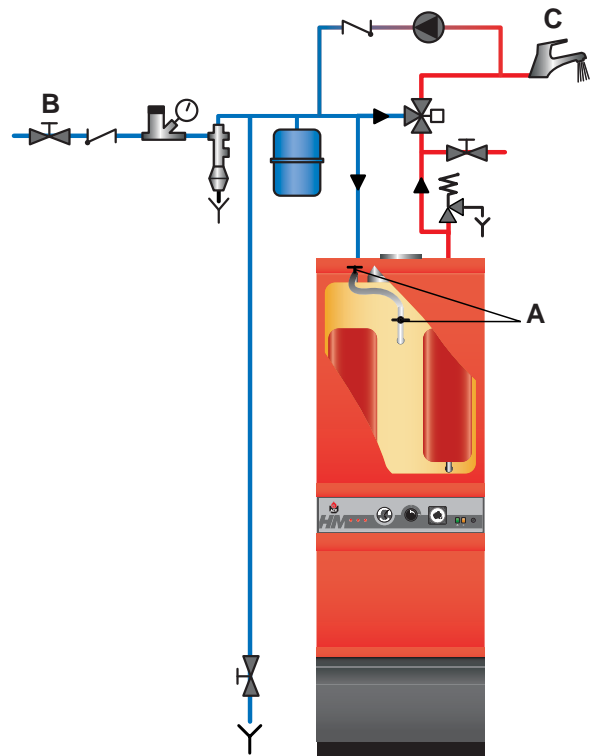

HeatMaster 60 N

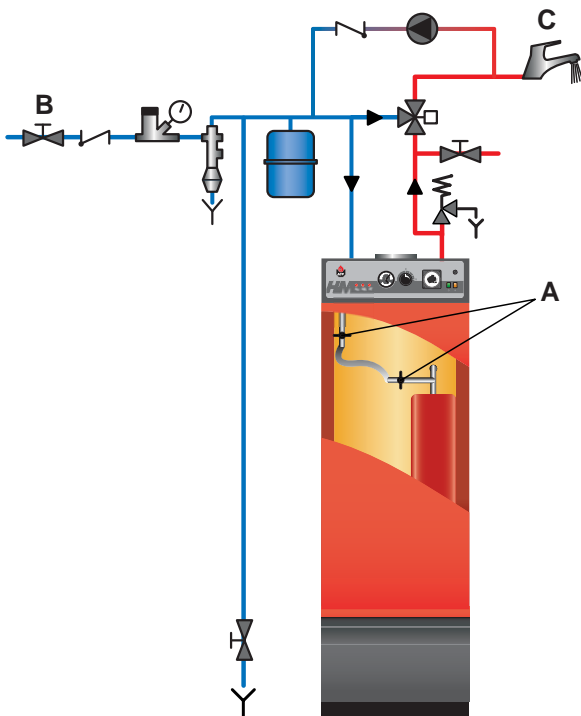

HeatMaster 150 Jumbo

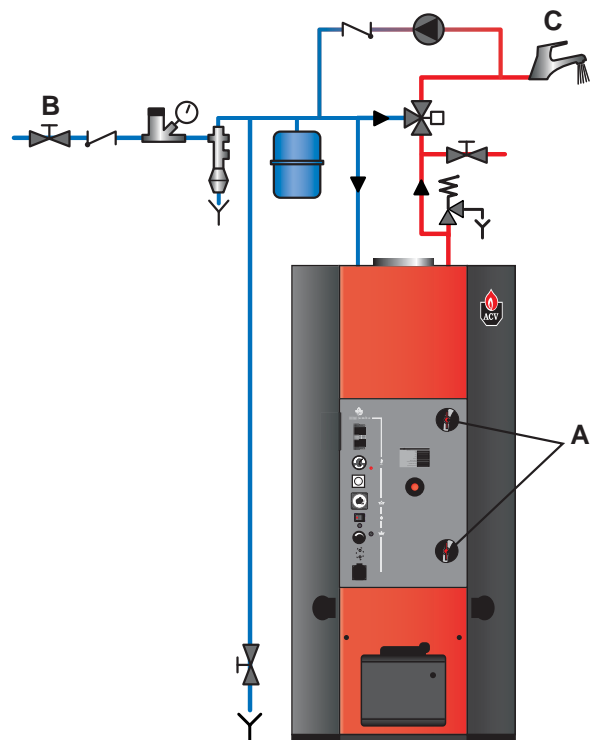

ACV BG 2000-S PREMIX GAS BURNERS

Description

The burner tube is coated with metal fibre (NIT) which, in addition to its remarkable heat exchange capabilities, gives greater durability.

The main components are a venturi and one (model 60 and 70) or two (model 100) gas valves, technology specially developed by Honeywell for low Nox premix air/gas burners with automatic ignition and ionisation flame detection.

The pressure at the gas valve outlet is equal to the air pressure in the neck of the venturi, less the offset. The fan sucks combustion air through the venturi, into which the gas inlet emerges.

As it passes through, the air produces a pressure differential in the constriction of the venturi and sucks the gas into the venturi outlet. A perfect mix of air and gas then passes through the fan to the burner tube.

This design ensures very quiet and safe operation:

- If there is an air blockage, the pressure differential in the venturi falls, the gas flow diminishes, the flame goes out and the gas valve closes: the burner is in safety shutdown mode.
- If there is a blockage in the chimney outlet, the air flow diminishes, and the same reactions as those described above cause the burner to shut down in safety mode.
- The BG 2000-S burner fitted to the HeatMaster 60, 70 and 100 is controlled by a Honeywell module which controls burner operating safety.

ACV BG 2000-S premix gas burners dimensions

Type	A	B	C
BG 2000-S / 60	375	228	248
BG 2000-S / 70	375	248	342
BG 2000-S / 100	375	248	342

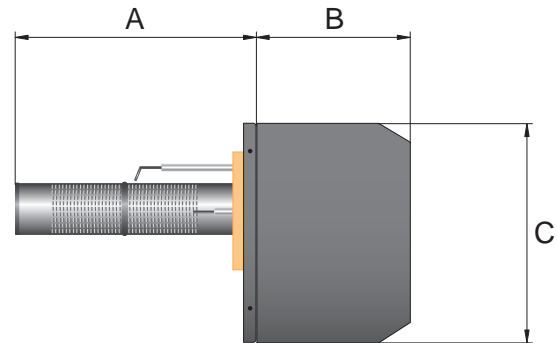

BG 2000-S burners are preset at the factory for natural gas.

Conversion to propane:



Not applicable for Belgium.

Conversion kit included with burner comprising:

- Cap(s)
- Nameplate(s)
- Sticker with settings.
- Mounting instructions.

Air-gas mixture control system

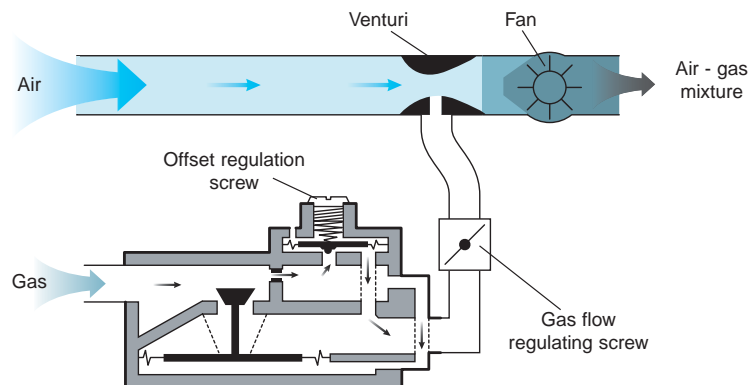

BURNER FEATURES

Burner electrical connection BG 2000-S/60 and BG 2000-S/70

Electrical connections

- B. Blue
- Bk. Black
- Br. Brown
- G. Grey
- Gr. Green
- Y. Yellow
- Y/Gr. Yellow / Green

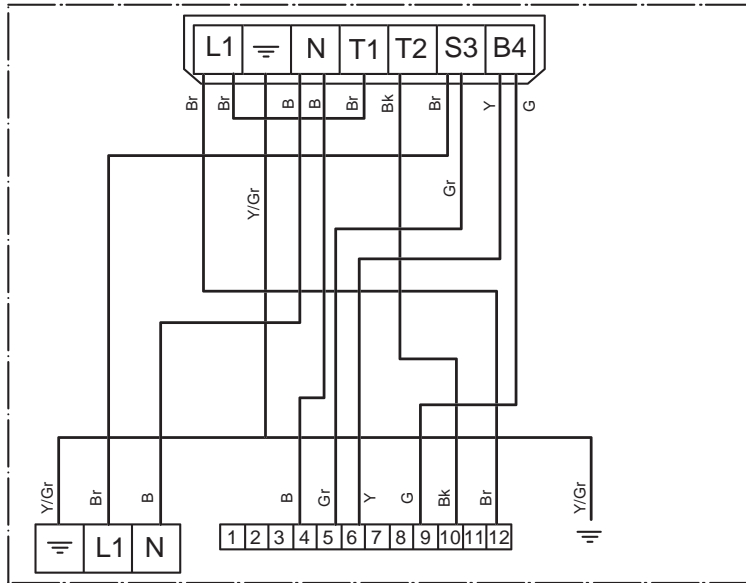

Burner electrical connection BG 2000-S/100

Electrical connections

- B. Blue
- Bk. Black
- Br. Brown
- G. Grey
- Gr. Green
- Y. Yellow
- Y/Gr. Yellow / Green

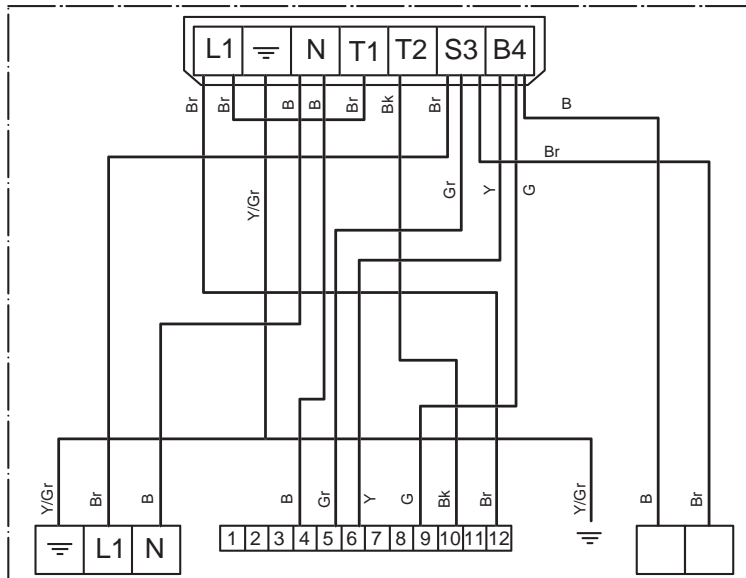

BURNER FEATURES

ACV premix gas burner BG 2000-S/60 and BG 2000-S/70

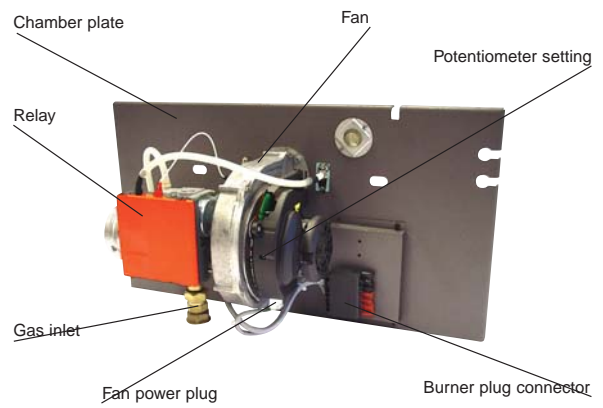
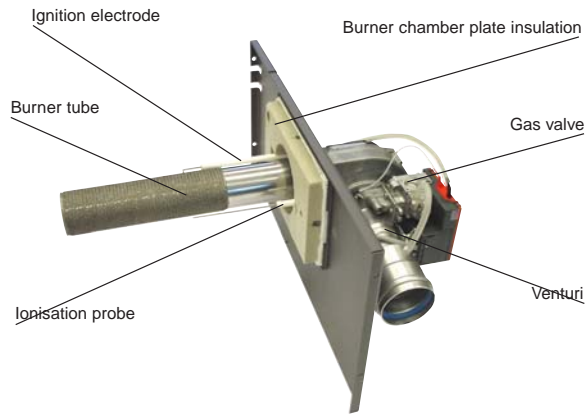

ACV premix gas burner BG 2000-S/100

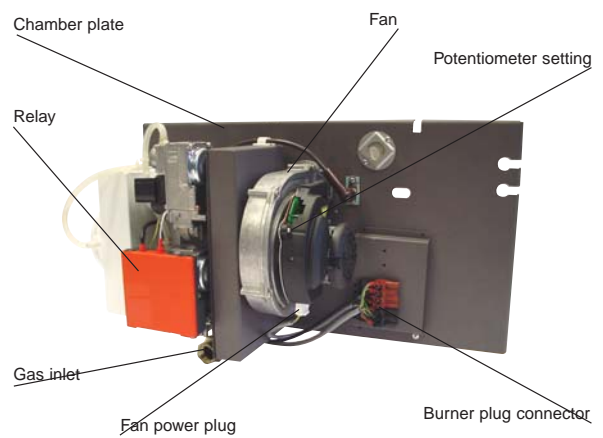
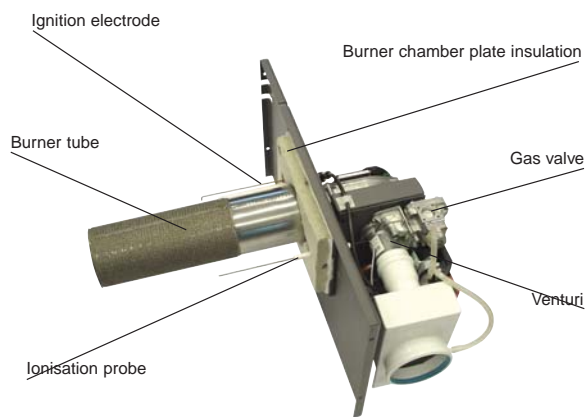

BURNER FEATURES

HeatMaster 60, 70 and 100 Gas burner features - BG 2000

		HM 60 N + BG 2000-S/60	HM 70 N + BG 2000-S/70	HM 100 N + BG 2000-S/100	HM 100 N + gas pressure jet burner	HM 150 Jumbo + gas pressure jet burner
Input	kW	69.9	69.9	85.0	96.8	154
Output	kW	63.0	63.0	77.4	90.0	139.1
Combustion efficiency - natural gas	%	91.2	91.5	92.9	92.9	91.5
Natural gas CO ₂	%	9.5	9.0	9.0	9.0	9.0
Gas G20 - 20 mbar - I 2E(S)B - I 2 Er - I 2H						
Flow	m³/h	7.40	7.40	8.99	10.24	16.30
Gas G25 - 20/25 mbar - I 2L - I 2ELL						
Flow	m³/h	8.60	8.60	10.46	11.91	18.95
Gas G31 - 37/50 mbar - I 3P						
Flow	m³/h	2.86	2.86	3.47	3.95	6.29
Pressure drop combustion chamber	mbar	0.6	0.6	1.4	1.4	0.6
Flue gas temperature (net)	°C	186	172	145	165	181
Mass rate of combustion products (<i>grammes per second</i>)		32.1	32.1	39.1	44.5	70.8

Gas category

	BE	FR	AT	DK	ES	UK	IT	PT	IE	SE	NL	LU	DE
I 2Er	•												
I 2E(S)B	•												
I 2H			•	•	•	•	•	•	•	•			
I 3P	•	•			•	•		•	•				
I 2L											•		
I 2ELL												•	•

BURNER FEATURES

ACV BM 101 AND BM 151 OIL BURNERS

Description

The use of new technology enables our medium output burners to meet current performance and emissions quality requirements. These burners are fitted with high quality components including a two-stage oil pump that permits soft start.

Components:

- Landis & Gyr relay
- A.E.G. motor
- Suntec pump
- May & Christe transformer
- Landis & Gyr oil preheater

Features

- Easy to install – fitted with safety closure and new burner suspension system.
- The burner air pressure adjusts to the pressure in the burner chamber.
- An automatic damper shuts off the air flow when the burner is turned off, preventing the boiler from cooling.
- Quiet and extremely reliable.
- Adjustable to the depth of the boiler burner chamber thanks to the adjustable bracket at the mouth of the burner chamber.
- Three air adjustment points to ensure the best air/oil mixture.
 - upstream air presetting
 - primary setting
 - combustion head setting

Oil burner specification and performances

		HM 60 N	HM 70 N	HM 100 N	HM 150 JUMBO
Burner type		BM 101	BM 101	BM 151	BM 151
Input	kW	69.9	69.9	107.0	154.0
Nozzle flow	US Gal/h	1.50	1.50	2.00	3.00
Nozzle angle		60°	60°	60°	60°
Oil flow	Kg/h	5.9	5.9	8.92	13.0
Pump pressure	bar	10.5	10.5	13.5	12.5
Pressure drop combustion chamber	mbar	0.6	0.6	1.4	0.6
Flue gas temperature (net)	°C	175	170	170	181
CO ₂	%	12.5	12.5	12.5	12.5
Mass rate combustion products (<i>grammes per second</i>)		29.6	29.6	44.8	64.7

BM oil burners dimensions

	A mm	B mm	C mm	D mm	E mm	F mm	G Ø	L Ø	LK Ø	Kg
BM 101	260	300	250	310	60 - 150	M 8	90	95	125 - 180	14
BM 151	280	340	280	350	60 - 190	M 8	115	120	156 - 200	20

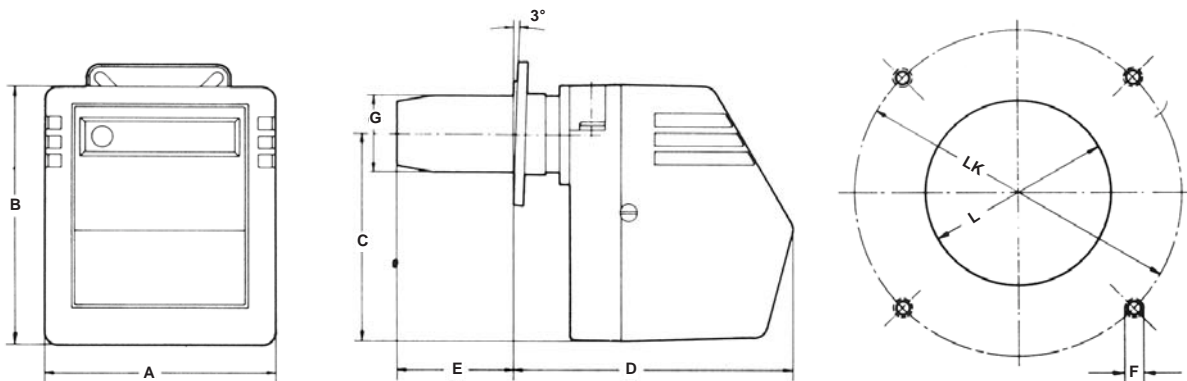

MAINTENANCE

SERVICE INTERVALS

ACV recommends that boilers should be serviced at least once a year. The burner must be serviced and tested by a competent engineer. If a boiler is subject to heavy use, it may require servicing more than once a year - consult ACV for advice.

SERVICING THE BOILER

1. Turn OFF the on/off switch on the boiler control panel and isolate external electrical supply.
2. Turn off the gas or oil supply to the boiler.
3. Remove the flue to gain access to the top of the boiler.
4. Remove the casing top panel and lift off the flue reduction collar by undoing the fastening bolts.
5. Remove the turbulators from the flue pipes for cleaning.
6. Unscrew the burner chamber plate and remove the burner.
7. Brush the flue pipes .
8. Clean the burner chamber and the burner.
9. Re-assemble turbulators, flue reduction collar and flue, checking that the gasket on the flue reduction collar is in good condition. Replace gasket if necessary.

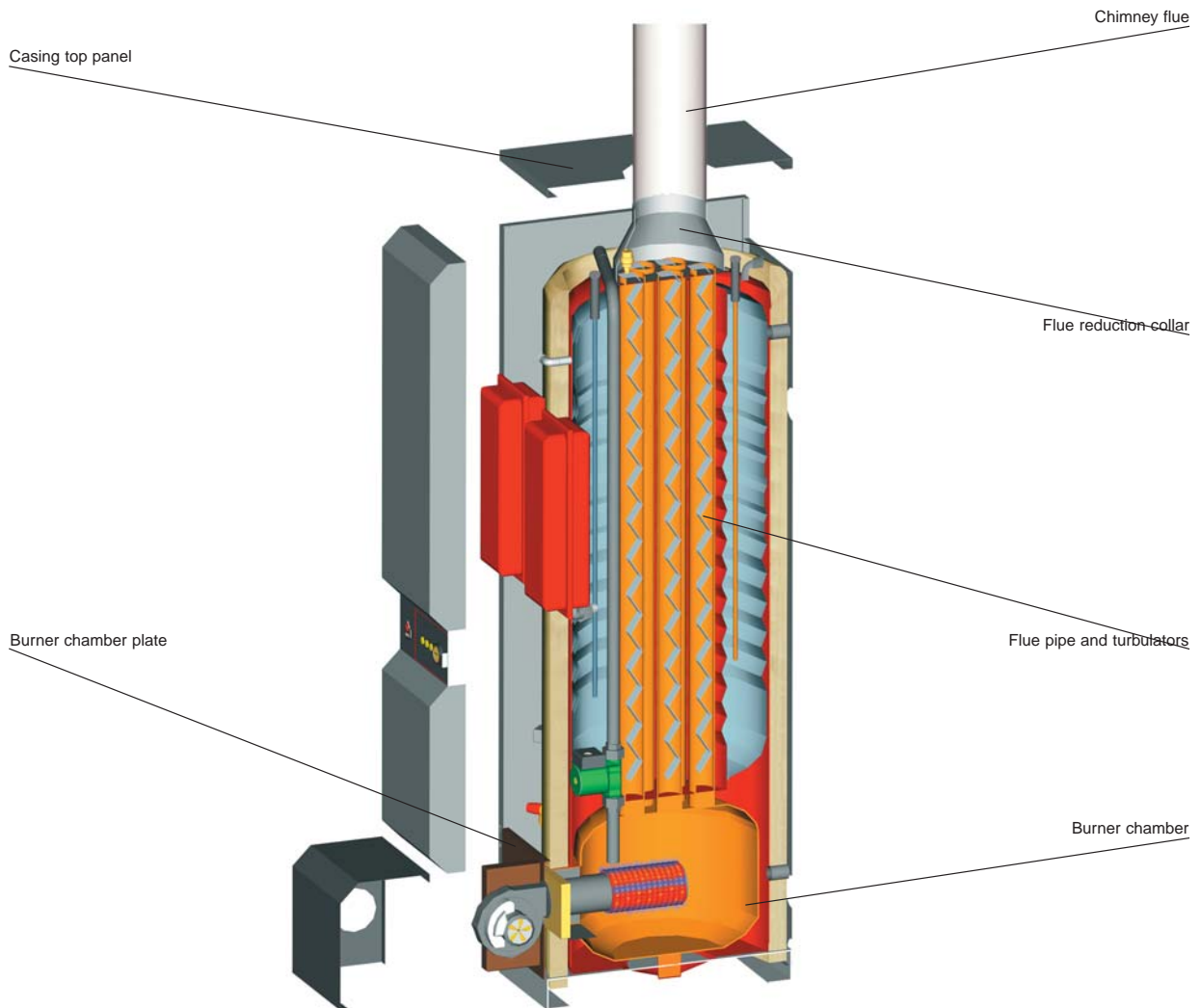

SERVICING THE SAFETY DEVICES

- Check that all thermostats and safety devices are working properly.
- Test the safety valves on the central heating and hot water circuits.

SERVICING THE BURNER

Oil burner

- Check and if necessary clean the main filter on the oil line.
- Check the alignment of the nozzle: check, clean or change the nozzle and its filter, check that the electrodes and flame holder are clean and correctly adjusted.
- Reassemble and check that the safety components are working properly.
- Set the combustion parameters.
- Check the combustion (CO₂, CO and burner pressure) and record the values and any remarks in the Service Record on page 24.

Gas burner

- Check that the insulation and gasket on the burner chamber plate are in good condition - replace if necessary.
- Check and clean the burner and electrodes. Replace electrodes if necessary (*under normal use once a year*).
- Check that the safety components are working properly.
- Check the combustion (CO₂, CO and gas pressure) and record the values and any remarks in the Service Record on page 24.

DRAINING THE BOILER



Water flowing out of the drain cock may be extremely hot and could cause severe scalding. Keep people away from discharges of hot water.

Draining the heating circuit

1. Turn OFF the on/off switch on the boiler control panel, isolate external electrical supply, and turn off the gas or oil supply to the boiler.
2. Close the isolating valves (4).
3. Connect a hose to the drain cock (7).
4. Open the drain cock to drain the primary circuit.

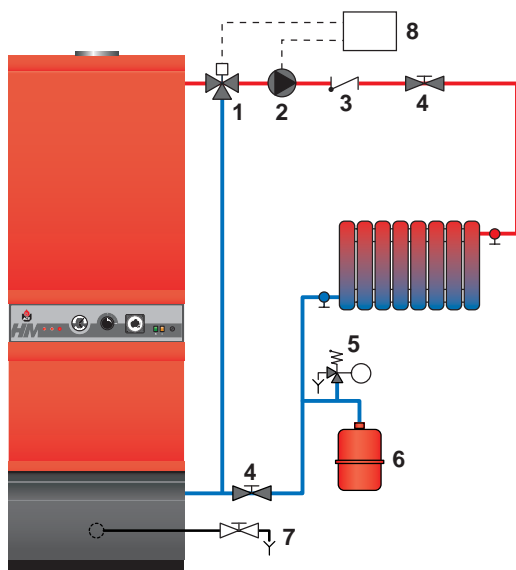

Draining the hot water circuit

1. Turn OFF the on/off switch on the boiler control panel, isolate external electrical supply, and turn off the gas or oil supply to the boiler.
2. Release the pressure in the heating circuit until the pressure gauge indicates zero bar.
3. Close stop cock (1) and turn off tap (8).
4. Open valve (9) then valve (10) (first 9 then 10).
5. Let the water empty into the drain.

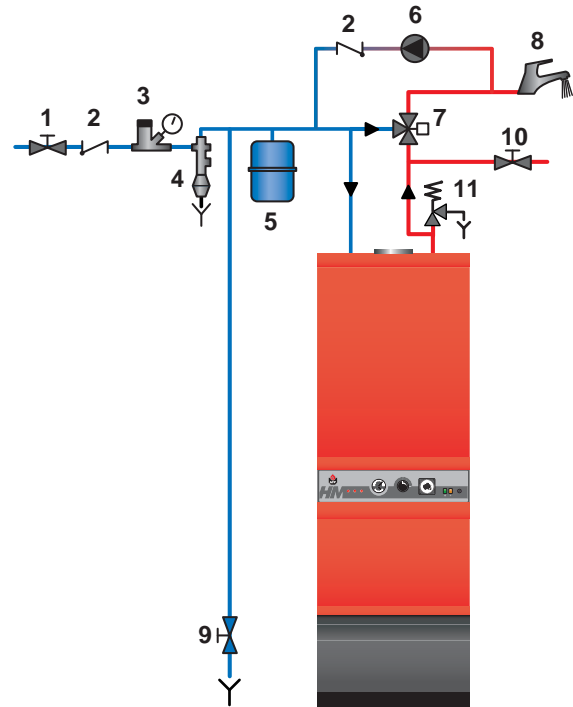

For the tank to be emptied, valve (9) must be situated at ground level.

SPARE PARTS

Please refer to the specific document available from ACV or your distributor.

USER GUIDE

USING THE BOILER



Your system should be serviced at least once a year by a qualified engineer. If the boiler is subject to heavy use, it may require servicing more than once a year - consult your service engineer for advice.

Starting the burner:

In normal operation, the burner starts automatically whenever the boiler temperature falls below the set temperature.

Understanding the control panel

There are no user parts inside the control panel.

1. On/Off switch

This turns the HeatMaster on or off.

2. Control thermostat - 60 to 90 °C

When using the HeatMaster as a hot water generator only, the temperature can be set between 60 °C and 90 °C. If the HeatMaster is used for both hot water and central heating, the control thermostat would normally be set at 80 °C to achieve optimum operating conditions.

3. Summer/Winter switch

This turns the heating pump (if fitted) on or off.

4. Manual reset high limit thermostat

If the boiler temperature exceeds 103 °C this safety device will activate and the high temperature indicator will light up. To reset - first allow the boiler to cool to below 60 °C, unscrew the cap and press the reset button using a pencil or similar pointed device, replace the cap. If the fault persists, turn the boiler off and call an engineer.

5. Time clock

This allows the HeatMaster to be timed on and off and operates on a 24 hour sequence. Around the outside of the clock there are a number of white tabs, these allow 15 minute switching periods. To set the time clock simply push outwards the number of tabs required for ON period.

Remember: TAB IN = HeatMaster OFF
 TAB OUT = HeatMaster ON

6. Temperature and pressure gauge

This gauge indicates both the temperature of the HeatMaster and the pressure within the primary circuit.

The temperature should not exceed 90 °C - if it does, switch the boiler off and check the thermostat setting. If the fault persists, call an engineer.

The pressure should not fall below 1bar, if it does the please see the 'Heating System Pressure' paragraph later in this section.

7. Low primary water pressure indicator

If this indicator lights up, the primary circuit of the HeatMaster requires topping up with water. Please see the 'Heating System Pressure' paragraph later in this section.

Control panel HeatMaster 60 N

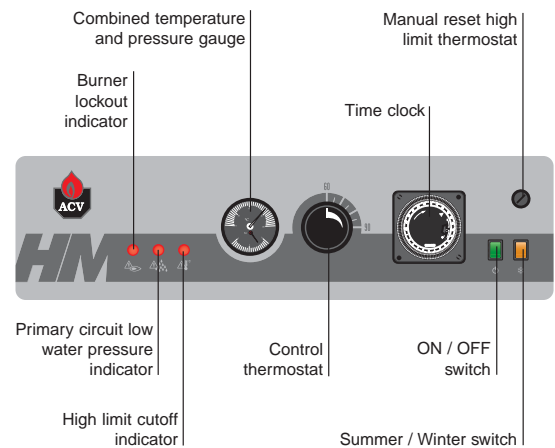

Control panel HeatMaster 70 N and HeatMaster 100 N

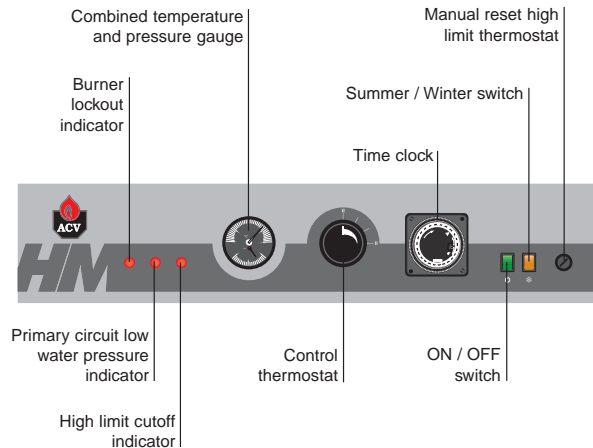

Control panel HeatMaster 150 Jumbo

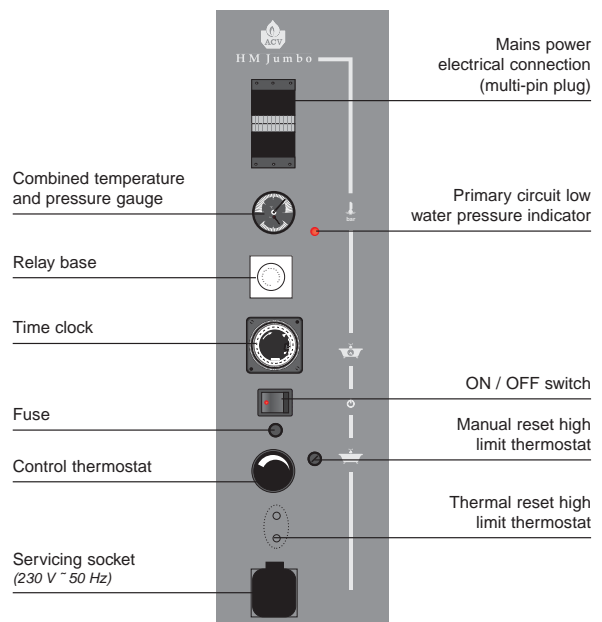

Heating system pressure



From time to time you may need to top up the heating system pressure. This pressure is indicated by the combined temperature and pressure gauge on the boiler control panel.

The minimum pressure when the boiler is cold should be 1 bar. The precise operating pressure required depends on the height of the building, and your installer will have informed you of this value at the time of installation (see *Commissioning Section - Filling the hot water and heating circuits*).

If the pressure falls below 1 bar, the boiler water pressure switch will turn the boiler off until pressure is restored.

To re-pressurise, the system needs to be topped up with water.

First, switch the boiler OFF on the on/off switch and isolate the external electrical supply. Then remove the casing top front panel by pulling it forward. The filling valves "A" and "B" can now be seen. Open both valves and allow the system to fill. When the combined temperature and pressure gauge shows the required pressure, close both valves. Replace the casing top front panel. Restore the power supply and switch the boiler on.

Safety Valves

If water discharges from any of the safety valves, switch the boiler off and call a service engineer.

HeatMaster 70 N and 100 N

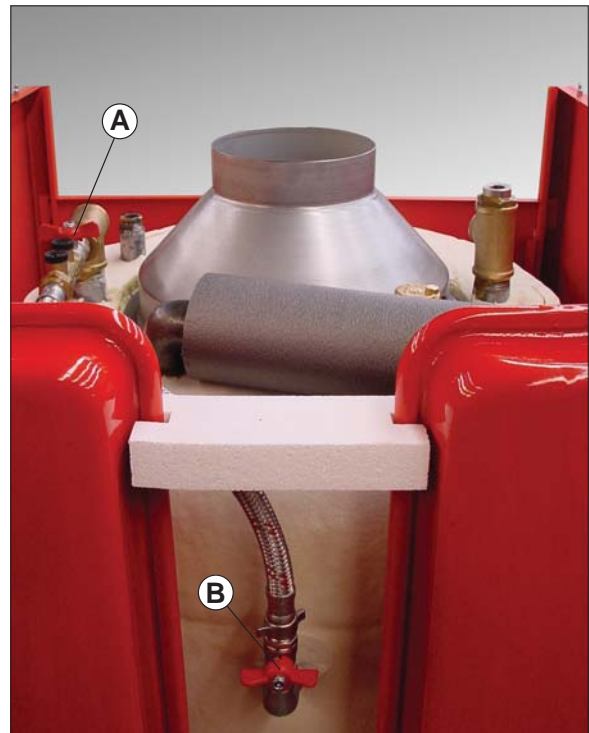

HeatMaster 60 N

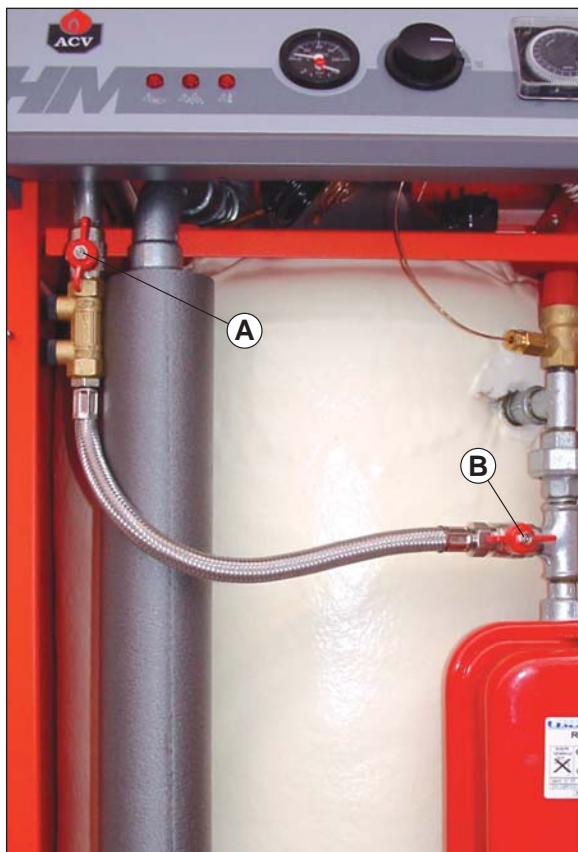

HeatMaster 150 Jumbo

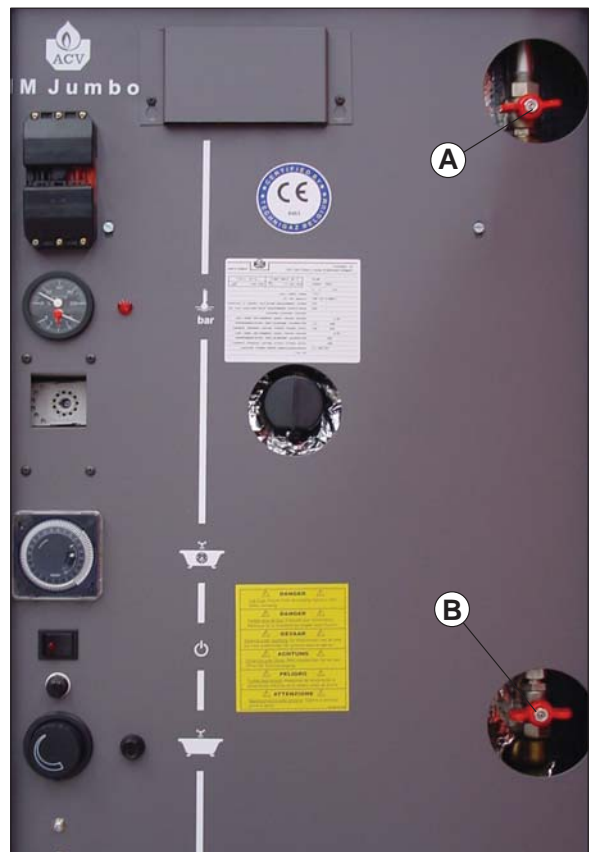

USER GUIDE

RESETTING THE PRESSURE JET OIL OR GAS BURNER

- HM 60 N and HM Jumbo 150
⇒ the lockout indicator is situated on the burner.
- HM 70 N and 100 N
⇒ the lockout indicator is situated on the burner and on the control panel.

The red warning light indicates an operating fault. Wait five minutes before resetting the burner. To reset : press the button located on the burner.

If the burner does not relight, call the service engineer after ensuring that the fault is not due to a power cut or low oil in the tank.



RESETTING THE BG 2000-S PREMIX GAS BURNER

- HM 60 N BG 2000-S/60
⇒ the lockout indicator is situated on the burner.
 - HM 70 N BG 2000-S/70 and HM 100 N BG 2000-S/100
⇒ the lockout indicator is situated on the burner and on the control panel.
1. Remove the burner cover.
 2. Press the red button to restart the burner.



3. If the burner lights, replace the cover.
4. If the fault persists, call a service engineer.

BURNER TROUBLESHOOTING

For all burners - please refer to the relevant servicing and troubleshooting instructions in your burner's technical manual.

INSTALLATION DETAILS

Date installed : _____	Flue gas T° : _____	Model : _____
% CO₂ (min. load) : _____	_____	Serial number : _____
_____	Efficiency : _____	Heating system pressure setting : _____
% CO₂ (max. load) : _____	Gas pressure : _____	
<input type="checkbox"/> Gas LPG	Name and signature : _____	
<input type="checkbox"/> Oil		

SERVICE RECORD

Date serviced : _____	Flue gas T° : _____	Remarks : _____
% CO₂ (min. load) : _____	_____	_____
_____	Efficiency : _____	_____
% CO₂ (max. load) : _____	Gas pressure : _____	
<input type="checkbox"/> Gas LPG	Name and signature : _____	
<input type="checkbox"/> Oil		

Date serviced : _____	Flue gas T° : _____	Remarks : _____
% CO₂ (min. load) : _____	_____	_____
_____	Efficiency : _____	_____
% CO₂ (max. load) : _____	Gas pressure : _____	
<input type="checkbox"/> Gas LPG	Name and signature : _____	
<input type="checkbox"/> Oil		

Date serviced : _____	Flue gas T° : _____	Remarks : _____
% CO₂ (min. load) : _____	_____	_____
_____	Efficiency : _____	_____
% CO₂ (max. load) : _____	Gas pressure : _____	
<input type="checkbox"/> Gas LPG	Name and signature : _____	
<input type="checkbox"/> Oil		

Date serviced : _____	Flue gas T° : _____	Remarks : _____
% CO₂ (min. load) : _____	_____	_____
_____	Efficiency : _____	_____
% CO₂ (max. load) : _____	Gas pressure : _____	
<input type="checkbox"/> Gas LPG	Name and signature : _____	
<input type="checkbox"/> Oil		

Date serviced : _____	Flue gas T° : _____	Remarks : _____
% CO₂ (min. load) : _____	_____	_____
_____	Efficiency : _____	_____
% CO₂ (max. load) : _____	Gas pressure : _____	
<input type="checkbox"/> Gas LPG	Name and signature : _____	
<input type="checkbox"/> Oil		

SERVICE RECORD

Date serviced :	Flue gas T° :	Remarks :
% CO ₂ (min. load) :		
	Efficiency :	
% CO ₂ (max. load) :	Gas pressure :	
<input type="checkbox"/> Gas LPG	Name and signature :	
Oil		

Date serviced :	Flue gas T° :	Remarks :
% CO ₂ (min. load) :		
	Efficiency :	
% CO ₂ (max. load) :	Gas pressure :	
<input type="checkbox"/> Gas LPG	Name and signature :	
Oil		

Date serviced :	Flue gas T° :	Remarks :
% CO ₂ (min. load) :		
	Efficiency :	
% CO ₂ (max. load) :	Gas pressure :	
<input type="checkbox"/> Gas LPG	Name and signature :	
Oil		

Date serviced :	Flue gas T° :	Remarks :
% CO ₂ (min. load) :		
	Efficiency :	
% CO ₂ (max. load) :	Gas pressure :	
<input type="checkbox"/> Gas LPG	Name and signature :	
Oil		

Date serviced :	Flue gas T° :	Remarks :
% CO ₂ (min. load) :		
	Efficiency :	
% CO ₂ (max. load) :	Gas pressure :	
<input type="checkbox"/> Gas LPG	Name and signature :	
Oil		

Date serviced :	Flue gas T° :	Remarks :
% CO ₂ (min. load) :		
	Efficiency :	
% CO ₂ (max. load) :	Gas pressure :	
<input type="checkbox"/> Gas LPG	Name and signature :	
Oil		

SERVICE RECORD

Date serviced :	Flue gas T° :	Remarks :
% CO ₂ (min. load) :		
	Efficiency :	
% CO ₂ (max. load) :	Gas pressure :	
<input type="checkbox"/> Gas LPG	Name and signature :	
Oil		

Date serviced :	Flue gas T° :	Remarks :
% CO ₂ (min. load) :		
	Efficiency :	
% CO ₂ (max. load) :	Gas pressure :	
<input type="checkbox"/> Gas LPG	Name and signature :	
Oil		

Date serviced :	Flue gas T° :	Remarks :
% CO ₂ (min. load) :		
	Efficiency :	
% CO ₂ (max. load) :	Gas pressure :	
<input type="checkbox"/> Gas LPG	Name and signature :	
Oil		

Date serviced :	Flue gas T° :	Remarks :
% CO ₂ (min. load) :		
	Efficiency :	
% CO ₂ (max. load) :	Gas pressure :	
<input type="checkbox"/> Gas LPG	Name and signature :	
Oil		

Date serviced :	Flue gas T° :	Remarks :
% CO ₂ (min. load) :		
	Efficiency :	
% CO ₂ (max. load) :	Gas pressure :	
<input type="checkbox"/> Gas LPG	Name and signature :	
Oil		

Date serviced :	Flue gas T° :	Remarks :
% CO ₂ (min. load) :		
	Efficiency :	
% CO ₂ (max. load) :	Gas pressure :	
<input type="checkbox"/> Gas LPG	Name and signature :	
Oil		

SERVICE RECORD

Date serviced :	Flue gas T° :	Remarks :
% CO ₂ (min. load) :		
	Efficiency :	
% CO ₂ (max. load) :	Gas pressure :	
<input type="checkbox"/> Gas LPG	Name and signature :	
Oil		

Date serviced :	Flue gas T° :	Remarks :
% CO ₂ (min. load) :		
	Efficiency :	
% CO ₂ (max. load) :	Gas pressure :	
<input type="checkbox"/> Gas LPG	Name and signature :	
Oil		

Date serviced :	Flue gas T° :	Remarks :
% CO ₂ (min. load) :		
	Efficiency :	
% CO ₂ (max. load) :	Gas pressure :	
<input type="checkbox"/> Gas LPG	Name and signature :	
Oil		

Date serviced :	Flue gas T° :	Remarks :
% CO ₂ (min. load) :		
	Efficiency :	
% CO ₂ (max. load) :	Gas pressure :	
<input type="checkbox"/> Gas LPG	Name and signature :	
Oil		

Date serviced :	Flue gas T° :	Remarks :
% CO ₂ (min. load) :		
	Efficiency :	
% CO ₂ (max. load) :	Gas pressure :	
<input type="checkbox"/> Gas LPG	Name and signature :	
Oil		

Date serviced :	Flue gas T° :	Remarks :
% CO ₂ (min. load) :		
	Efficiency :	
% CO ₂ (max. load) :	Gas pressure :	
<input type="checkbox"/> Gas LPG	Name and signature :	
Oil		



excellence in hot water

www.acv-world.com

INTERNATIONAL

ACV international n.v
KERKPLEIN, 39
B-1601 RUISBROEK - BELGIUM
TEL.: +32 2 334 82 20
FAX: +32 2 378 16 49
E-MAIL: international.info@acv-world.com

BELGIUM

ACV BELGIUM nv/sa
KERKPLEIN, 39
B-1601 RUISBROEK-BELGIUM
TEL.: +32 2 334 82 40
FAX: +32 2 334 82 59
E-MAIL: belgium.info@acv-world.com

CHILE

ALBIN TROTTER Y ACV LTDA
SAN PABLO 3800
QUINTA NORMAL - SANTIAGO - CHILE
TEL.: +56 2 772 01 69
FAX: +56 2 772 92 62/63
E-MAIL: chile.info@acv-world.com

CZECH REPUBLIC

ACV CR SPOL. s.r.o
NA KRECKU 365
CR-109 04 PRAHA 10 - CZECH REPUBLIC
TEL.: +420 2 720 83 341
FAX: +420 2 720 83 343
E-MAIL: ceskarepublika.info@acv-world.com

DEUTSCHLAND

ACV WÄRMETECHNIK GMBH & CO KG
GEWERBEGBIET GARTENSTRASSE
D-08132 MÜLSEN OT. JACOB - DEUTSCHLAND
TEL.: +49 37601 311 30
FAX: +49 37601 311 31
E-MAIL: deutschland.info@acv-world.com

ARGENTINA

TECNO PRACTICA
ALFEREZ BOUCHARD 4857
1605 CARAPACHAY - BUENOS AIRES
TEL.: +54 11 47 65 33 35
FAX: +54 11 47 65 43 07
E-MAIL: jchas@tecnopractica.com

BRAZIL

SIMETAL INDUSTRIA E COMERCIO DE FERRAMENTAS LTDA
RUA GERSON ANDREIS 535
95112 - 130 CAXIAS DO SUL - BRAZIL
TEL.: +55 54 227 12 44
FAX: +55 54 227 12 26
E-MAIL: export@simetal.com.br

BULGARIA

PROXIMUS ENGINEERING LTD
7 BIAL KREM STR.
9010 VARNA - BULGARIA
TEL.: +359 52 500 070
FAX: +359 52 301 131
E-MAIL: info@proximus-bg.com

CHINA

BEIJING HUADIAN HT POWER TECHNOLOGY DEVELOPMENT CO. LTD
ROOM B-912, TOWER B, COFCO PLAZA
Nº. 8, JIANGUOMENNEI AVENUE
BEIJING 100005 - PEOPLE'S REPUBLIC OF CHINA
TEL.: +86 10 652 30 363/393 EXT 101
FAX: +86 10 652 27 071
E-MAIL: li.zheng@acv-world.com

DENMARK

VARMEHUSET
FRICHSVEJ 40 A
8600 SILKEBORG - DENMARK
TEL.: +45 86 82 63 55
FAX: +45 86 82 65 03
E-MAIL: vh@varmehuset.dk

ESPAÑA

ACV ESPAÑA
C/DE LA TEIXIDORA, 76
POL. IND. LES HORTES
E-08302 MATARÓ - ESPAÑA
TEL.: +34 93 759 54 51
FAX: +34 93 759 34 98
E-MAIL: spain.info@acv-world.com

FRANCE

ACV FRANCE sa
31, RUE AMPERE - Z.I MI - PLAINE
F-69680 CHASSIEU - FRANCE
TEL.: +33 4 72 47 07 76
FAX: +33 4 72 47 08 72
E-MAIL: france.info@acv-world.com

ITALIA

ACV ITALIA
VIA PANÀ 92
I-48018 FAENZA (RA) - ITALIA
TEL.: +39 0546 64 61 44
FAX: +39 0546 64 61 50
E-MAIL: italia.info@acv-world.com

NEDERLAND

ACV NEDERLAND bv
POSTBUS 350
NL-2980 AJ RIDDERKERK - NEDERLAND
TEL.: +31 180 42 10 55
FAX: +31 180 41 58 02
E-MAIL: nederland.info@acv-world.com

POLAND

ACV POLSKA sp. z o.o.
UL. WITOSA 3
87 - 800 WWOVCWAWEK - POLAND
TEL.: +48 54 412 56 00
FAX: +48 54 412 56 01
E-MAIL: polska.info@acv-world.com

ESTONIA

TERMOMX AS
TAHE 112A
51013 TARTU - ESTONIA
TEL.: +372 736 73 39
FAX: +372 736 73 44
E-MAIL: termomx@termomx.ee

GREECE

ESTIAS
MARASLI STREET 7
54248 THESSALONIKI - GREECE
TEL.: +30 23 10 31 98 77 / +30 23 10 32 03 58
FAX: +30 23 10 31 97 22
E-MAIL: info@genikithermanson.gr

ÎLE MAURICE

SOTRATECH
29, RUE MELDRUM
BEAU BASSIN - ÎLE MAURICE
TEL.: +230 46 76 970
FAX: +230 46 76 971
E-MAIL: stech@intnet.mu

LITHUANIA

UAB "GILIUS IR KO"
SAVARNORIŲ PR. 192
3000 KAUNAS - LITHUANIA
TEL.: +370 37 308 930
FAX: +370 37 308 932

MAROC

CASATHERM
PLACE EL YASSIR
20300 CASABLANCA - MAROC
TEL.: +212 22 40 15 23
FAX: +212 22 24 04 86

MOLDAVIA

STIMEX - PRIM S.R.L.
STR BUCURESTI, 60A
2012 CHISINAUJ - MOLDAVIA
TEL.: +37 32 22 46 75
FAX: +37 32 27 24 56
E-MAIL: stimex@slavik.mldnet.com

PORTUGAL

BOILERNOX LDA
RUA OUTEIRO DO POMAR
CASAL DO CEGO, FRACÇÃO C,
PAVILHÃO 3 - MARRAZES
2400-402 LEIRIA - PORTUGAL
TEL.: +351 244 837 239/40
FAX: +351 244 823 758
E-MAIL: boilernox@mail.telepac.pt

RUSSIA

ACV RUSSIA
1/9, MALYI KISELNYI
103031 MOSCOW - RUSSIA
TEL.: +7 095 928 48 02 / +7 095 921 89 79
FAX: +7 095 928 08 77
E-MAIL: russia.info@acv-world.com

SLOVAK REPUBLIC

ACV SLOVAKIA s.r.o.
PLUHOVÁ 49
831 04 BRATISLAVA - SLOVAK REPUBLIC
TEL.: +421 2 444 62 276
FAX: +421 2 444 62 275
E-MAIL: slovakia.info@acv-world.com

UK

ACV UK Ltd
ST. DAVID'S BUSINESS PARK
DALGETY BAY - FIFE - KY11 9PF
TEL.: +44 1383 82 01 00
FAX: +44 1383 82 01 80
E-MAIL: uk.info@acv-world.com

USA

TRIANGLE TUBE PHASE III
FREEWAY CENTER - 1 TRIANGLE LANE
BLACKWOOD NJ 08012 - USA
TEL.: +1 856 228 8881
FAX: +1 856 228 3584
E-MAIL: sales@triangletube.com

ÖSTERREICH

PROTHERM HEIZUNGSTECHNIK GmbH
TRAUNJUFERSTRASSE 113
4052 ANSFELDEN - ÖSTERREICH
TEL.: +43 7229 804 82
FAX: +43 7229 804 92
E-MAIL: protherm@nexttra.at

ROMANIA

SC TRUST EURO THERM SA
D.N. PIATRA NEAMT - ROMANIA
km 2 C.P. 5 O.P. 3 jud. Neamt
5600 PIATRA NEAMT - ROMANIA
TEL.: +40 233 20 62 06
FAX: +40 233 20 62 00
E-MAIL: office@eurotherm.ro

SLOVENIA

Z'MAJ d.o.o.
CESTA OF 49
1420 TRBOVLJE - SLOVENIA
TEL.: +386 356 32 830
FAX: +386 356 32 831
E-MAIL: jjeraj@zmej.si

SWEDEN

WÄRMEPRODUKTER I KLIPPAN AB
TEMPLAREGÅTAN 7
26435 KLIPPAN - SWEDEN
TEL.: +46 435 184 10
FAX: +46 435 184 02
E-MAIL: varmeprodukter.se@telia.com

TUNISIE

SO.CO.ME CHAUMAX
BOÎTE POSTALE N°44
1002 TUNIS - TUNISIE
TEL.: +216 71 78 15 91
FAX: +216 71 78 87 31

UKRAINE

UKRTEPLOSERVICE LTD
PR. LAGUTENKO 14
83086 DONETSK - UKRAINE
TEL.: +38 062 382 60 47/48
FAX: +38 062 335 16 89