

INSTALLATION, OPERATION AND MAINTENANCE INSTRUCTIONS

HeatMaster®

71









101

201



excellence in hot water



- APPLICABILITY :**
-  664Y4900 - Rev E - Delta Pro S -Pro Pack, Installation, Operation and Maintenance Instructions
 -  664Y6100 - Rev B - HeatMaster 71 - 101 - 201 (V13), Installation, Operation and Maintenance Instructions
 -  664Y6300 - Rev B - HeatMaster 200N, Installation, Operation and Maintenance Instructions
 -  664Y6700 - Rev D - Prestige 24-32 Solo/Excellence, Installation, Operation and Maintenance Instructions
 -  664Y6900 - Rev D - HeatMaster 25 - 35 - 45 - 70 - 85 - 120 TC, Installation, Operation and Maintenance Instructions
 -  664Y7000 - Rev B - HeatMaster 25C, Installation, Operation and Maintenance Instructions
 -  664Y7200 - Rev B - Compact Condens 170 - 210 - 250 - 300, Installation, Operation and Maintenance Instructions
 -  664Y7300 - Rev C - WaterMaster 25 - 35 - 45 - 70 - 85 - 120, Installation, Operation and Maintenance Instructions



- EN** Make sure that the appliance is connected to the earth.
- FR** Veiller à ce que l'appareil soit raccordé à la terre.
- NL** Zorg ervoor dat het toestel is geaard.
- ES** Asegúrese de que el aparato esté conectado a tierra.
- IT** Assicurarsi che l'apparecchio sia elettricamente collegato alla messa a terra dell'impianto.
- DE** Stellen Sie sicher, dass das Gerät geerdet ist.
- PL** Upewnij się, że urządzenie jest uziemione.
- RU** Убедитесь, что прибор заземлен.



- EN** Check that the gas type and pressure from the distribution network are compatible with the appliance settings.
- FR** Vérifier que le type de gaz et la pression du réseau de distribution sont compatibles avec les réglages de l'appareil.
- NL** Controleer of het type gas en de druk van het distributienetwerk in overeenstemming zijn met de toestelinstellingen.
- ES** Compruebe que el tipo de gas y la presión de la red de distribución son compatibles con los ajustes del aparato.
- IT** Controllare che il tipo di gas e la pressione della rete di distribuzione siano compatibili con le impostazioni dell'apparecchio.
- DE** Stellen Sie sicher, dass die Gasart und der Druck des Verteilungsnetzes mit den Geräteeinstellungen kompatibel sind.
- PL** Sprawdzić, czy typ gazu i ciśnienie sieci dystrybucyjnej są zgodne z ustawieniami urządzenia.
- RU** Убедитесь, что тип газа и давление в распределительной сети совместимы с настройками прибора.

TABLE OF CONTENTS

WARNINGS	3	MAINTENANCE	23
Who should read these Instructions	3	Annual maintenance	23
Symbols	3	Boiler maintenance	23
Recommendations	3	Maintenance of the safety devices	23
Warnings	3	Burner maintenance	23
		Draining the boiler	23
USER GUIDE	4	DECLARATION OF CONFORMITY - EC	24
Use of the boiler	4		
Settings the parameters	5		
APPLIANCE DESCRIPTION	6	SPARE PARTS	www.acv.com
TECHNICAL CHARACTERISTICS	8		
Dimensions	8		
Boiler clearance	9		
Main electrical characteristics	10		
Combustion characteristics	12		
Hydraulic characteristics	12		
Domestic hot water performance	12		
Gas category	13		
Maximum operating conditions	13		
Boiler room	14		
Chimney connection	14		
Type C chimney connection	14		
Chimney connection characteristics	15		
BURNER CHARACTERISTICS	16		
Air/Gas pre-mix burners ACV BG 2000-M	16		
Burner adjustment	17		
INSTALLATION	18		
Package contents of the HeatMaster 71-101	18		
Boiler preparation	18		
Package contents of the HeatMaster 201	19		
DHW connection	20		
Heating connection	21		
Gas connection	21		
STARTING UP	22		
Filling the DHW and heating circuits	22		
Starting the boiler	22		
Bleeding the heating circuit	22		

CERTIFICATION

The appliances bear the "CE" mark, in accordance with the standards in force in the various countries [European Directives 92/42/EEC "Efficiency", 2009/142/EC "Gas Appliances". These appliances also bear the Belgian gas boiler quality labels "HR+"[gas boiler].



Certified ISO 9001 quality system

WARNINGS

WHO SHOULD READ THESE INSTRUCTIONS

The manual should be read by:

- The specifying engineer
- The user
- The installer
- The maintenance technician

SYMBOLS

The following symbols are used in this manual:



Essential instruction for the correct operation of the installation



Essential instruction for the safety of persons and the environment



Danger of electrocution



Risk of scalding

RECOMMENDATIONS



- Please carefully read this manual before installing and starting up the boiler.
- It is prohibited to carry out any modifications to the inside of the appliance without the manufacturer's prior and written agreement.
- The product must be installed and serviced by an approved and qualified engineer, in accordance with applicable standards and regulations.
- Failure to comply with the operation instructions and test procedures can result in personal injury or a risk of environmental pollution.
- To guarantee safe and correct operation of the appliance, it is important to have it serviced and maintained every year by an approved installer or maintenance contractor.
- In case of anomaly, please call your service engineer.
- In spite of the strict quality standards that ACV applies to its appliances during production, inspection and transport, faults may occur. Please immediately notify your approved installer of any faults. Remember to indicate the fault code as it appears on the screen.
- The defective parts may only be replaced by genuine factory parts.
- The gas burners are factory preset for use with natural gas [equivalent to G20].
- Specific regulation applicable in Belgium [for the gas burners]: The CO₂ level, the air and gas flows and the gas/air ratio are factory preset. Any field adjustment of those settings is not allowed in Belgium, except for type 1 2E(R)B boilers.



- Before carrying out any work on the boiler, it is important to isolate the electrical supply to the unit.
- The user must not attempt to gain access to the components inside the boiler or the control panel.
- This appliance is not intended for use by persons (including children) with reduced physical, sensory or mental capabilities, or lack of experience and knowledge, unless supervised or unless they have been given instruction concerning the use of the appliance by a person responsible for their safety.

WARNINGS

If you smell gas:

- Immediately isolate the gas supply.
- Open windows and doors to ventilate the area.
- Do not use any electrical appliances and do not operate any switches.
- Immediately notify your gas supplier and/or your installer.

This manual is part of the items delivered with the appliance and must be given to the user and stored in a safe place!

An approved installer must carry out the installation, starting up, maintenance and repair of the system, in accordance with current standards in force.

The manufacturer declines all liability for any damage caused as a result of incorrect installation or in the event of the use of appliances or accessories that are not specified by the manufacturer.



The manufacturer reserves the right to change the technical characteristics and features of its products without prior notice.



The availability of certain models as well as their accessories may vary according to markets.

USE OF THE BOILER



ACV recommends that the boiler is inspected and serviced, if required, at least once a year by a competent and qualified engineer. More frequent servicing may be required depending on boiler use, if this is the case consult your installer for advice.

Starting the burner:

In normal operation, the burner starts automatically as soon as the boiler drops below the temperature setpoint.

The user must not attempt to gain access to the components inside the control panel.

HeatMaster® control panel

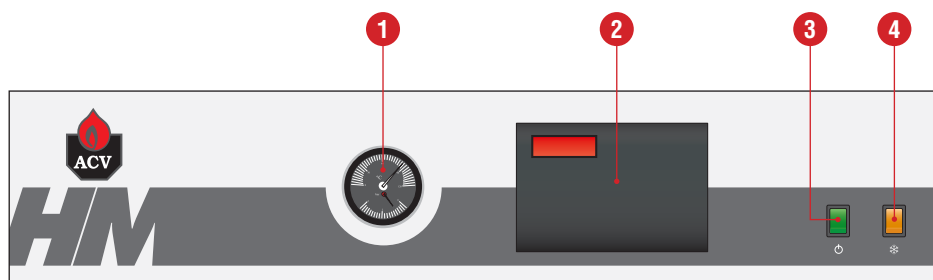

1. Temperature-pressure gauge
2. Display - MCBA controller
3. General switch
4. Summer/winter switch

Heating System Pressure



From time to time you may need to top up the heating circuit water level to get the required pressure in the system. The circuit pressure is indicated by the combined temperature and pressure gauge on the boiler control panel.

The minimum pressure when the boiler is cold should be 1 bar. The precise operating pressure required depends on the height of the building and your installer will have informed you of this value at the time of installation (see Starting up section - Filling the DHW and heating circuits).

If the pressure falls below 1 bar, the boiler water pressure switch will turn the boiler off until the pressure is restored

To restore the pressure, top up the heating circuit with water by opening the filling valve (A) of the boiler primary circuit and allow the system to fill. Once the pressure gauge of the boiler control panel indicates the required pressure, close the filling valve.

Safety valves

If water discharges from any of the safety valves, turn the boiler off and call a service engineer.

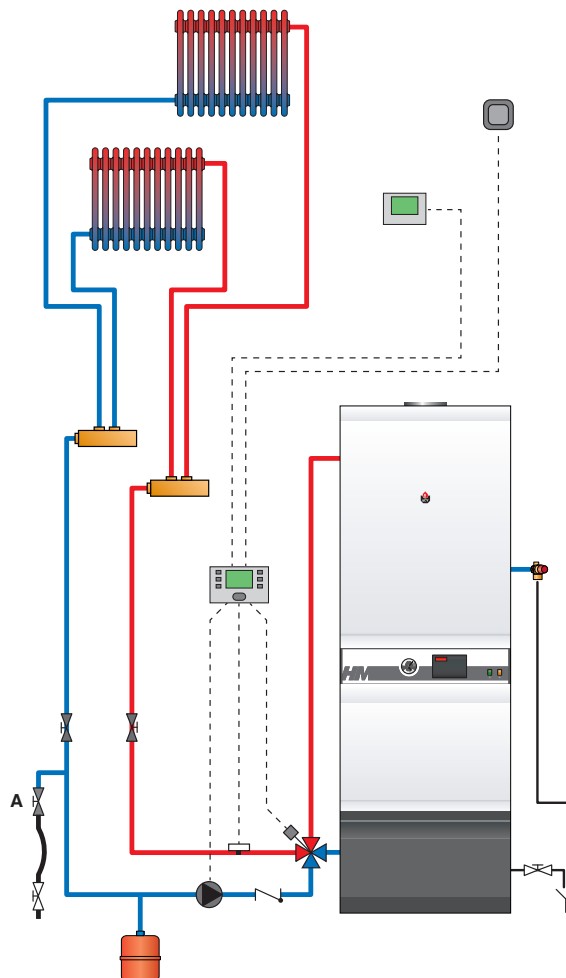

SETTING THE PARAMETERS

- **Domestic hot water temperature instruction:**

(Hot water temperature)

- Press the **"mode"** key once: the screen indicates **"PARA"**.
- Press the **"step"** key: the first digit is **1** and the last two digits indicate the current hot water temperature setting.
- To change this temperature, press **"+"** or **"-"** keys until the temperature indicated by the last two digits is the desired temperature.
- Press **"store"** to save the setting.
- Press the **"mode"** key twice to return to normal operating mode [Stand-by).

- **Enabling and disabling hot water mode:**

(Hot water)

- Press **"mode"** once: the screen displays **"PARA"**.
- Press the **"step"** key twice: the first digit is **2** and the last two digits indicate the current setting.
00 = disabled; **01** = enabled.
- To change this parameter, press the **"+"** or **"-"** keys until you reach the desired value:
00 = disabled; **01** = enabled.
- Press the **"store"** key to save the setting.
- Press the **"mode"** key twice to return to normal operating mode [Stand-by).

- **Enabling and disabling central heating mode:**

(Central heating)

- Press the **"mode"** key once: the screen displays **"PARA"**.
- Press the **"step"** key three times: the first digit is **3** and the last two digits indicate the current setting.
00 = disabled; **01** = enabled.
- To change this parameter, press the **"+"** or **"-"** keys until you reach the desired value:
00 = disabled; **01** = enabled.
- Press **"store"** key to save the setting.
- Press the **"mode"** key twice to return to normal operating mode [Stand-by).

- **Setting the temperature of the central heating:**

(the maximum temperature for the heating circuit)

- Press **"mode"** once: the screen displays **"PARA"**.
- Press the **"step"** key four times: the first digit is **4** and the last two digits indicate the current temperature setting for the central heating.
- To change this temperature, press the **"+"** or **"-"** keys until the temperature indicated by the last two digits is the desired temperature.
- Press **"store"** to save the setting.
- Press the **"mode"** key twice to return to normal operating mode [Stand-by).

Display MCBA



Fault:

The temperature setting of the appliance and the safety functions of its various parts are constantly monitored by the MCBA controller. If a fault occurs, the MCBA turns the unit off and indicates an error code: the display flashes and the first character is an **"E"** followed by the fault code (see "System control" manual).

To reset the unit:

- Press the **"reset"** key on the display panel.
- If the fault code appears again, contact your contractor.



APPLIANCE DESCRIPTION

Description HeatMaster® 71 / 101

1. Automatic air bleed valve
2. Cold water inlet
3. Dry well
4. Hard polyurethane foam insulation
5. Casing front panel
6. Primary expansion vessel
7. Control panel
8. Charging pump
9. Burner cover
10. Burner
11. Top cover
12. Flue reduction collar
13. Heating circuit outlet
14. Domestic hot water outlet
15. Stainless steel "Tank in Tank" hot water production tank
16. Flue pipes and turbulators
17. Primary circuit
18. Heating return
19. Combustion chamber
20. Burner chamber plate insulation
21. Draining valve

22. Gasket for the flue reduction collar
23. Casing reinforcement bracket

- A. Primary outlet temperature NTC 1 sensor
 B. Primary return temperature NTC 2 sensor
 C. DHW temperature NTC 3 sensor
 D. Low-water pressure switch
 E. Primary safety valve
 F. Pressure gauge connection

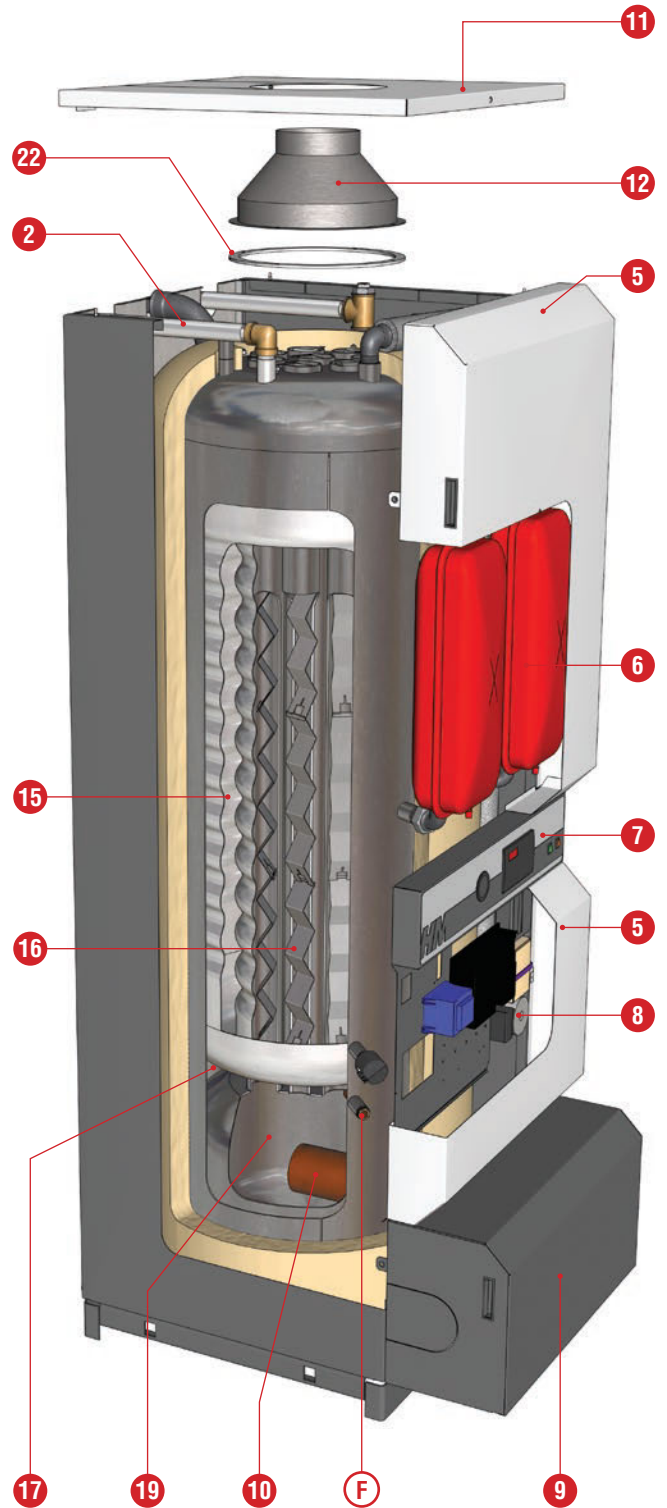
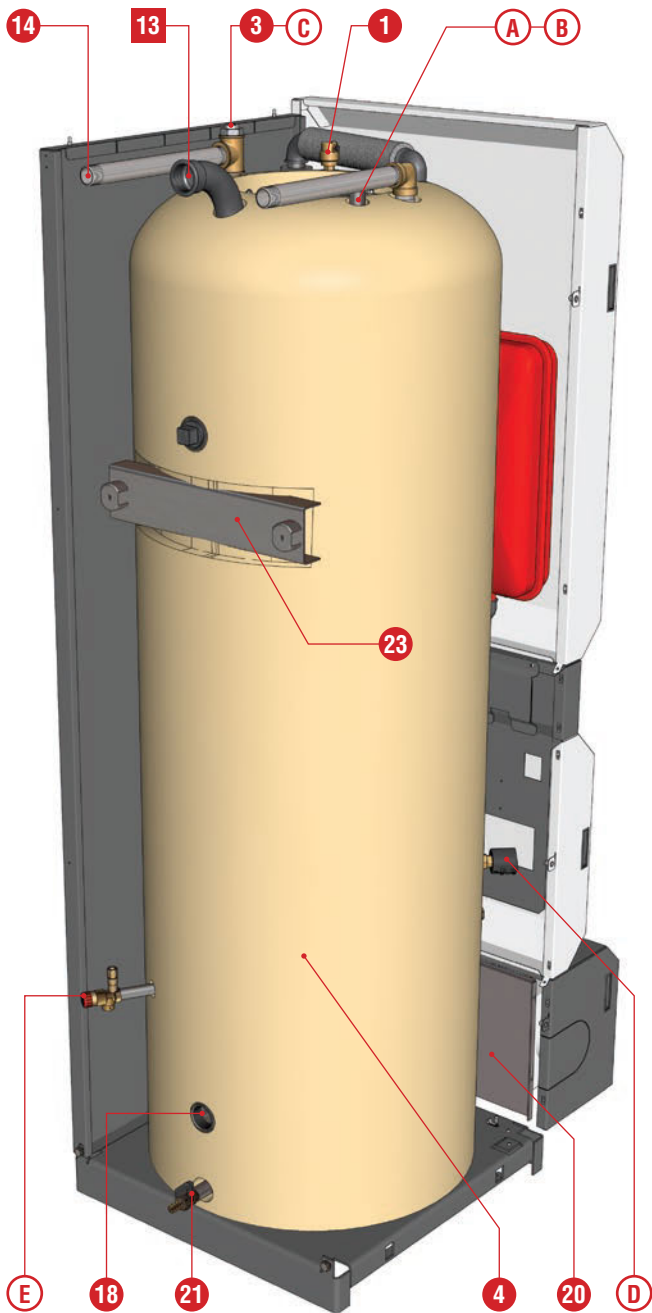

APPLIANCE DESCRIPTION

Description HeatMaster® 201

1. Chimney reduction with horizontal outlet (vertical outlet optional)
2. Cold water inlet
3. Primary NTC 1 and 2 sensors
4. T&P valve connection (optional)
5. Auto-air vent
6. Rigid polyurethane foam insulation
7. Internal stainless steel tank
8. Low-water pressure switch
9. Pressure gauge connection
10. Thermostat control bulb
11. Charging pump (2x)
12. Stainless steel dry-well with ECS NTC 3 sensor
13. Domestic hot water outlet
14. Heating flow
15. Filling loop connection
16. Filling of primary circuit
17. Primary expansion vessel (4x)
18. Flue gas tubes and turbulators
19. Heating return
20. Drain cock
21. Primary safety valve
22. Primary circuit tank
23. Combustion chamber

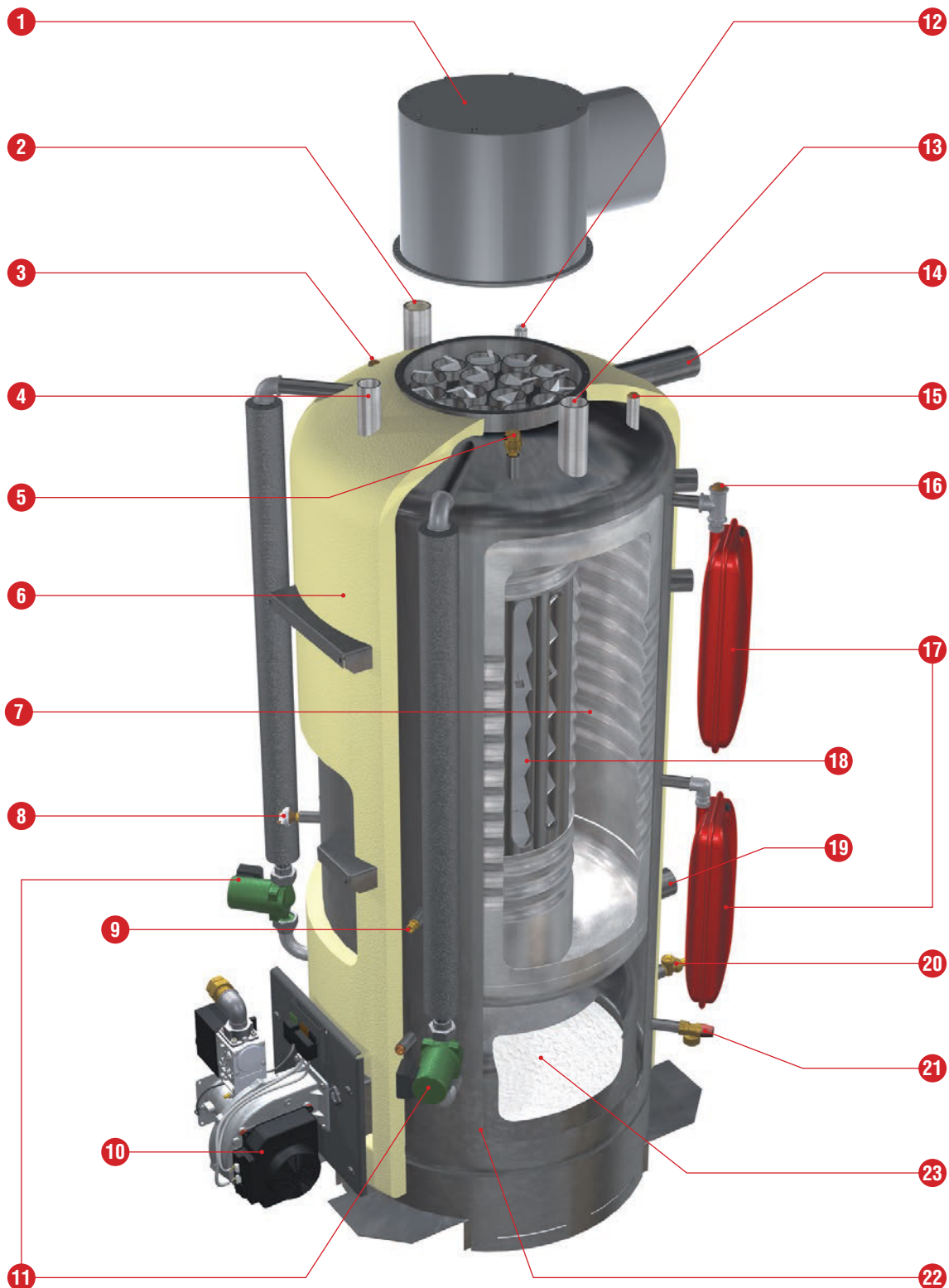

TECHNICAL CHARACTERISTICS

DIMENSIONS

HeatMaster® 71 / 101

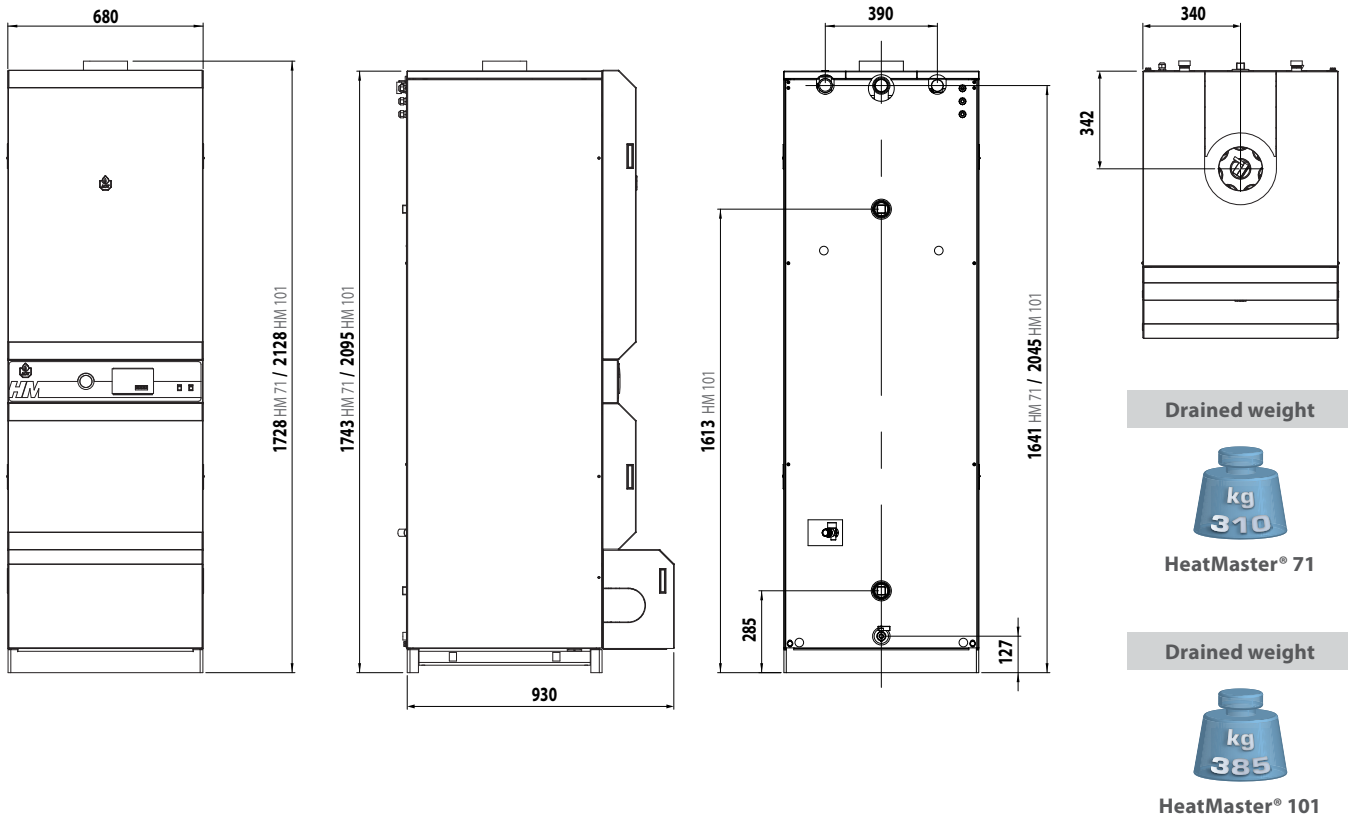

HeatMaster® 201

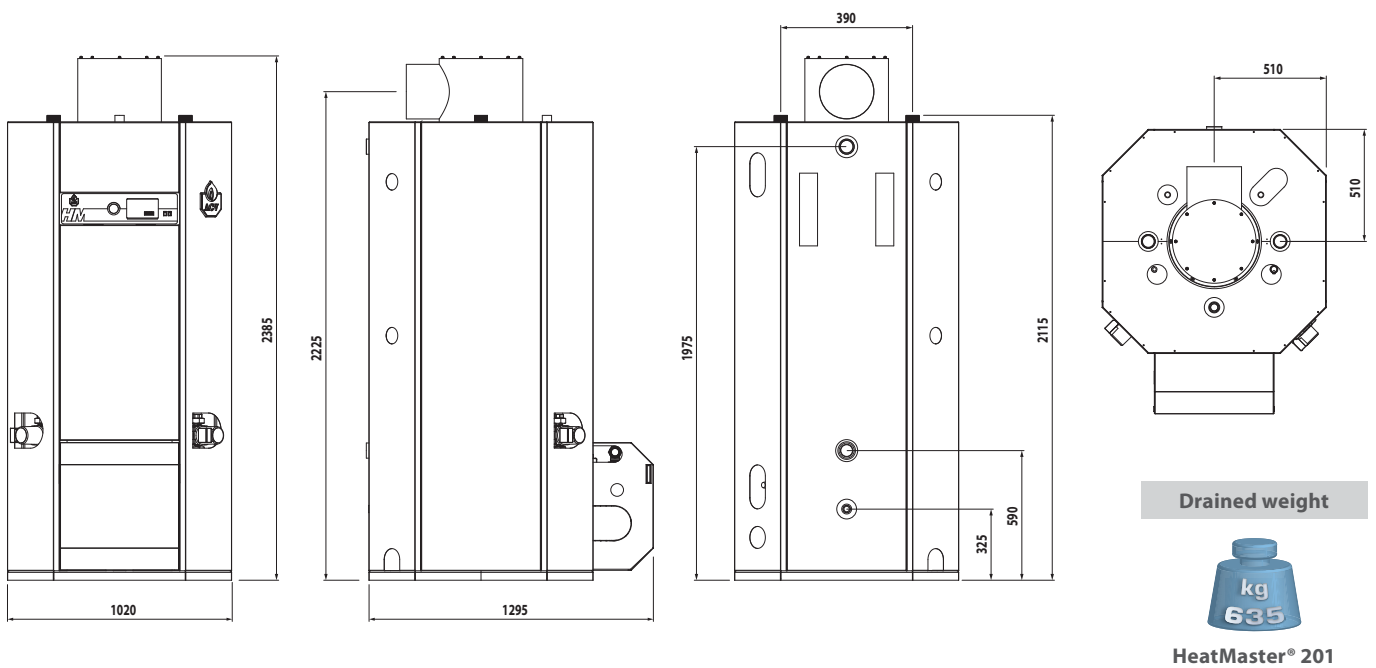

BOILER CLEARANCE

	Recommended	Minimum
A (mm)	650	500
B (mm)	800	700
C (mm)	500	300
D (mm)	300	250
E (mm)	150	100
F (mm)	800	700

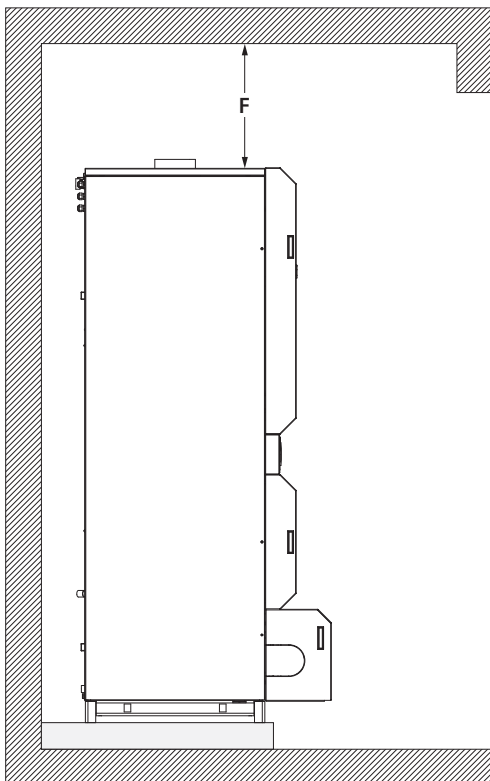
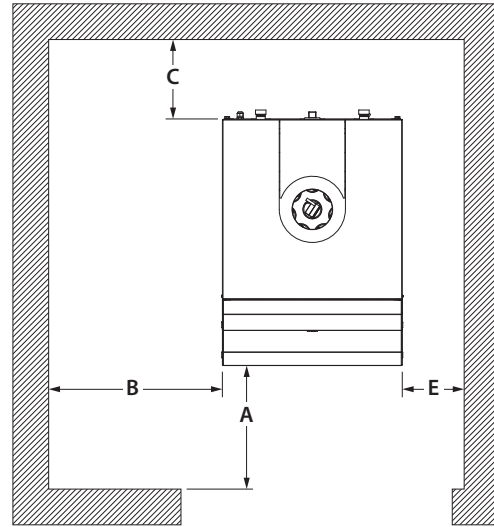
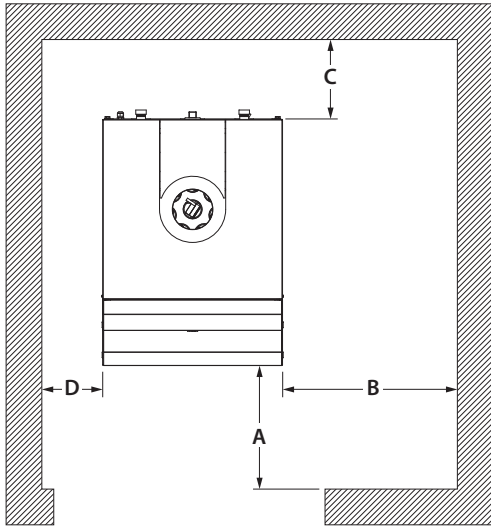

TECHNICAL CHARACTERISTICS

MAIN ELECTRICAL CHARACTERISTICS

		HeatMaster® 71	HeatMaster® 101	HeatMaster® 201
Operating voltage	V~	230	230	230
Rated frequency	Hz	50	50	50
Electrical consumption	W	220	230	730
Electrical power requirements	A	1	1	3,2
Protection IP		IP30	IP30	IP30

Wiring diagram HeatMaster® 71 / 101

- 230 Volt supply
- 230 Volt outlet for AM3-11 module (optional)
- Charging pump
- Heating pump
- General switch
- 230 Volt - 24 Volt transformer
- MCBA controller
- MCBA Display
- Ignition and ionisation cable
- Summer/winter switch

- 7 pin burner plug
- 4 pin burner plug
- Room thermostat (optional)
- Low water pressure safety switch
- Primary NTC1 temperature sensor
- Primary NTC2 temperature sensor
- NTC3 hot water temperature sensor
- NTC4 external temperature sensor (optional)
- NTC6 2nd heating circuit temperature sensor (optional)
- 0 - 24 Volt DC

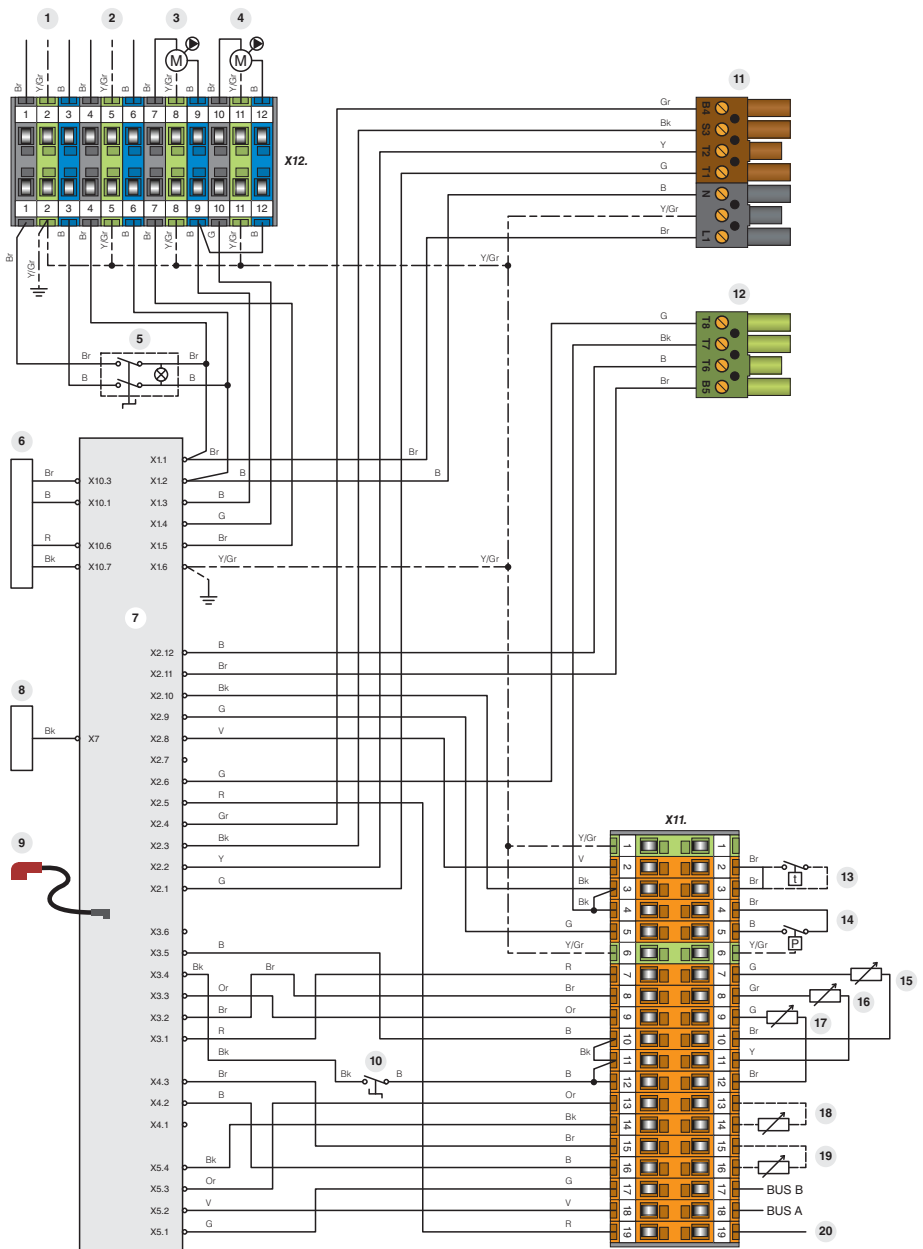

- B. Blue
- Bk. Black
- Br. Brown
- G. Grey
- Gr. Green
- Or. Orange
- Pk. Pink
- R. Red
- V. Violet
- W. With
- Y. Yellow
- Y/Gr. Yellow / Green

TECHNICAL CHARACTERISTICS

Wiring diagram HeatMaster® 201

1. General switch
2. Module AM3-11
3. Module AM3-2
4. MCBA controller
5. 24 Volt Transformer
6. MCBA Display
7. Room thermostat (optional)
8. Low water pressure safety switch
9. NTC1 primary temperature sensor
10. NTC2 primary temperature sensor
11. NTC3 hot water temperature sensor
12. NTC4 outside temperature sensor (optional)
13. Summer/winter switch
14. NTC6 heating circuit start sensor (optional)
15. Heating circulator (not supplied)
16. Heating circulator (not supplied) if four way valve is motor driven on AM3-11
17. Charging pump
18. Charging pump
19. Booster circulating pump
20. Motor driven four way valve
21. Alarm switch
22. External gas valve switch/burner function
23. DHW mode function switch
24. Fan (BG 2000-M / 201)
25. Gas valve (BG 2000-M / 201)
26. Gas pressure switch (BG 2000-M / 201) (optional)
27. Charging pump control relay



- B. Blue
- Bk. Black
- Br. Brown
- G. Grey
- Or. Orange
- R. Red
- V. Violet
- W. With
- Y./Gr. Yellow / Green

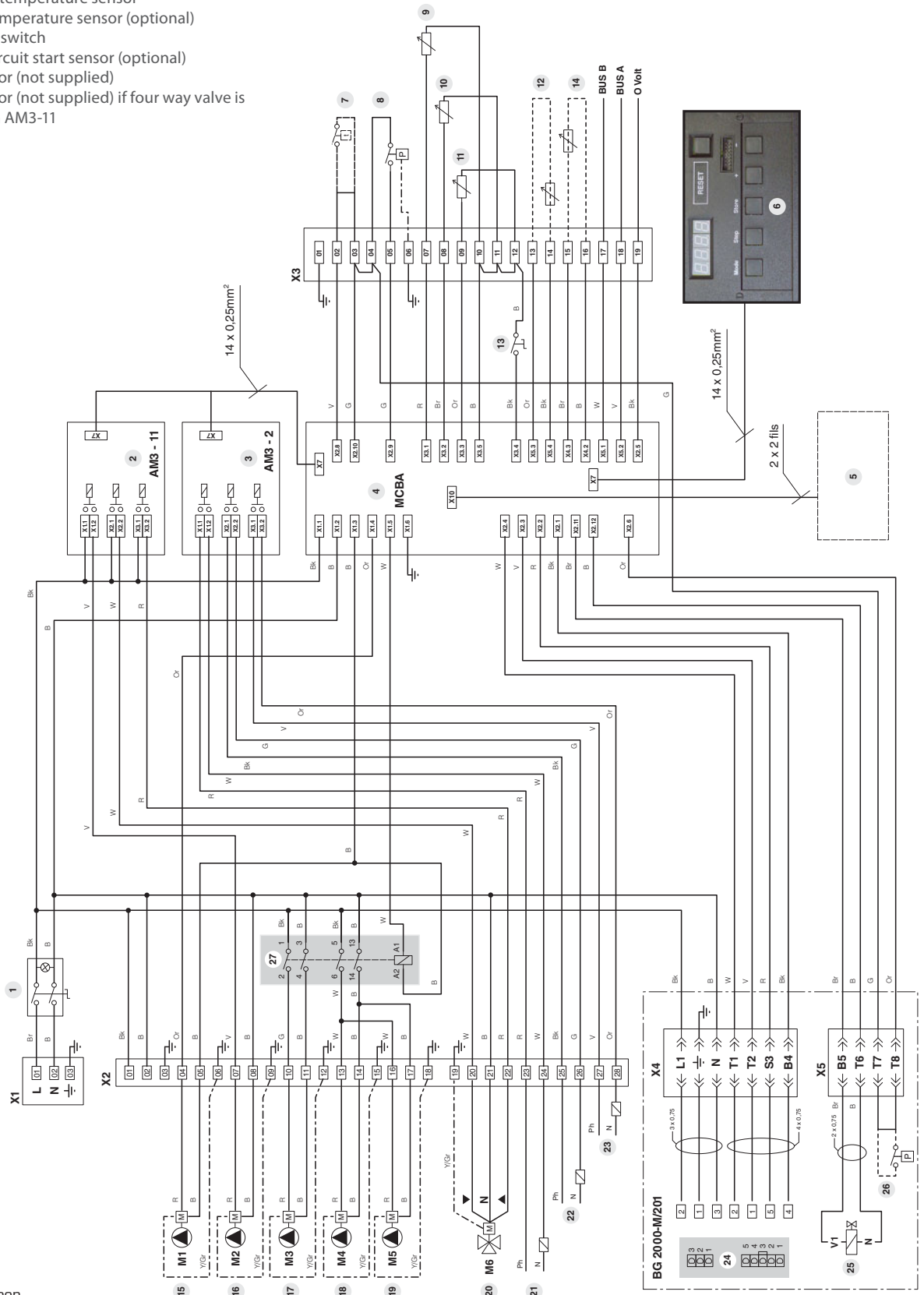

TECHNICAL CHARACTERISTICS

COMBUSTION CHARACTERISTICS

			HeatMaster® 71	HeatMaster® 101	HeatMaster® 201
Input (PCI)	Max	kW	69,9	107	220
	Min	kW	20	25	58,4
Output at 100% (80/60°C)	Max	kW	62,9	96,3	198
	Min	kW	18,4	23	45,8
Efficiency (max output) 80/60°C		%	90,2	90	91
Combustion efficiency at 100%		%	91,3	92	91,5
Gas connection [F]		Ø	3/4"	1"	1"1/4
Gas : G20 - 20 mbar I2E(S)* // I2H // I2Er // I2ELL // I2E // I2E(R)**					
Flow rate	Max	m³/h	7,4	11,3	25,4
	Min	m³/h	2,1	2,7	6,2
CO ₂	Max	%	9	9,2	9
	Min	%	8,9	8,1	9,1
Gas : G25 - 25 mbar I2L					
Flow rate	Max	m³/h	8,6	13,2	29,5
	Min	m³/h	2,5	3,1	7,2
CO ₂	Max	%	8,9	9,1	9
	Min	%	8,9	7,9	9,1
Gas : G31 - 30/37/50 mbar I3P					
Flow rate	Max	m³/h	2,9	4,5	9,8
	Min	m³/h	0,8	0,9	2,4
CO ₂	Max	%	10,6	10,4	10
	Min	%	10	8,7	10

HYDRAULIC CHARACTERISTICS

			HeatMaster® 71	HeatMaster® 101	HeatMaster® 201
Total capacity	L		239	320	641
Primary circuit capacity	L		108	124	241
DHW capacity	L		131	196	400
Heating Connection [F]	Ø		1"1/2	1"1/2	2"
DHW Connection [M]	Ø		1"	1"	2"
Primary circuit water pressure drop (ΔT = 20K)	mbar		46	83	240

DOMESTIC HOT WATER PERFORMANCE ***

OPERATING CONDITIONS AT 90°C			HeatMaster® 71	HeatMaster® 101	HeatMaster® 201
Peak flow at 40°C [ΔT = 30 K]	L/10'		646	898	1745
Peak flow at 45°C [ΔT = 35 K]	L/10'		543	774	1489
Peak flow at 40°C [ΔT = 30 K]	L/60'		2133	3168	6690
Peak flow at 45°C [ΔT = 35 K]	L/60'		1794	2676	5667
Constant flow at 40°C [ΔT = 30 K]	L/h		1835	2776	6117
Constant flow at 45°C [ΔT = 30 K]	L/h		1573	2379	5039
Heating time from 10 to 80°C	minutes		24	21	25

* HeatMaster 71

** HeatMaster® 101 and HeatMaster® 201

*** For DHW temperatures > 45°C (ΔT > 35K), please contact ACV



The temperature of the domestic hot water can be adjusted up to 90 °C in the boiler. However, the temperature of the domestic hot water at the drawing point must comply with local regulations. (E.g. in Belgium, the maximum DHW water temperature at a drawing point must be 75°C for boilers < 70 kW). For special applications, please contact ACV.



TECHNICAL CHARACTERISTICS

GAS CATEGORY

Natural gas categories	BE	FR	NL	LU - PL - RO	DE	AT - CH - CY - CZ - DK - EE - ES - GB GR - HR - IE - IT - LT - LV - NO - PT RO - SE - SI - SK - TR	HU
I 2E(S)B * [G20] 20 mbar – [G25] 25 mbar	●						
I 2E(R)B ** [G20] 20 mbar – [G25] 25 mbar	●						
I 2Er [G20] 20 mbar – [G25] 25 mbar		●					
I 2L [G25] 25 mbar			●				
I 2E [G20] 20 mbar				●	●		
I 2ELL [G20] 20 mbar – [G25] 20 mbar					●		
I 2H [G20] 20 mbar						●	
I 2HS [G20] 25 mbar							●

(* HeatMaster® 71 - (**) HeatMaster® 101 - 201

Propane gas categories	NL - RO	BE - CH - CZ - ES FR - GB - GR - HR IE - IT - LT - NL PL - PT - SI - SK	AT - CH DE - NL SK	CY - DK - EE - FR GB - HR - HU - IT LT - LU - NL - NO PL - RO - SE - SI SK - TR	AT - CH DE - FR HU - SK
I 3P [G31] 30 mbar	●				
I 3P [G31] 37 mbar		●			
I 3P [G31] 50 mbar			●		
I 3B/P *** [G30] 28 / 30 mbar				●	
I 3B/P *** [G30] 50 mbar					●

(***) HeatMaster® 201

MAXIMUM OPERATING CONDITIONS

Maximum Service Pressure (DHW tank full of water)

- Primary circuit 3 bar
- DHW circuit 10 bar

Maximum Test Pressure (DHW tank full of water)

- Primary circuit 4,5 bar
- DHW circuit 13 bar

Maximum Operating Conditions

- Maximum temperature of primary fluid 90 °C
- Minimum temperature of primary fluid 60 °C

Water Quality

- Chlorides ≤ 150 mg/l (304)
- 6 ≤ pH ≤ 8

TECHNICAL CHARACTERISTICS

BOILER ROOM

- make sure that all air vents are unobstructed at all times.
- do not store any flammable products in the boiler room.
- do not store any corrosive products, paint, solvents, salts, chloride products and other detergent products near the appliance.
- if you smell gas, do not switch on or off any lights, turn off the gas meter, ventilate the rooms and contact your installer.
- The base on which the boiler rests must be made of non-combustible materials.

CHIMNEY CONNECTION

- Chimney connection must comply with the applicable standards (NBN D51-003 in Belgium), and take into account the local requirements of the energy provider, the fire requirements and the regulation on "noise pollution".
- The flue pipe size must not be smaller than the size of the boiler outlet connection

B23 and B23P type chimney connection

The boiler is connected to the chimney by a metal pipe rising at an angle from the boiler to the chimney. A flue disconnection piece is required. It must be easily removable to give access to the flue pipes when performing boiler maintenance.



Due to the high efficiency of our boilers, the flue gases are released at low temperature. As a result, there is a risk of condensation in these flue gases, which could damage some flues. To avoid this risk, it is strongly recommended to line the chimney and prevent condensate to flow back into the boiler. Also allow for condensate removal. Please contact your installer for more information.

Minimum supply of fresh air into the boiler room

		Fresh air supply	
		High	Low (B23 and B23P)
HeatMaster® 71	cm ²	≥ 150	≥ 200
HeatMaster® 101	cm ²	≥ 200	≥ 320
HeatMaster® 201	cm ²	≥ 245	≥ 730

Dimensions of a B23 type chimney

		Height		
		5 m	10 m	15 m
HeatMaster® 71	Ø mm	189	159	150
HeatMaster® 101	Ø mm	234	178	150
HeatMaster® 201	Ø mm	350	300	270



Note:
Given that regulations vary from one country to another, the table above is given by way of indication only.

TYPE C CHIMNEY CONNECTION

- C13 : concentric horizontal connection
- C33(x): concentric vertical connection
- C53(x): parallel chimney connection
- C63(x): concentric vertical connection without terminal (Only in Germany and Luxemburg)

The total load loss (air inlet + flue gas outlet) cannot exceed the value (Pa) indicated in the table below showing the pressure drops for the various components.

A = fresh air supply B = flue gas	HeatMaster® 71		HeatMaster® 101		HeatMaster® 201	
	A	B	A	B	A	B
	Ø 80	Ø 150	Ø 100	Ø 150	Ø 150	Ø 250
1m straight pipe	6	3	6	4	3	3
90° elbow	15	5	15	10	14	10
45° elbow	6	1	6	2	6	-
Condensate recovery container	-	2	-	4	-	5
Terminal	20	10	10	10	22	20
Maximum pressure drop. (Pa)	100		100		130	

This table is based on ACV equipment and cannot be applied elsewhere.



**In concentric connection, the total length of the connection is limited to 6 metres.
In parallel connection, the total length of the connection is limited to 12 metres.**

A condensate recovery device must be provided for in the boiler flue outlet, so as to avoid flue condensate entering the boiler.

To avoid condensation water flowing from the terminal, all horizontal pipe lengths must fall back towards the boiler.

CHIMNEY CONNECTION CHARACTERISTICS

		HeatMaster® 71	HeatMaster® 101	HeatMaster® 201
Volume of the combustion chamber	m ³	0,068	0,068	0,140
Mass flow rate of combustion products - [G20/G25]	kg/h	115	173	394
Mass flow rate of combustion products - [G31]	kg/h	114	177	414
Flue pipe diameter	mm	150	150	250
Net temperature	°C	193	174	187
B23		✓	✓	✓
B23P		✓	✓	✓
C13		✓	✓	
C33(x)		✓	✓	
C53(x)		✓	✓	✓

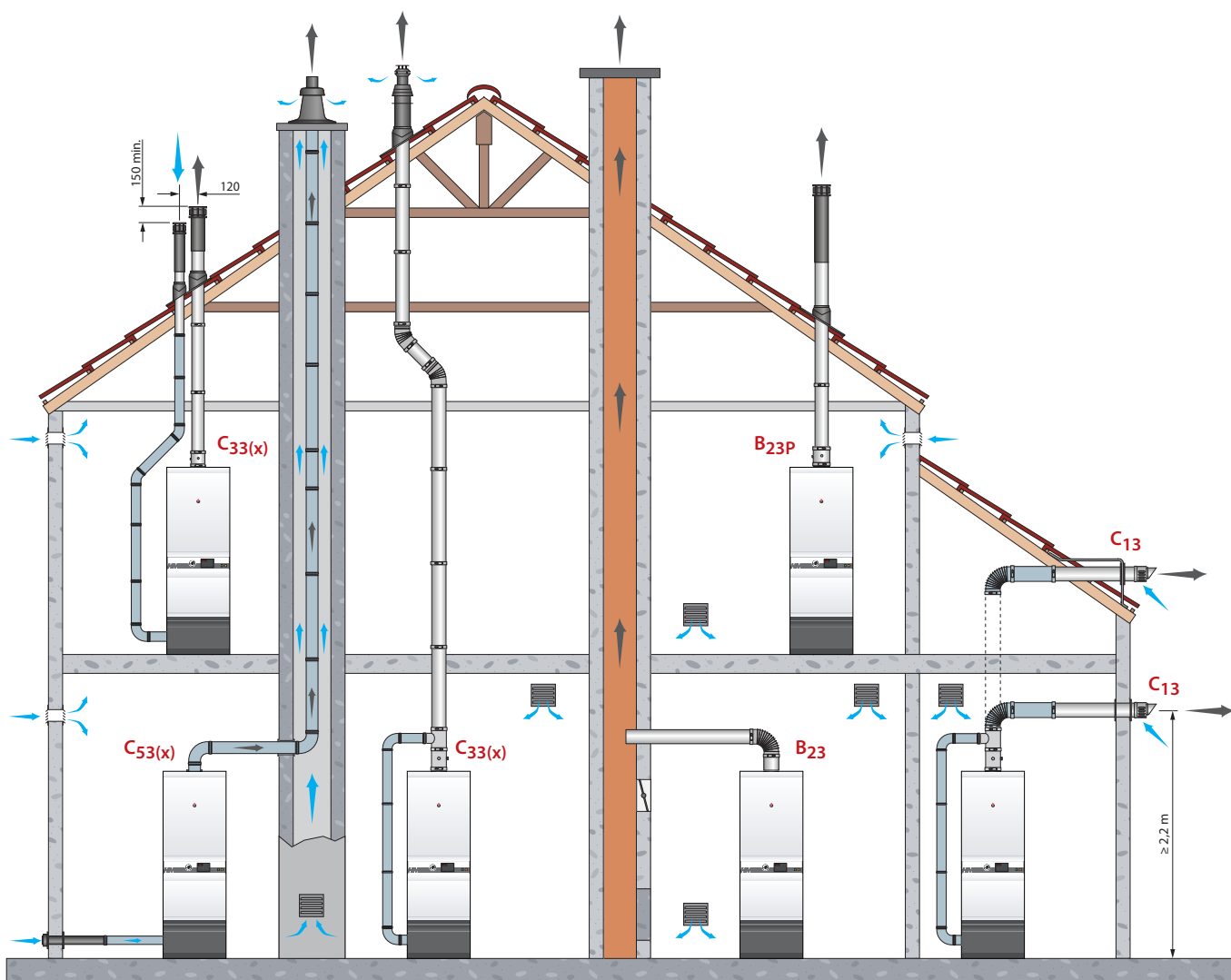

BURNER CHARACTERISTICS

AIR/GAS PRE-MIX BURNERS ACV BG 2000-M

DESCRIPTION

The power continually adjusts itself according to demand; this greatly improves the operating efficiency for heating and hot water. The burner tube is covered with a metal fibre (NIT), which, besides its remarkable heat exchange capacity, guarantees longer burner life.

The burner's main components are:

- a variable speed fan
- an automatic ignition and flame detection system
- a gas valve and venturi tube set specially developed for low NOx pre-mix air/gas burners

Gas pressure in the gas valve outlet is kept equal to the absolute air pressure in the venturi tube inlet, corrected by the offset adjustment on the regulator.

The fan pulls the combustion air through the venturi tube whose neck is connected to the gas valve outlet. The pressure differential created at the neck of the venturi tube by the airflow rate induces gas intake proportional to its level (the larger the air flow rate, the greater the differential and there is a larger quantity of gas intake). The air/gas combination is then introduced into the burner via the fan.

This principle guarantees safe and quiet operation:

- In the event of low air flow, the differential across the venturi tube falls, the gas flow rate diminishes, the flame extinguishes and the gas valve closes: the burner is then in safety mode.
- In the event of flue blockage or restriction, the air flow rate falls, and there are then the same reactions as those described before causing burner stop in safety mode.
- The BG 2000-M burner installed on HeatMaster® models is controlled by a MCBA Honeywell controller which manages both the burner safety function and its modulation according to temperature.

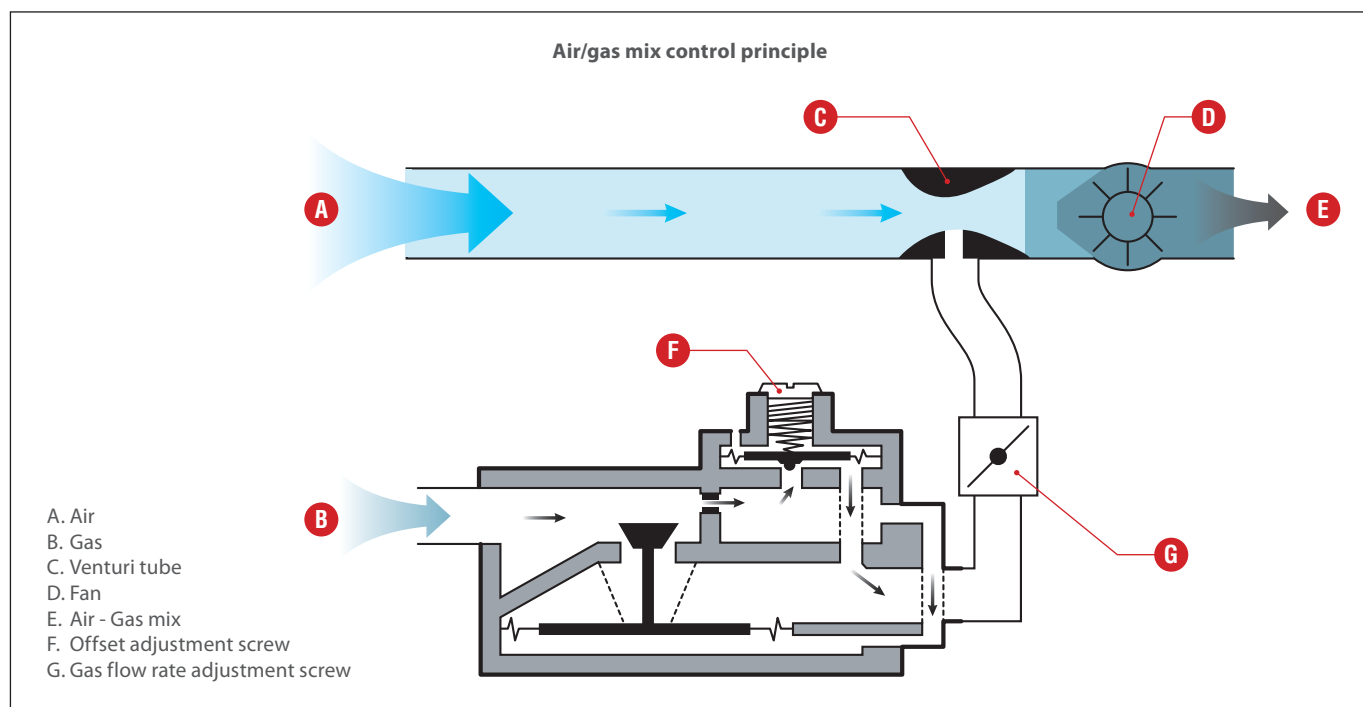
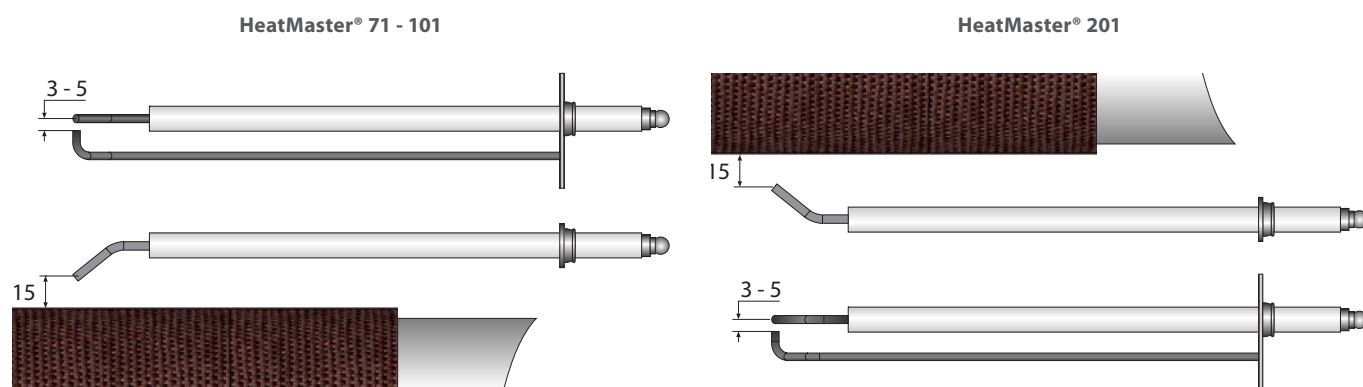

BURNER CHARACTERISTICS

1. Burner tube
2. Ignition and ionisation electrode
3. Gas valve
4. Gas connection
5. Flame sight glass
6. Fan
7. Venturi tube

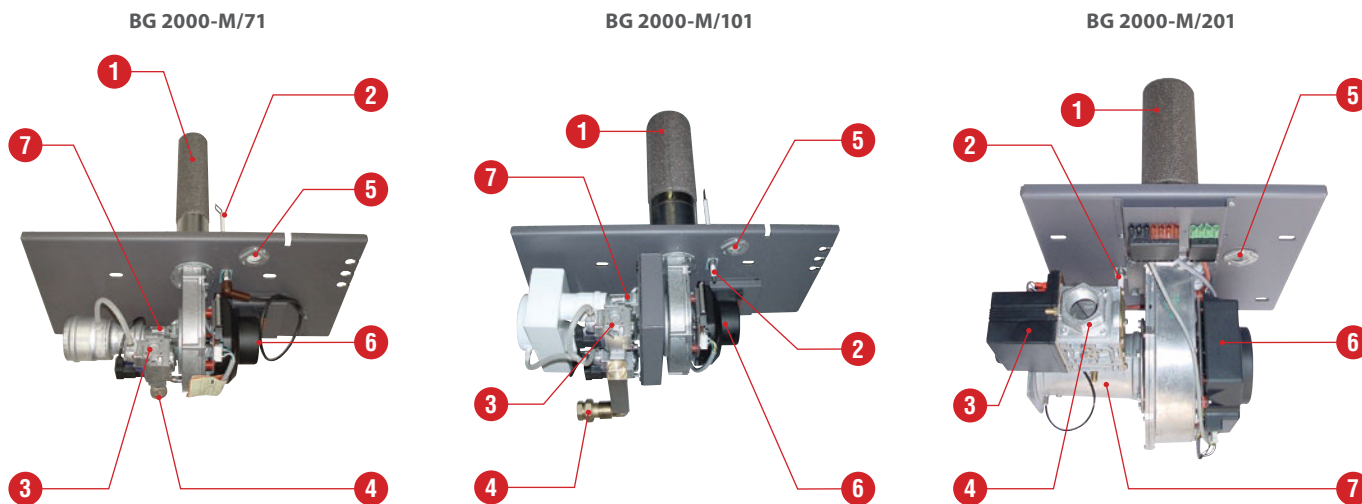

BURNER ADJUSTMENT

When the burner operates at full power, the CO₂ must be 8.8% to 9.2% (natural gas) or 10.5% to 10.6% (propane).

If necessary adjust the CO₂ by turning the screw in the clockwise direction to reduce and the anti-clockwise to increase. (see photo)



The BG 2000-M burners are pre-adjusted for natural gas in the factory.

Conversion to propane:



Prohibited in Belgium.

BG 2000-M/71 - 101

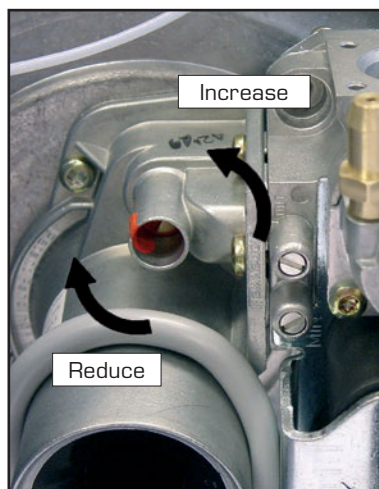

BG 2000-M/201

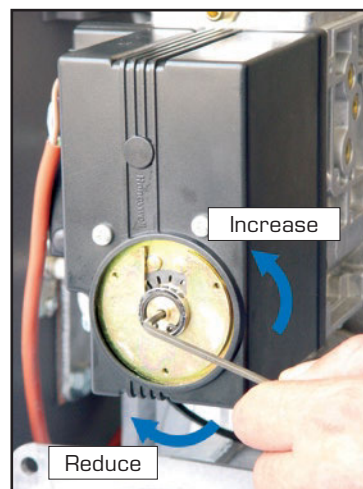

INSTALLATION

PACKAGE CONTENTS OF THE HEATMASTER® 71 - 101

The appliances are delivered tested and packaged on a wooden support, protected by anti-shock corner pieces and wrapped in a plastic film.

At product reception and after removal of packaging, check the package contents and that the appliance is free of damages.

Contents

- A HeatMaster® 71 / 101 boiler
- Installation, operation and maintenance instructions
- A hydraulic kit, comprised of:
 - A primary safety valve Ø 1/2" F
 - A reducer Ø 1/4" F - Ø 1/8" M
 - A check-valve Ø 1/4" F - Ø 1/4" M
 - A draining valve Ø 1/2" M

BOILER PREPARATION

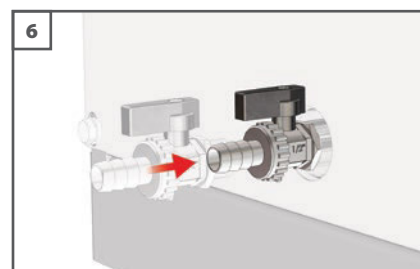
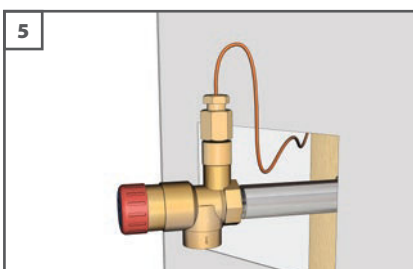
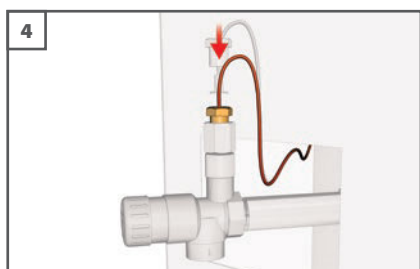
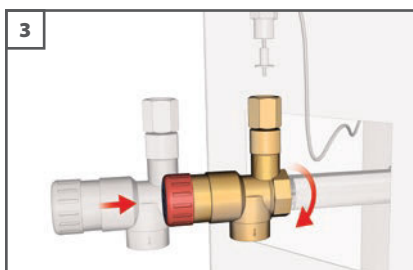
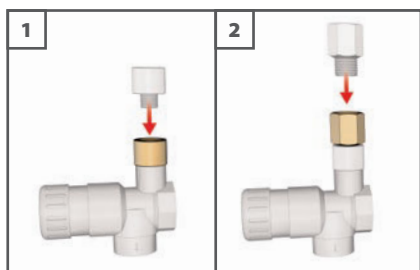

PACKAGE CONTENTS OF THE HEATMASTER® 201

The appliances are delivered in 4 packages, tested and packaged separately on a wooden support, protected by anti-shock corner pieces and wrapped in a plastic film.

At product reception and after removal of packaging, check the package contents and that the appliances are free of damages..

Package contents N° 1 - [516 kg]

- A **HeatMaster® 201** boiler
- A installation, operation and maintenance instructions
- A MCBA-5 System Control manual
- A hydraulic kit, comprised of:
 - A primary safety valve Ø 3/4" F
 - A stainless steel pipe Ø 1"
 - A brass elbow union 90° - Ø 1"
 - A draining valve Ø 3/4" M
 - Silicone hose Ø 12x16 mm of 2,7 meters

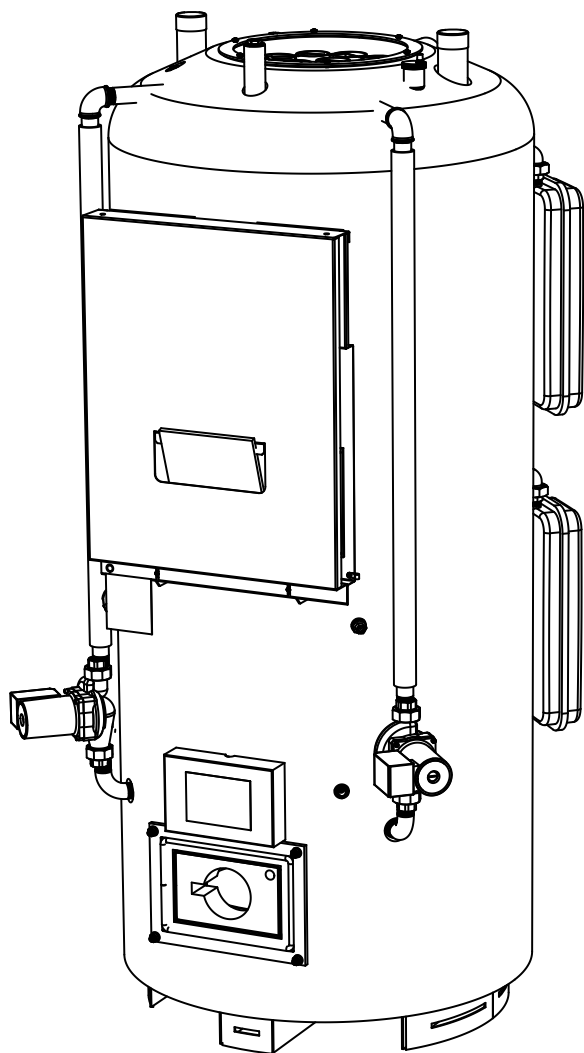

Package contents N° 2 - [103 kg]

- A steel casing
- A casing assembly manual

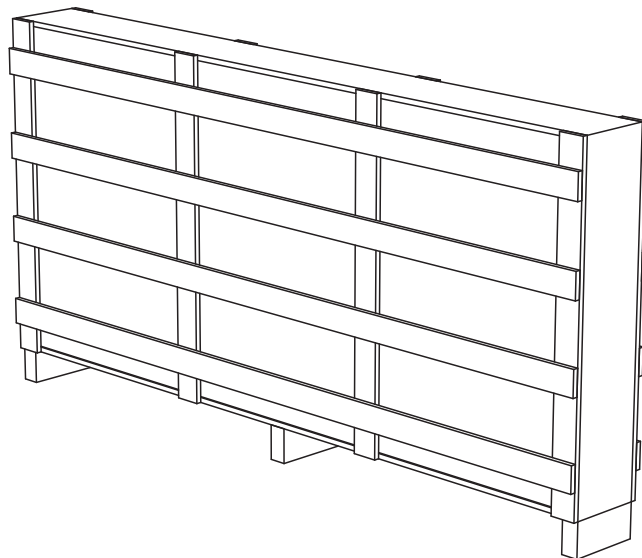

Package contents N° 3 - [10 kg]

- A chimney reduction with horizontal outlet
- A gasket for the flue reduction collar



Package contents N° 4 - [29 kg]

- A BG 2000/M 201 burner.
- A burner cover
- A technical instruction manual

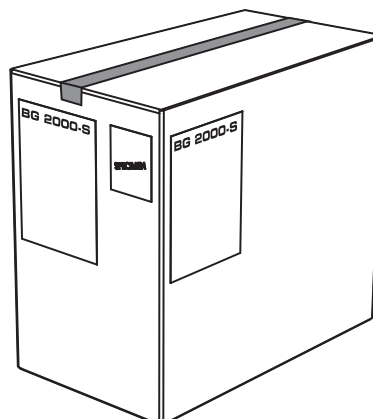

DHW CONNECTION



The DHW tank must be pressurized before putting the primary circuit (heating) under pressure.

The HeatMaster® boiler can be connected directly to the DHW circuit.

Flush the system before connecting the domestic hot water circuit.

The installation must be fitted with an approved safety group, comprised of a 7 bar safety valve, a check valve and a shut-off valve.

During the heating process, the domestic hot water expands and the pressure increases. As soon as the pressure exceeds the safety valve setting, the valve opens and discharges a small quantity of water. Using a hot water expansion vessel (2 liters at least) will prevent this phenomenon and reduce the water hammer effect.



The hot water output may reach temperatures in excess of 60°C, which can cause burns.
ACV therefore recommends that you install a thermostatic mixing valve immediately after the appliance outlet.



If stop valves are used in the domestic hot water system, they can cause pressure changes when closed.
Use devices designed to reduce water hammer effect to avoid this phenomenon.



If there is a risk of low pressure in the hot water circuit (installation of HeatMaster® on the roof of a building), it is essential to install a vacuum breaker device onto the cold water supply.

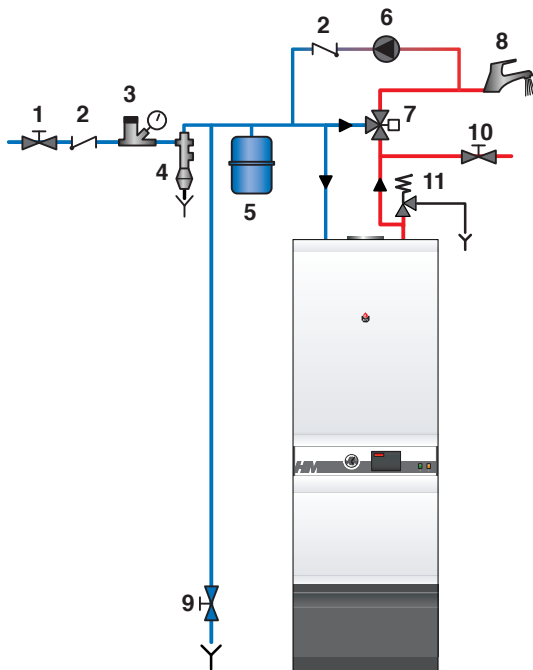

1. Cold water supply valve
2. Check valve
3. Pressure reducing valve
4. Domestic hot water safety valve set at 7 bar
5. DHW circuit expansion vessel
6. DHW secondary pump (if fitted)
7. Thermostatic mixing valve
8. Draw-off tap
9. Draining valve
10. Stop valve for cleaning
11. Temperature relief valve (UK only)

EXAMPLE OF PARALLEL CONNECTION

Recommended for applications with a high constant flow.

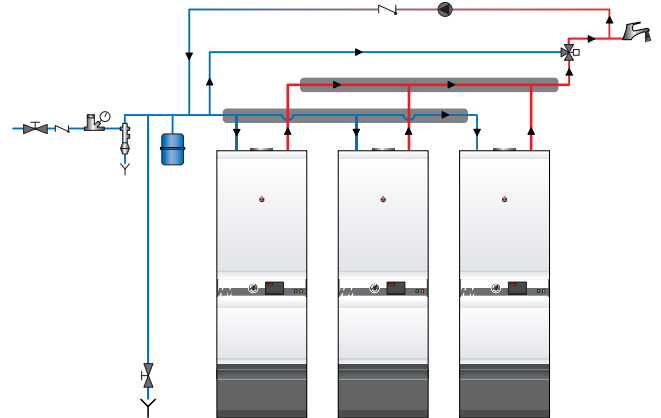

EXAMPLE OF SERIES CONNECTION

Preferable for high-temperature applications with up to 3 units

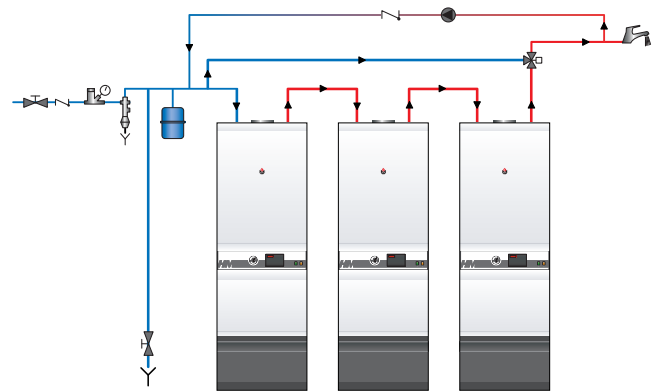

EXAMPLE OF HEATING + STORAGE CONNECTION

Recommended for applications requiring a high peak flow.

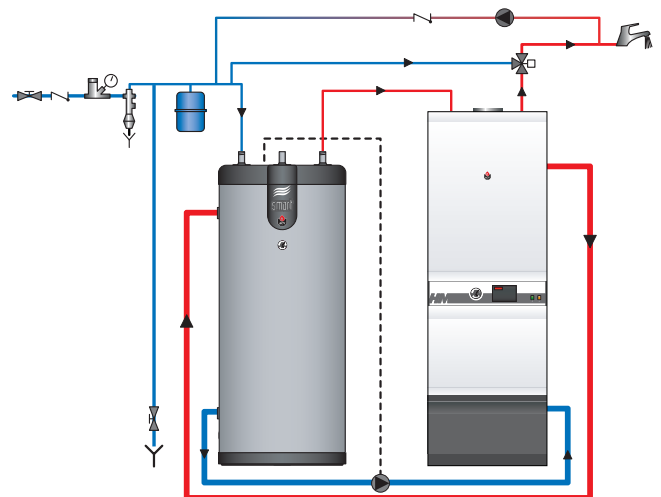

HEATING CONNECTION



The DHW tank must be pressurized before putting the primary circuit (heating) under pressure.

Two couplings are installed at the back of the **HeatMaster®**, that can be used to connect a central heating circuit.
Connecting a heating system may reduce the domestic hot water performance.

EXPANSION VESSEL

The **HeatMaster®** 71 and 101 are fitted with two 10 litre expansion vessels.

The **HeatMaster®** 201 models are equipped with four 8 litre expansion vessels.

The expansion vessels are sized only for the "hot water" function. In the case of primary circuit connection, it is necessary to calculate the expansion capacity necessary for the total heating system volume (Refer to the expansion vessel manufacturer's technical instructions for a broader explanation).



The pressure of the HeatMaster® expansion tanks must be adjusted to the same pressure as the heating circuit expansion tanks.



WARNING

The primary safety valve is supplied with a plastic tube connected to discharge outlet - this is for test purposes only and should be removed.

The safety valve should be connected to the sewer using a metallic pipe, e.g. copper.

1. 4-way mixing valve
2. Heating pump
3. Check valve
4. Heating circuit isolating valves
5. Safety valve set at 3 bar with pressure gauge
6. Expansion vessel
7. Drain valve
8. Primary circuit filling valve
9. Controller
10. Contact sensor
11. Room thermostat
12. Outdoor temperature sensor

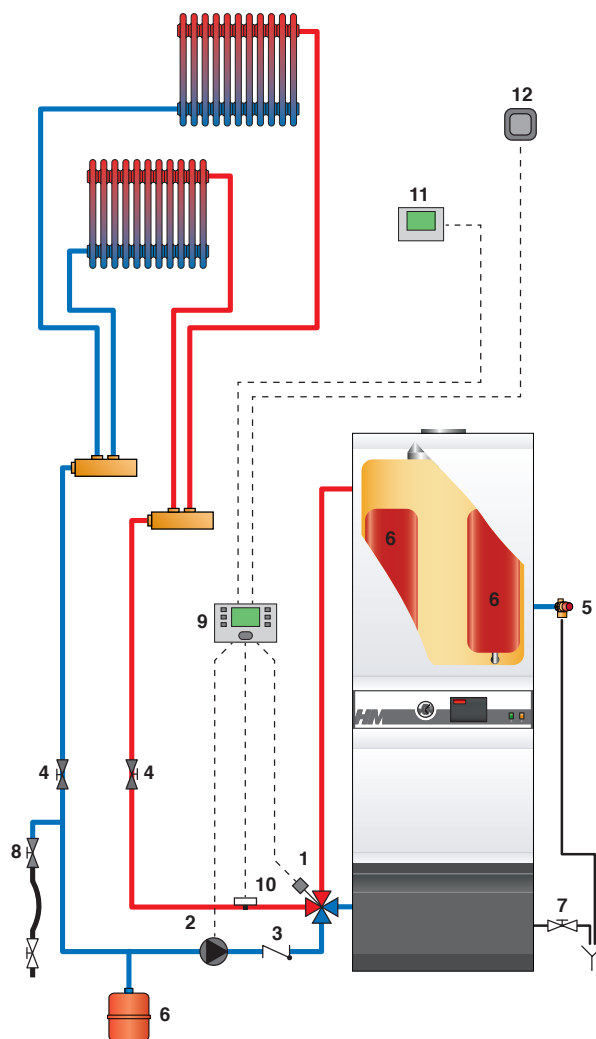

GAS CONNECTION

- The **HeatMaster®** 71/101/201 boilers are equipped with a BG 2000-M 71/101/201 burner with a gas \varnothing 3/4" - 1" and 1 1/4" connection [F] to connect a gas supply valve.
- The gas connections must comply with all applicable standards (in Belgium: NBN D51-003).
- If there is a risk of dirt stemming from the gas network, place a gas filter upstream of the connection.
- Purge the gas pipe and carefully check that there are no leaks on the boiler's internal and external pipes.
- Check the system's gas pressure. Please refer to the technical data table.
- Check the gas pressure and consumption when commissioning the appliance.

STARTING UP

FILLING THE DOMESTIC HOT WATER AND HEATING CIRCUITS



IMPORTANT

Before pressurizing the central heating circuit, you should first put the domestic hot water tank under pressure.

FILLING THE DOMESTIC HOT WATER CIRCUIT

1. Open the filling valve (1) and the drawoff tap (2).
2. When water flows out of the tap, the hot water tank is full and the drawoff tap (2) should be closed.

PRELIMINARY FILLING OF THE HEATING CIRCUIT

1. Open the stop valves (A).
2. Make sure that the draining valve (D) is fully closed.
3. Open the filling valves (B and C) to start filling the primary circuit with mains water until you reach an approximate pressure of 1,5 bar in the system.
4. Bleed the boiler and the whole system using the automatic air bleed valve located on top of the appliance.

STARTING UP THE BOILER

STARTING THE BURNER

1. Set the boiler master switch on "ON" and the summer/winter switch on the "❄️" symbol.
2. Rotate the boiler control thermostat clockwise to generate a heat demand.
3. Possibly increase the set temperature of the room thermostat, if installed.

ADJUSTING THE COMBUSTION

1. Refer to the starting up instructions detailed in the technical manual of the burner.
2. Adjust CO₂ as described in the Starting up paragraph of the burner.
3. Check temperatures and CO level.

BLEEDING THE HEATING CIRCUIT

1. Bleed the heating circuit again to restore a 1.5 bar pressure.
2. Repeat the sequence until complete evacuation of the air contained in the circuit.

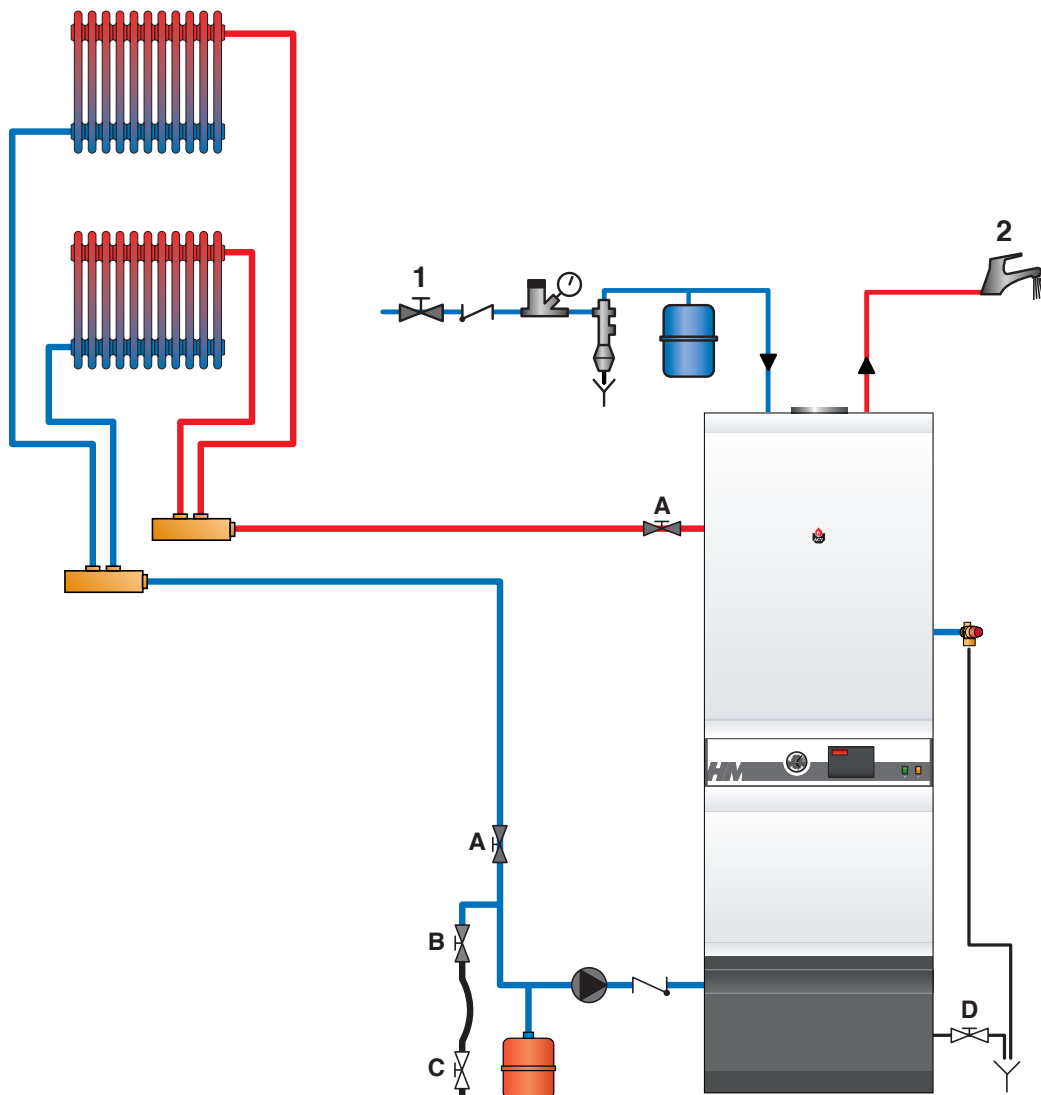

ANNUAL MAINTENANCE

ACV recommends the boilers should be serviced at least once a year. Maintenance and the burner control must be performed by a qualified engineer.

More frequent servicing may be required depending on boiler use. If this is the case, consult your installer for advice.

BOILER MAINTENANCE

1. Put the master switch on the control panel on "OFF" and isolate power supply to the unit.
2. Turn off the gas or oil supply to the boiler.

• Vertical flue gas outlet reduction:

3. Disengage and remove the flue connection to the boiler
4. Remove the flue reducer by un-tightening the nuts.
5. Extract the turbulators from the flue gas tubes for cleaning.
6. Dismantle the fire door and withdraw the burner.
7. Brush the flue gas tubes.
8. Clean the combustion chamber and the burner.
9. Replace the turbulators, chimney reduction and flue connection, and check that the seal on the flue reducer is in good condition. Replace the seal if necessary.

• Horizontal flue gas outlet reduction:

3. Remove the cover from the flue reducer by un-tightening the nuts.
4. Extract the turbulators from the flue gas tubes for cleaning.
5. Dismantle the fire door and withdraw the burner.
6. Brush the flue gas tubes.
7. Clean the combustion chamber and the burner.
8. Replace the turbulators, chimney reduction and flue connection, and check that the seal on the flue reducer is in good condition. Replace the seal if necessary.

MAINTENANCE OF THE SAFETY DEVICES

- Check that all thermostats and safety devices are working properly.
- Test the safety valves on the central heating and hot water circuits.

BURNER MAINTENANCE

- Check that the insulation and seal of the fire door are in good condition - replace them if necessary.
- Check and clean the burner and the electrodes. Replace the electrodes if necessary (once a year for normal use).
- Check that the safety valves are in good working order.
- Check the combustion (CO_2 , CO and burner pressure).

DRAINING THE BOILER



Water flowing out of the drain valve may be extremely hot and could cause severe scalding. Keep people away from discharge of hot water.

DRAINING THE HEATING CIRCUIT

1. Put the master switch of the control panel on OFF, isolate the external electrical supply and turn off the gas or oil supply to the boiler.
2. Close the isolating valves (4) or put manually the 4-way mixing valve (1) on "0".
3. Connect a hose to the draining valve (7).
4. Open the draining valve to empty the primary circuit.

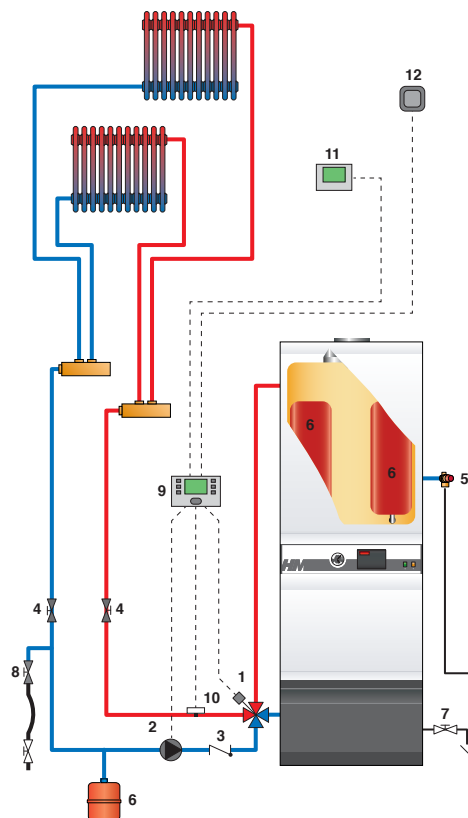

DRAINING THE DHW CIRCUIT

1. Put the master switch of the control panel on OFF, isolate the external electrical supply and turn off the gas or oil supply to the boiler.
2. Release the pressure in the heating circuit until the pressure gauge indicates 0 bar.
3. Close valves (1) and (8).
4. Open valves (9) and (10) (first 9 then 10).
5. Allow the drained water to flow into the sewer.



For the circuit to be drained, the draining valve (9) must be located at ground level.

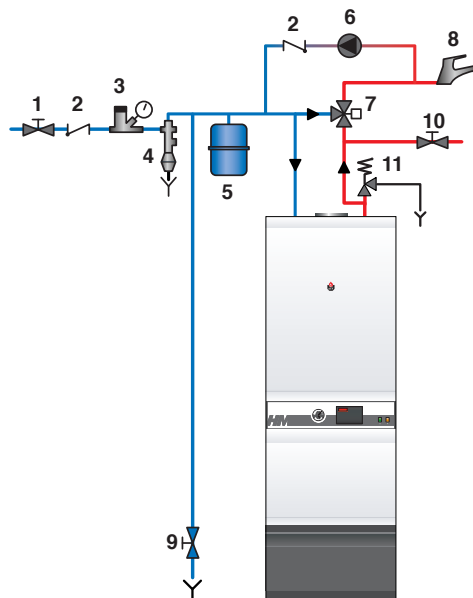



excellence in hot water



DECLARATION OF CONFORMITY - CE

1/1

Name and address of manufacturer: **ACV International SA / NV**
Kerkplein, 39
B-1601 Ruisbroek

Description of product type: **Low-temperature boiler**

Models:	HeatMaster 71	HeatMaster 101	HeatMaster 201
CE #:	0461BN0684	0461BN0650	0461BO0767

We declare hereby that the appliance specified above is conform to the type model described in the CE certificate of conformity to the following directives:

Directives	Description	Date
92/42/EEC	Efficiency Requirements Directive	20.03.2008
2009-142-CE	Gas Appliances Directive	30.10.2009
2006/95/EC	Voltage Limits Directive	12.12.2006
2004/108/EC	Electromagnetic Compatibility Directive	15.12.2004

We declare under our sole responsibility that the product **HeatMaster** complies with the following standards:

Standards	HeatMaster 71	HeatMaster 101	HeatMaster 201
EN 303-7		✓	
EN 483	✓		
EN 15502-1			✓
EN 15502-2-1			✓
EN 60335-2-102	✓	✓	✓
EN 55014-1	✓	✓	✓
EN 55014-2	✓	✓	✓
EN 61000-3-2	✓	✓	✓
EN 61000-3-3	✓	✓	✓

Ruisbroek, 11/02/14

Date

Director R & D
 Marco Croon



EN
FR
NL
ES
IT
DE
PL
RU

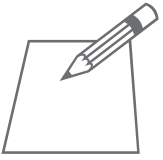

A series of horizontal dotted lines for writing, starting from the top right of the notepad illustration and extending across the width of the page.



A series of horizontal dotted lines for writing, starting from the top right of the notepad illustration and extending across the width of the page.