

INSTALLATION, OPERATION AND MAINTENANCE INSTRUCTIONS

HeatMaster®

30 N

60 N

70 N

100 N



excellence in hot water

TABLE OF CONTENTS

WARNINGS

Who should read these Instructions	3
Symbols	3
Recommendations	3
Warnings	3

USER'S GUIDE

Using the Boiler	4
Burner safety mechanism	5
Burner Troubleshooting	5

APPLIANCE DESCRIPTION

TECHNICAL CHARACTERISTICS

Dimensions	8
Boiler Clearance	9
Burner Chamber Door	9
Combustion Characteristics	10
Hydraulic Characteristics	10
DHW Performance	10
Maximum Operating Conditions	11
Chimney Connection Characteristics	11
Boiler Room	11
Chimney Connection	11
Type C Chimney Connection	12
Electrical Characteristics	13

INSTALLATION

Package Contents	14
Boiler Preparation	14
DHW Connection	16
Heating Connection	17

STARTING UP

Filling the DHW and Heating Circuits	18
Starting up the Boiler	18
Bleeding the Heating Circuit	18

MAINTENANCE

Annual Maintenance	19
Boiler Maintenance	19
Maintenance of the Safety devices	19
Burner Maintenance	19
Draining the Boiler	19

DECLARATION OF CONFORMITY - EC 20

SPARE PARTS

www.acv.com

CERTIFICATION

The appliances bear the "CE" mark, in accordance with the standards in force in the various countries [European Directives 92/42/EEC "Efficiency", 2009/142/EC "Gas Appliances"]. These appliances also bear the Belgian gas boiler quality labels "HR+" [gas boiler] and "OPTIMAZ" [oil boiler].



Certified ISO 9001 quality system



664Y5400-B

WARNINGS

WHO SHOULD READ THESE INSTRUCTIONS

The manual should be read by:

- The specifying engineer
- The user
- The installer
- The maintenance technician

SYMBOLS

The following symbols are used in this manual:



Essential instruction for the correct operation of the installation



Essential instruction for the safety of persons and the environment



Danger of electrocution



Risk of scalding

RECOMMENDATIONS



- Please carefully read this manual before installing and starting up the boiler.
- It is prohibited to carry out any modifications to the inside of the appliance without the manufacturer's prior and written agreement.
- The product must be installed and serviced by an approved and qualified engineer, in accordance with applicable standards and regulations.
- Failure to comply with the operation instructions and test procedures can result in personal injury or a risk of environmental pollution.
- To guarantee safe and correct operation of the appliance, it is important to have it serviced and maintained every year by an approved installer or maintenance contractor.
- In case of anomaly, please call your service engineer.
- In spite of the strict quality standards that ACV applies to its appliances during production, inspection and transport, faults may occur. Please immediately notify your approved installer of any faults.
- The defective parts may only be replaced by genuine factory parts. A list of the spare parts and their ACV reference number is provided at the following address: www.acv.com.
- The gas burners are factory preset for use with natural gas [equivalent to G20].
- Specific regulation applicable in Belgium [for the gas burners]: The CO₂ level, the air and gas flows and the gas/air ratio are factory preset. Any field adjustment of those settings is not allowed in Belgium



- Before carrying out any work on the boiler, it is important to isolate the electrical supply to the unit.
- The user must not attempt to gain access to the components inside the boiler or the control panel.
- This appliance is not intended for use by persons (including children) with reduced physical, sensory or mental capabilities, or lack of experience and knowledge, unless supervised or unless they have been given instruction concerning the use of the appliance by a person responsible for their safety.

WARNINGS

If you smell gas:

- Immediately isolate the gas supply.
- Open windows and doors to ventilate the area.
- Do not use any electrical appliances and do not operate any switches.
- Immediately notify your gas supplier and/or your installer.

This manual is part of the items delivered with the appliance and must be given to the user and stored in a safe place!

An approved installer must carry out the installation, starting up, maintenance and repair of the system, in accordance with current standards in force.

The manufacturer declines all liability for any damage caused as a result of incorrect installation or in the event of the use of appliances or accessories that are not specified by the manufacturer.



The manufacturer reserves the right to change the technical characteristics and features of its products without prior notice.



The availability of certain models as well as their accessories may vary according to markets.

USING THE BOILER



Make sure to have your installation inspected and maintained, if required, at least once a year by an approved and qualified engineer. More frequent servicing may be required depending on boiler use. If this is the case, consult your installer for advice.

Starting the burner:

In normal operation, the burner starts automatically as soon as the boiler temperature drops below the set temperature.

GETTING FAMILIAR WITH THE CONTROL PANEL

The user must not attempt to gain access to the components inside the control panel.

• Master switch

Is used to turn the **HeatMaster®** on or off.

• Control thermostat - 60-90 °C

When using the **HeatMaster®** as a hot water generator only, the temperature can be set between 60 °C and 90 °C. If the **HeatMaster®** is used for both domestic hot water (DHW) and central heating, the control thermostat would normally be set at 80 °C to achieve optimum operating conditions.

• Summer/winter switch

Is used to turn the heating pump (if fitted) on or off.

• Manual reset high limit thermostat

If the boiler temperature exceeds 103 °C, this safety device will activate and the high temperature indicator will light up. To reset - first allow the boiler to cool to below 60 °C, unscrew the cap and press the reset button using a pencil or similar pointed device, then reinstall the cap. If the fault persists, turn the boiler off and call a service engineer.

• Daily timer

Allows the **HeatMaster®** to be turned on and off at specific moments of the day and operates on a 24 hour sequence. A series of white tabs are set around the timer, each tab corresponding to a 15 minute switching period. To set the timer, simply push outwards the number of tabs required for ON period.

Remember: Tab in = **HeatMaster®** OFF
 Tab out = **HeatMaster®** ON

• Temperature and pressure gauge

This gauge indicates both the temperature of the **HeatMaster®** and the pressure within the primary circuit. The temperature should not exceed 90 °C - if it does, switch the boiler off and check the thermostat setting. If the fault persists, call an engineer. The pressure should not fall below 1 bar, if it does, please see the 'Heating System Pressure' paragraph further in this section.

• Low primary water pressure indicator

If this indicator lights up, the primary circuit of the **HeatMaster®** requires topping up with water. Please see the 'Heating System Pressure' paragraph later in this section.

HeatMaster® 30 N and 60 N Control Panel

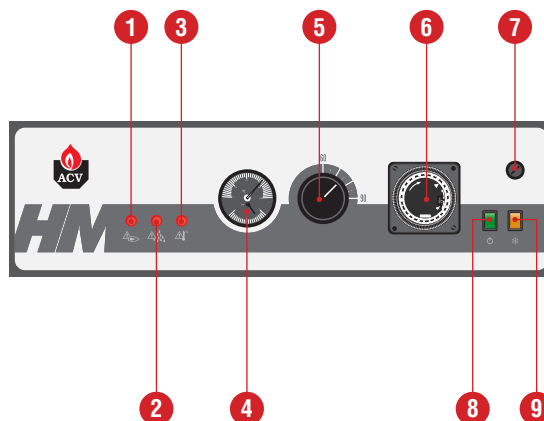

1. Burner safety cutout warning indicator
2. Low primary water pressure indicator
3. High limit thermostat indicator
4. Temperature and pressure gauge
5. Control thermostat
6. Daily timer
7. Manual reset high limit thermostat
8. Master switch
9. Summer/winter switch

HeatMaster® 70 N and 100 N Control Panel

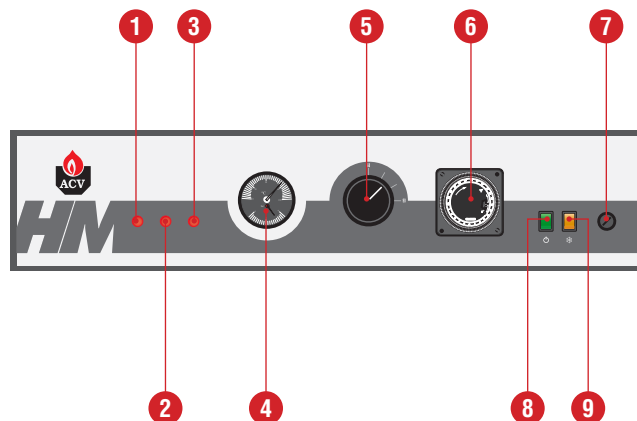

Heating System Pressure



From time to time you may need to top up the heating circuit water level to get the required pressure in the system. The circuit pressure is indicated by the combined temperature and pressure gauge on the boiler control panel.

The minimum pressure when the boiler is cold should be 1 bar. The precise operating pressure required depends on the height of the building and your installer will have informed you of this value at the time of installation (see Starting up section - Filling the DHW and heating circuits).

If the pressure falls below 1 bar, the boiler water pressure switch will turn the boiler off until the pressure is restored

To restore the pressure, top up the heating circuit with water by opening the filling valve (A) of the boiler primary circuit and allow the system to fill. Once the pressure gauge of the boiler control panel indicates the required pressure, close the filling valve.

Safety valves

If water discharges from any of the safety valves, turn the boiler off and call a service engineer.

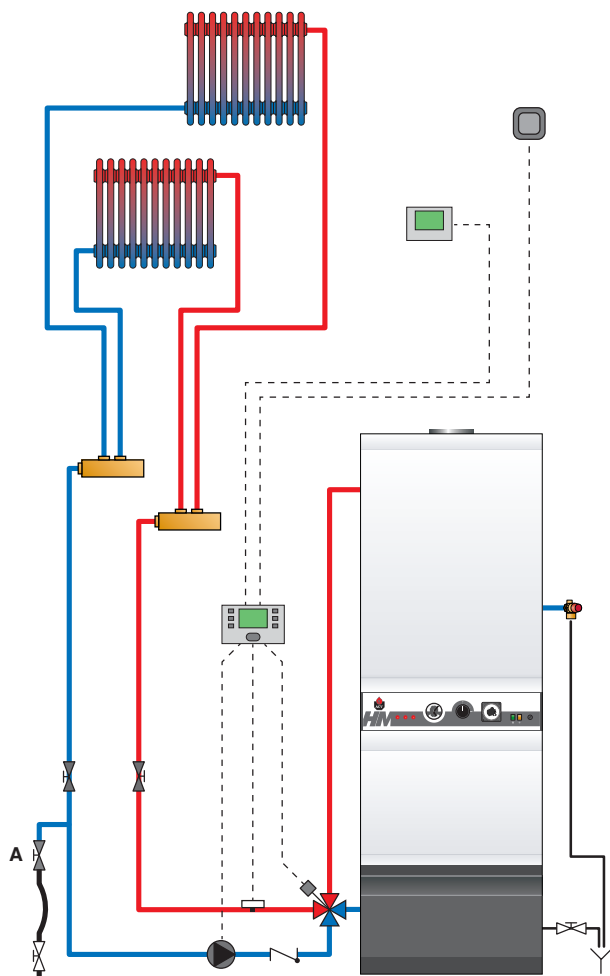

BURNER SAFETY MECHANISM

SAFETY CUTOFF OF THE OIL OR GAS BURNER

- **HeatMaster® 30 N**
 - ➔ The safety cutoff indicator is located on the burner and on the control panel.

The red warning light indicates an operating fault. Wait 5 min before resetting the burner. To reset: press the button located on the burner.

If the burner does not restart, call a service engineer after ensuring the fault is not due to a power failure or low oil level in the tank.



RESETTING THE BG 2000 AIR/GAS PREMIX BURNER

- **HeatMaster® 30 N** with BG 2000-S/35
 - **HeatMaster® 60 N** with BG 2000-S/60
 - **HeatMaster® 70 N** with BG 2000-S/70
 - **HeatMaster® 100 N** with BG 2000-S/100
 - ➔ The safety cutoff indicator is located on the burner and on the control panel.
1. Remove the burner cover.
 2. Press the red button to restart the burner.
 3. If the burner works properly, reinstall the cover.
 4. If the the fault persists, call a service engineer.

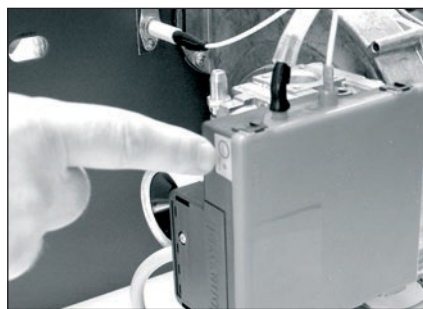

BURNER TROUBLESHOOTING

For all burners, please refer to the relevant servicing and troubleshooting instructions in the technical manual of your burner.

APPLIANCE DESCRIPTION

Description HeatMaster® 30 N / 60 N

1. Automatic air bleed valve
2. Cold water inlet
3. Dry well
4. Hard polyurethane foam insulation
5. Casing front panel
6. Primary expansion vessel
7. Control panel
8. Charging pump
9. Burner cover
10. Burner chamber plate insulation
11. Top cover
12. Flue reduction collar
13. Heating circuit outlet
14. Domestic hot water outlet
15. Stainless steel "Tank in Tank" hot water production tank
16. Flue pipes and turbulators
17. Primary circuit
18. Heating circuit return
19. Combustion chamber
20. Oil burner chamber plate
21. Draining valve
22. Gasket for the flue reduction collar

- A. Automatic reset high limit thermostat
- B. Manual reset high limit thermostat
- C. Low water pressure switch
- D. Primary circuit safety valve
- E. Control thermostat

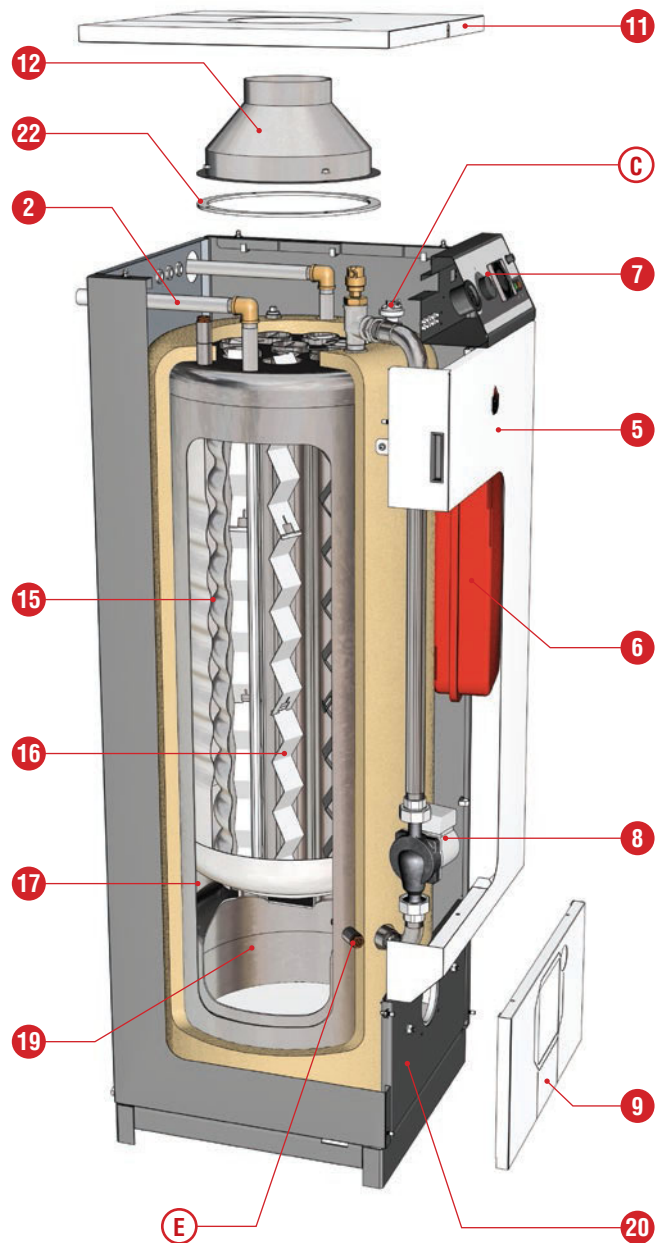
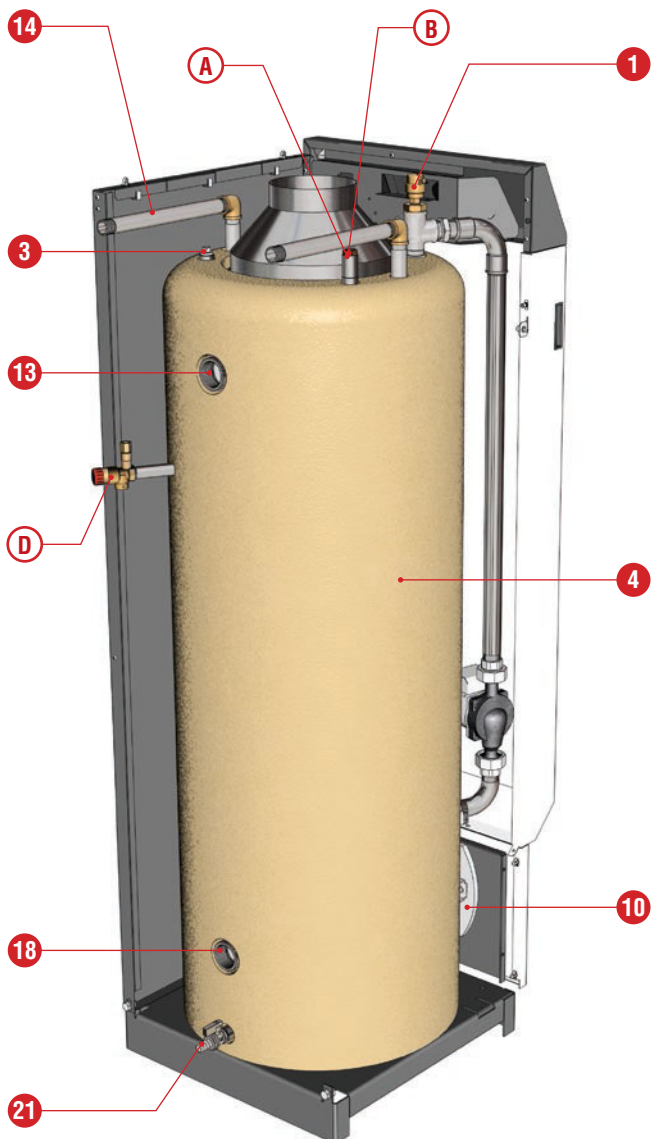

APPLIANCE DESCRIPTION

Description HeatMaster® 70 N / 100 N

1. Automatic air bleed valve
2. Cold water inlet
3. Dry well
4. Hard polyurethane foam insulation
5. Casing front panel
6. Primary expansion vessels
7. Control panel
8. Loading pump
9. Burner cover
10. Burner chamber plate insulation
11. Top cover
12. Flue reduction collar
13. Heating circuit outlet
14. Domestic hot water outlet
15. Stainless steel "Tank in Tank" hot water production tank
16. Flue pipes and turbulators
17. Primary circuit
18. Heating circuit return
19. Combustion chamber
20. Oil burner chamber plate
21. Draining valve

22. Gasket for the flue reduction collar
23. Casing reinforcement bracket

- A. Automatic reset high limit thermostat
- B. Manual reset high limit thermostat
- C. Low water pressure switch
- D. Primary circuit safety valve
- E. Control thermostat

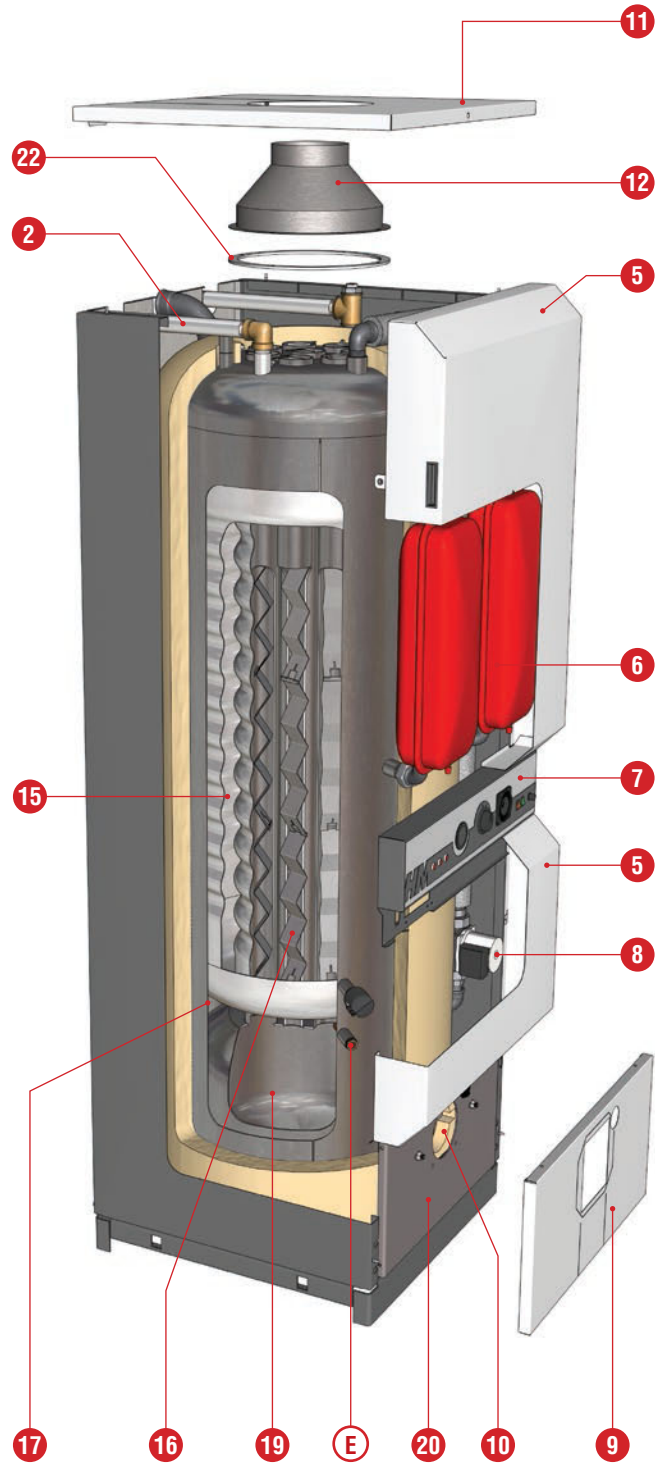
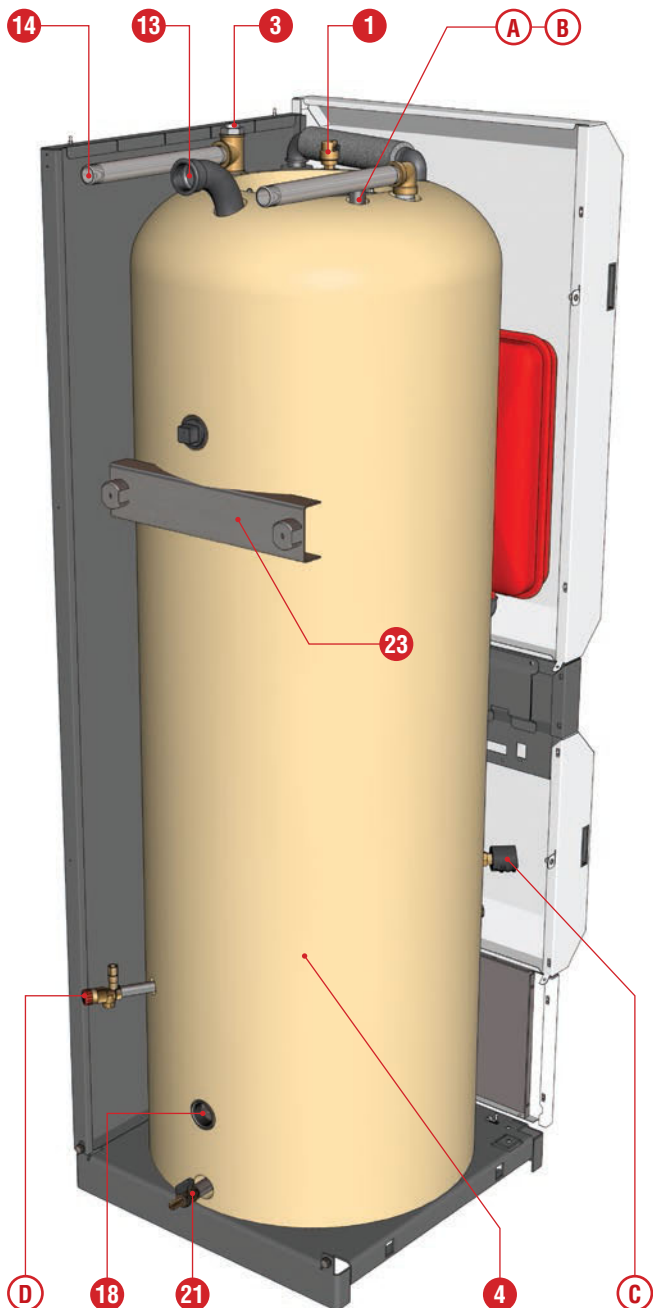

TECHNICAL CHARACTERISTICS

DIMENSIONS

HeatMaster® 30 N / 60 N

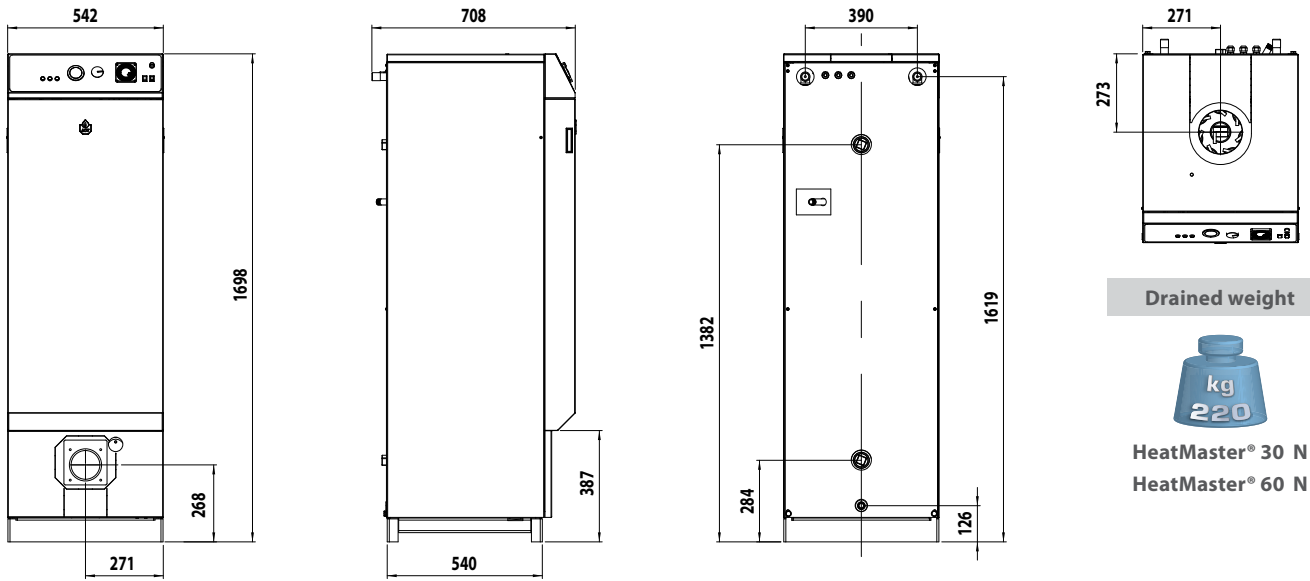

HeatMaster® 70 N / 100 N

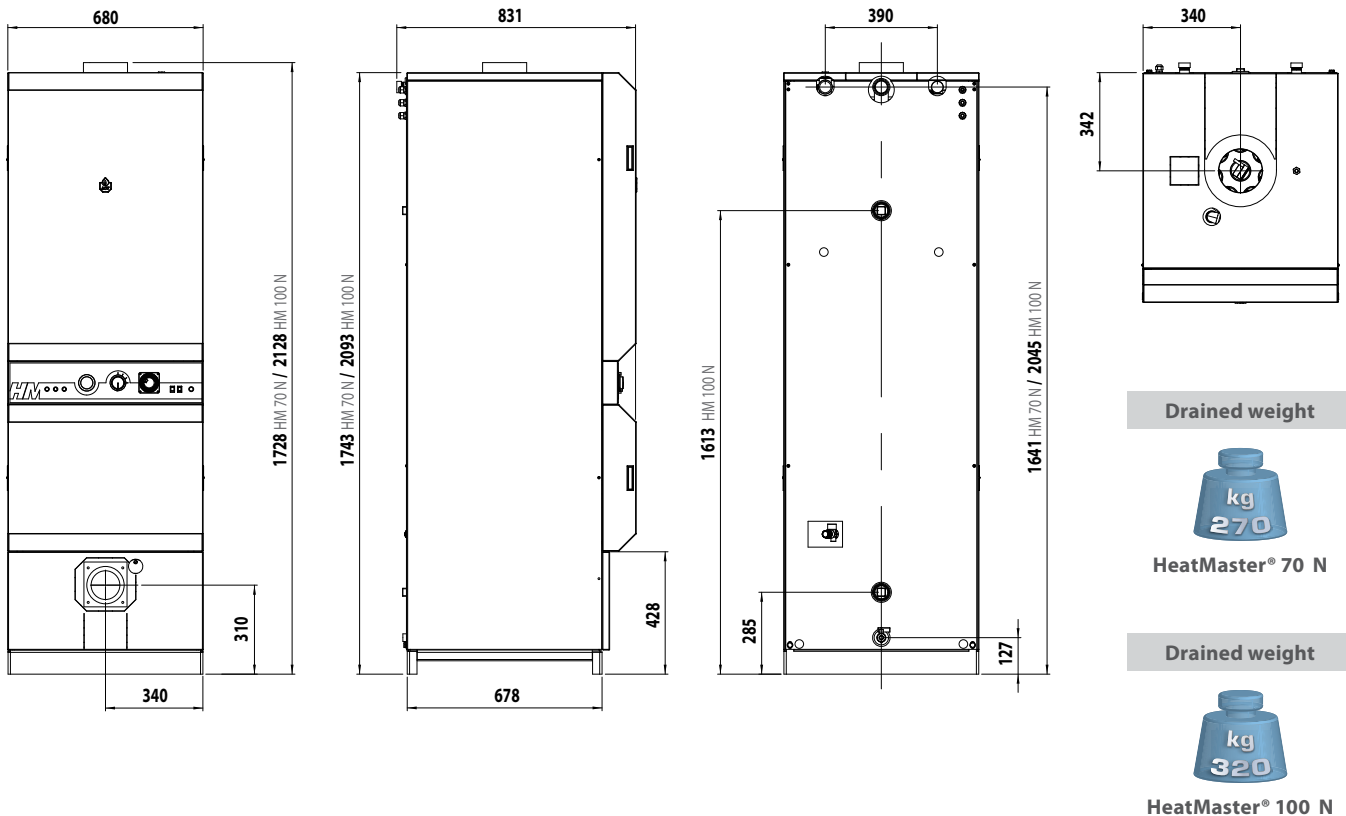

TECHNICAL CHARACTERISTICS

BOILER CLEARANCE

	Recommended	Minimum
A (mm)	650	500
B (mm)	800	700
C (mm)	500	300
D (mm)	300	250
E (mm)	150	100
F (mm)	800	700

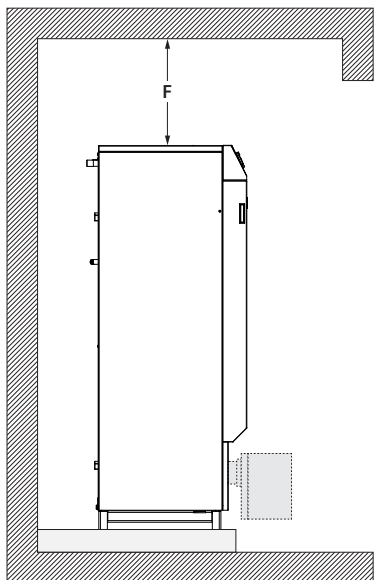
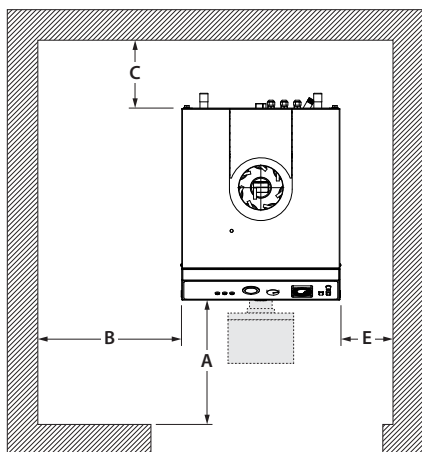
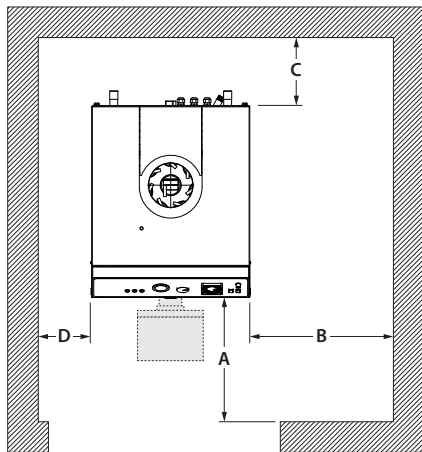

BURNER CHAMBER PLATE

The burner chamber plate has four threaded holes (M8) to attach the burner. It is protected from heat by a blanket insulation.

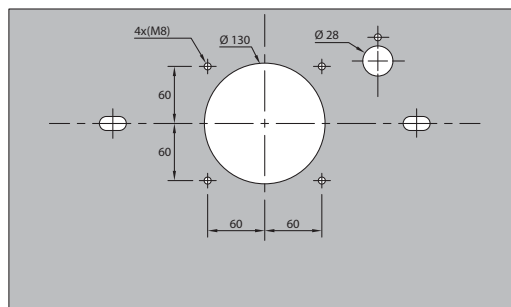

TECHNICAL CHARACTERISTICS

COMBUSTION CHARACTERISTICS

HEATMASTER® WITHOUT BURNER		HeatMaster® 30 N	HeatMaster® 60 N	HeatMaster® 70 N	HeatMaster® 100 N
Maximum input	kW	34.9	69.9	69.9	107.0
Maximum output	kW	31.4	63.0	63.0	96.3
Maintenance loss at 60% of rated value	%	0.69	0.57	0.60	0.65
HEATMASTER® PROVIDED WITH A BG 2000-S BURNER		HeatMaster® 30 N + BG 2000-S / 35	HeatMaster® 60 N + BG 2000-S / 60	HeatMaster® 70 N + BG 2000-S / 70	HeatMaster® 100 N + BG 2000-S / 100
Maximum input (PCI) - [G20 - G25]	kW	34.9	69.9	69.9	107.0
Maximum input (PCI) - [G31]	kW	NC	69.9	69.9	110.0
Maximum output - [G20 G25]	kW	31.4	63.0	63.0	96.3
Maximum output - [G31]	kW	NC	63.0	63.0	99.0
Rated efficiency	%	90.0	90.1	90.2	90.5
Efficiency at 30% load	%	95.0	96.6	96.7	96.4
Combustion efficiency	%	92.0	91.2	91.5	92.1
Gas: G20 - 20 mbar I2E(S) // I2H // I2Er // I2ELL // I2E // I2E(R)					
Flow rate	m³/h	3.70	7.40	7.40	11.32
Gas: G25 - 25 mbar I2L					
Flow rate	m³/h	—	8.60	8.60	13.17
Gas: G31 - 37/50 mbar I3P					
Flow rate	m³/h	1.43	2.86	2.86	4.50

HYDRAULIC CHARACTERISTICS

		HeatMaster® 30 N	HeatMaster® 60 N	HeatMaster® 70 N	HeatMaster® 100 N
Heating Connection [F]	Ø	1"1/2	1"1/2	1"1/2	1"1/2
DHW Connection [M]	Ø	3/4"	3/4"	1"	1"
DHW tank heat exchanger surface	m²	2.46	2.46	3.14	3.95
Primary circuit water pressure drop ($\Delta T = 20K$)	mbar	27	54	46	83
Total capacity	L	162	162	239	330
Primary circuit capacity	L	82	82	108	130

DOMESTIC HOT WATER PERFORMANCE *

OPERATING CONDITIONS AT 90°C		HeatMaster® 30 N	HeatMaster® 60 N	HeatMaster® 70 N	HeatMaster® 100 N
Peak flow at 40°C [$\Delta T = 30 K$]	L/10'	380	474	646	905
Peak flow at 45°C [$\Delta T = 35 K$]	L/10'	320	378	543	777
Peak flow at 40°C [$\Delta T = 30 K$]	L/60'	1130	1942	2133	3172
Peak flow at 45°C [$\Delta T = 35 K$]	L/60'	963	1656	1794	2680
Constant flow at 40°C [$\Delta T = 30 K$]	L/h	900	1835	1835	2776
Constant flow at 45°C [$\Delta T = 35 K$]	L/h	772	1573	1573	2379
Reheat time at 60°C	minutes	18	9	16	13

* for DHW temperatures > 45°C ($\Delta T > 35K$), please contact ACV



The temperature of the domestic hot water can be adjusted up to 90 °C in the boiler. However, the temperature of the domestic hot water at the drawing point must comply with local regulations. (E.g. in Belgium, the maximum DHW water temperature at a drawing point must be 75°C for boilers < 70 kW). For special applications, please contact ACV.

BURNER

All the HeatMaster® N boilers can be equipped with an oil or gas burner available on the market.

The HeatMaster® N can be factory fitted with a low NOx premix gas burner (BG 2000-S).



TECHNICAL CHARACTERISTICS

MAXIMUM OPERATING CONDITIONS

Maximum Service Pressure (DHW tank full of water)

- Primary circuit 3 bar
- DHW circuit 10 bar

Maximum Test Pressure (DHW tank full of water)

- Primary circuit 4.5 bar
- DHW circuit 13 bar

Maximum Operating Conditions

- Maximum temperature of primary fluid 90 °C
- Minimum temperature of primary fluid 60 °C

Water Quality

- Chlorides ≤ 150 mg/l (304)
- 6 ≤ pH ≤ 8

CHIMNEY CONNECTION CHARACTERISTICS

HEATMASTER® WITHOUT BURNER		HeatMaster® 30 N	HeatMaster® 60 N	HeatMaster® 70 N	HeatMaster® 100 N
Volume of the combustion chamber	m ³	0.051	0.051	0.075	0.075
Mass flow rate of combustion products	g/s	15.2	30.6	30.6	46.9
Max. pressure drop in flue pipe	Pa	1	60	60	140
Flue pipe diameter	mm	150	150	150	150
Net temperature	°C	180	195	170	170
B23		✓	✓	✓	✓
HEATMASTER® PROVIDED WITH AN ACV BG 2000-S BURNER		HeatMaster® 30 N + BG 2000-S / 35	HeatMaster® 60 N + BG 2000-S / 60	HeatMaster® 70 N + BG 2000-S / 70	HeatMaster® 100 N + BG 2000-S / 100
Mass flow rate of combustion products	g/sec.	16.0	32.1	32.1	51.4
Net temperature	°C	163	186	172	165
B23		✓	✓	✓	✓
B23P		✓	✓	✓	✓
C13		✓	✓	✓	✓
C33(x)		✓	✓	✓	✓
C53(x)		✓	✓	✓	✓
C63(x) - only in Germany and Luxemburg				✓	

BOILER ROOM

- make sure that all air vents are unobstructed at all times.
- do not store any flammable products in the boiler room.
- do not store any corrosive products, paint, solvents, salts, chloride products and other detergent products near the appliance.
- if you smell gas, do not switch on or off any lights, turn off the gas meter, ventilate the rooms and contact your installer.
- The base on which the boiler rests must be made of non-combustible materials.

CHIMNEY CONNECTION

- Chimney connection must comply with the applicable standards (NBN D51-003 in Belgium), and take into account the local requirements of the energy provider, the fire requirements and the regulation on "noise pollution".
- The flue pipe size must not be smaller than the size of the boiler outlet connection

B23 and B23P type chimney connection

The boiler is connected to the chimney by a metal pipe rising at an angle from the boiler to the chimney. A flue disconnection piece is required. It must be easily removable to give access to the flue pipes when performing boiler maintenance.

Due to the high efficiency of our boilers, the flue gases exit at a low temperature. Accordingly, there is a risk for the flue gases to condense, which could damage the chimney and the boiler. Therefore, it is strongly recommended to line the chimney.

Minimum supply of fresh air into the boiler room

		Fresh air supply	
		High	Low (B23 and B23P)
HeatMaster® 30N	cm ²	≥ 150	≥ 200
HeatMaster® 60N	cm ²	≥ 150	≥ 200
HeatMaster® 70 N	cm ²	≥ 150	≥ 200
HeatMaster® 100N	cm ²	≥ 210	≥ 320

Dimensions of a B23 type chimney

		Height		
		5 m	10 m	15 m
HeatMaster® 30N	Ø mm	150	150	150
HeatMaster® 60N	Ø mm	189	159	150
HeatMaster® 70 N	Ø mm	189	159	150
HeatMaster® 100N	Ø mm	234	178	150



Note:

Given that regulations vary from one country to another, the table above is given by way of indication only.

TYPE C CHIMNEY CONNECTION

- **C13** : concentric horizontal connection
- **C33(x)**: concentric vertical connection
- **C53(x)**: parallel chimney connection
- **C63(x)**: concentric vertical connection without terminal
(Only in Germany and Luxemburg)

The maximum pressure drop in flue pipe (air inlet + flue gas outlet) cannot exceed **100 Pa** - see table below indicating the pressure drop for each of the components).

A = fresh air supply
B = flue gas

	HeatMaster®			
	30N / 60N / 70N		100 N	
	A	B	A	B
	Ø 80	Ø 150	Ø 100	Ø 150
1m straight pipe	6	1	6	2
90° elbow	15	2	15	5
45° elbow	6	1	6	2
Condensate recovery container	-	2	-	4
Terminal	20	10	20	20

This table is based on ACV equipment and cannot be applied as a rule



In the case of a concentric connection, the total flue pipe length is limited to 6 meters.

A condensate outlet connected to the sewer must be fitted close to the boiler to prevent the condensation products from the chimney from running into the boiler.

To avoid condensation water running out of the terminal, all horizontal flue ducts must be installed with a slight downward slope toward the boiler.

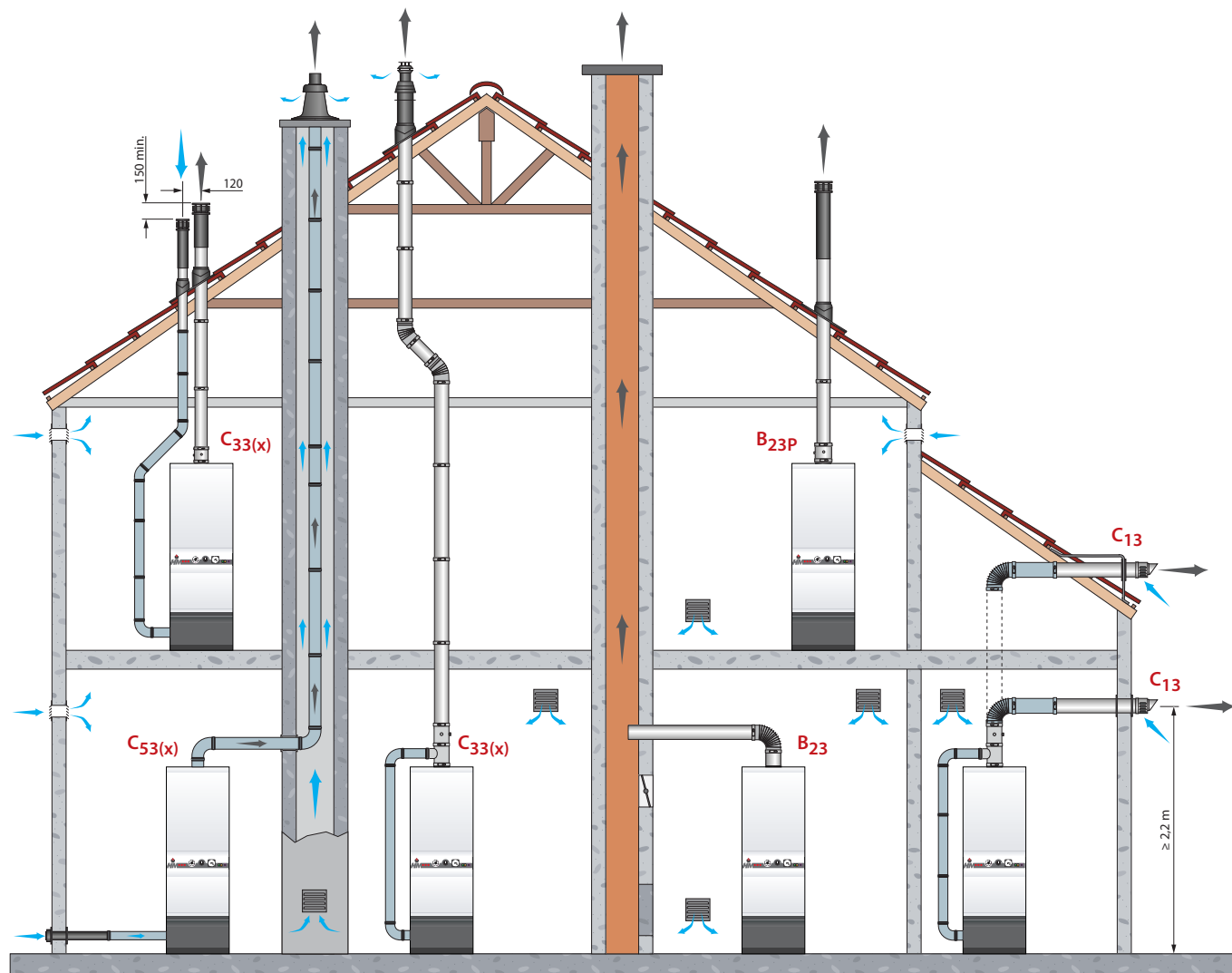

ELECTRICAL CHARACTERISTICS

WIRING DIAGRAM

1. 230 Volt electrical supply connection plug
2. Master switch
3. High limit thermostat indicator
4. Manual reset high limit thermostat
5. Low primary water pressure indicator
6. Low water pressure switch
7. Daily timer
8. Summer/winter switch
9. Burner safety cutout warning indicator
10. Room temperature (option)
11. Heating pump (option)
12. Charging pump **HeatMaster®**
13. Burner
14. Flow rate sensor (option)
15. Automatic reset high limit thermostat (95°C)
16. Control thermostat

MAIN ELECTRICAL CHARACTERISTICS

HeatMaster®	30 N / 60 N / 70 N / 100 N	
Rated voltage	V~	230
Rated frequency	Hz	50
Max. electrical consumption	W	82
Rated current	A	6

!

This wiring is factory-installed to use an oil burner

When using a BG 2000-S burner, it is imperative to move electrical bridge (12-15) to (15-16).

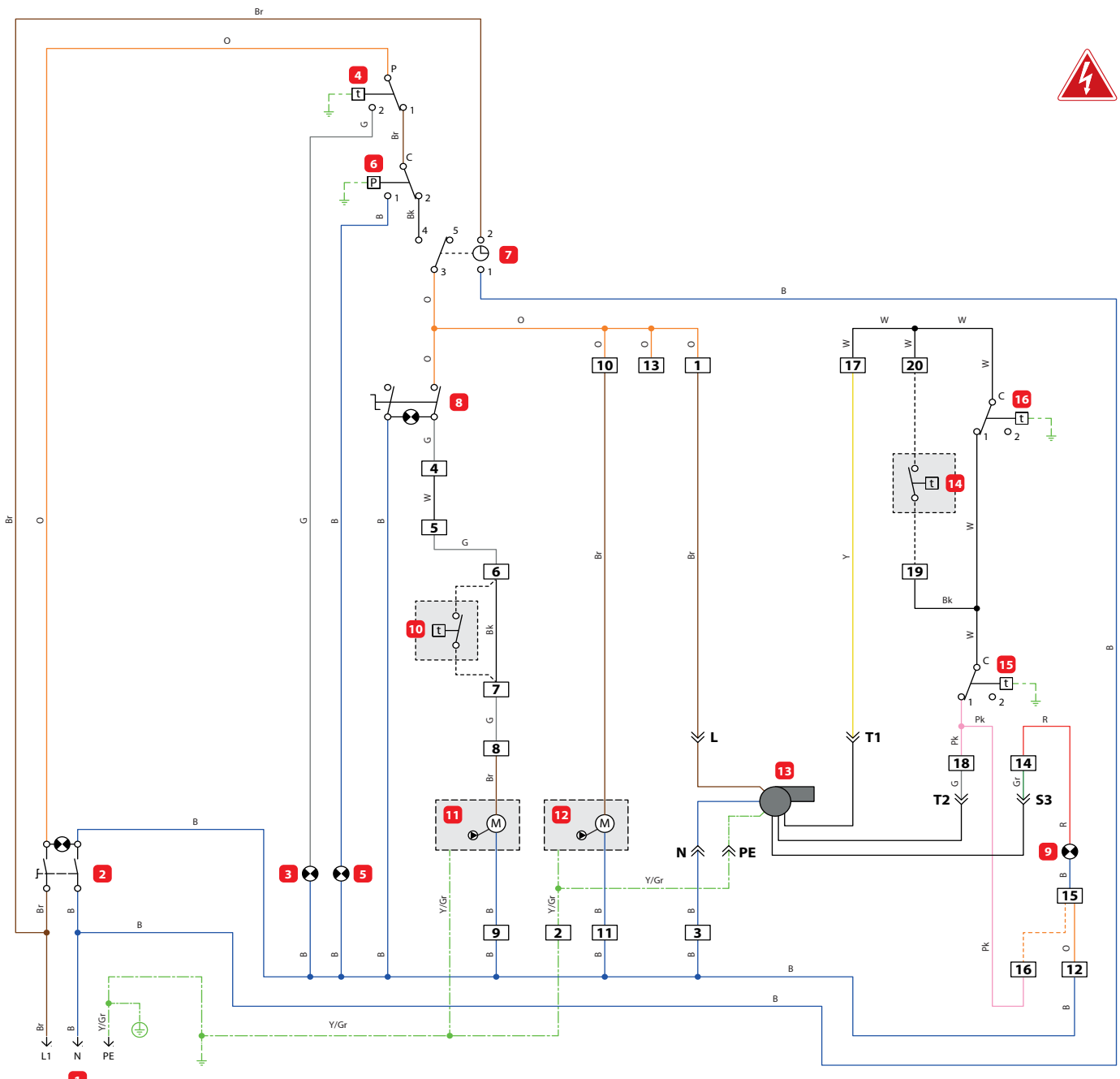

- | | | | |
|-----------|-----------|----------|--------------------|
| B. Blue | G. Grey | Pk. Pink | Y. Yellow |
| Bk. Black | Gr. Green | R. Red | Y/Gr. Yellow/Green |
| Br. Brown | O. Orange | W. White | |



INSTALLATION

PACKAGE CONTENTS

The appliances are delivered tested and packaged on a wooden support, protected by anti-shock corner pieces and wrapped in a plastic film.

At product reception and after removal of packaging, check the package contents and that the appliance is free of damages.

Contents

- A **HeatMaster® N** boiler
- Installation, operation and maintenance instructions
- A hydraulic kit, comprised of:
 - A primary safety valve \varnothing 1/2" F
 - A reducer \varnothing 1/4" F - \varnothing 1/8" M
 - A check-valve \varnothing 1/4" F - \varnothing 1/4" M
 - A draining valve \varnothing 1/2" M

BOILER PREPARATION

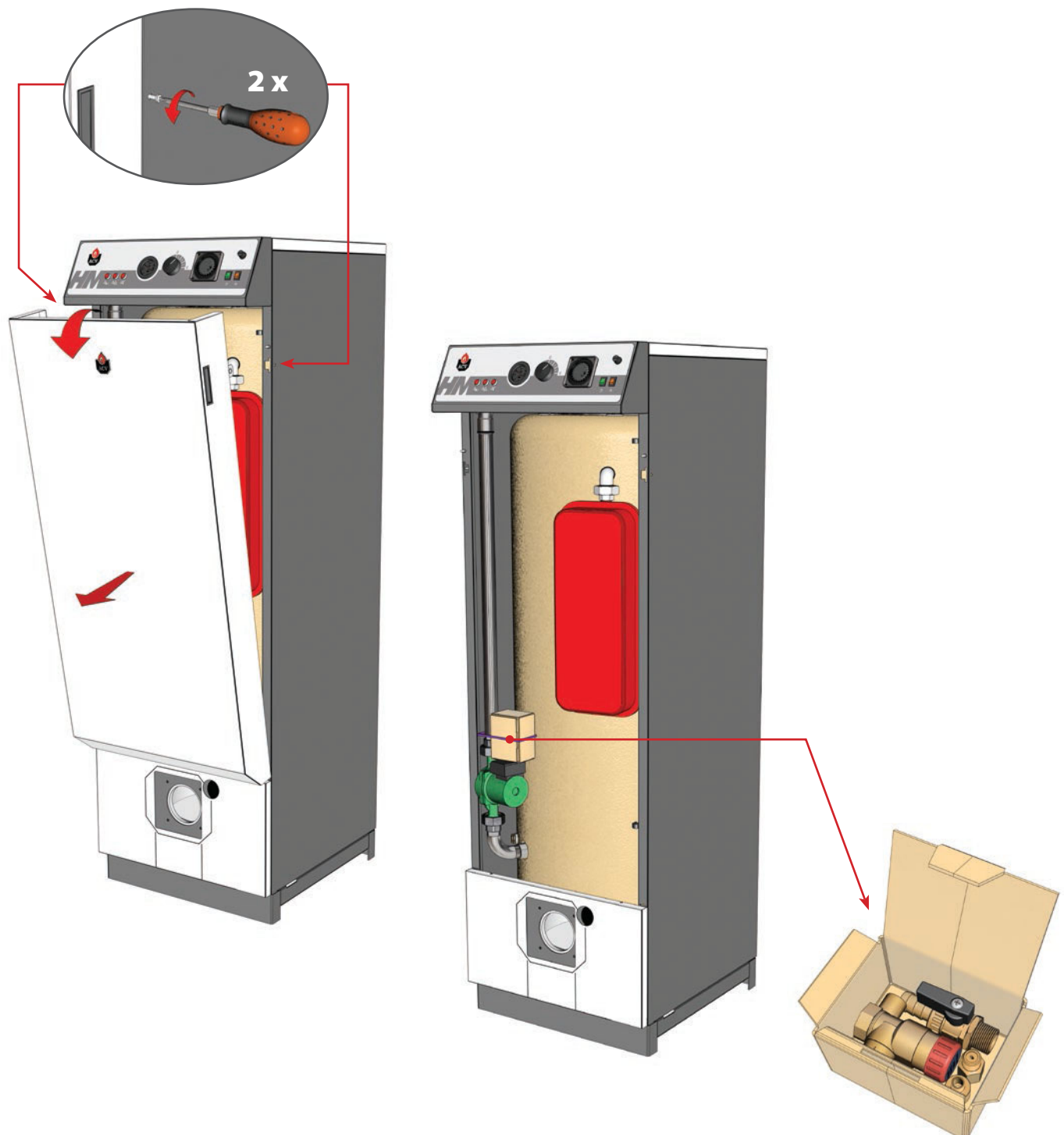

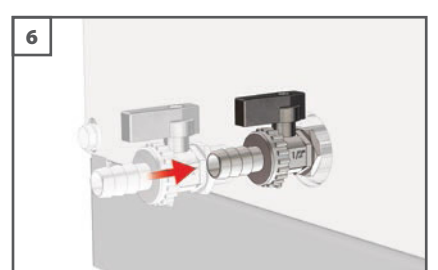
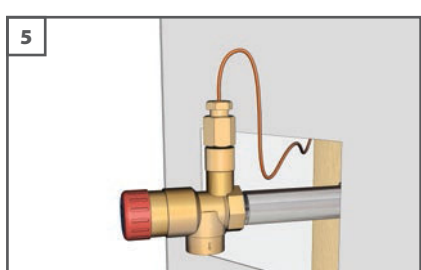
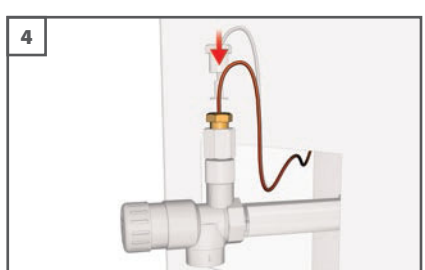
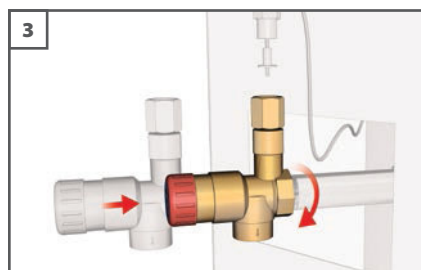
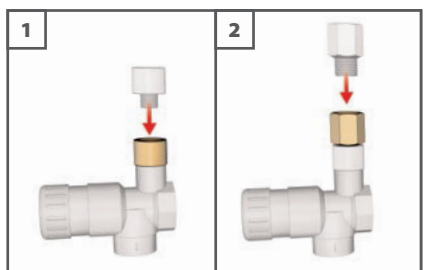

INSTALLATION

DHW CONNECTION



The DHW tank must be pressurized before putting the primary circuit (heating) under pressure.

The HeatMaster® boiler can be connected directly to the DHW circuit.

Flush the system before connecting the domestic hot water circuit.

The installation must be fitted with an approved safety group, comprised of a 7 bar safety valve, a check valve and a shut-off valve.

During the heating process, the domestic hot water expands and the pressure increases. As soon as the pressure exceeds the safety valve setting, the valve opens and discharges a small quantity of water. Using a hot water expansion vessel (2 liters at least) will prevent this phenomenon and reduce the water hammer effect.



The hot water output may reach temperatures in excess of 60°C, which can cause burns. ACV therefore recommends that you install a thermostatic mixing valve immediately after the appliance outlet.



If stop valves are used in the domestic hot water system, they can cause pressure changes when closed. Use devices designed to reduce water hammer effect to avoid this phenomenon.

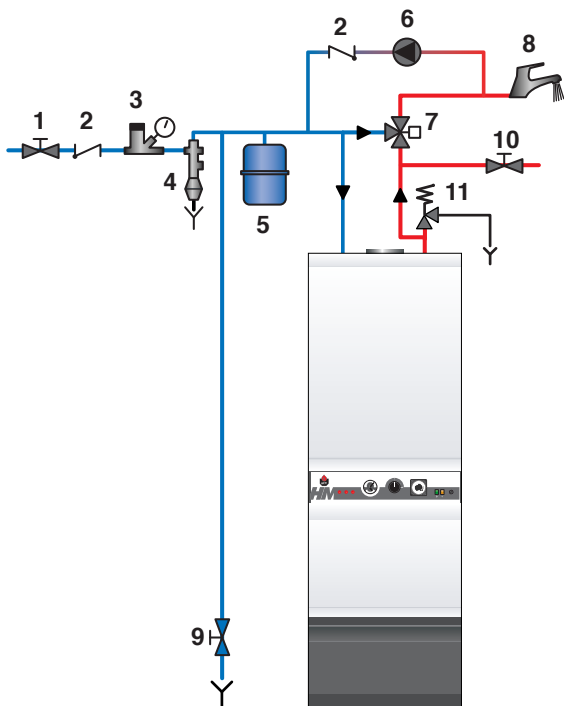

1. Cold water supply valve
2. Check valve
3. Pressure reducing valve
4. Domestic hot water safety valve set at 7 bar
5. DHW circuit expansion vessel
6. DHW secondary pump (if fitted)
7. Thermostatic mixing valve
8. Draw-off tap
9. Draining valve
10. Stop valve for cleaning
11. Temperature relief valve (UK only)

EXAMPLE OF PARALLEL CONNECTION

Recommended for applications with a high constant flow.

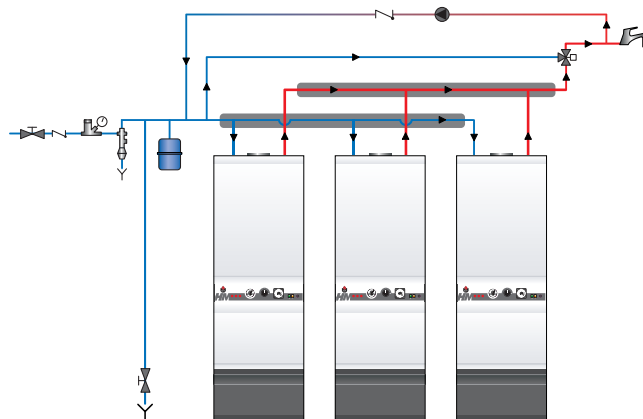

EXAMPLE OF SERIES CONNECTION

Preferable for high-temperature applications with up to 3 units

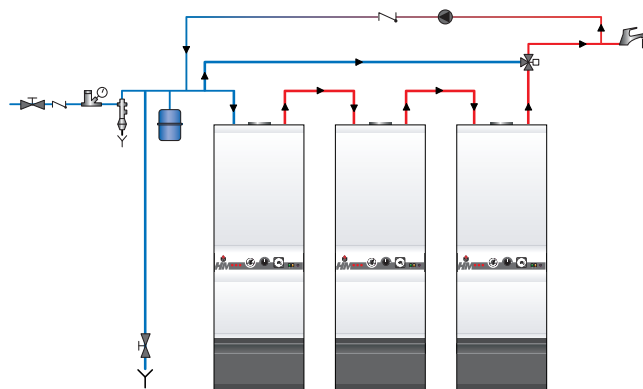

EXAMPLE OF HEATING + STORAGE CONNECTION

Recommended for applications requiring a high peak flow.

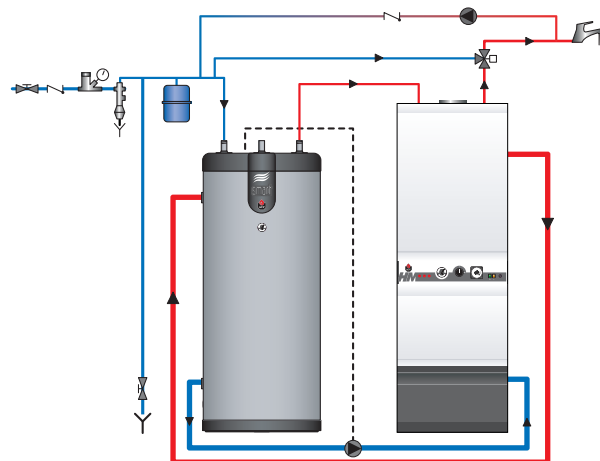

HEATING CONNECTION



The DHW tank must be pressurized before putting the primary circuit (heating) under pressure.

Two couplings are installed at the back of the **HeatMaster**®, that can be used to connect a central heating circuit.

Connecting a heating system may reduce the domestic hot water performance.

EXPANSION VESSEL

The **HeatMaster**® 30 N and 60 N are fitted with an 8 liter expansion vessel.

The **HeatMaster**® 70 N and 100 N are fitted with two 10 liter expansion vessels. These expansion vessels are sized for hot water operation only. If the heating system is connected to the primary circuit, calculate the expansion capacity necessary for the total volume of the heating system (refer to the technical instructions from a relevant manufacturer of expansion vessels).



WARNING

The primary safety valve is supplied with a plastic tube connected to discharge outlet - this is for test purposes only and should be removed.

The safety valve should be connected to the sewer using a metallic pipe, e.g. copper.

1. 4-way mixing valve
2. Heating pump
3. Check valve
4. Heating circuit isolating valves
5. Safety valve set at 3 bar with pressure gauge
6. Expansion vessel
7. Drain valve
8. Primary circuit filling valve
9. Controller
10. Contact sensor
11. Room thermostat
12. Outdoor temperature sensor

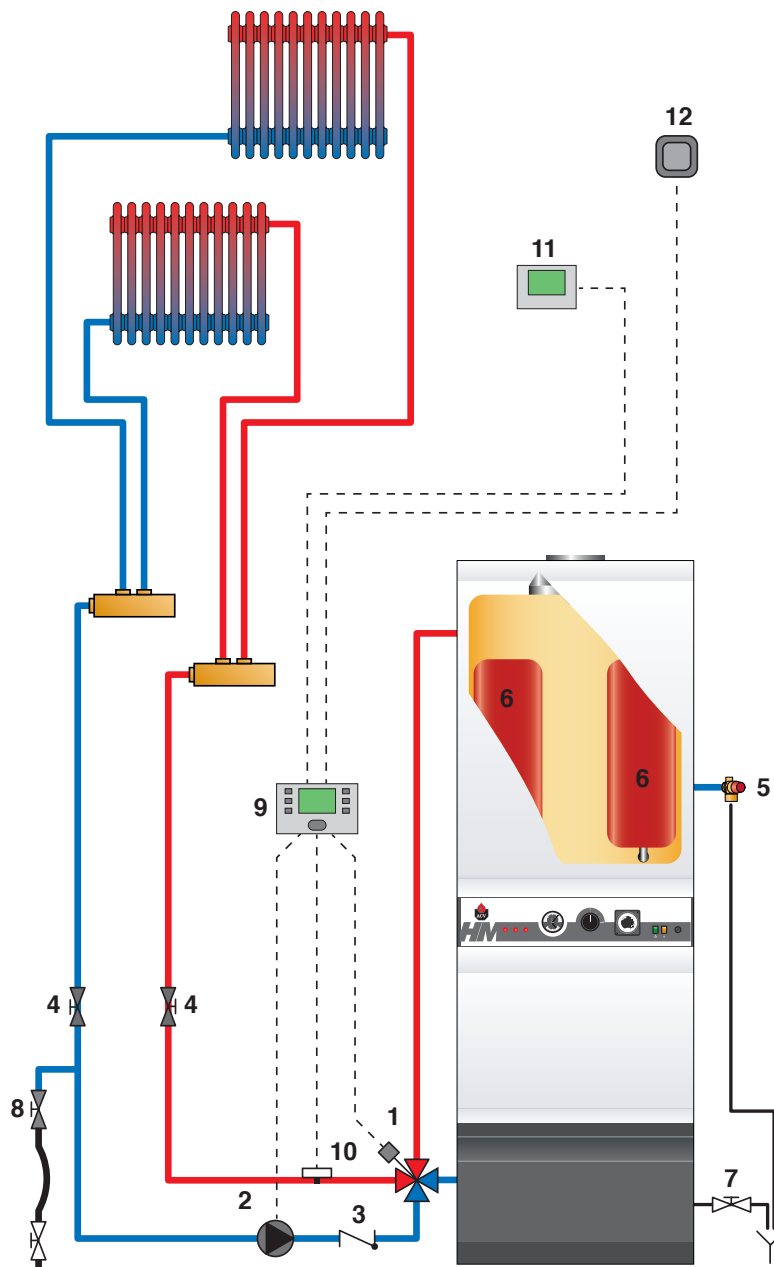

STARTING UP

FILLING THE DOMESTIC HOT WATER AND HEATING CIRCUITS



IMPORTANT

Before pressurizing the central heating circuit, you should first put the domestic hot water tank under pressure.

FILLING THE DOMESTIC HOT WATER CIRCUIT

1. Open the filling valve (1) and the drawoff tap (2).
2. When water flows out of the tap, the hot water tank is full and the drawoff tap (2) should be closed.

PRELIMINARY FILLING OF THE HEATING CIRCUIT

1. Open the stop valves (A).
2. Make sure that the draining valve (D) is fully closed.
3. Open the filling valves (B and C) to start filling the primary circuit with mains water until you reach an approximate pressure of 1,5 bar in the system.
4. Bleed the boiler and the whole system using the automatic air bleed valve located on top of the appliance.

STARTING UP THE BOILER

STARTING THE BURNER

1. Set the boiler master switch on "ON" and the summer/winter switch on the "❄️" symbol.
2. Rotate the boiler control thermostat clockwise to generate a heat demand.
3. Possibly increase the set temperature of the room thermostat, if installed.

ADJUSTING THE COMBUSTION

1. Refer to the starting up instructions detailed in the technical manual of the burner.
2. Adjust CO₂ as described in the Starting up paragraph of the burner.
3. Check temperatures and CO level.

BLEEDING THE HEATING CIRCUIT

1. Bleed the heating circuit again to restore a 1.5 bar pressure.
2. Repeat the sequence until complete evacuation of the air contained in the circuit.

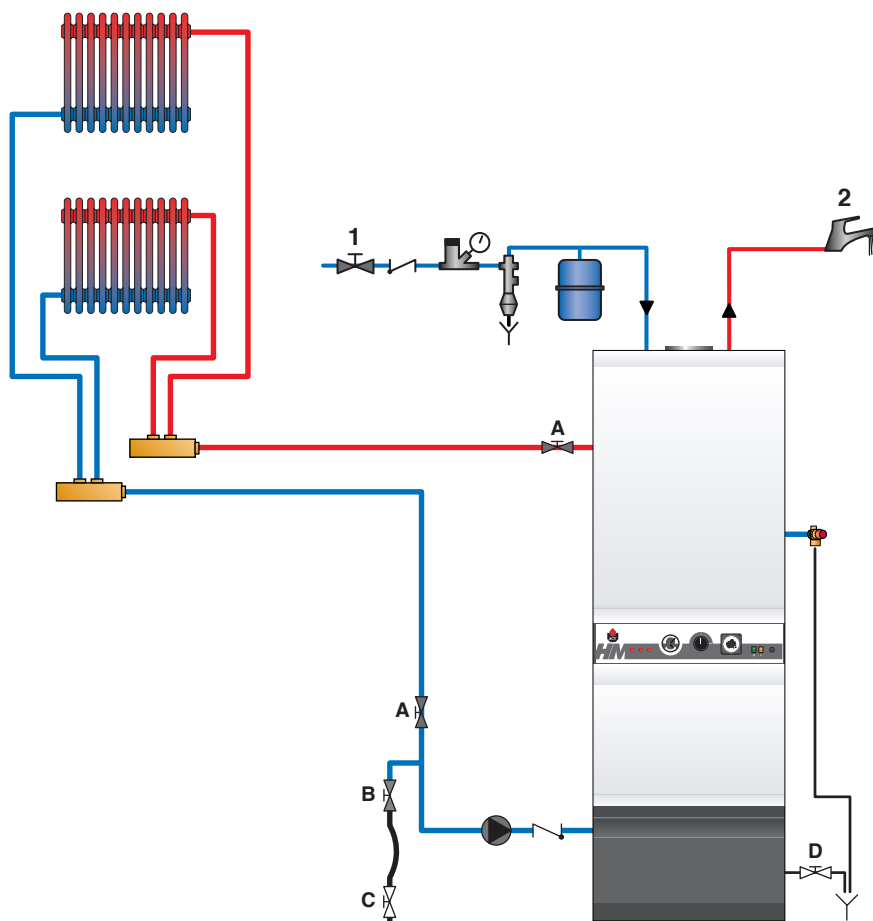

ANNUAL MAINTENANCE

ACV recommends the boilers should be serviced at least once a year. Maintenance and the burner control must be performed by a qualified engineer.

More frequent servicing may be required depending on boiler use. If this is the case, consult your installer for advice.

BOILER MAINTENANCE

1. Put the master switch on the control panel on "OFF" and isolate power supply to the unit.
2. Turn off the gas or oil supply to the boiler.
3. Remove the flue pipe to gain access to the top of the boiler
4. Remove the casing top panel and lift off the flue reduction collar by releasing the fastening bolts.
5. Remove the turbulators from the flue pipes for cleaning.
6. Unscrew the burner chamber plate and remove the burner
7. Brush the flue pipes.
8. Clean the burner chamber and the burner.
9. Reassemble turbulators, flue reduction collar and flue pipe, checking that the gasket of the flue reduction collar is in good condition. Replace gasket if necessary.

MAINTENANCE OF THE SAFETY DEVICES

- Check that all thermostats and safety devices are working properly.
- Test the safety valves on the central heating and hot water circuits.

SERVICING THE BURNER

For all burners, please refer to the relevant servicing and troubleshooting instructions in the technical manual of your burner.

DRAINING THE BOILER



Water flowing out of the drain valve may be extremely hot and could cause severe scalding. Keep people away from discharge of hot water.

DRAINING THE HEATING CIRCUIT

1. Put the master switch of the control panel on OFF, isolate the external electrical supply and turn off the gas or oil supply to the boiler.
2. Close the isolating valves (4) or put manually the 4-way mixing valve (1) on "0".
3. Connect a hose to the draining valve (7).
4. Open the draining valve to empty the primary circuit.

DRAINING THE DHW CIRCUIT

1. Put the master switch of the control panel on OFF, isolate the external electrical supply and turn off the gas or oil supply to the boiler.
2. Release the pressure in the heating circuit until the pressure gauge indicates 0 bar.
3. Close valves (1) and (8).
4. Open valves (9) and (10) (first 9 then 10).
5. Allow the drained water to flow into the sewer.



For the circuit to be drained, the draining valve (9) must be located at ground level.

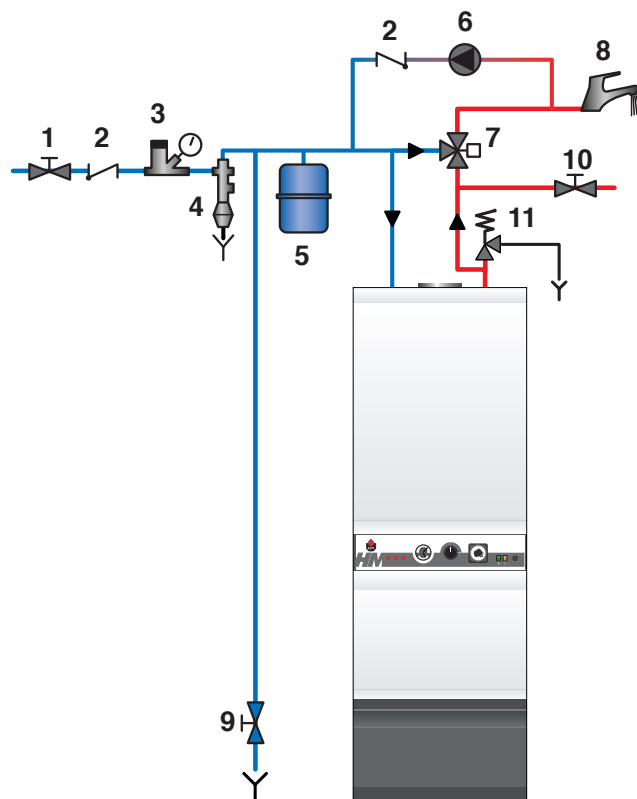
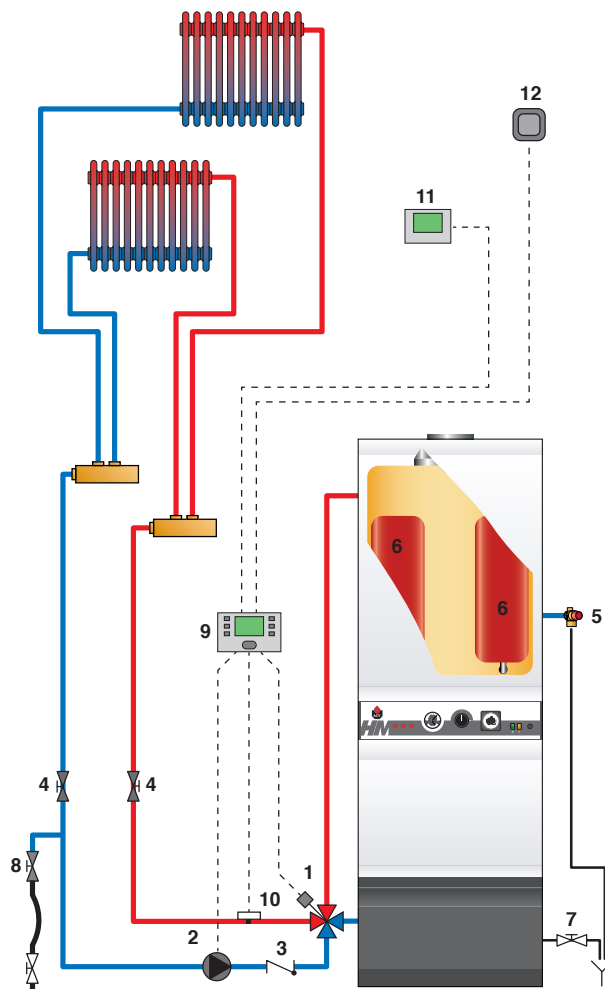



excellence in hot water



DECLARATION OF CONFORMITY - CE

1/2

Name and address of manufacturer: **ACV International SA / NV**
Kerkplein, 39
B-1601 Ruisbroek

Description of product type: **Low temperature boiler**

Models: **HeatMaster HM 30 N**
HeatMaster HM 60 N
HeatMaster HM 100 N

CE #: **0461BN0650**

We declare hereby that the appliance specified above is conform to the type model described in the CE certificate of conformity to the following directives:

Directives	Description	Date
92/42/EEC	Efficiency Requirements Directive	20.03.2008
2006/95/EC	Voltage Limits Directive	12.12.2006
2004/108/EC	Electromagnetic Compatibility Directive	15.12.2004

We declare under our sole responsibility that the product **HeatMaster** complies with the following standards and directives:

EN 303-1

EN 60335-2-102

Ruisbroek, 24/09/2013

Date

Director R & D
Marco Croon





excellence in hot water



DECLARATION OF CONFORMITY - CE

2/2

Name and address of manufacturer: **ACV International SA / NV**
Kerkplein, 39
B-1601 Ruisbroek

Description of product type: **Low temperature boiler - Gas**

Models: **HeatMaster HM 30 N BG2000-S/35**
HeatMaster HM 60 N BG2000-S/60
HeatMaster HM 100 N BG2000-S/107

CE #: **0461BN0650**

We declare hereby that the appliance specified above is conform to the type model described in the CE certificate of conformity to the following directives:

Directives	Description	Date
92/42/EEC	Efficiency Requirements Directive	20.03.2008
2009-142-CE	Gas Appliances Directive	30.10.2009
2006/95/EC	Voltage Limits Directive	12.12.2006
2004/108/EC	Electromagnetic Compatibility Directive	15.12.2004

We declare under our sole responsibility that the product **HeatMaster** complies with the following standards and directives:

EN 483

EN 483/A2

EN 60335-2-102

EN 55014-1

EN 55014-2

EN 61000-3-2

EN 61000-3-3

Ruisbroek, 24/09/2013

Date

Director R & D
Marco Croon





excellence in hot water



DECLARATION OF CONFORMITY - CE

1/2

Name and address of manufacturer: **ACV International SA / NV**
Kerkplein, 39
B-1601 Ruisbroek

Description of product type: **Low temperature boiler**

Models: **HeatMaster HM 70 N**

CE #: **0461BN0684**

We declare hereby that the appliance specified above is conform to the type model described in the **CE** certificate of conformity to the following directives:

Directives	Description	Date
92/42/EEC	Efficiency Requirements Directive	20.03.2008
2006/95/EC	Low Voltage Directive	12.12.2006
2004/108/EC	Electromagnetic Compatibility Directive	15.12.2004

We declare under our sole responsibility that the product **HeatMaster** complies with the following standards and directives:

EN 303-1

EN 60335-2-102

Ruisbroek, 24/09/2013

Date

Director R & D
Marco Croon



664Y5400-B



excellence in hot water



DECLARATION OF CONFORMITY - CE

2/2

Name and address of manufacturer: **ACV International SA / NV**
Kerkplein, 39
B-1601 Ruisbroek

Description of product type: **Low temperature boiler - Gas**

Models: **HeatMaster HM 70 N BG2000-S/70**

CE #: **0461BN0684**

We declare hereby that the appliance specified above is conform to the type model described in the **CE** certificate of conformity to the following directives:

Directives	Description	Date
92/42/EEC	Efficiency Requirements Directive	20.03.2008
2009-142-CE	Gas Appliances Directive	30.10.2009
2006/95/EC	Low Voltage Directive	12.12.2006
2004/108/EC	Electromagnetic Compatibility Directive	15.12.2004

We declare under our sole responsibility that the product **HeatMaster** complies with the following standards and directives:

EN 483

EN 483/A2

EN 60335-2-102

EN 55014-1

EN 55014-2

EN 61000-3-2

EN 61000-3-3

Ruisbroek, 24/09/2013

Date

Director R & D
Marco Croon



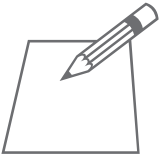

A series of horizontal dotted lines extending across the page, providing a guide for handwriting practice.



A series of horizontal dotted lines for writing, starting from the top right of the notepad illustration and extending across the width of the page.

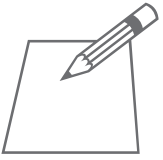

A series of horizontal dotted lines extending across the page, providing a guide for handwriting practice.