

Installation and Servicing Instructions

Alpha CD 13R, 18R and 24R

**Wall Mounted, Fan Assisted, Room Sealed, Gas Fired,
High Efficiency Condensing Regular Boiler Range**

For Technical help or for Service call ...
ALPHA HELPLINE Tel: 0844 871 8764
website: www.alpha-innovation.co.uk

Alpha
HEATING INNOVATION

Nepicar House, London Road,
Wrotham Heath, Sevenoaks,
Kent TN15 7RS



Alpha CD 13R (NG)	G.C. No. 41 532 05
Alpha CD 18R (NG)	G.C. No. 41 532 03
Alpha CD 24R (NG)	G.C. No. 41 532 04
Alpha CD 13R (LPG)	G.C. No. 41 532 11
Alpha CD 18R (LPG)	G.C. No. 41 532 09
Alpha CD 24R (LPG)	G.C. No. 41 532 10

British Gas
Service Listed



Set for use with Natural Gas

Leave these instructions with the User

These instructions have been carefully prepared but we reserve the right to alter the specification at any time in the interest of product improvement.
© Alpha Therm Limited 2015.

Part No. 1.038436 ST.001941/000
0615/D352

BENCHMARK SCHEME

To comply with Building Regulations Part L1 (Part 6 in Scotland) the boiler should be installed in accordance with the manufacturer's instructions. Self-certification that the boiler has been installed to comply with Building Regulations can be demonstrated by completing and signing the Benchmark Checklist at the back of these instructions

Code of Practice

For the installation, commissioning and servicing of domestic heating and hot water products.

Benchmark places responsibilities on both manufacturers and installers*. The purpose is to ensure that customers** are provided with the correct equipment for their needs, that it is installed, commissioned and serviced in accordance with the manufacturer's instructions by competent persons and that it meets the requirements of the appropriate Building Regulations. Installers are required to carry out work in accordance with the following:

Standards of Work

- Be competent and qualified to undertake the work required.
- Install, commission, service and use products in accordance with the manufacturer's instructions provided.
- Ensure that where there is responsibility for design work, the installation is correctly sized and fit for purpose.
- Meet the requirements of the appropriate Building Regulations. Where this involves notifiable work be a member of a Competent Persons Scheme or confirm that the customer has notified Local Authority Control (LABC), prior to work commencing.
- Complete all relevant sections of the Benchmark Checklist/Service Record when carrying out commissioning or servicing of a product or system.
- Ensure that the product or system is left in a safe condition and, where possible, in good working order.
- Highlight to the customer any remedial or improvement work identified during the course of commissioning or servicing work.
- Refer to the manufacturer's helpline where assistance is needed.
- Report product faults and concerns to the manufacturer in a timely manner.

Customer Service

- Show the customer any identity card that is relevant to the work being carried out prior to commencement or on request.
- Give a full and clear explanation/demonstration of the product or system and its operation to the customer.
- Hand over the manufacturer's instructions, including the Benchmark Checklist, to the customer on completion of an installation.
- Obtain the customer's signature on the Benchmark Checklist to confirm satisfactory demonstration and receipt of manufacturer's instructions.
- Advise the customer that regular product servicing is needed, in line with manufacturers' recommendations, to ensure that safety and efficiency is maintained.
- Respond promptly to calls from a customer following completion of their work, providing advice and assistance by phone and, if necessary, visiting the customer.
- Rectify any installation problems at no cost to the customer during the installer's guarantee period.

* The use of the word "installer" is not limited to installation itself and covers those carrying out installation, commissioning and/or servicing of heating and hot water products, or the use of supporting products (such as water treatment or test equipment).

** Customer includes householders, landlords and tenants.

Benchmark Commissioning and Servicing Section

It is a requirement that the boiler is installed and commissioned to the manufacturers instructions and the data fields on the commissioning checklist completed in full.

To instigate the boiler guarantee the boiler needs to be registered with the manufacturer within one month of the installation.

To maintain the boiler guarantee it is essential that the boiler is serviced annually by a Gas Safe registered engineer who has been trained on the boiler installed. The service details should be recorded on the Benchmark Service Interval Record and left with the householder.

www.centralheating.co.uk



Useful contact details: Gas Safe Register - 0800 408 5577 - www.gassaferegister.co.uk

Alpha Heating Innovation: General Sales Enquiries - 0844 871 8760
Technical Helpline - 0844 871 8764

CONTENTS

1	Introduction.....	3	8	Component replacement.....	29
2	Technical data	4	9	Wiring diagrams	33
3	General boiler information	8	10	Fault finding.....	35
4	Installation	15	11	Short parts list.....	38
5	Commissioning.....	23	12	Energy classification.....	39
6	Boiler operation	25		Benchmark Checklist.....	46
7	Routine servicing.....	26		Service record	47

1 INTRODUCTION

The Alpha CD Regular range of high efficiency condensing boilers are wall mounted, fan assisted room-sealed boilers. The burner is lit electronically and the heat output is controlled by a modulating fan and gas valve.

The boilers provide heating only with a fully pumped open vented systems and with the addition of a sealed system kit for sealed central heating systems.

IMPORTANT

Failure to install and commission this appliance in compliance with the manufacturer's instructions may invalidate the warranty. It is the law that all gas appliances are installed by a competent person, i.e. Gas Safe registered personnel, in accordance with the following recommendations:-

Current Gas Safety (Installation and Use) Regulations

All current Building Regulations issued by the Department of the Environment, i.e. Approved Document L1.

Building Standards (Scotland) (Consolidation) Regulations issued by the Scottish Development Department

UK Water Regulations/Byelaws (Scotland)

Health & Safety Document No. 635 (The Electricity At Work Regulations 1989)

The installation should also be in accordance with the following British Standard Codes of Practice:-

BS 5440:1	Flues
BS 5546:	Installation of hot water supplies for domestic purposes
BS 6700:	Design, installation, testing and maintenance of services supplying water
BS 6798:	Installation of gas fired hot water boilers
BS 6891:	Gas installation
BS 7593:	Code of Practice for treatment of water in heating systems
BS 7671:	Requirements for electrical installations, IEE Wiring Regulations
BS EN 12828	Heating systems in Buildings. Design for water based heating systems
BS EN 12831	Heating systems in Buildings. Method of calculation for design heat load
BS EN 14336	Heating systems in Buildings. Installation and commissioning of water based heating systems

Reference should be made to DEFRA document 'Guide to condensing boiler installation assessment procedures for dwellings'.

If installation is in a timber framed building, refer to the Institute of Gas Engineers document IGE/UP/7.

This appliance meets the requirements of IPX4D, i.e. degree of protection against moisture.

This appliance contains no asbestos and no substances have been used in the construction process that contravene the COSHH Regulations (Control of Substances Hazardous to Health).

Failure to install this appliance correctly could lead to prosecution. It is in your own interest and that of safety to ensure that the law is complied with.

Manufacturer's instructions must **NOT** be taken in anyway as over-riding statutory obligations.

- Notes:**
1. Ensure that the Benchmark Checklist has been completed after the boiler has been installed and commissioned.
 2. It is the law that all boiler installations are registered by the installer through the Gas Safe Gas Work Notification Scheme.
 3. The boiler must only be used with Alpha CD condensing flue components.

NOTE: All models may be supplied ready for use with Propane (LPG) - Refer to Section 2.2 for data specific to Propane versions.

The boilers are designed for use with a fully pumped, sealed and pressurised heating system using only Propane gas.

In addition to the regulations and requirements stated in these installation and servicing instructions, the boiler must be installed in accordance with BS 5482:1 - The Installation of Propane Burning Appliances in Permanent Dwellings.

Installation pipes, cylinders and pressure regulators should be fitted in accordance with BS5482:1. Bulk tank installations must comply with the requirements of the Home Office code of practice for the storage of liquefied petroleum gas at fixed installations.

Propane boilers **must not** be installed in a room or internal space below ground level, e.g. in a basement or cellar, except where at least one side is open to ground level.

Propane supply pipes must be capable of delivering the required quantity of gas in addition to the demand from any other appliances in the house. The complete installation must be tested for gas soundness against leaks.

Propane boilers have been tested and factory set for use with Propane, it should only be necessary to ensure the correct gas supply pressure of 37 mbar is available.

2 TECHNICAL DATA

2.1 TECHNICAL PERFORMANCE DATA - NATURAL GAS (Cat I2H 2H - G20 20 mbar)

		CD 13R	CD 18R	CD24R
Heat input gross - CH	kW	13.8	20.4	26.6
Heat input net - CH	kW	12.4	18.4	24.0
Heat output condensing (50/30°C) - CH	kW	13.1	19.6	25.6
Heat output non condensing (80/60°C) CH	kW	12.1	18.0	23.5
Heat output min. - CH	kW	5.4	5.4	6.5
Gas rate at max. output	m ³ /h	1.31	1.94	2.54
Gas supply pressure	mbar	20	20	20
Max. CH temperature	°C	82	82	82
Gas burner injector diameter	mm	5.1	5.1	5.25
Differential burner pressure - min.	mbar	0.4	0.4	0.6
Differential burner pressure - CH	mbar	1.7	3.54	1.45
NOx	Class	5	5	5
Factory set CO ₂ (± 0.25%)				
CO ₂ at maximum CH output	%	9.2	9.2	9.2
CO ₂ at minimum CH output	%	9.0	9.0	9.0
CO weight (nominal)	mg/kWh	16	25	27
CO (max)	ppm	200	200	200
Maximum CO/CO ₂	Ratio	0.003	0.003	0.003
SAP/SEDBUK seasonality efficiency 2005	%	90.1	90.1	90.3
SAP/SEDBUK seasonality efficiency 2009	%	88.5	88.4	88.6
Max. primary system pressure	bar	2.5	2.5	2.5
Min. primary system pressure	bar	0.5	0.5	0.5
Recommended system pressure - Cold	bar	1.0	1.0	1.0
Electrical power consumption - Max.	Watts	55	55	55
Electrical power consumption - Standby	Watts	6	6	6

2.2 TECHNICAL PERFORMANCE DATA - PROPANE GAS (Cat I3P 3P - G31 - 37 mbar)

		CD 13R	CD 18R	CD 24R
Heat input gross - CH	kW	13.8	20.4	26.6
Heat input net - CH	kW	12.4	18.4	24.0
Heat output condensing (50/30°C) - CH	kW	13.1	19.6	25.6
Heat output non condensing (80/60°C) CH	kW	12.1	18.0	23.5
Heat output min. - CH	kW	5.4	5.4	6.5
Gas rate at max. output	l/h	0.48	0.72	0.44
Gas supply pressure	mbar	37	37	37
Max. CH temperature	°C	82	82	82
Gas burner injector diameter	mm	4.0	4.0	4.0
Differential burner pressure - min.	mbar	0.5	0.5	0.6
Differential burner pressure - CH	mbar	2.0	4.22	6.4
Factory set max. CO ₂ (± 0.5%)				
CO ₂ maximum - CH output	%	10.6	10.6	10.6
CO ₂ minimum output	%	9.8	9.8	9.8
Maximum CO/CO ₂	Ratio	0.003	0.003	0.003

2.3 PHYSICAL DATA

		CD 13R	CD 18R	CD 24R
Boiler flow connections	mm	22	22	22
Boiler return connections	mm	22	22	22
Gas connection diameter	mm	15	15	22
Boiler dimensions				
Height	mm	600	600	600
Width	mm	390	390	390
Depth	mm	305	305	305
Clearances for servicing				
Bottom	mm	100	100	100
Top (horizontal flue)	mm	235	235	235
Top (vertical flue)	mm	150	150	150
Sides	mm	5	5	5
Front	mm	450	450	450
Recommended hole size for flue pipe	mm	110	110	110
Boiler dry lift weight	kg	27	27	28
Boiler operating weight (full of water) approx.	kg	28	28	29
Max. total flue length				
Horizontal	m	12	12	12
Vertical	m	14	14	14
Flue system diameter	mm	60/100	60/100	60/100

2.4 FLUE LENGTHS

CD Easy-Flue 500 mm with terminal and 90° bend. A CD Easy-Flue 1000 mm with terminal and 90° bend is also available. CD 750 mm and CD 1000 mm flue extensions are available.

Length of Flue Required:-

Rear Flue (includes terminal) = wall thickness + 170 mm (or 140 mm for CD24R)

Side Flue (includes terminal) = wall thickness + distance between wall and side of boiler + 200 mm

Vertical Flue = distance from top of boiler side panel to required roof position minus 1000 mm for vertical terminal assembly

Maximum horizontal flue length = 12 m.

Maximum vertical flue length including terminal is 15 m.

Each additional CD 90° Bend is equivalent to 1.3 m of flue length.

Each CD 45° Bend is equivalent to 0.9 m of flue length.

The CD Vertical Flue terminal assembly is equivalent to 1 m of flue length.

2.5 PRESSURE LOSS ACROSS BOILER

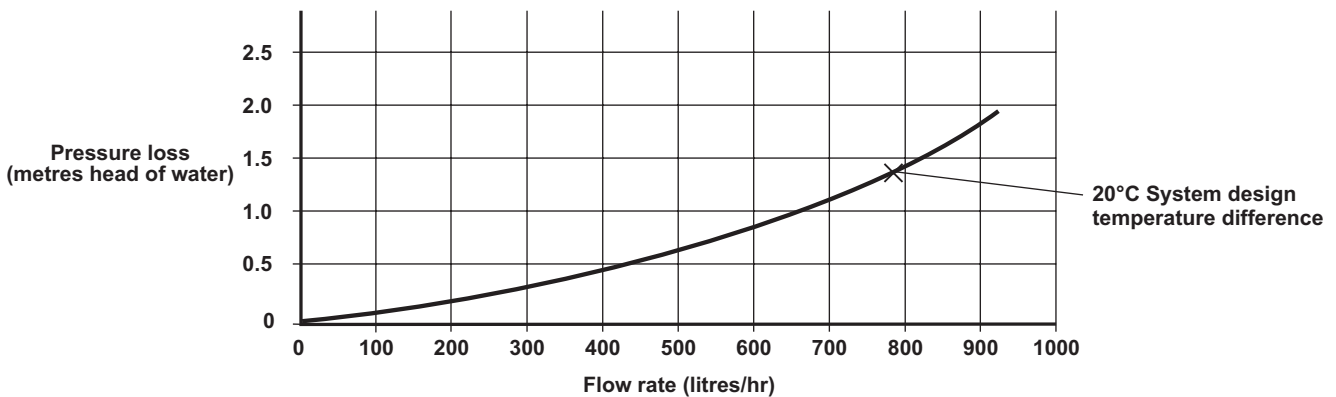

Fig. 2.1

2.6 ELECTRICAL CONNECTIONS

Note: This Appliance Must Be Earthed

An optional integral two channel Clock kit (Part No. 6.1000220) is available if required.

Note: Only use the Alpha two channel clock. Do not fit any single channel clocks.

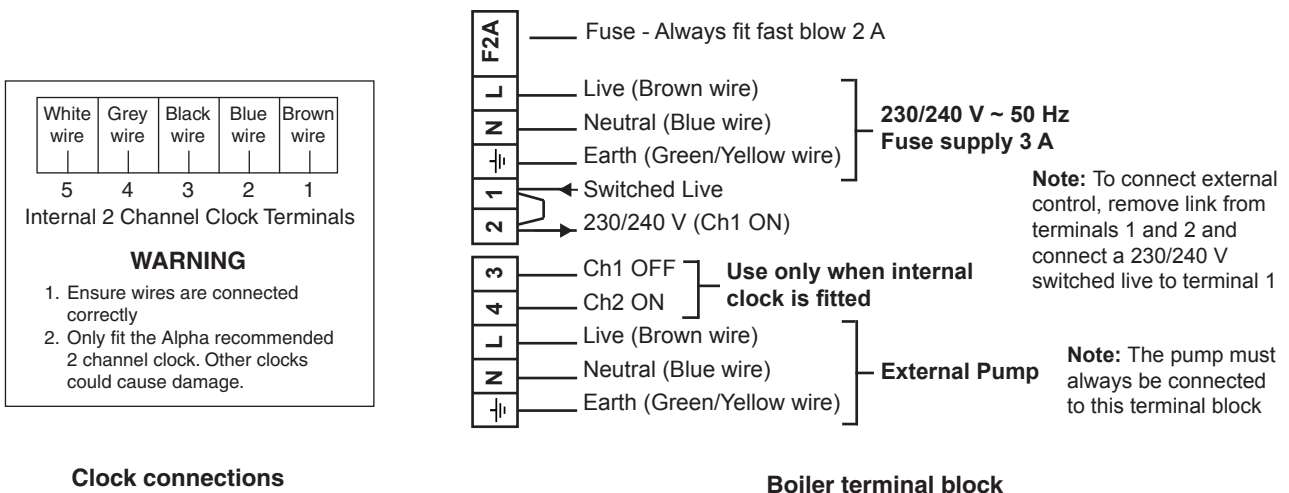
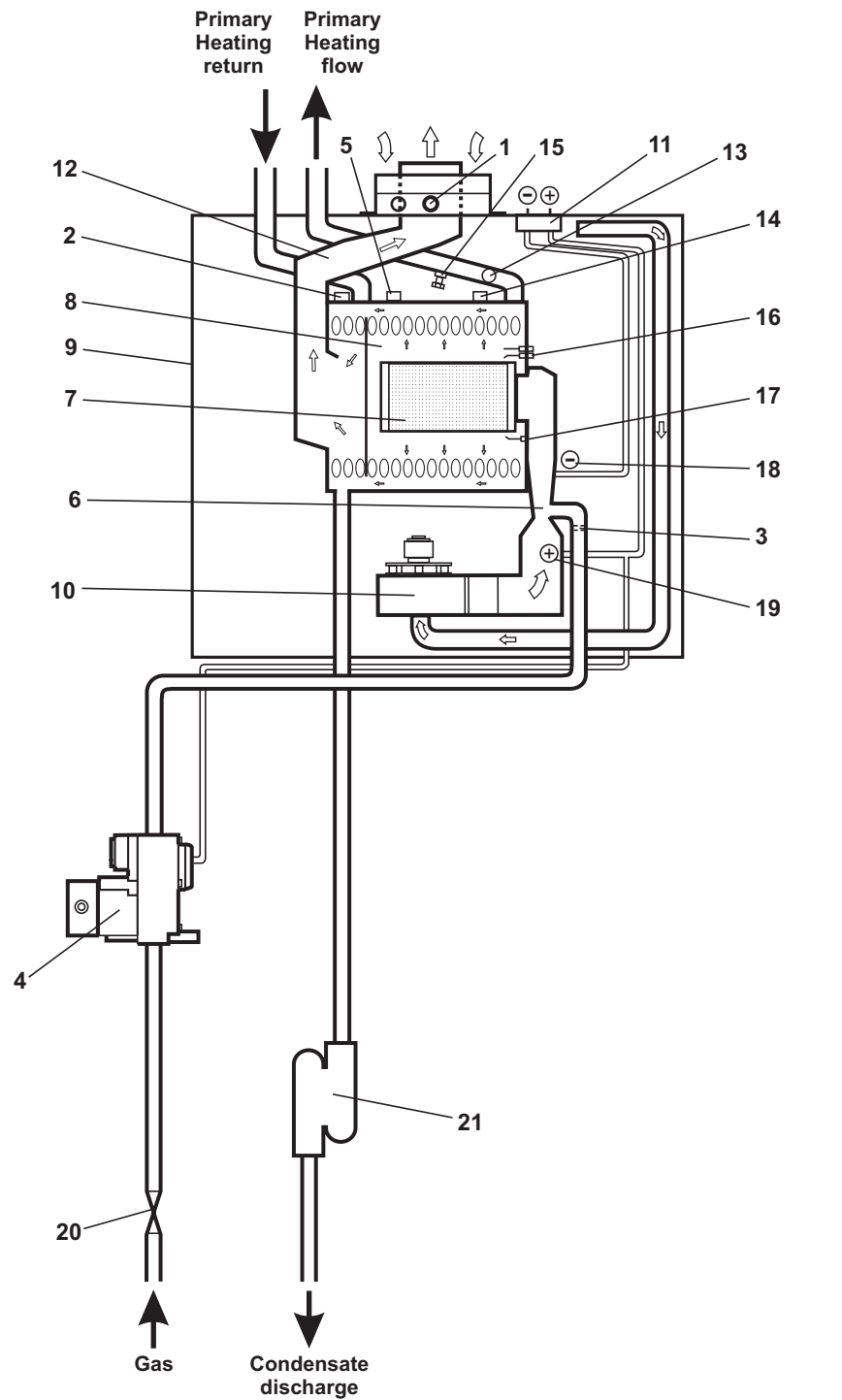

Fig. 2.2

2.7 BOILER SCHEMATIC



- | | |
|--|--------------------------------------|
| 1 - Flue sampling point | 12 - Flue hood |
| 2 - Flue thermostat | 13 - Overheat thermostat |
| 3 - Injector | 14 - Primary flow temperature sensor |
| 4 - Gas valve | 15 - Drain point |
| 5 - Primary return temperature sensor | 16 - Ignition electrodes |
| 6 - Venturi | 17 - Flame sensing electrode |
| 7 - Main burner | 18 - Venturi negative point |
| 8 - Primary/condensing heat exchanger | 19 - Venturi positive point |
| 9 - Room sealed chamber | 20 - Gas service cock |
| 10 - Fan | 21 - Condensate trap |
| 11 - Pressure differential test points | |

Fig. 2.3

3 GENERAL BOILER INFORMATION

3.1 GAS SUPPLY

The CD 13R boiler requires a gas rate of 1.31 m³/h (46.2 ft³/h).

The CD 18R boiler requires a gas rate of 1.94 m³/h (68.5 ft³/h).

The CD 24R boiler requires a gas rate of 2.54 m³/h (89.7 ft³/h).

The meter and supply pipes must be capable of delivering this quantity of gas in addition to the demand from any other appliances in the house. The CD 13R and CD 18R require at least a 15 mm gas supply pipe and the CD 24R requires a 22 mm gas supply pipe.

The complete installation, including the meter, must be tested for gas soundness and purged as described in BS 6891.

3.2 ELECTRICAL SUPPLY

The boiler requires a 230/240 V ~ 50 Hz mains supply, fused at 3 A

The boiler must be earthed.

There must only be one common isolator, providing complete electrical isolation, for the boiler and any external controls.

This boiler has been fitted with a supply cable, however, if it is necessary to fit a cable use PVC insulated cable not less than 0.75 mm² (24 x 0.2 mm) to BS 6500 Table 16. The boiler should be connected to a fused three pin plug and unswitched shuttered socket outlet (both complying with BS 1363), or a fused double pole switch with a contact separation of at least 3 mm in both poles.

Wiring external to the boiler must be in accordance with the current IEE Wiring Regulations (BS 7671).

Note: If a room thermostat is fitted, it must be suitable for 230/240 V switching.

3.3 AIR SUPPLY

The boiler does not require any air vents for cooling in the room in which it is installed or when installed in a cupboard or compartment. The minimum clearances for servicing must always be maintained.

Note: A cupboard or compartment used to enclose the boiler must be designed and constructed specifically for the purpose, i.e. comply with the Building Regulations.

3.4 FLUE SYSTEM - Fig. 3

The flue system must be installed in accordance with BS 5440:1.

For horizontal flues ensure the flue assembly is horizontal and the inner duct is sloping downwards towards the boiler.

Flue components are available as follows:-

CD Easy-Flue 500 mm (includes 90° bend and terminal) - Part No. 6.2000510.

CD Easy-Flue 1000 mm (includes 90° bend and terminal) - Part No. 6.2001010.

CD 750 mm flue extension - Part No. 6.2000750.

CD 1000 mm flue extension - Part No. 6.2001050.

CD 90° bend - Part No. 6.2000590.

CD 45° bend - Part No. 6.2000545.

CD Vertical flue terminal assembly. Refer to the separate installation instructions supplied with the assembly.

The following methods determine the correct length of flue required.

For rear exit flue (including terminal) $L = B + 170 \text{ mm}$ (or 140 mm for CD 24R)

For side exit flue (including terminal) $L = B + C + 200 \text{ mm}$ (min. side clearance required is 5 mm)

For vertical flue $L = H \text{ minus } 1000 \text{ mm}$ for vertical terminal assembly

Where $L =$ Required flue length

$B =$ Finished wall thickness

$C =$ Distance from the inside wall to the side of the boiler

$H =$ Distance from top of boiler side panel to roof position

Note: 1. If an extra 90° bend is used, this reduces the maximum flue length by 1.3 m. Each 45° bend used reduces the maximum flue length by 0.9 m.

2. Under no circumstances must the flue length (including allowances for extra bends) exceed 12 metres horizontally and only 15 metres vertically.

3. Failure to use Alpha CD flue components with the boiler will invalidate the boilers CE approval, guarantee and may be unsafe.

4. Further Plume management flue accessories are available - Refer to the Easy-Flue installation instructions.

HORIZONTAL FLUE OPTIONS - L_{max} = 12 metres

$L = B + C + 200 \text{ mm}$

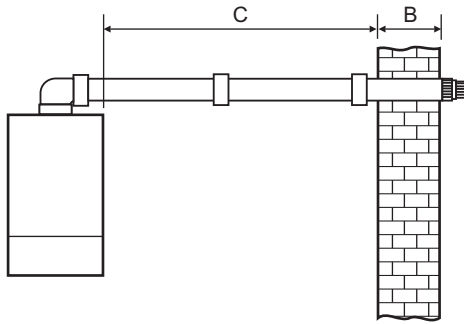

$L = B + C + E + 200 \text{ mm}$

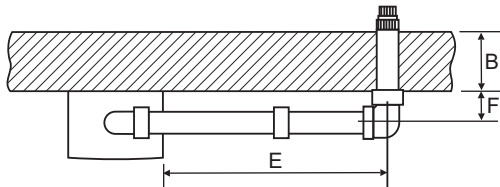
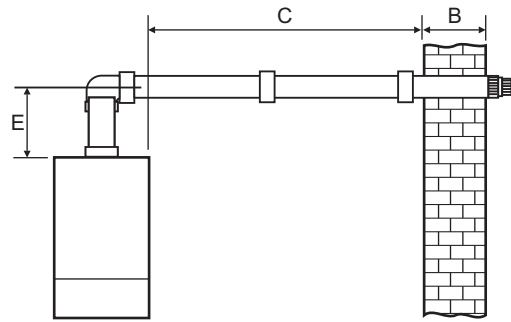

$L = B + E + F + 200 \text{ mm} + (90^\circ \text{ bend} = 1.3 \text{ metre})$

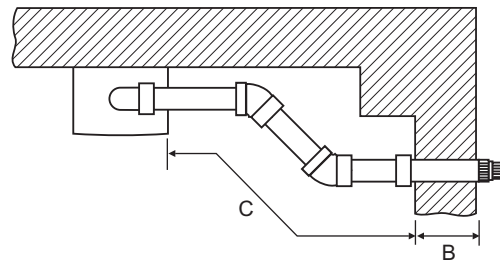

$L = B + C + 200 \text{ mm} + (2 \times 45^\circ \text{ bends} = 1.8 \text{ metre})$

VERTICAL FLUE OPTIONS

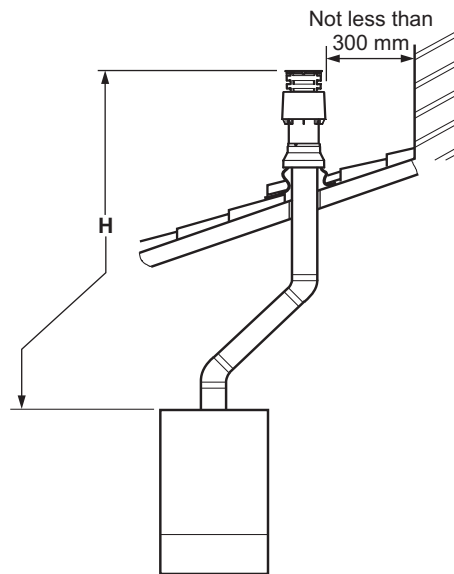
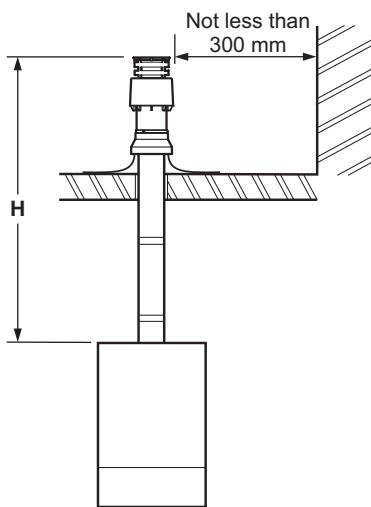

Fig. 2.4

3.5 FLUE TERMINAL LOCATION - Figs. 2.5 and 2.6

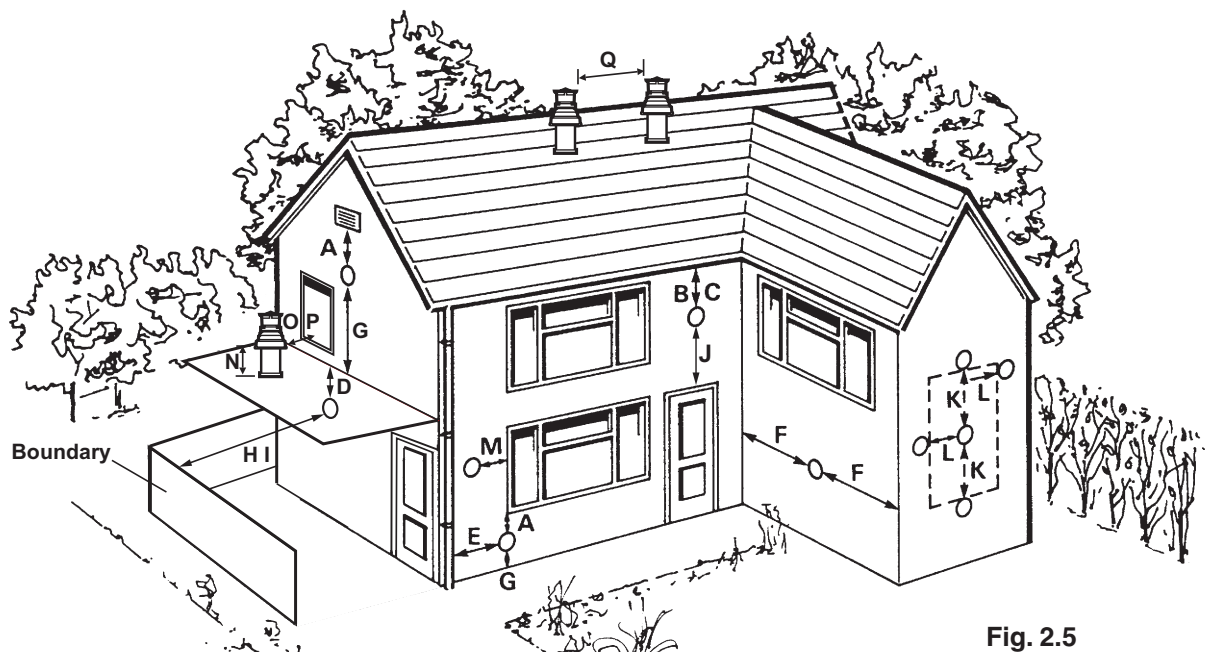

Fig. 2.5

Terminal position	Min. distance (mm)
A Directly below an opening, air brick, windows, etc.	300 (See Note 1)
B Below gutters, soil pipes or drain pipes	75 (See Note 3)
C Below eaves	200 (See Note 3)
D Below balconies	200 (See Note 3)
E From a vertical drain pipe or soil pipe	150 (See Note 3)
F From an internal or external corner	300 (See Note 2)
G Above ground, roof or balcony level	300
H From a surface or boundary facing the terminal	600 (See Note 4)
I From a terminal facing the terminal	1200 mm
J Above an opening, air brick, window etc.	300 (See Note 1)
K Vertically from a terminal on the same wall	1500 mm
L Horizontally from a terminal on the same wall	300 mm
M Horizontally from an opening, air brick, window etc.	300 mm (See Note 1)
N Minimum protrusion through a roof	300 mm
O From a vertical obstruction	300 mm
P From an openable window	600 mm
Q From an adjacent vertical terminal	600 mm

Notes:

- In addition, the terminal should not be nearer than 150 mm to the framework of an opening into the building, i.e. a window surround or door surround.
- This clearance may be reduced to 25 mm without effecting the performance of the boiler. However, to ensure the condensate plume does not affect adjacent surfaces a clearance of 300 mm is preferable.
- These clearances may be reduced to 25 mm without effecting the performance of the boiler. However, to ensure the condensate plume does not affect adjacent surfaces the terminal can be extended beyond gutters, pipes, eaves, balconies etc. by upto 500 mm. If the flue is extended more than 500 mm outside, it should be boxed and insulated.
- To reduce the possibility of nuisance to neighbouring buildings etc. it is recommended the terminal should not be less than 2500 mm from car parking spaces, building boundary walls, fences etc.
- A terminal must not be sited under a car port roof.
- In certain weather conditions the terminal will emit a plume of steam. If possible avoid positioning the terminal where this may cause a nuisance, i.e. positions A, D, G, H, J or M.
- The flue terminal must be exposed to the external air and the position must allow the free passage of air across it at all times.
- A terminal must not be sited below 2 m where people have access to, such as public footpaths, access routes, patios etc. However, if the terminal is fitted less than 2 m above a surface where there is no public access, the terminal must be protected by a terminal guard. A suitable guard is available from Alpha Therm Ltd.

Proximity of flue duct outlets to boundaries

The flue duct shall be sited so that it is at least 600 mm (see Fig. 5) from the boundary line when facing it and at least 300 mm from the boundary line when running parallel to it.

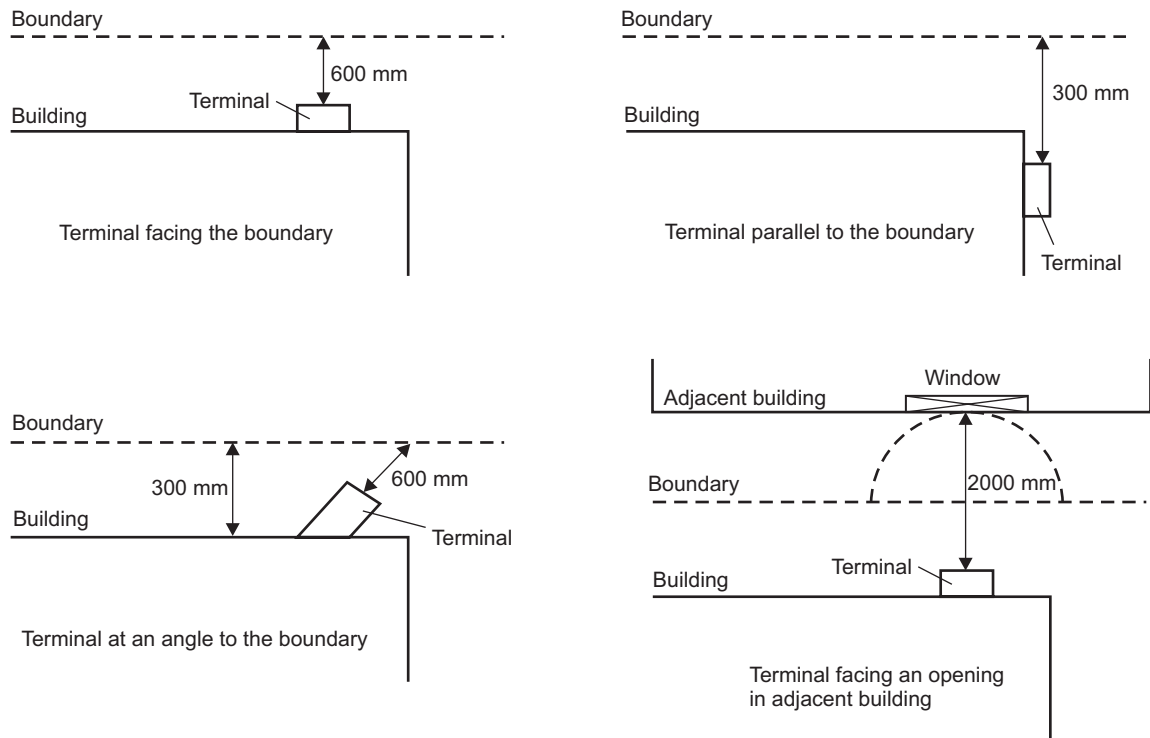

Fig. 2.6

3.6 BOILER LOCATION

The boiler is not suitable for external installation, unless it is installed within a purpose designed weatherproof building. The boiler must be installed on a flat vertical wall which is capable of supporting the weight of the boiler. The boiler can be fitted to or adjacent to a wall comprising of a combustible material without the need for a special thermal insulation barrier. If the boiler is to be fitted in a timber framed building, it should be fitted in accordance with the Institute of Gas Engineers 'Guide for Gas Installations in Timber Frame Housing', reference IGE/UP/7.

The boiler may be installed in any room or internal space, although particular attention is drawn to the requirements of the current IEE Wiring (BS7671) Regulations, and in Scotland, the electrical provisions of the Building Regulations applicable in Scotland, with respect to the installation of the boiler in a room or internal space containing a bath or shower. Where a room-sealed boiler is installed in a room containing a bath or shower, it must not be possible for a person using the bath or shower to touch any electrical switch or boiler control utilising mains electricity.

The boiler may be installed in a cupboard or compartment, provided it is correctly designed for that purpose, i.e. complies with the Building Regulations and the requirements of BS 6798.

3.7 CENTRAL HEATING SYSTEM - Fig. 2.7 and 2.8

The boiler is designed for use in an open or (if the alpha sealed system kit is used) sealed central heating system in accordance with the requirements of BS 5449 and BS 6798.

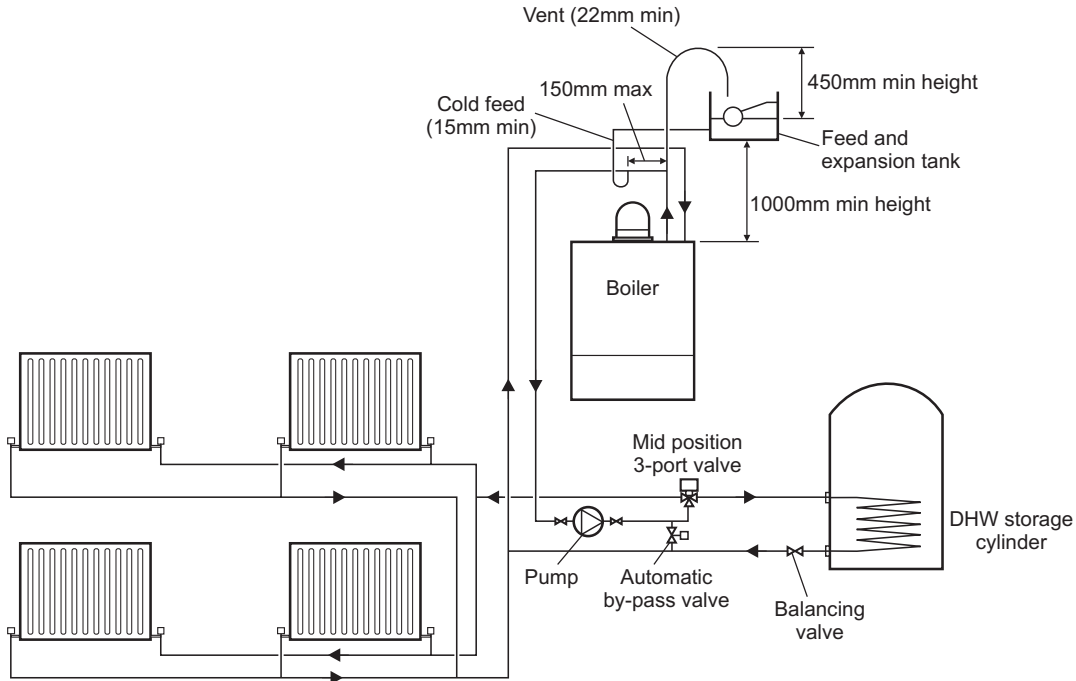

Fig. 2.7 - Open system with Y-Plan

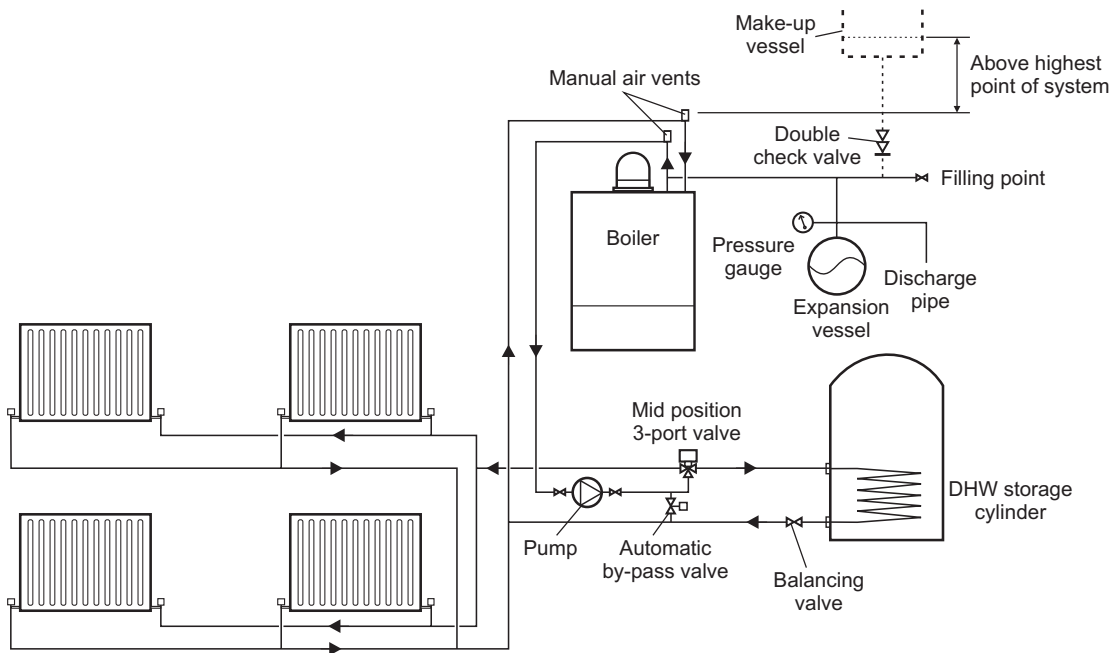

Fig. 2.8 - Sealed system with Y-Plan

3.8 FILLING THE OPEN VENTED CENTRAL HEATING SYSTEM

A minimum head of 1 m is required between the boiler/pump and the feed and expansion tank.

The boiler must be supplied from an unrestricted water supply taken from a feed and expansion cistern situated at a maximum height of 27 m above the boiler.

The cold feed must be 15 mm minimum size. The vent should be 22 mm in size, rise continuously and be unrestricted.

It is important that the relative positions of the pump, cold feed and open vents are as shown in Fig. 2.7.

The domestic hot water cylinder must be of the fully indirect coil type.

3.9 FILLING THE SEALED CENTRAL HEATING SYSTEM - Figs. 2.9 and 2.10

The system design pressure (cold) should be set to 1.0 bar. This pressure is equivalent to a static head (see Fig. 2.7) of 10.2 metres of water.

Provision should be made to replace water lost from the system. This can be by manual or automatic means, as shown in Figs. 2.9 and 2.10. The position for connecting an automatic make-up vessel is indicated in Fig. 2.8. A double check valve assembly must be used, as shown in Fig. 2.10.

Filling of the system must be carried out in a manner approved by the local Water Undertaking. Where allowed, the system may be filled via a temporary connection as shown in Fig. 2.9. After filling, always disconnect the flexible hose of the filling loop.

All fittings used in the system must be able to withstand pressures up to 3 bar.

Drain taps (to BS 2879) must be used to allow the system to be completely drained.

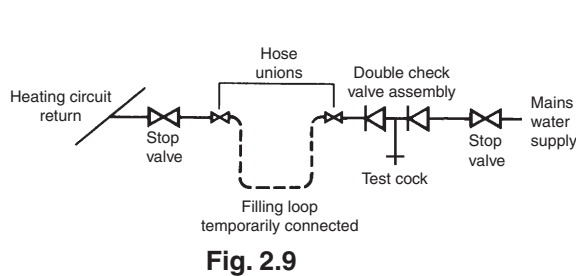

Fig. 2.9

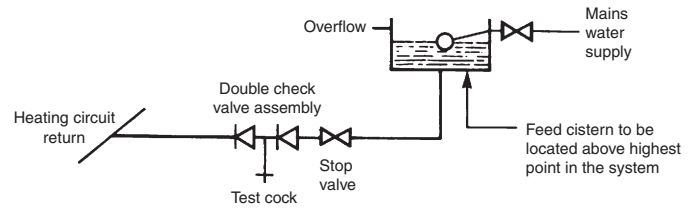

Fig. 2.10

3.10 FLUSHING THE HEATING SYSTEM

It is essential that the central heating system is thoroughly cleaned and flushed when fitting an Alpha CD boiler. Failure to do so will invalidate the warranty.

The primary and condensing heat exchanger is constructed in stainless steel and therefore is compatible with most materials used in a heating system.

If a cleaning agent and inhibitor are used, they must be applied in accordance with their manufacturers instructions. Only products from Fernox and Sentinel are acceptable for use with the Alpha CD boilers. Further information can be obtained from Fernox (Tel: 0870 8700362) or Sentinel (Tel: 0151 4209563).

The system should be flushed in accordance with BS 7593 and BS 5449. The following procedures are recommended:

1. Installing onto a new system:-
 - a. Fill the system, vent at high points, at pump and radiators.
 - b. Check for leaks.
 - c. Rapidly drain the system.
 - d. If required, chemically clean the system as instructed by the recommended cleaner manufacturer.
Note: Ensure that the system is flushed to remove any remains of the cleaner.
 - e. If chemical cleaner is not used to clean the system:-
 - i) Refill the system.
 - ii) Switch on the boiler and allow the system to heat up to the normal operating temperature.
 - iii) Rapidly drain the system while the water is still hot.
 - iv) Refill the system.
 - f. As required, add the recommended inhibitor to the system as instructed by the inhibitor manufacturer.
 - g. Recheck for leaks.
2. Installing onto an existing system, clean the system before fitting the new boiler:-
 - a. If the old boiler is still working:-
 - i) Switch on the boiler and allow the system to heat up to the normal operating temperature.
 - ii) Rapidly drain the system while the water is still hot.
 - iii) Refill and chemically clean the system as instructed by the recommended cleaner manufacturer.
 - iv) Ensure the system is flushed to remove any remains of the cleaner.
 - v) Fit the new boiler.
 - b. If the old boiler is not working:-
 - i) Rapidly drain the system.
 - ii) Remove the old boiler.
 - iii) Flush the system through.
 - iv) Fit the new boiler.
 - v) Refill and chemically clean the system as instructed by the recommended cleaner manufacturer.
 - vi) Ensure the system is flushed to remove any remains of the cleaner.
 - c. As required, add the recommended inhibitor to the system as instructed by the inhibitor manufacturer.
 - d. Check for leaks.

3.11 DISPOSAL OF CONDENSATE

Provision must be made for the safe disposal of condensate produced by the flue gases of the Alpha CD boilers and reference should be made to BS 6798: 2000 for the requirements on the disposal of condensate.

The boilers incorporate a condensate trap which has a seal of 75 mm, therefore no additional trap is required.

The condensate should ideally be discharged internally into an internal waste pipe (washing machine/sink waste) or soil pipe to avoid the possible risk of freezing. The pipework must be in 22 mm pipe.

External pipe runs should be avoided, but if it is necessary, the pipework should be protected from the risk of freezing with waterproof insulation and the length should be kept to a maximum of 3 m. Alternatively the condensate pipework could be increased to a minimum of 32 mm diameter without the requirement to insulate the pipework. Termination should be into an external gully or soakaway as shown in Figs. 2.11 and 2.12.

Note: All pipework must have a continuous fall (see Figs. 2.11 and 2.12) from the boiler and must be of an acid resistant material such as plastic waste pipe. (copper or steel is not suitable).

It should be noted that the connection of a condensate pipe to a drain may be subject to local building control requirements.

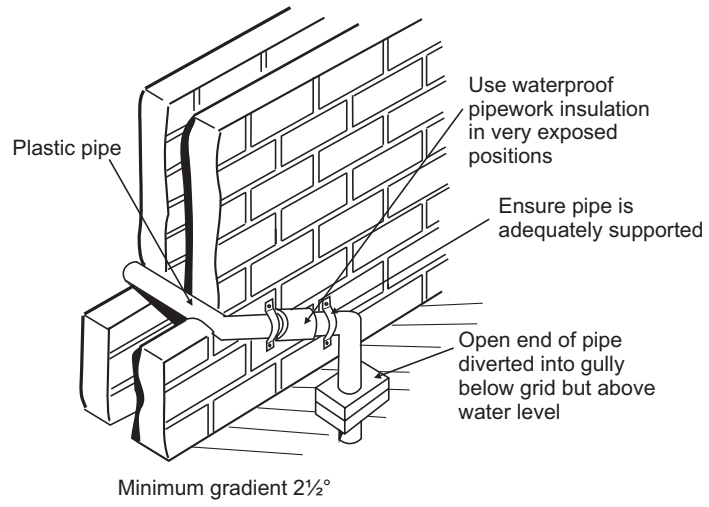

Fig. 2.11 - External gully

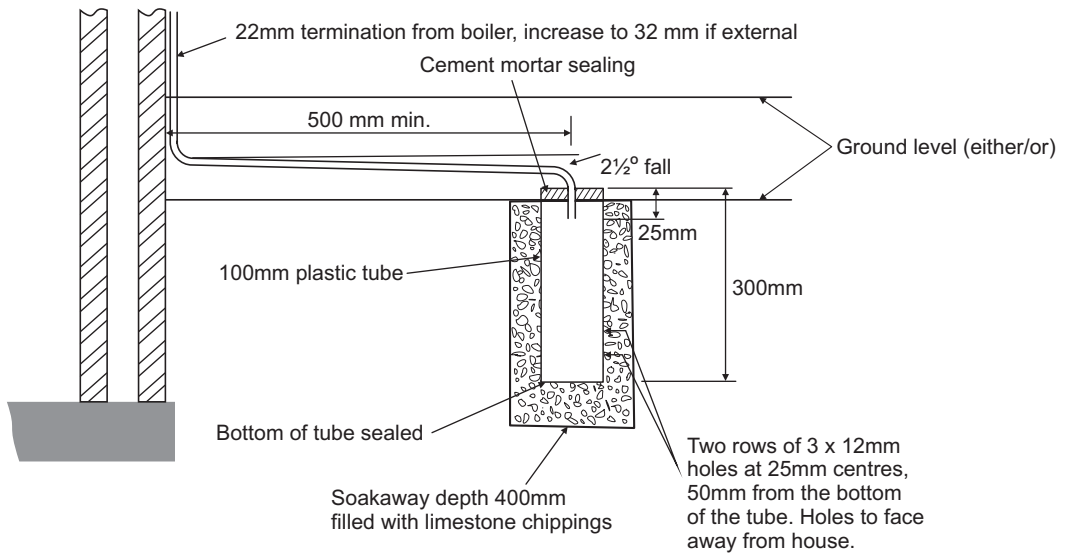

Fig. 2.12 - External soakaway

4 INSTALLATION

4.1 UNPACKING

- The boxes required when the boiler is installed with a horizontal flue are as follows:-

Box 1 Cased boiler fitted with gas isolation valve, gas union and washers
Mounting bracket plus screws and wall plugs, 15 mm gas union bend
Literature pack and Wall template

Box 2 CD Easy-Flue 500 mm or CD Easy-Flue 1000 mm. Both include 90° bend and horizontal flue terminal
Note: NOT required for vertical flue

Notes: a. All flues must be suitable for CD condensing boilers.
b. CD 750 mm and 1000 mm flue extensions are available, if required.

- Unpack boiler and remove the loose items packs and mounting bracket.

Note: To prevent any damage being caused, ensure the gas union bend is removed before standing the boiler in an upright position.

4.2 CLEARANCES REQUIRED - Fig. 4.1

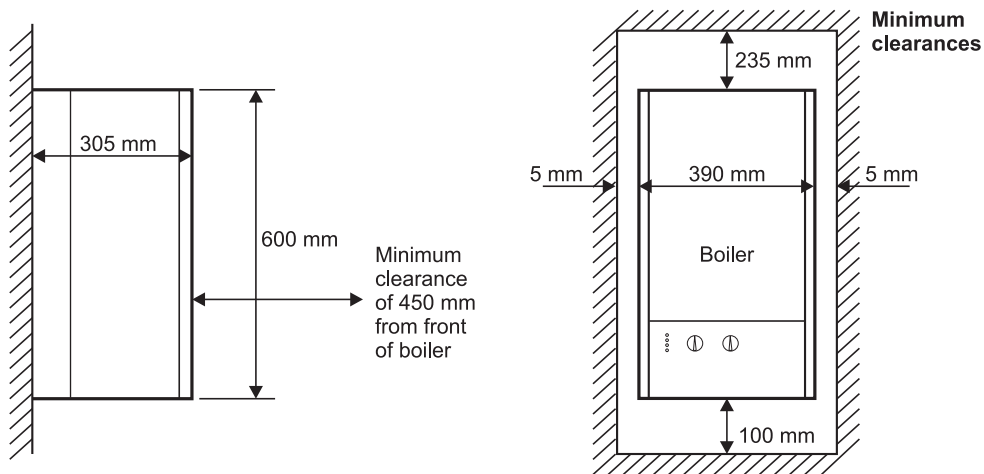

Fig. 4.1

4.3 PREPARE THE WALL - Figs. 4.2 and 4.3

- Decide upon the position of the boiler taking into account the clearances required for servicing and the flue terminal position.
- Tape the template to the wall (ensure it is level and the right way up) and mark the position of the holes for the boiler mounting bracket and bottom fixings. If rear exit flue is used, mark the position of the hole for the flue.

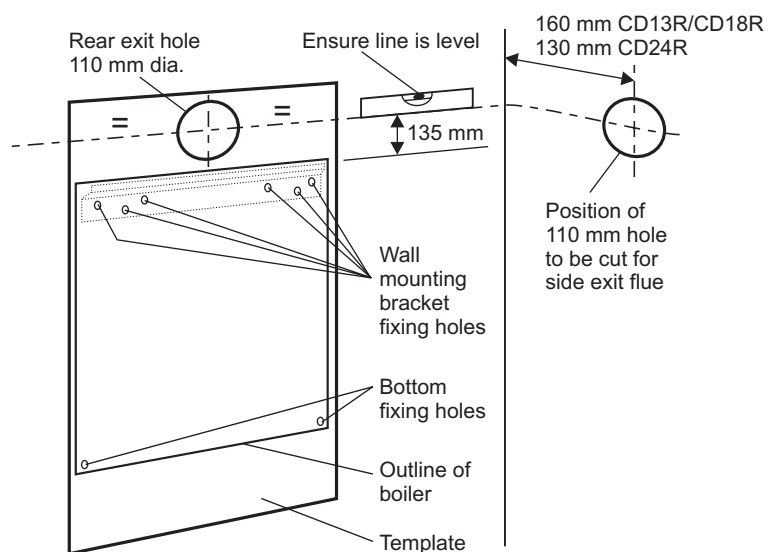

Fig. 4.2

- Side exit flue** - Continue the horizontal centre line of the flue across the wall to the side wall, then along the side wall 160 mm for the CD 13R and CD 18R or 130 mm for the CD 24R (ensure the lines are horizontal). This will give the position of the centre of the hole for the flue.

- Cut the 110 mm diameter hole (or use a 107 mm core drill) in the wall for the flue.

Notes: a. Ensure the hole is horizontal.
b. **For internal fitting** of the flue, using the flue sealing collar supplied, cut a 130 mm dia. flue hole using a 127 mm core drill.

- Drill the fixing holes (10 mm dia.) to accept the No. 10 plugs supplied. Using the screws supplied, fit the mounting bracket.

4.4 FIT THE BOILER - Refer to Fig. 4.2

1. Lift the boiler and locate it on the mounting bracket. Fit the bottom screws to secure the boiler in position.

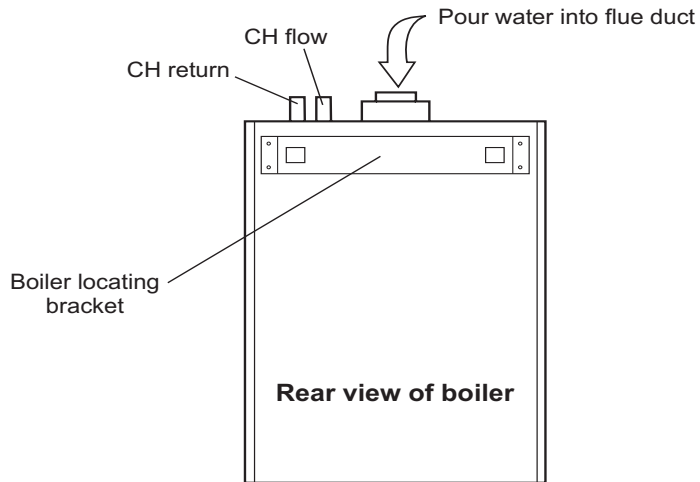

Fig. 4.3

4.5 CONNECT THE PIPEWORK - Fig. 4.4

1. Thoroughly flush out all the water pipework. Refer to Section 3.9.
2. The gas isolation valve has been factory fitted, however, check that the connections underneath the boiler have been tightened.

Note: When soldering to the boiler union bend, ensure the bend is not connected to the valve, otherwise the internal seals may be damaged.
3. Connect the system pipework to the boiler.

Note: Ensure the flow and return pipes are correctly connected to the boiler. Refer to Fig. 4.4.
4. Connect the 22 mm condensate trap drain pipe to the condensate discharge pipe. Ensure that the condensate discharge pipe is as required in Section 3.11. Pour at least 0.5 litre of water into the flue duct, as shown in Fig. 4.3, and check the condensate discharge pipe for soundness.
5. Ensure that the gas isolation valve is closed (spindle flats at right angles to valve) and do not turn on the gas supply at this stage.

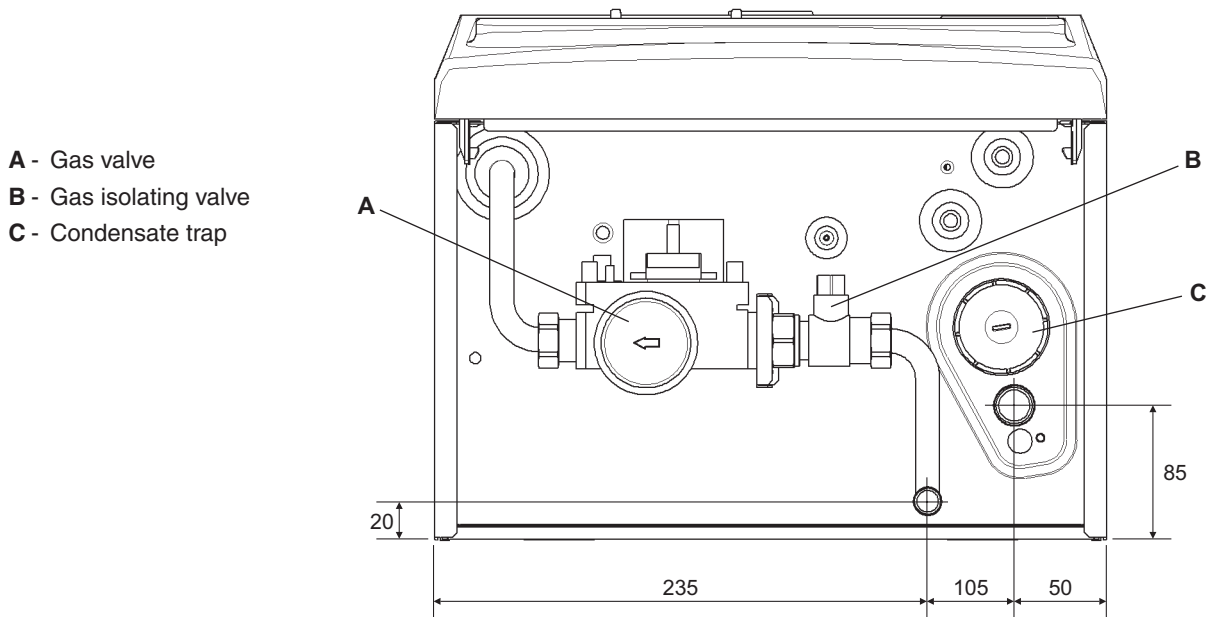

Fig. 4.4

4.6 FIT THE FLUE - Figs. 4.5 and 4.6

The following procedure applies to fitting an Alpha CD Easy-Flue to both rear or side exit flue - horizontally only.

- The CD Easy-Flues are suitable for use in the flue length ranges shown in the tables below.

Note: Where the length is less than the minimum or more than the maximum, refer to Section 4.7.

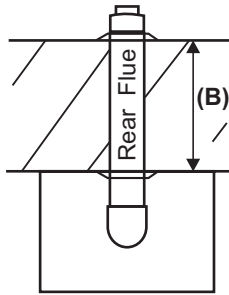

Fig. 4.5

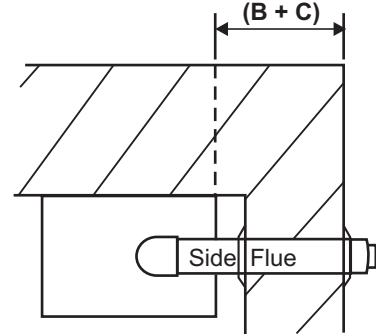

Fig. 4.6

CD Easy-Flue	B (mm)			
	Max		Min	
	13R/18R	24R	13R/18R	24R
500 mm	515	545	325	355
1000 mm	960	990	750	780

CD Easy-Flue	B + C (mm)	
	Max	Min
500 mm	475	285
1000 mm	920	710

- Determine the overall length (L) of flue required, (see Fig. 4.7) as follows:-

Rear flue $L = \text{wall thickness (B)} + 90 \text{ mm for CD 13/18R or } 60 \text{ mm for CD 24R}$

Side flue $L = \text{wall thickness (B)} + \text{distance between boiler and wall (C)} + 120 \text{ mm}$

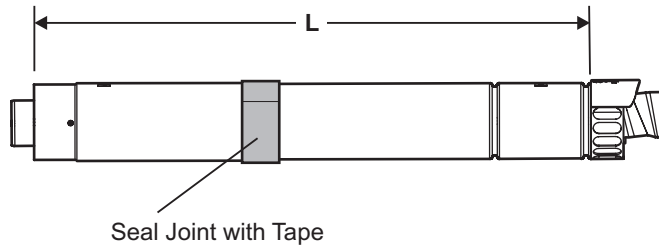

Fig. 4.7

- Adjust the telescopic section of the flue to the distance 'L', ensuring that the two labels marked 'TOP' are aligned, then seal and secure the joint between the ducts with the sealing tape supplied.

- Pass the flue assembly through the wall (from inside or outside).

Note: Internal fitting - If there is no access to make good the outside wall, locate the flue sealing collar onto the outer duct of the flue immediately before the terminal grille onto the location provided. Push the flue assembly through the 130 mm flue hole, so that the collar completely passes through the wall. Then pull the flue assembly back into the correct position. Visually check that the collar is sealing the outside wall and that it is not restricting any of the openings of the flue terminal.

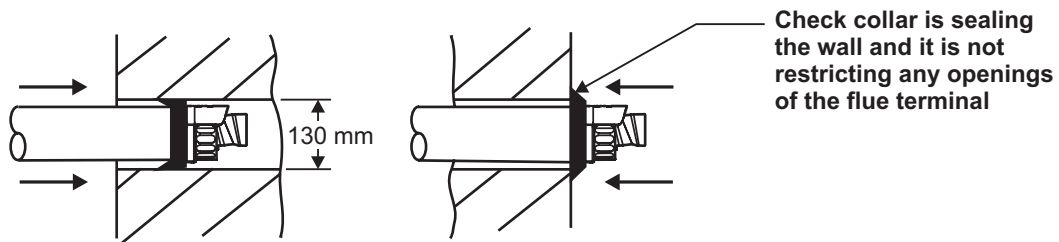

Fig. 4.8 - Fitting the flue from inside

- Position the seal and clamp (two screws) supplied, over the bend. Fit the bend to the boiler and rotate to the correct position. Secure in position using the seal and clamp, ensuring the seal is located centrally over both the bend and boiler adaptor.
- Fit the inside flue sealing collar over the Easy-Flue. Fit the outside flue sealing collar onto the flue immediately before the terminal grille onto the location provided.

- f. Slide the clamp (three screws) over the outer duct and pull the flue assembly towards the bend, locating the inner duct into the seal joint on the bend. Ensure the labels marked 'TOP' are positioned at the top before securing the flue assembly to the bend with the clamp (three screws) located centrally over the joint.
Note: Check the flue terminal protrudes 90 mm out of the wall and the inner duct of the terminal is positioned correctly (see Fig. 4.9).
- g. Make good the inside wall by pushing the inside flue sealing collar up to the wall.

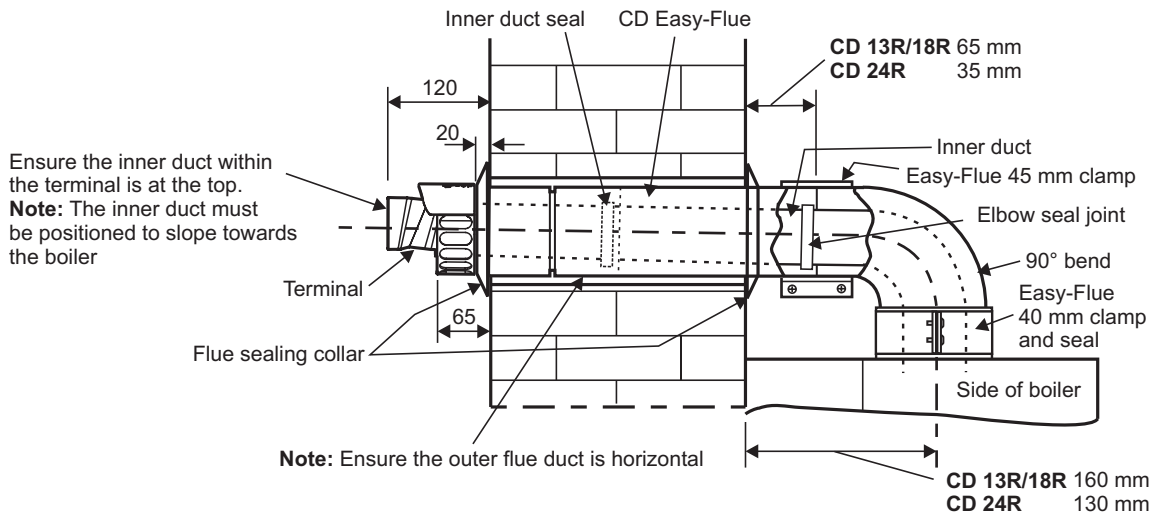
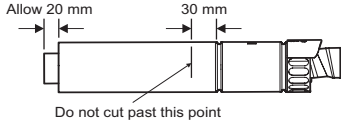
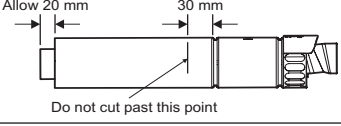

Fig. 4.9 - Rear flue

4.7 EXTENDING THE FLUE - Fig. 4.10

Note: The maximum horizontal flue assembly length must not exceed a length of 12 metres.

1. When the flue length required is more than the maximum or less than the minimum stated in Section 4.6, paragraph 1, refer to the table below.

Flue Length	Rear Flue (B)	Side Flue (B + C)	Comments
CD 13R/18R Up to:- CD 24R Up to:-	11.93 m max 11.96 m max	11.89 m max 11.89 m max	Alpha CD 750 mm or 1000 mm flue extension (Part No. 6.2000750 or 6.2001050) is required to extend the range of telescopic flue. Refer to Section 4.7 paragraph 2 for instructions on how to extend the flue. Note: A 130 mm flue hole (127 mm core drill) is required in the wall.
CD 13R/18R Between:- CD 24R Between:-	740 mm and 945 mm 770 mm and 975 mm	700 mm and 905 mm 700 mm and 905 mm	Within the standard Easy-Flue 1000 mm (Part No. 6.2001010) telescopic range.
CD 13R/18R Between:- CD 24R Between:-	95 mm and 685 mm 125 mm and 715 mm	55 mm and 645 mm 55 mm and 645 mm	Discard the first telescopic section of the Easy-Flue 1000 mm (i.e. not with terminal) and cut to the required length 
CD 13R/18R Between:- CD 24R Between:-	300 mm and 505 mm 330 mm and 535 mm	260 mm and 465 mm 260 mm and 465 mm	Within standard Easy-Flue 500 mm (Part No. 6.2000510) telescopic range.
CD 13R/18R Between:- CD 24R Between:-	95 mm and 245 mm 125 mm and 275 mm	55 mm and 205 mm 55 mm and 205 mm	Discard the first telescopic section of the Easy-Flue 500 mm (i.e. not with terminal) and cut to the required length. 
Less than above			Terminal may protrude somewhat from the outside wall.

2. Use the template (supplied with the boiler) to mark the required flue position and cut a 130 mm diameter hole for the flue (use a 127 mm core drill). The size of the hole provides sufficient clearance for the clamps on the flue extension to pass through the hole.
3. Determine the overall flue length as described in Section 4.6, paragraph 2 to determine the number of Alpha CD 750/1000 mm flue extensions required.
4. Assemble the flue extensions together by locating the inner duct into the seal joint and secure each extension together with the clamps supplied (three screws). Ensure that the clamps are positioned centrally over the joints.
Note: If it is required to cut an extension, **DO NOT** cut the end of the inner duct that incorporates the seal joint. Ensure the inner duct end without the seal joint is cut so that it is 15 mm longer than the outer duct.
5. Adjust the telescopic section of the Easy-Flue to the required length and secure the Easy-Flue with the sealing tape supplied. Fit the Easy-Flue to the extensions by locating the inner duct into the seal joint and secure with the clamp (three screws), ensuring it is located centrally over the joint.
6. Mark the end of the flue assembly 'TOP' where it is connected to the boiler, so that the 'TOP' of the flue terminal is aligned with the 'TOP' at the boiler end of the flue assembly.
7. Pass the complete flue assembly through the wall.
8. Position the seal and clamp (two screws) supplied, over the bend. Fit the bend to the boiler and rotate to the correct position and secure in position using the seal and clamp, ensuring that the seal is positioned centrally over both the bend and adaptor.
9. Slide the clamp (three screws) over the outer duct and pull the flue assembly towards the bend, locating the inner duct into the seal joint on the bend.
10. Secure the flue assembly to the bend with the clamp (three screws) ensuring it is positioned centrally over the joint, ensuring the 'TOP' marked on the outer duct is positioned at the top.
Note: Check the flue terminal protrudes 100 mm out of the wall and that the inner duct of the terminal is positioned correctly, i.e. the inner duct within the terminal is at the top. See Fig. 4.10.
11. Make good the outside wall by fitting a flue sealing collar onto the location provided immediately behind the flue terminal grille. Make good the inside wall as required.
Note: If flue sealing collars are being used to make good the inside wall, then they will need to be fitted before assembling the flue.

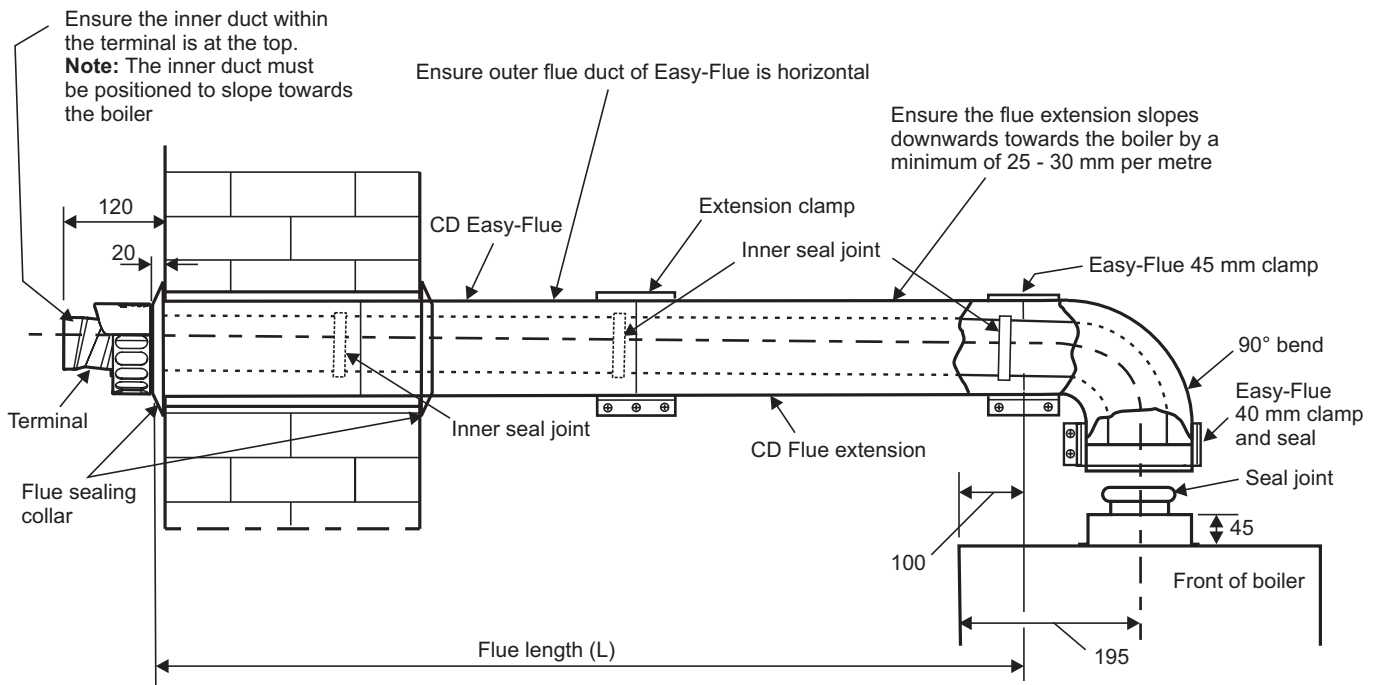

Fig. 4.10 - Side flue

4.8. FIT PLUME MANAGEMENT COMPONENTS - (OPTIONAL)

The following procedures detail the options for management of the exhaust flue gas/plume emitted from the terminal.

- a. The terminal supplied with the Easy-Flue can be altered to divert exhaust flue gas/plume at an angle. This can be achieved by simply turning the end section of the terminal to the desired angle.
- b. The CD Easy-Flue can be converted to allow the inner flue duct to be extended so as to position the terminal in an area where the exhaust flue gas/plume will not cause a nuisance. This can be done before or after installation of the flue, providing there is access to the terminal from outside.
 - i. Remove the screws (1 in Fig. 4.11) securing the terminal and remove the terminal by pulling it from the flue assembly. Remove the screw (2 in Fig. 4.11) securing the terminal end section and remove the end section from the terminal.
 - ii. Locate a 93° Plume Management bend into the flue assembly and rotate it to the direction required.
 - iii. Connect to the 93° bend the required Plume Management components as detailed and refer to Fig. 4.11.

Notes:

1. The wall support brackets must be used to secure the Plume Management pipework to the wall and prevent disconnection of the 93° bend from the flue assembly or any other component.
 2. Each joint must be secured with one of the screws provided to prevent accidental disconnection.
 3. Ensure there is always a slight slope towards the flue assembly fitted in the wall and there is no part of the plume management pipework where condensate/rain will collect and cause a blockage or any restriction.
- iv. Terminate the Plume Management pipework by fitting the terminal end section (push-fit) previously removed. Refer to Fig. 4.12.
 - v. The Plume Management components available for extending the inner flue duct are as follows:-
 - Plume Management 93° bend 60 mm dia. (each 93° bend equivalent to 1.3 m flue length)
 - Plume Management 45° bend 60 mm dia. (each 45° bend equivalent to 0.9 m flue length)
 - Plume Management 1000 mm extension 60 mm dia. (equivalent to 1 m flue length)
 - 60 mm dia. wall bracket

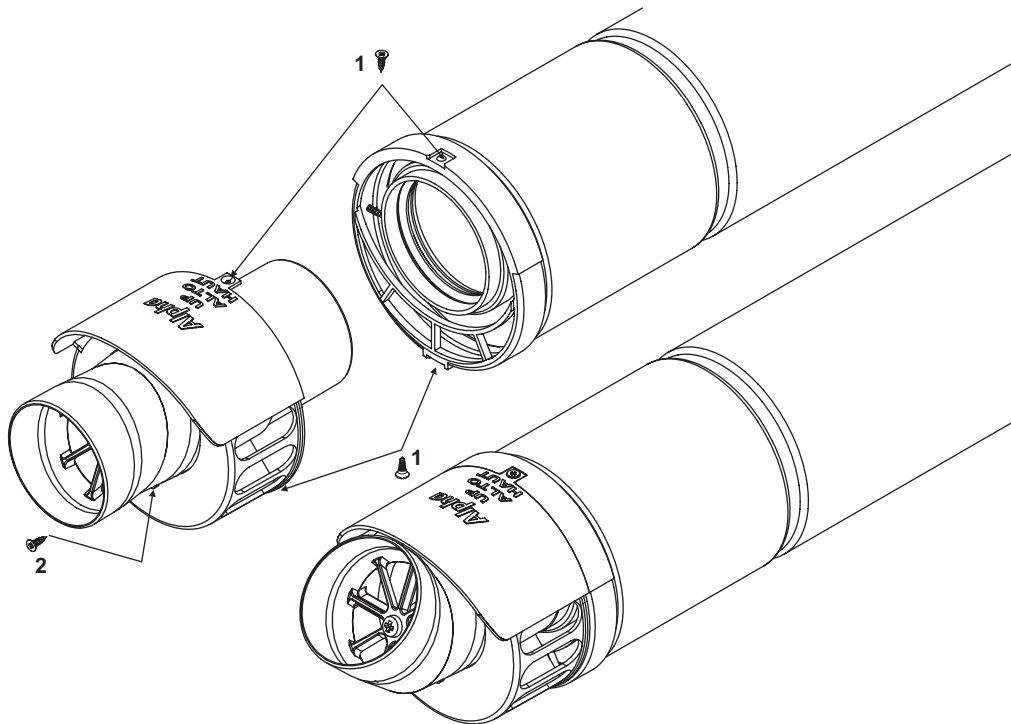

Fig. 4.11

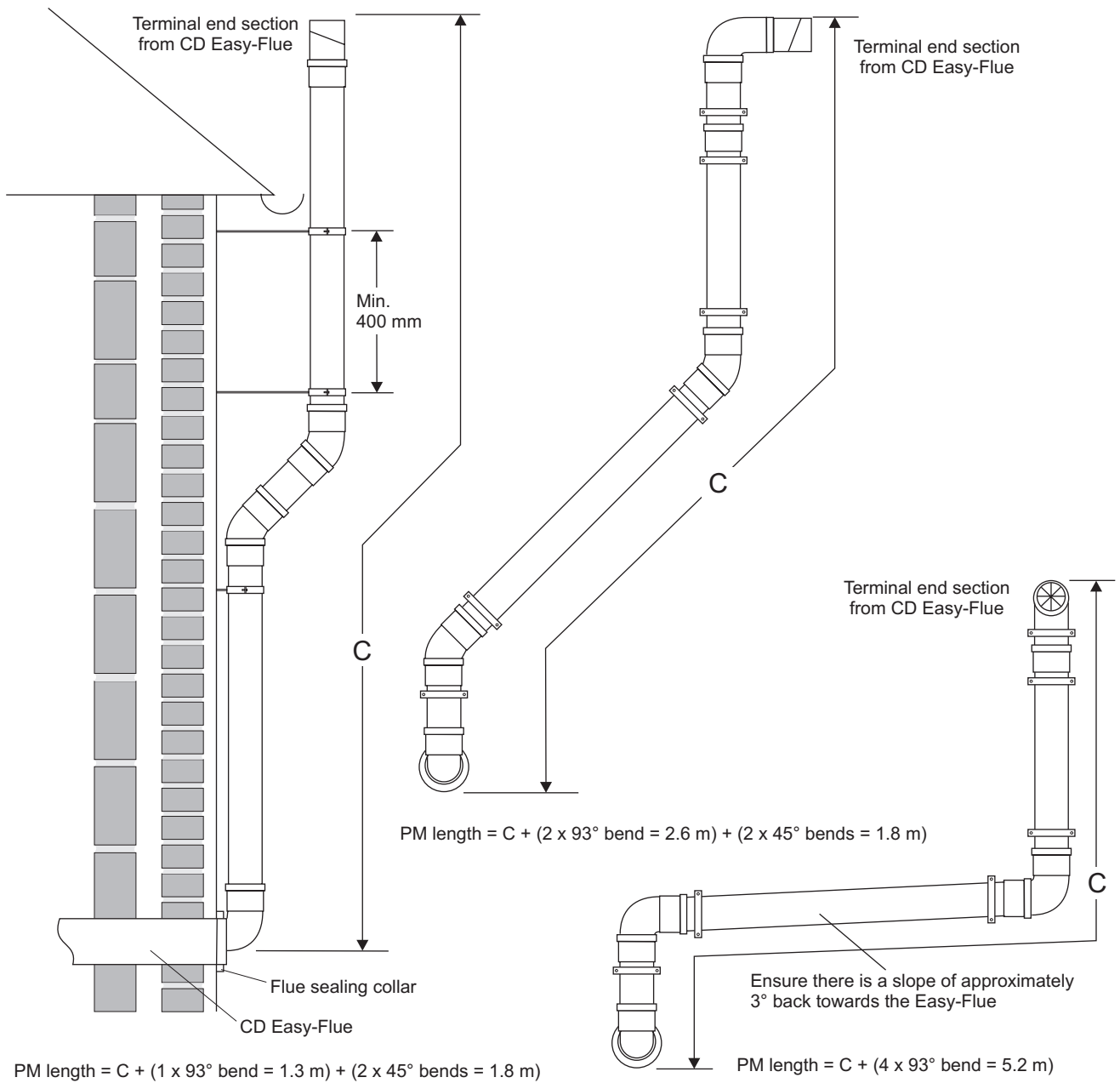

Fig. 4.12

Note: The equivalent horizontal flue assembly length + the equivalent plume management length (PM length) must not exceed the maximum flue length stated for each boiler, i.e.

Alpha Intec boiler maximum equivalent flue length must not exceed 12 metres.

4.9 CONNECT THE MAINS SUPPLY - Fig. 4.13

1. Gain access to the boiler terminal block by removing one screw at the top centre of the front panel, then lift up and remove panel. Release the two fixing screws (one each side) securing the control panel. Lower the control panel. Refer to Technical Data, Section 2.6 for connection details.

2. **Note:** This boiler has been fitted with a mains supply cable. However, if it is necessary to fit an alternative supply cable, ensure the cable clamp that has been fitted is removed and connect as follows:-

Remove the two screws securing the terminal block cover from the back of the control box (see Fig. 4.13). Pass the mains supply cable through the grommet and cable clamp and connect as follows:- Brown to L, Blue to N and Green/Yellow to \perp . Ensure correct polarity.

Note: Ensure that the length of the earth wire is such that if the supply cable is pulled out of its clamp the live and neutral wires become taut before the earth wire. The main terminal block can be removed by pulling it off the pins to give easy access to the terminals. Do not switch on the electrical supply at this stage.

3. If an external control, i.e. room thermostat or external clock is to be fitted, remove the terminal block cover and remove the link between terminals 1 and 2. Pass the cable through the cable clamp and connect it to terminals 1 and 2. Connect the external pump cable to the boiler terminal block by passing the cable through the cable clamp and connecting it to L, N and \perp terminals for the external pump. Replace the terminal block cover. (Refer to Section 2.6).

Note: Ensure the pump is always connected to the boiler terminal block.

4. Replace the terminal block, ensuring it is located correctly on the plastic pins and replace the cover.

5. Ensure that there is sufficient free cable to allow the control panel to be raised and lowered then tighten the cable clamp screws.

6. Leave the control panel open until commissioning procedures have been completed.

7. Carry out electrical system checks - Short circuit, Polarity, Earth continuity and Resistance to earth with a suitable multimeter.

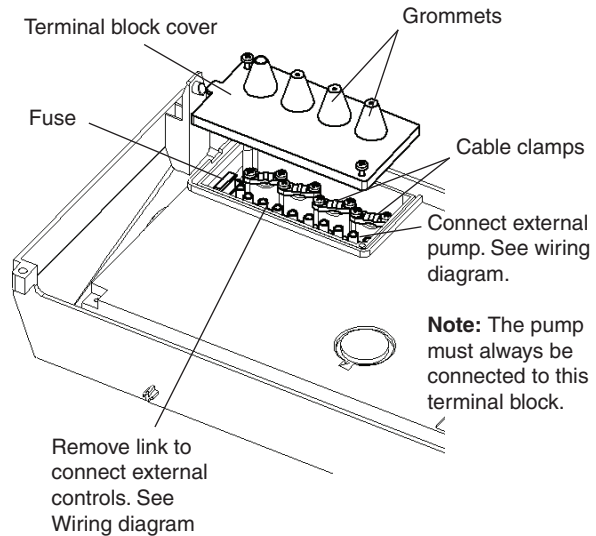

Fig. 4.13

4.9 FIT THE CLOCK KIT - Fig. 4.14

Ensure the electrical supply to the boiler is isolated.

Note: Only use an Alpha two channel clock. **Do not fit a single channel clock.**

1. Remove the two screws securing the clock cover at the rear of the control panel.

2. Remove and discard the clock blanking panel.

3. Insert the clock into the opening and secure in place with the screws supplied - do not overtighten the screws..

4. Disconnect the clock wiring from the terminal block and connect it to the clock as follows:-

Brown wire to terminal 1, Blue wire to terminal 2, Black wire to terminal 3, Grey wire to terminal 4 and White wire to terminal 5, (or as per the instructions supplied with the clock). Ensure wiring is correct.

Note: Before the clock is fitted, remove the link between terminals 1 and 3 on the clock wiring harness fitted to the boiler.

5. Replace the clock cover. Do not overtighten the fixing screws.

6. Leave the control panel open until commissioning procedures have been completed.

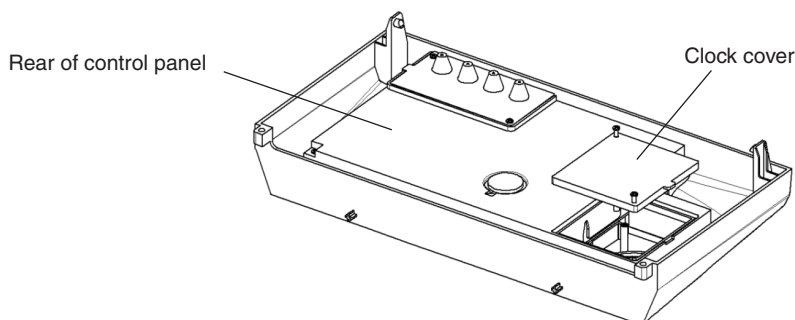

Fig. 4.14

5 COMMISSIONING

When commissioning the boiler, ensure the Benchmark Checklist is completed.

5.1 FILL THE SYSTEM

1. To remove the air - Vent each radiator in turn, starting with the lowest in the system.
2. It is important that the external pump is properly vented to avoid it running dry and damaging its bearings. Unscrew and remove the cap from the centre of the pump. Using a suitable screwdriver rotate the exposed spindle about half a turn, then replace the cap.
3. Refer to Sections 3.8, 3.9 and 3.10 for filling and flushing the system.
4. Ensure that the condensate trap has been filled with water. Refer to Section 4.5, paragraph 4.

5.2 BOILER CONTROLS - Fig. 5.1

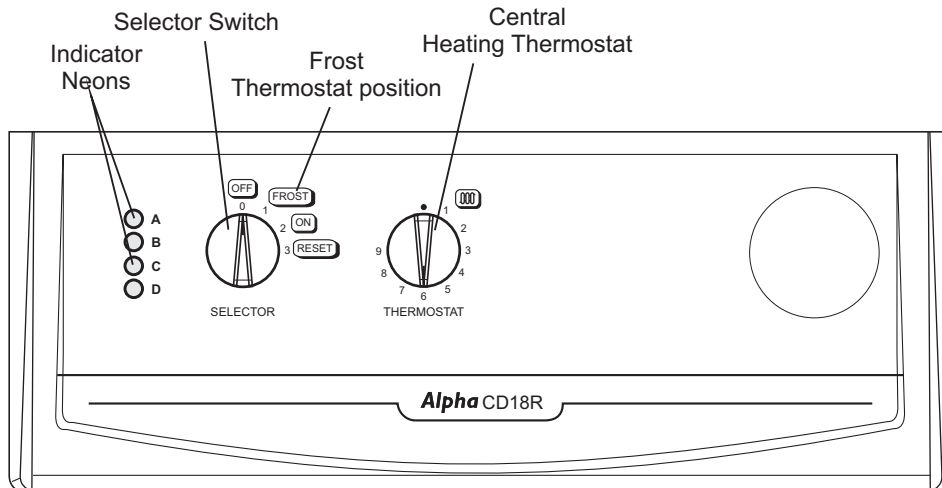

Fig. 5.1

5.3 TEST FOR GAS SOUNDNESS AND PURGE THE SUPPLY

1. With the boiler gas service cock closed (slot at right angles to valve). Pressure test the gas supply and inlet pipework connection to the boiler gas service cock for soundness in accordance with BS 6891.
2. Loosen the gas inlet pressure test point screw on the gas valve (see Fig. 5.3). Ensure the gas supply is on and open the boiler service cock to purge in accordance with BS 6891.
3. Retighten the test point screw and test for gas soundness. Close the boiler gas service cock.

5.4 INITIAL LIGHTING - Refer to Fig. 5.1

1. Ensure that the gas and electrical supplies to the boiler are off.
2. Turn on the gas and electrical supplies to the boiler.
3. Ensure all external controls are calling for heat.
If the optional Clock is fitted, set the time and ensure the Clock is in an 'on' mode.
4. Set the central heating thermostat to maximum.
5. Set the selector switch to 'ON'. The boiler will now run. The external pump will start, the fan will start and the main gas valve solenoid will open allowing the main burner to light.

5.5 CHECK THE BURNER PRESSURES - Figs. 5.2 and 5.3

Turn the boiler off. Remove the two pressure test point screws at the top of the boiler and connect a differential pressure gauge to P1 and P2 as shown in Fig 5.2. Allow the boiler to run for 10 minutes and check the differential burner pressures.

1. Set the selector switch to 'ON'.
2. The burner will light at the ignition rate and will increase to the factory pre-set maximum output after approximately 4 minutes.

- Turn off the boiler. Disconnect the pressure gauge and tighten the test point screws. Test for gas soundness using suitable leak detection fluid.

Note: The burner pressure settings have been factory set and do not require adjusting. If incorrect, check that the inlet gas pressure is 20 mbar.

If the inlet gas pressure is not 20 mbar, either the pipework is too small or the gas supply to the house is insufficient, in which case contact your gas supplier. If the differential burner pressures are still incorrect contact Alpha.

Note: Refer to Technical Data, Section 2.1 for the required differential burner pressures.

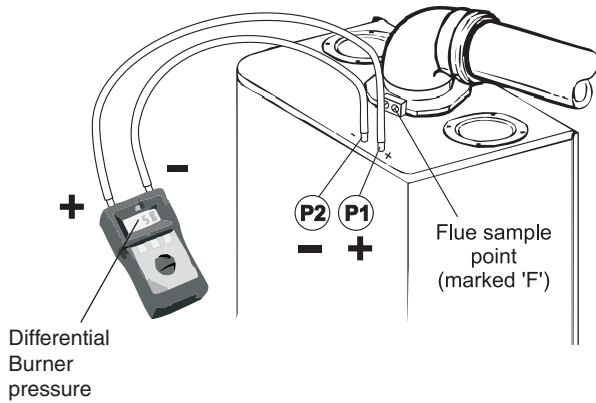

Fig. 5.2

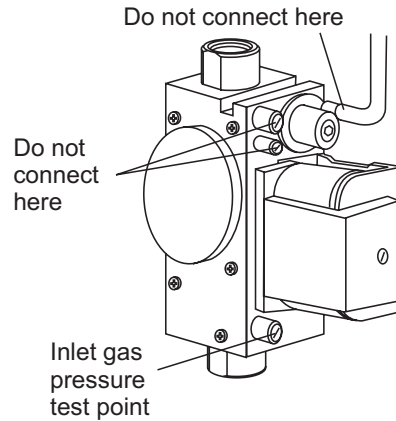

Fig. 5.3

5.6 FINAL COMMISSIONING

- Allow the heating system to heat up, then balance the system to achieve the necessary temperature difference across the heating flow and return pipes at the boiler.
- Turn off the boiler.

5.7 FINAL ASSEMBLY

- Raise the control panel and secure in position with the screws provided, locate the front casing panel in position and secure with the screw at the top of the panel.
- If the boiler is to be left in service with the User, set the controls, clock (if fitted, see Clock User's Operating manual) and room thermostat (if fitted) to the User's requirements.
- If the boiler is not to be handed over immediately, close the boiler gas service cock and switch off the electrical supply.
- If there is any possibility of the boiler being left during frost conditions, then the boiler and system should be drained (refer to Section 8.2). It is recommended that a label is attached to the boiler drawing attention to the fact that the system has been drained.
- Complete the details of the installation in the Benchmark Checklist on page 33.

5.8 USER INFORMATION

The User must be advised (and demonstrated if necessary) of the following important points:-

- How to light and turn off the boiler and how to operate the system controls.
- The importance of annual servicing of the boiler to ensure safe and efficient operation.
- That any servicing or replacement of parts must only be carried out by CORGI registered personnel.
- Ensure that the boiler controls and room thermostat (if fitted) are set to the User's requirements.
- Tell the User that if the electrical supply is on and the boiler has not operated for 24 hours for heating, the pump will automatically operate for 5 minutes.
- Explain to the User that an internal frost thermostat is fitted in the boiler, and that the electrical supply to the boiler must be left on for the thermostat to operate.
- Explain to the User that in certain weather conditions the terminal will emit a plume of steam, i.e. water vapour. This is safe and quite normal.
- Show the User the position of the condensate discharge pipe.
- Hand the User's instructions to the User.
- Complete the details of the installation in the Benchmark Checklist at the back of these instructions.
- Leave these Installation and Servicing instructions with the User for use on future calls.

6 BOILER OPERATION

6.1 CENTRAL HEATING MODE

The operating sequence of the boiler is controlled by the selector switch on the control panel.

Setting the selector switch to position (2) the boiler will operate to provide central heating.

When the selector is set to central heating, it will respond to a demand for heat in the following sequence:-

- a. The external pump will start, the fan will operate and the main burner will light.
- b. The output of the burner is automatically controlled to suit the system demand.
- c. When the temperature of the system water in the boiler reaches that set by the thermostat or the room thermostat is satisfied, the main burner is turned off and the fan stops after 50 seconds. The pump will continue to run to remove any residual heat from the boiler.

6.3 FROST THERMOSTAT

The boiler incorporates a built in frost thermostat which automatically turns on the boiler and pump if the water in the boiler falls below 8°C, providing the electrical supply is on and the selector switch is set to position (1) or position (2). The boiler will operate until the water temperature in the system reaches approximately 40°C.

6.4 PUMP

If the electrical supply is on and the boiler has not operated for 24 hours for heating or hot water, the external pump will operate automatically for five minutes every 24 hours.

6.5 INDICATOR NEONS

When neons A (red), B (red), C (yellow), D (green) are illuminated, the following conditions apply:-

Neon

- D** Illuminated continuously - Electricity supply to the boiler is on.
- C** Illuminated continuously - Burner is alight.
- A** Flashing on and off - Temperature sensor fault.
- B** Flashing on and off - Overheat thermostat has operated. Rotate selector switch to the reset position (3) to reset.
- B** Illuminated continuously - Burner has failed to light. Rotate selector switch to the reset position (3) and the ignition sequence will restart after a delay of about 30 seconds.
- A and B** Flashing on and off at the same time - Blocked flue or fan fault.
- A** Flashing and **B** Illuminated continuously - Pump fault or restricted flow.
- A** Illuminated continuously and **B** flashing - PCB or flame sensor fault.
- A and B** illuminated continuously - No flow or air present
- A, B and C** flashing on and off at the same time - Temperature sensor wiring or flow and return connections incorrect.

Note: Do not hold the selector switch in the reset position (3) for more than 2 to 3 seconds.

7 ROUTINE SERVICING

To ensure efficient operation of the boiler it is recommended that it is checked and serviced as necessary at regular intervals. The frequency of servicing will depend upon the particular installation conditions and usage, but in general once per year should be adequate.

It is the law that any service work must be carried out by a competent person, i.e. Gas Safe registered personnel.

Warning: Before servicing the boiler, isolate the electrical supply and close the boiler gas service cock. Allow the boiler to cool.

The data label is positioned on the underneath of the bottom casing.

Always test for gas soundness after servicing any gas carrying components.

Always carry out electrical system checks i.e. Earth Continuity, Resistance to Earth, Short Circuit and Polarity with a suitable meter after servicing.

General

Please Note: During routine servicing, and after any maintenance or change of part of the combustion circuit, the following must be checked:

1. The integrity of the flue system and the flue seals, as described in Section 4.6 and 4.7.
2. The integrity of the boiler combustion circuit and relevant seals.
3. The operational (working) gas inlet pressure at maximum rate, as described in Section 5.5.
4. The combustion performance, as described below.

Competence to carry out the check of combustion performance

Please Note: BS 6798:2009 Specification for installation and maintenance of gas-fired boilers of rated input not exceeding 70 kW net advises that:

1. The person carrying out a combustion measurement should have been assessed as competent in the use of a flue analyser and the interpretation of the results.
2. The flue gas analyser used should be one meeting the requirements of BS 7927 or BS-EN 50379-3 and be calibrated in accordance with the analyser manufacturers' requirements.
3. Competence can be demonstrated by satisfactory completion of the CPA1ACS assessment, which covers the use of electronic portable combustion gas analysers in accordance with BS 7967, Parts 1 to 4.

Combustion check

Connect the flue gas analyser to the flue gas sampling point as shown in Fig. 5.2.

Notes: 1. Prior to servicing, it is recommended that a flue gas analyser is used to measure the performance of the boiler (refer to Fig. 5.2 for the position of the flue sampling point). If the CO/CO₂ ratio measured is greater than 0.003 **or** when other checks and comments from the customer have indicated that there may be problems, cleaning of the heat exchanger will be necessary. All Sections 6.1, 6.2, 6.3 and 6.4 **must** be carried out. Repeat the flue gas analyser test after reassembling the boiler and check that the CO/CO₂ ratio is less than 0.003.

If the CO/CO₂ ratio reading is still above, then you must repeat Sections 7.1, 7.2, 7.3 and 7.4 until you obtain a ratio reading of below 0.003.

If the combustion reading is greater than the acceptable value AND the integrity of the complete flue system and combustion circuit seals have been verified and the inlet gas pressure (and gas rate) have been verified. Please call our Technical Helpline.

2. If the CO/CO₂ ratio measured is less than 0.003 and other checks and comments from the customer suggest there are no problems then only Section 7.1 and Section 7.2 paragraphs 1, 2 and 3 need to be carried out to allow a visual check of the components within the room sealed chamber.
3. If a flue gas analyser is not available, then all Sections 7.1, 7.2, 7.3 and 7.4 **must** be carried out.

7.1 IMPORTANT NOTES PRIOR TO SERVICING

1. Check the flue terminal outside and ensure it is not blocked.
2. Run the boiler and check the operation of its controls.
3. Refer to Fig. 2.3 for location of flue sampling point.
4. Ensure that all system connections and fittings are sound. Remake any joints and check the tightness of any fittings that may be leaking.
5. Check that the condensate trap drain pipe is connected and all joints are sound.
6. Record details of the service in the Service Record at the back of these instructions.

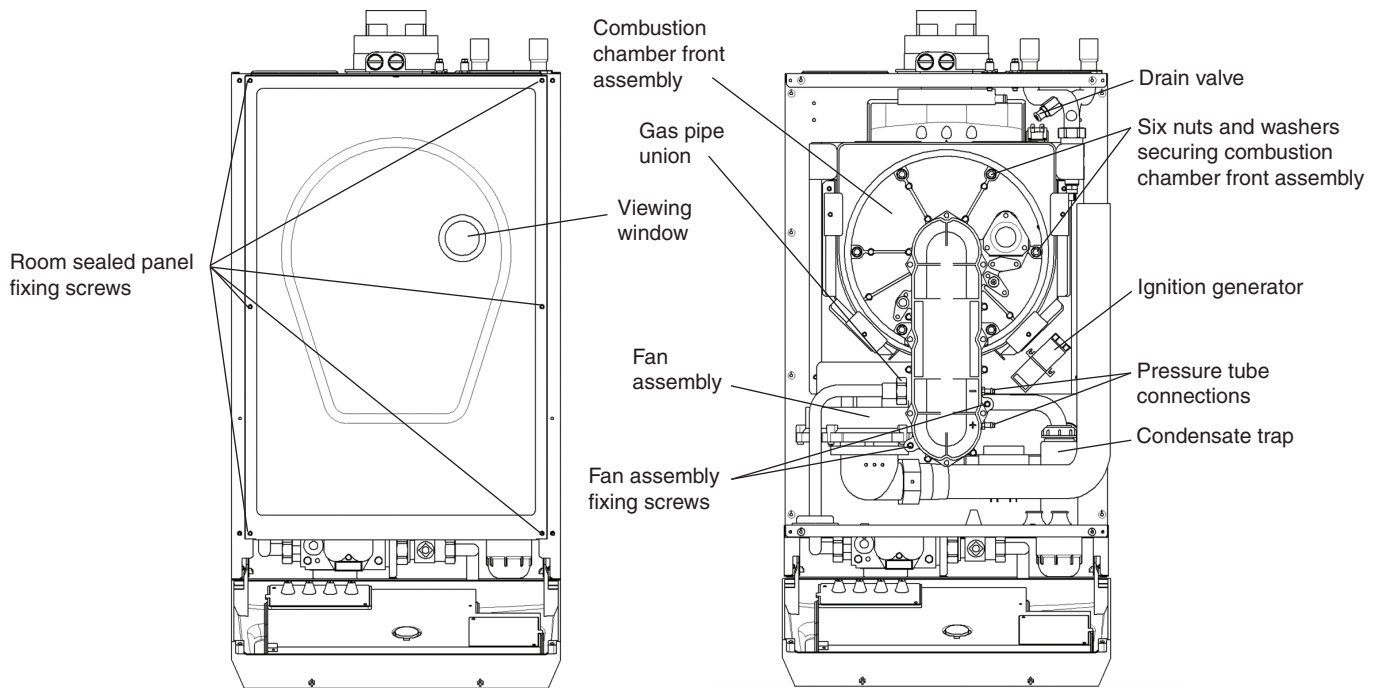

Fig. 7.1

7.2 PREPARE FOR SERVICING - Fig. 7.1

1. Ensure the electrical supply is isolated and the gas supply is off.
2. Remove the screw at the top centre of the front panel, then lift it up and remove the panel. Release the two screws securing the control panel and lower the panel.
3. Remove the six screws securing the room sealed chamber panel and remove the panel, taking care not to damage the seal.
4. Disconnect the gas supply pipe union.
5. Remove the two screws securing the fan assembly to the combustion chamber front.
6. Remove the two pressure tubes, noting their positions.
7. Disconnect the electrode lead from the ignition generator and the in-line connector to the flame sensing electrode.
8. Remove the six nuts and washers securing the combustion chamber front assembly and remove the assembly.

7.3 CLEANING THE BOILER

1. Remove any deposits from heat exchanger using a suitable soft brush. Do not use a brush with metallic bristles.
2. Check the condition of the combustion chamber insulation panels. Any damaged panels must be replaced. (Refer to Component Replacement, Section 8.17).
3. Check the condition of the burner injector on the combustion chamber front assembly, carefully clean it with a soft brush if necessary.
Do not use a brush with metallic bristles as this might damage the injector.
4. Remove any deposits from the heat exchanger coils. This can be done by suction or water sprayed onto the coils. Ensure all electrical components are protected from water. Any water used to clean the heat exchanger will drain to the condensate trap.
5. Unscrew and replace the injector if it appears damaged.
6. Remove the four screws securing the burner (see Fig. 7.2) and remove the burner. Clean the burner with a soft brush and check that the flame ports are clear. Blockages may be removed with a stiffer brush. Tap the burner, open end down, to remove any deposits from inside.
7. Check the condition of the electrodes.
9. Check the spark gap, positioning and height of the electrodes. See Fig. 7.2.
10. Unscrew the condensate trap drain cap, clean and remove any deposits from the trap.
Note: Before removing the cap, ensure that the water released from the trap can be contained to avoid spillage. The trap will contain no more than 200 cc of condensate water. Replace the drain cap.

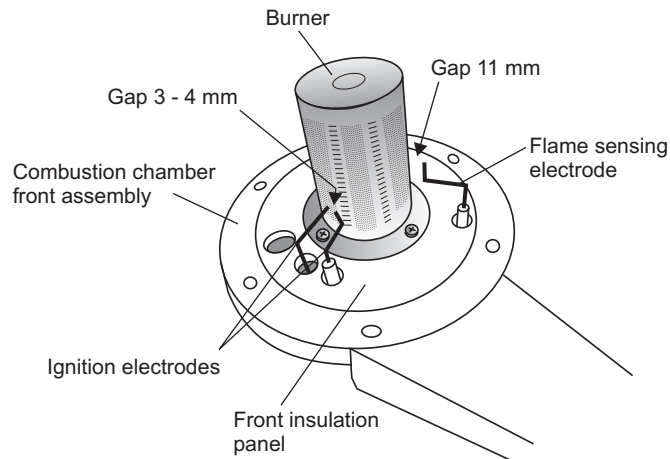

Fig. 7.2

7.4 RE-ASSEMBLE THE BOILER

1. Replace the burner, ensuring it is located correctly and secure it in position using the four screws previously removed.
Important: Before replacing the combustion chamber front assembly, pour at least 200 cc of water into the coils of the heat exchanger. This is to ensure the condensate trap is full of water before operating the boiler.
2. Replace the combustion chamber front assembly, ensuring it is correctly located.
3. Ensure the electrode lead is connected and the seal is in position in the bottom of the room sealed chamber.
4. Test the connections for gas soundness and re-commission, Sections 5.4 and 5.5.
5. Ensure that the room sealed chamber panel seal is intact and in position, replace the panel ensuring it has been located correctly and secure it in position with the screws previously removed.
6. Raise the control panel and secure in position with the two screws provided.
7. Replace the front case panel and secure in position.
8. Check the operation of the boiler. (Refer to Boiler Operation, Section 6).
9. Return all controls to their original settings.

To ensure correct and safe operation of the appliance, it is essential that any worn or failed components are replaced with only genuine Alpha spare parts. Use of non-genuine Alpha spares could invalidate your warranty and may pose a potential safety hazard.

8 COMPONENT REPLACEMENT

It is the law that any service work must be carried out by a competent person, i.e. Gas Safe registered personnel.

Warning: Before replacing any boiler components, isolate the electrical supply and close the boiler gas service cock. Allow the boiler to cool.

Always test for gas soundness after replacing any gas carrying components or disturbing any gas connections.

Always carry out electrical system checks i.e. Earth Continuity, Resistance to Earth, Short Circuit and Polarity with a suitable meter after servicing.

Check the operation of the boiler. (Refer to Boiler Operation, Section 6).

Ensure that all the controls are returned to their original settings.

The replacement of components in Sections 8.3 to 8.15 does not require draining of the boiler.

8.1 GENERAL ACCESS - Fig. 7.1

Isolate the electrical supply and close the boiler gas cock (see Fig. 4.4).

1. **If access is required behind the control panel** - Release the fixing screw located at the top of the case front panel and lift the panel upwards from its locating pins and then forwards from the boiler. Remove the two fixing screws that secure the control panel and lower the panel.
2. **To gain access to the control panel components** - Remove the five screws securing the rear cover and carefully raise the cover from the control panel. When replacing the cover, ensure no wires are trapped and all wiring is secured. Secure with screws previously removed - do not overtighten.
3. **To gain access behind the room sealed chamber panel** - Remove the six screws securing the room sealed chamber panel and remove the panel, taking care not to damage the seal.
Note: When replacing the panel, ensure the seal is intact and that the panel has been located correctly.

8.2 DRAINING THE BOILER - Refer to Figs. 2.3 or 7.1

1. Isolate the electricity supply and close the boiler gas service cock (see Fig. 4.4). Allow the boiler to cool.
2. Gain access as described in Section 8.1. Connect a hose to the drain valve located in the flow pipe just above the heat exchanger (see Fig. 7.1) and route it to a suitable container. Open the drain valve.
Note: Water will remain in the heat exchanger and care must be taken when removing it to prevent any electrical components from becoming wet.

8.3 ELECTRODES - See Fig. 7.2

Gain access behind the room sealed chamber panel as in Section 8.1.

1. **Ignition electrode and lead**
Disconnect the lead from the ignition generator, noting its position.
Remove the two screws securing the electrode to the front of the combustion chamber and carefully withdraw the electrode.
2. **Flame sensing electrode and lead**
Remove the grommet in the bottom of the chamber, disconnect the flame sensing electrode in-line connector and withdraw the lead.
Remove the two screws securing the electrode to the front of the combustion chamber and carefully withdraw the electrode.
3. **Ignition electrode**
Remove the two screws securing the electrode to the front of the combustion chamber and carefully withdraw the electrode.

Re-assemble in reverse order

8.4 MAIN BURNER - Fig. 7.2

1. Remove the burner assembly as described in Routine Servicing, Section 7.2.
2. Remove the four screws securing the burner to the combustion chamber front assembly.
3. Re-assemble with a new burner as described in Routine Servicing, Section 7.4.

8.5 BURNER INJECTOR - Fig. 7.1

1. Gain access behind the room sealed chamber panel as described in Section 8.1.
2. Undo the gas inlet pipe union to the combustion chamber front to gain access.
3. Unscrew the damaged injector and screw in a replacement.
4. Re-assemble in reverse order.

8.6 FAN - Fig. 8.1

1. Gain access behind the room sealed chamber panel as described in Section 8.1 and remove the combustion chamber front assembly as described in Section 7.2.
2. Remove the screw securing the air inlet tube and remove.
3. Disconnect the fan wiring and remove the fan.
4. Remove the inlet and outlet flanges from the fan, fit them to the new fan and re-assemble in reverse order.
Ensure that the pressure tubes are connected correctly.
5. Re-assemble and test the boiler as described in Routine Servicing, Section 7.4 paragraphs 5 to 9.

8.7 IGNITION GENERATOR - Fig. 8.1

1. Gain access behind the room sealed chamber panel as described in Section 8.1.
2. Disconnect all the wiring from the ignition generator.
3. Remove the two screws securing the generator and remove.
4. Secure the new generator in position and re-connect the wiring.
5. Re-assemble in reverse order.

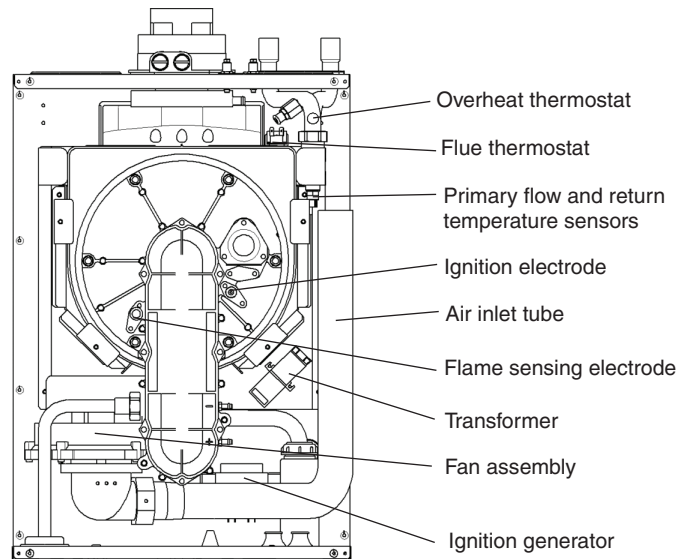

Fig. 8.1

8.8 TRANSFORMER - Fig. 8.1

1. Gain access behind the room sealed chamber panel as described in Section 8.1.
2. Remove the screw securing the air inlet tube and remove.
3. Remove the two screws securing the transformer and remove the transformer.
4. Disconnect all of the wiring from the transformer noting their position.
5. Fit the new transformer and re-assemble in reverse order.

8.9 OVERHEAT THERMOSTAT - Fig. 8.1

1. Gain access behind the room sealed chamber panel as described in Section 8.1.
2. Disconnect the wiring from the overheat thermostat.
3. Unscrew and remove the overheat thermostat from the heat exchanger.
4. Fit the new overheat thermostat taking care not to cross thread it and re-assemble in reverse order.

8.10 FLUE THERMOSTAT - Fig. 8.1

1. Gain access behind the room sealed chamber panel as described in Section 8.1.
2. Remove the two screws securing the thermostat retaining bracket and remove the thermostat from the top rear of the heat exchanger.
3. Disconnect the wiring.
4. Fit the new thermostat and re-assemble in reverse order.

8.11 GAS VALVE

1. The gas valve is located at the bottom of the boiler (see Fig. 4.4).
2. Disconnect the pressure tube from the gas valve.
3. Loosen the screw securing the electrical plug and remove the plug.
4. Disconnect the burner manifold union and the gas pipe union.
5. Remove the support bracket screws from beneath the boiler.
6. Lower the valve downwards and out of its location.
7. Unscrew the support bracket from the faulty valve and fit it to the new valve.
8. Fit the new assembly and re-assemble in reverse order.
9. Carry out a soundness test. Light the boiler and set the gas valve to the settings stated on the instruction sheet provided with the new valve.

8.12 VIEWING WINDOW - Fig. 7.1

1. Gain access behind the casing as in Section 8.1.
2. Remove the rubber window frame and remove the damaged glass.
3. Re-assemble in reverse order with a new glass. Ensure the rubber frame is located correctly in the front panel.

8.13 TERMINAL BLOCK FUSE - Refer to Fig. 4.13

The fuse is located in the boiler terminal block.

1. Gain access as described in Installation, Section 4.8.
2. Lift out the fuse holder and remove the fuse. Fit a fast blow 2 A fuse as a replacement, ensuring that the holder snaps into position.
3. Re-assemble in reverse order, ensuring the terminal block is located correctly on the plastic pins.

8.14 PCB - Fig. 8.2

1. Gain access behind the control panel as described in Section 8.1.
2. Disconnect all the wiring connectors from the PCB.
3. Remove the four fixing screws and carefully withdraw the board from the switch spindles.
4. Re-assemble in reverse order. Refer to the wiring diagram in Section 9.1 for connections.
5. Light the boiler and adjust the PCB as described in the instructions supplied with the replacement PCB.

8.15 CLOCK (if fitted) - Refer to Fig. 4.14

Note: For replacement only use an Alpha two channel clock. **Do not fit a single channel clock.**

1. Gain access behind the control panel as described in Section 8.1.
2. Remove the two screws securing the clock cover at the rear of the control panel.
3. Disconnect the wiring from the clock.
4. Remove the clock retaining screws and withdraw the clock from the control panel.
5. Fit the new clock, and connect the wires as follows:-
Brown wire to terminal 1, Blue wire to terminal 2, Black wire to terminal 3, Grey wire to terminal 4 and White wire to terminal 5, (or as per the instructions supplied with the clock).
6. Re-assemble in reverse order. Refer to the User's instructions and the boiler's control cover to set the clock.

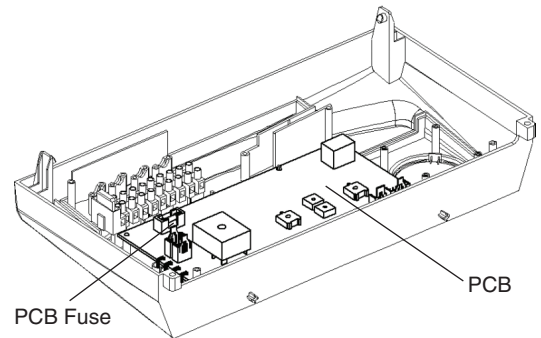

Fig. 8.2

8.16 PRIMARY HEAT EXCHANGER - See Fig. 8.3

1. Gain access behind the room sealed chamber panel as described in Section 8.1 and drain the boiler as described in Section 8.2.
2. Disconnect the gas inlet union from the combustion chamber manifold.
3. Remove the two screws and six nuts and washers securing the combustion chamber front burner assembly and remove.
4. Remove the overheat thermostat (Section 8.9), flue thermostat (Section 8.10) and unplug the primary temperature sensors (Section 8.18).
5. Disconnect the condensate drain union.
6. Undo the $\frac{3}{4}$ " flow and return unions.
7. Remove the four screws securing the heat exchanger retaining brackets and remove the brackets.
8. Slide the heat exchanger forwards from its mounting, being careful not to spill any water onto any electrical components
9. Empty the water from the heat exchanger, remove the two temperature sensors and transfer them to the new heat exchanger.
9. Fit the new heat exchanger to the boiler and re-assemble in reverse order, Refill the system. (Refer to Commissioning, Section 5.1).

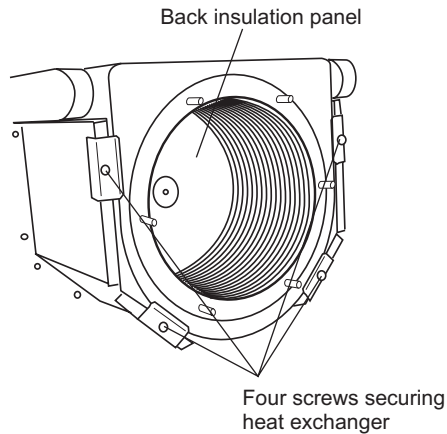

Fig. 8.3

8.17 COMBUSTION CHAMBER INSULATION

Gain access to the combustion chamber as described in Section 8.1.

Front insulation - see Fig. 7.2

1. Remove the electrodes from the combustion chamber front as described in Section 8.3.
2. Remove the four screws securing the burner.
3. Carefully remove the insulation.

Back insulation - see Fig. 8.3

1. Remove the combustion chamber front/burner assembly.
2. Remove the centre screw retaining the insulation.
3. Carefully remove the insulation, suction applied to the centre of the insulation will aid this.

Fit a new panel and re-assemble in reverse order.

Refill the system. (Refer to Commissioning, Section 5.1).

8.18 TEMPERATURE SENSORS - Refer to Fig. 8.1

Note that both sensors are the same.

1. Gain access as described in Section 8.1 and drain as described in Section 8.2.
2. Remove the screw securing the air inlet tube and remove.
3. The primary sensors are positioned on the right hand side of the heat exchanger (see Fig. 8.1), flow at the front and return at the rear. Disconnect the wiring and unscrew the sensor using a 13 mm A/F socket spanner, (access to the return sensor will be improved by removing the right side panel).
4. Re-assemble in reverse order with a new sensor and sealing washer.

Refill the system. (Refer to Commissioning, Section 5.1).

8.19 CONDENSATE TRAP - Fig. 4.4

1. Gain access behind the room sealed chamber as described in Section 8.1.
2. Disconnect the inlet and drain connection of the condensate trap.
3. Remove the fixing screw and lift the trap from its location.
4. Fill the new trap with water and fit it to the boiler and re-assemble in reverse order.

9 WIRING DIAGRAMS

9.1 ILLUSTRATED WIRING DIAGRAM

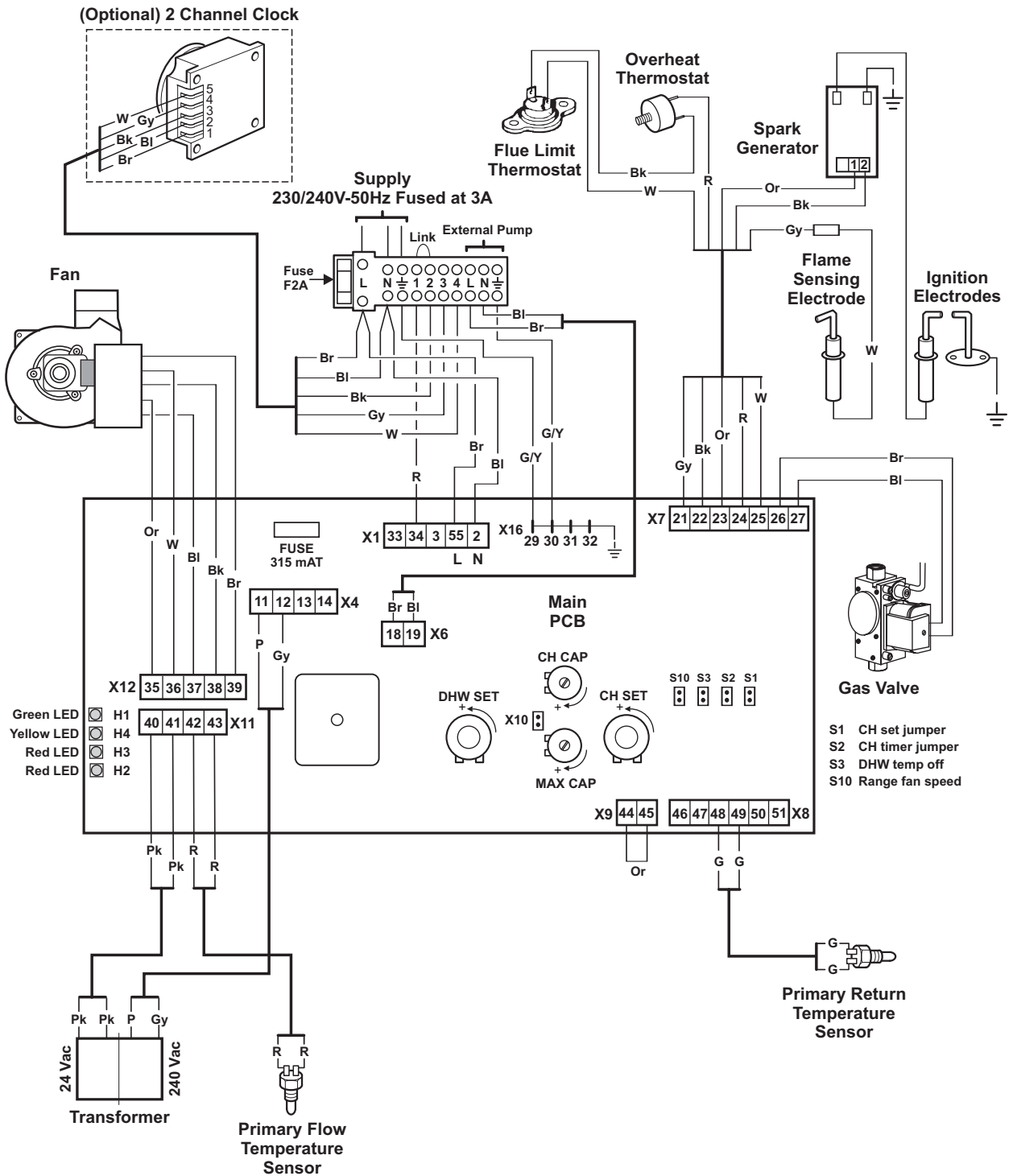

- Br - Brown
- Bk - Black
- Bl - Blue
- R - Red
- Or - Orange
- G - Green
- G/Y - Green/Yellow
- W - White
- Gy - Grey
- Pk - Pink
- P - Purple

NOTE: TO CONNECT EXTERNAL CONTROL REMOVE LINK FROM TERMINALS 1 & 2 AND CONNECT 230/240 V SWITCHED LIVE TO TERMINAL 1.

A FROST THERMOSTAT IS INCORPORATED WITHIN THE MAIN PCB

9.2 FUNCTIONAL FLOW WIRING DIAGRAM

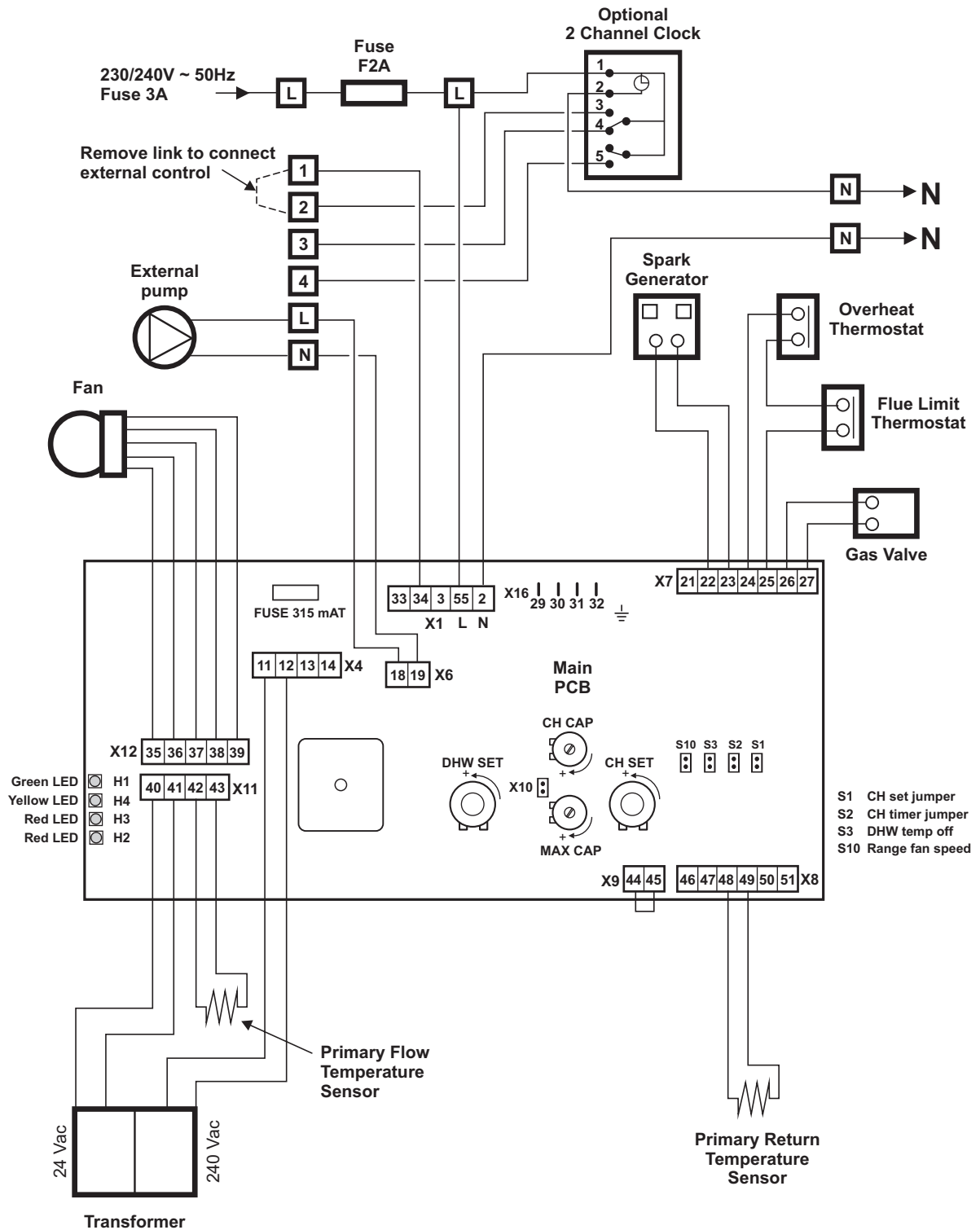

Note:  Main Terminal Block

TO CONNECT EXTERNAL CONTROL REMOVE LINK FROM TERMINALS 1 AND 2 AND CONNECT 230/240 V SWITCHED LIVE TO TERMINAL 1.

10 FAULT FINDING

10.1 CARRY OUT INITIAL FAULT FINDING CHECKS

- Check that gas, water and electrical supplies are available at the boiler.
 - i.e. Inlet gas pressure = 20 mbar
 - Electrical supply = 230/240 V ~ 50 Hz
 - CH water system pressurised to between 0.75 and 1.25 bar, if installed in a sealed central heating system.
- Carry out electrical system checks, i.e. Earth Continuity, Resistance to Earth, Short Circuit and Polarity with a suitable meter.

Note: These checks must be repeated after any servicing or fault finding.
- Ensure all external controls are calling for heat and check all external and internal fuses.
- Check that the gas and water pipework has been connected to the correct connections on the boiler and all valves are open.

However, before any servicing or replacement of parts ensure the gas and electrical supplies are isolated.

10.2 CENTRAL HEATING - Follow operational sequence

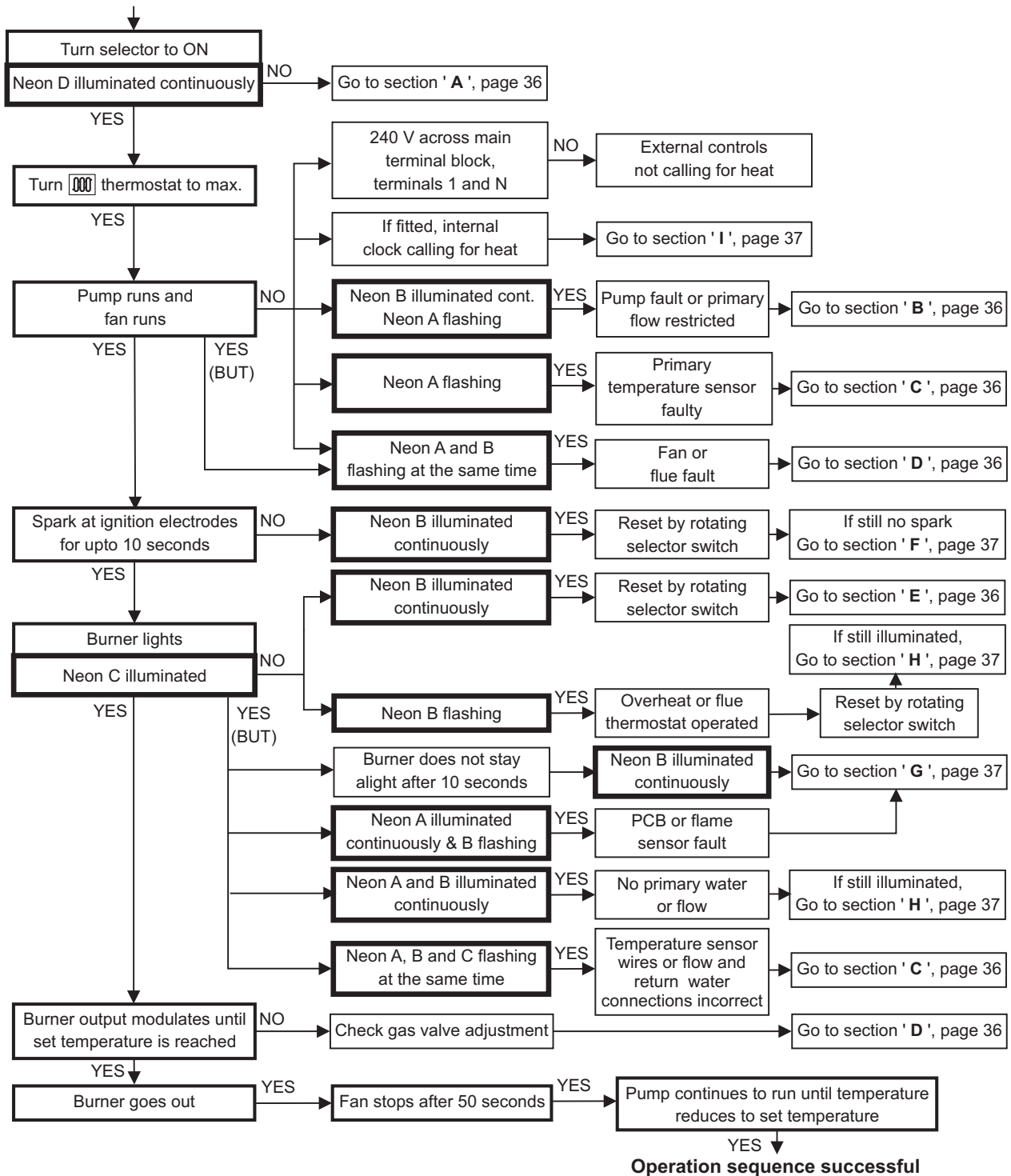

10.2 FAULT FINDING SOLUTIONS A to E

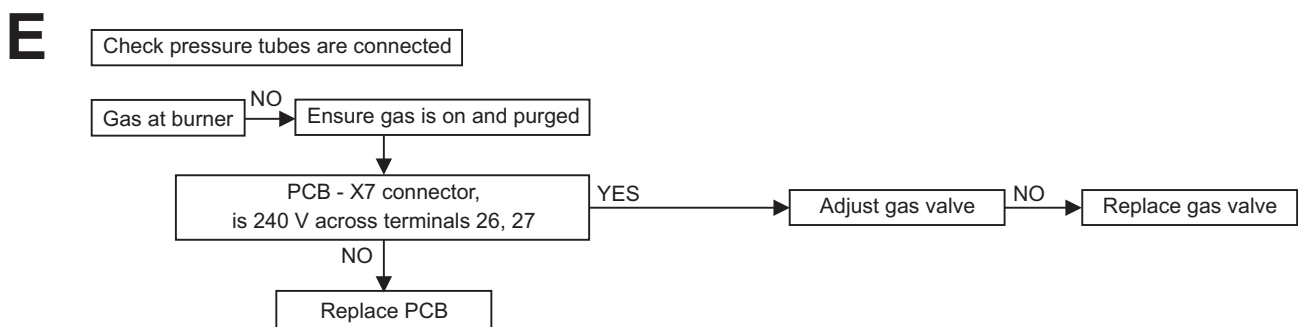
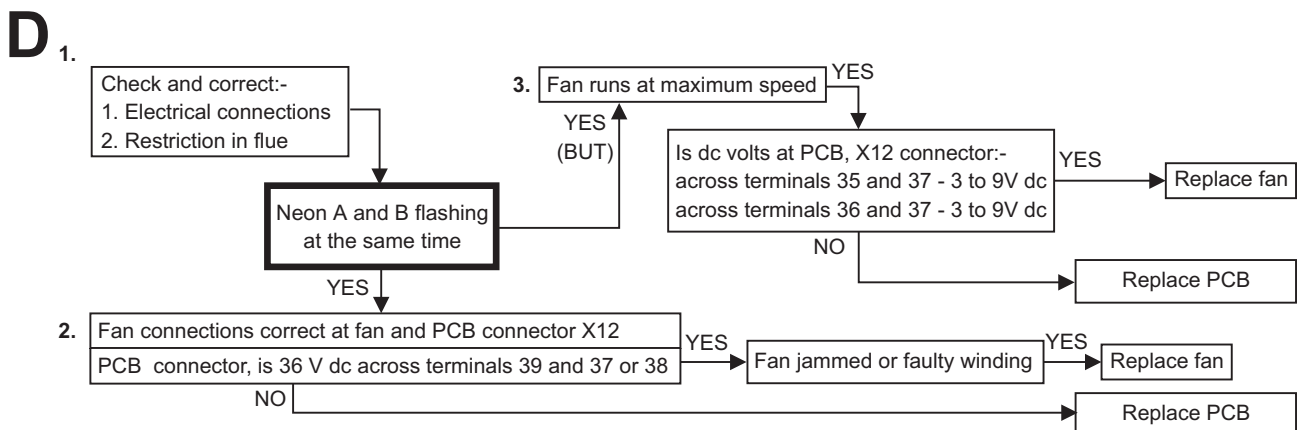
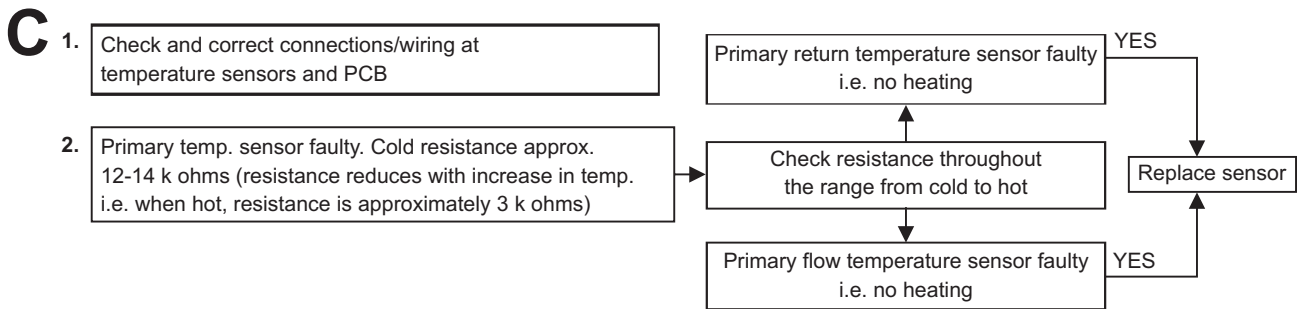
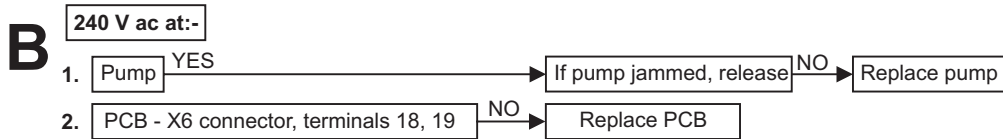
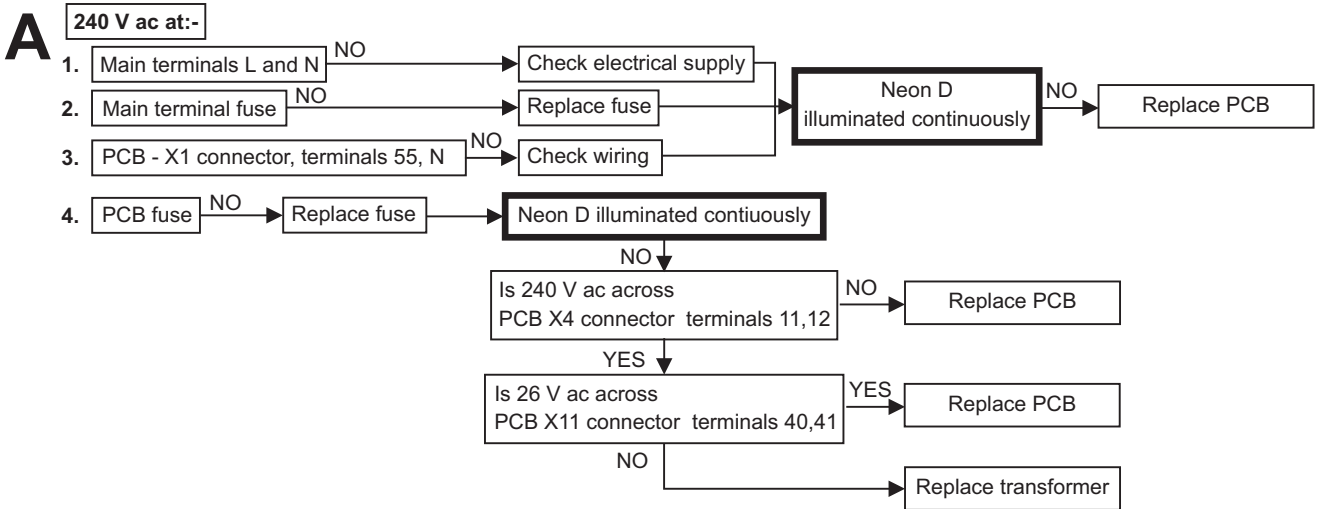

10.3 FAULT FINDING SOLUTIONS F to I

F

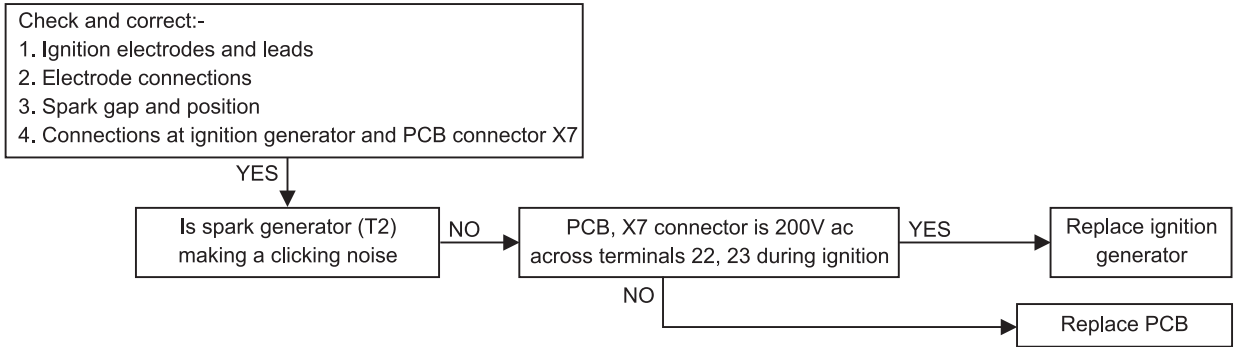

G

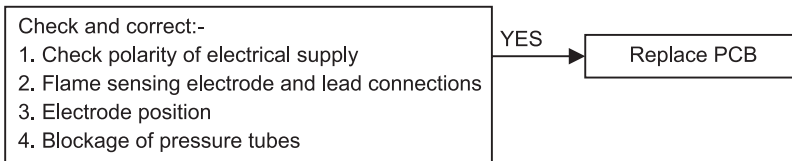

H

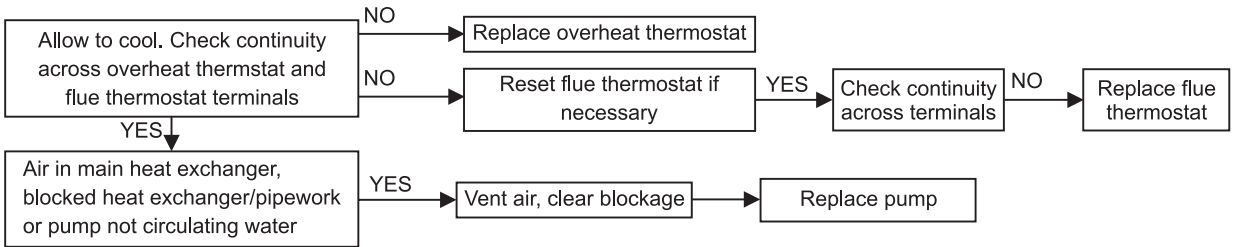

I

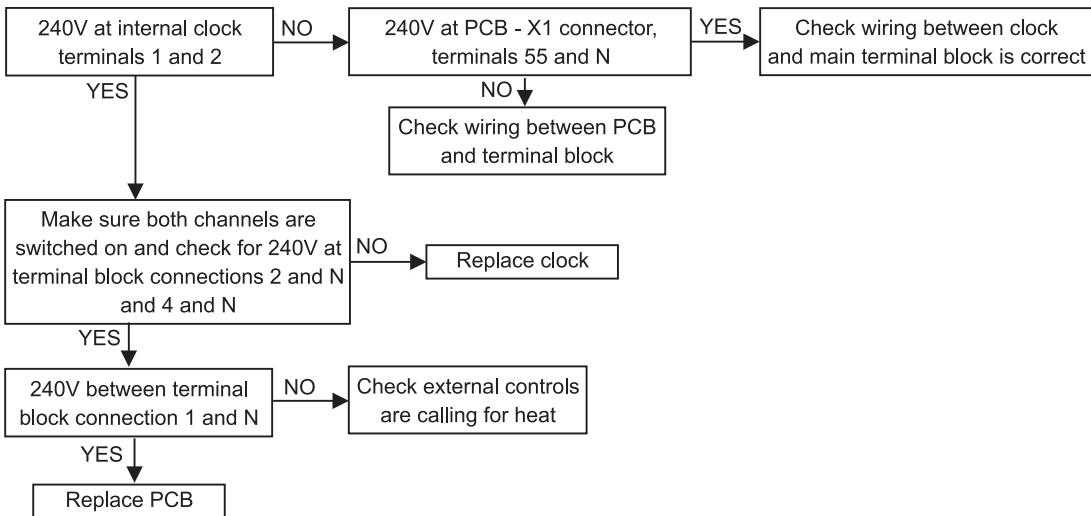

11 SHORT PARTS LIST

Reference	Description	Qty.	Alpha Pt. No.	British Gas GC No.
Fig. 7.2	Burner - CD 13R/18R	1	1.021877	H28-392
Fig. 7.2	Burner - CD 24R	1	1.013172	E94-407
Fig. 2.3	Main injector NG 5.1 mm - CD 13R/18R	1	1.022472	H28-393
Fig. 2.3	Main injector NG 5.25 mm - CD 24R	1	1.022709	
Fig. 2.3	Main injector LPG 4.0 mm - CD 13R/18R/24R			
Fig. 7.5	Primary heat exchanger - CD 13R/18R	1	1.021521	H28-394
Fig. 7.5	Primary heat exchanger - CD 24R	1	1.019725	
Fig. 5.3	Gas valve - Dungs	1	1.018808	H28-395
Fig. 7.1	Fan assembly	1	1.021206	H28-396
Fig. 7.4	PCB	1	1.027267	H28-397
Fig. 7.3	Flue thermostat (102°C)	1	1.023071	E94-413
Fig. 7.3	Ignition generator	1	1.018162	E94-414
Fig. 7.3	Transformer	1	1.012477	E94-415
Figs. 2.3 and 7.3	Temperature sensor	2	1.015970	E76-317
Fig. 20	Fuse F2 A	1	1.6098	E76-378
Fig. 7.4	PCB fuse F315 mA	1	1.013931	E96-571
Fig. 7.3	Overheat thermostat (90°C)	1	1.010952	H28-398
Fig. 7.3	Ignition electrode and lead	1	3.013626	E94-417
Fig. 7.2	Ignition electrode	1	1.016779	E94-418
Fig. 27.3 and Fig. 7.2	Flame sensing electrode and lead	1	1.019293	E96-572
Fig. 7.2	Combustion chamber insulation panel front	1	1.014732	E94-420
Fig. 4.4	Condensate trap	1	3.016875	

12 ENERGY CLASSIFICATION

12.1 TECHNICAL PARAMETERS FOR MIXED BOILERS (IN COMPLIANCE WITH REGULATION 813/2013)

The values in the following tables refer to the maximum heating output.

Model(s):				CD 13R				
Condensing boiler:				YES				
Low-temperature boiler:				NO				
B1 boiler:				NO				
Cogeneration space heater:				NO			Equipped with a supplementary heater:	NO
Combination heater:				NO				
Item	Symbol	Value	Unit	Item	Symbol	Value	Unit	
Rated heat output	P_n	12	kW	Seasonal space heating energy efficiency	η_s	90	%	
For boiler space heaters and boiler combination heaters: useful heat output				For boiler space heaters and boiler combination heaters: Useful efficiency				
At rated heat output and high temperature regime (*)	P_4	12.0	kW	At rated heat output and high temperature regime (*)	η_4	87.7	%	
At 30% of rated heat output and low temperature regime (**)	P_1	3.6	kW	At 30% of rated heat output and low temperature regime (**)	η_1	96.4	%	
Auxiliary electricity consumption				Other items				
At full load	eI_{max}	0.025	kW	Standby heat loss	P_{stby}	0.050	kW	
At part load	eI_{min}	0.021	kW	Ignition burner power consumption	P_{ign}	0.000	kW	
In standby mode	P_{SB}	0.007	kW	Emissions of nitrogen oxides	NO_x	31	mg / kWh	
For combination heaters:								
Declared load profile				Water heating energy efficiency				
				η_{WH}				
Daily electricity consumption				Daily fuel consumption				
Q_{elec}				Q_{fuel}				
Contact details								
Alpha Therm Ltd., Nepicar House, Wrotham Heath, Kent. TN15 7RS								
(*) High temperature regime means 60°C return temperature at heater inlet and 80°C feed temperature at heater outlet.								
(**) Low temperature means for condensing boilers 30°C, for low-temperature boilers 37°C and for other heaters 50°C return temperature.								

Model(s):				CD 18R				
Condensing boiler:				YES				
Low-temperature boiler:				NO				
B1 boiler:				NO				
Cogeneration space heater:				NO			Equipped with a supplementary heater:	NO
Combination heater:				NO				
Item	Symbol	Value	Unit	Item	Symbol	Value	Unit	
Rated heat output	P_n	18	kW	Seasonal space heating energy efficiency	η_s	90	%	
For boiler space heaters and boiler combination heaters: useful heat output				For boiler space heaters and boiler combination heaters: Useful efficiency				
At rated heat output and high temperature regime (*)	P_4	18.0	kW	At rated heat output and high temperature regime (*)	η_4	88.3	%	
At 30% of rated heat output and low temperature regime (**)	P_1	5.4	kW	At 30% of rated heat output and low temperature regime (**)	η_1	95.9	%	
Auxiliary electricity consumption				Other items				
At full load	eI_{max}	0.033	kW	Standby heat loss	P_{stby}	0.090	kW	
At part load	eI_{min}	0.022	kW	Ignition burner power consumption	P_{ign}	0.000	kW	
In standby mode	P_{SB}	0.007	kW	Emissions of nitrogen oxides	NO_x	33	mg / kWh	
For combination heaters:								
Declared load profile				Water heating energy efficiency				
				η_{WH}				
Daily electricity consumption				Daily fuel consumption				
Q_{elec}				Q_{fuel}				
Contact details								
Alpha Therm Ltd., Nepicar House, Wrotham Heath, Kent. TN15 7RS								
(*) High temperature regime means 60°C return temperature at heater inlet and 80°C feed temperature at heater outlet.								
(**) Low temperature means for condensing boilers 30°C, for low-temperature boilers 37°C and for other heaters 50°C return temperature.								

Model(s):				CD 24R					
Condensing boiler:				YES					
Low-temperature boiler:				NO					
B1 boiler:				NO					
Cogeneration space heater:				NO		Equipped with a supplementary heater:		NO	
Combination heater:				NO					
Item	Symbol	Value	Unit	Item	Symbol	Value	Unit		
Rated heat output	P_n	24	kW	Seasonal space heating energy efficiency	η_s	91	%		
For boiler space heaters and boiler combination heaters: useful heat output				For boiler space heaters and boiler combination heaters: Useful efficiency					
At rated heat output and high temperature regime (*)	P_4	23.5	kW	At rated heat output and high temperature regime (*)	η_4	88.2	%		
At 30% of rated heat output and low temperature regime (**)	P_1	7.1	kW	At 30% of rated heat output and low temperature regime (**)	η_1	96.4	%		
Auxiliary electricity consumption				Other items					
At full load	$e_{l_{max}}$	0.040	kW	Standby heat loss	P_{sby}	0.090	kW		
At part load	$e_{l_{min}}$	0.023	kW	Ignition burner power consumption	P_{ign}	0.000	kW		
In standby mode	P_{sb}	0.007	kW	Emissions of nitrogen oxides	NO_x	29	mg / kWh		
For combination heaters:									
Declared load profile				Water heating energy efficiency		η_{WH}	%		
Daily electricity consumption				Q_{elec}	kWh	Daily fuel consumption		Q_{fuel}	kWh
Contact details		Alpha Therm Ltd., Nepicar House, Wrotham Heath, Kent. TN15 7RS							
(*) High temperature regime means 60°C return temperature at heater inlet and 80°C feed temperature at heater outlet.									
(**) Low temperature means for condensing boilers 30°C, for low-temperature boilers 37°C and for other heaters 50°C return temperature.									

12.2 PRODUCT DATA SHEET (IN COMPLIANCE WITH REGULATION 811/2013)

CD 13R

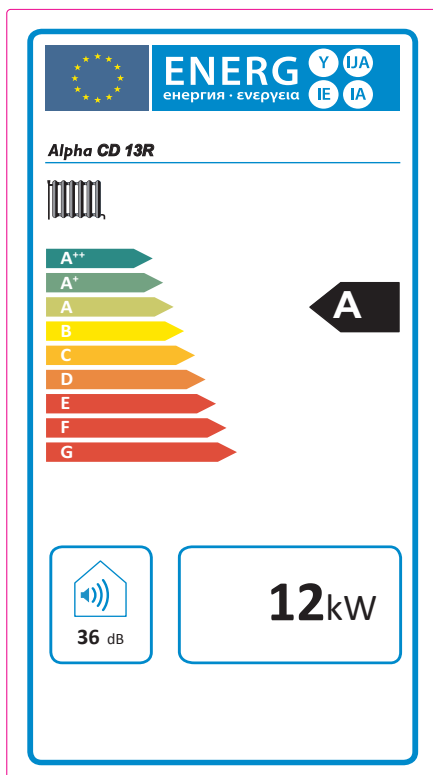

Parameter	Value
Yearly energy consumption for the heating function (QHE)	38.4 GJ
Yearly electricity consumption for the domestic hot water function (AEC)	-
Yearly fuel consumption for the domestic hot water function (AFC)	-
Seasonal room heating yield (η_s)	90 %
Domestic hot water production yield (η_{wh})	-

CD 18R

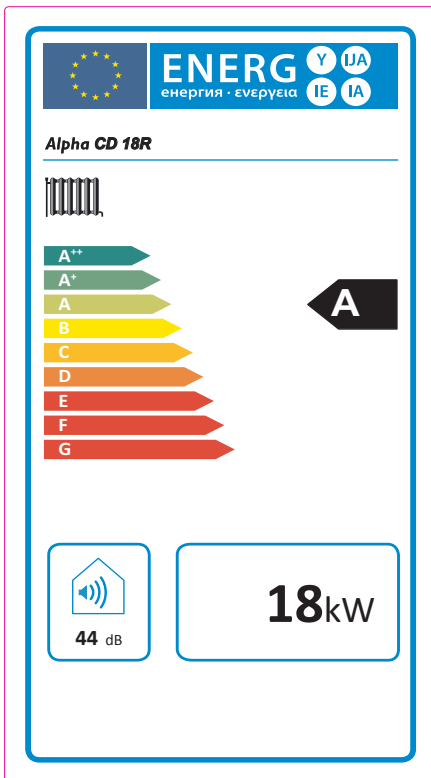

Parameter	Value
Yearly energy consumption for the heating function (QHE)	57.3 GJ
Yearly electricity consumption for the domestic hot water function (AEC)	-
Yearly fuel consumption for the domestic hot water function (AFC)	-
Seasonal room heating yield (η_s)	90 %
Domestic hot water production yield (η_{wh})	-

CD 24R

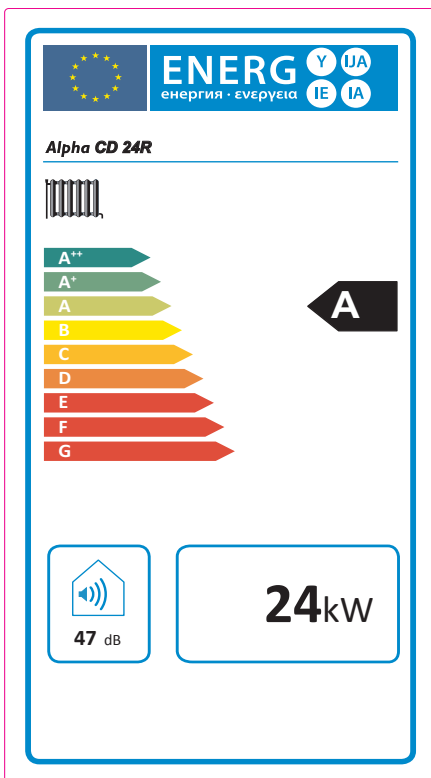

Parameter	Value
Yearly energy consumption for the heating function (QHE)	74.3 GJ
Yearly electricity consumption for the domestic hot water function (AEC)	-
Yearly fuel consumption for the domestic hot water function (AFC)	-
Seasonal room heating yield (η_s)	91 %
Domestic hot water production yield (η_{wh})	-

12.3 FACSIMILE FOR FILLING IN ROOM HEATING SYSTEM ASSEMBLY CHART

Seasonal space heating energy efficiency of boiler	① <input type="text"/> %																														
Temperature control From fiche of temperature control	② + <input type="text"/> %																														
Class I = 1 %, Class II = 2 %, Class III = 1.5 %, Class IV = 2 %, Class V = 3 %, Class VI = 4 %, Class VII = 3.5 %, Class VIII = 5 %																															
Supplementary boiler From fiche of boiler	③ ± <input type="text"/> %																														
Seasonal space heating energy efficiency (in %) $(\text{input} - 'I') \times 0,1 = \pm \text{input} \%$																															
<i>Solar contribution</i>																															
From fiche of solar device	④ + <input type="text"/> %																														
<table style="width: 100%; border-collapse: collapse;"> <tr> <td style="border: 1px solid black; padding: 2px;">Collector size (in m²)</td> <td style="border: 1px solid black; padding: 2px;">Tank volume (in m³)</td> <td style="border: 1px solid black; padding: 2px;">Collector efficiency (in %)</td> <td style="border: 1px solid black; padding: 2px;">Tank rating A* = 0.95, A = 0.91 B = 0.86, C = 0.83 D-G = 0.81</td> </tr> <tr> <td style="text-align: center;">↓</td> <td style="text-align: center;">↓</td> <td style="text-align: center;">↓</td> <td style="text-align: center;">↓</td> </tr> </table> $('III' \times \text{input} + 'IV' \times \text{input}) \times (0.9 \times \text{input} / 100) \times \text{input} = + \text{input} \%$		Collector size (in m ²)	Tank volume (in m ³)	Collector efficiency (in %)	Tank rating A* = 0.95, A = 0.91 B = 0.86, C = 0.83 D-G = 0.81	↓	↓	↓	↓																						
Collector size (in m ²)	Tank volume (in m ³)	Collector efficiency (in %)	Tank rating A* = 0.95, A = 0.91 B = 0.86, C = 0.83 D-G = 0.81																												
↓	↓	↓	↓																												
Supplementary heat pump From fiche of heat pump	⑤ + <input type="text"/> %																														
Seasonal space heating energy efficiency (in %) $(\text{input} - 'I') \times 'II' = + \text{input} \%$																															
<i>Solar contribution AND Supplementary heat pump</i>																															
Select smaller value	⑥ - <input type="text"/> %																														
$0.5 \times \text{input} \text{ O } 0.5 \times \text{input} = - \text{input} \%$																															
⑦ <input type="text"/> %																															
Seasonal space heating energy efficiency class of package																															
<table border="1" style="width: 100%; border-collapse: collapse;"> <tr> <td style="text-align: center;">□</td> <td style="text-align: center;">□</td> <td style="text-align: center;">□</td> <td style="text-align: center;">□</td> <td style="text-align: center;">□</td> <td style="text-align: center;">□</td> <td style="text-align: center;">□</td> <td style="text-align: center;">□</td> <td style="text-align: center;">□</td> <td style="text-align: center;">□</td> </tr> <tr> <td style="text-align: center;">G</td> <td style="text-align: center;">F</td> <td style="text-align: center;">E</td> <td style="text-align: center;">D</td> <td style="text-align: center;">C</td> <td style="text-align: center;">B</td> <td style="text-align: center;">A</td> <td style="text-align: center;">A⁺</td> <td style="text-align: center;">A⁺⁺</td> <td style="text-align: center;">A⁺⁺⁺</td> </tr> <tr> <td style="text-align: center;">< 30 %</td> <td style="text-align: center;">≥ 30 %</td> <td style="text-align: center;">≥ 34 %</td> <td style="text-align: center;">≥ 36 %</td> <td style="text-align: center;">≥ 75 %</td> <td style="text-align: center;">≥ 82 %</td> <td style="text-align: center;">≥ 90 %</td> <td style="text-align: center;">≥ 98 %</td> <td style="text-align: center;">≥ 125 %</td> <td style="text-align: center;">≥ 150 %</td> </tr> </table>		□	□	□	□	□	□	□	□	□	□	G	F	E	D	C	B	A	A⁺	A⁺⁺	A⁺⁺⁺	< 30 %	≥ 30 %	≥ 34 %	≥ 36 %	≥ 75 %	≥ 82 %	≥ 90 %	≥ 98 %	≥ 125 %	≥ 150 %
□	□	□	□	□	□	□	□	□	□																						
G	F	E	D	C	B	A	A⁺	A⁺⁺	A⁺⁺⁺																						
< 30 %	≥ 30 %	≥ 34 %	≥ 36 %	≥ 75 %	≥ 82 %	≥ 90 %	≥ 98 %	≥ 125 %	≥ 150 %																						
Boiler and supplementary heat pump installed with low temperature heat emitters at 35°C?																															
From fiche of heat pump	⑦ <input type="text"/> + (50 x 'II') = <input type="text"/> %																														
<i>The energy efficiency of the package of products provided for in this fiche may not correspond to its actual energy efficiency once installed in a building, as the efficiency is influenced by further factors such as heat loss in the distribution system and the dimensioning of the products in relation to building size and characteristics.</i>																															

12.4 ROOM HEATING SYSTEM ASSEMBLY CHART

Seasonal space heating energy efficiency of boiler 1 %

Temperature control
From fiche of temperature control 2 %

Class I = 1 %, Class II = 2 %,
 Class III = 1.5 %, Class IV = 2 %,
 Class V = 3 %, Class VI = 4 %,
 Class VII = 3.5 %, Class VIII = 5 %

Supplementary boiler
From fiche of boiler 3 %

Seasonal space heating energy efficiency (in %)

$$(\text{ } - \text{ }) \times 0,1 = \pm \text{ } \%$$

Solar contribution
From fiche of solar device 4 %

Collector size
(in m²)

Tank volume
(in m³)

Collector efficiency
(in %)

Tank rating
A* = 0.95, A = 0.91
B = 0.86, C = 0.83
D-G = 0.81

$$(\text{ } \times \text{ } + \text{ } \times \text{ }) \times (0,9 \times (\text{ } / 100) \times \text{ } = + \text{ } \%$$

Supplementary heat pump
From fiche of heat pump 5 %

Seasonal space heating energy efficiency (in %)

$$(\text{ } - \text{ }) \times \text{ } = + \text{ } \%$$

Solar contribution AND Supplementary heat pump
Select smaller value 6 %

$$0,5 \times \text{ } \text{ O } 0,5 \times \text{ } = - \text{ } \%$$

Seasonal space heating energy efficiency of package 7 %

Seasonal space heating energy efficiency class of package

□	□	□	□	□	□	□	□	□	□
G	F	E	D	C	B	A	A⁺	A⁺⁺	A⁺⁺⁺
< 30 %	≥ 30 %	≥ 34 %	≥ 36 %	≥ 75 %	≥ 82 %	≥ 90 %	≥ 98 %	≥ 125 %	≥ 150 %

Boiler and supplementary heat pump installed with low temperature heat emitters at 35°C?

From fiche of heat pump 7 + (50 x) = %

The energy efficiency of the package of products provided for in this fiche may not correspond to its actual energy efficiency once installed in a building, as the efficiency is influenced by further factors such as heat loss in the distribution system and the dimensioning of the products in relation to building size and characteristics.

12.5 PARAMETERS FOR FILLING IN ASSEMBLY CHART

Parameter	CD 13R	CD 18R	CD 24R
'I'	90	90	91
'II'	*	*	*
'III'	2.23	1.48	1.11
'IV'	0.87	0.58	0.44

* To be established by means of table 5 of Regulation 811/2013 in case of "assembly" including a heat pump to integrate the boiler. In this case the boiler must be considered as the main appliance of the assembly.



12.6 DOMESTIC HOT WATER PRODUCTION SYSTEM ASSEMBLY CHART

Water heating energy efficiency of combination heater 1 %

Declared load profile:

Solar contribution
From fiche of solar device

Auxiliary electricity
↓

(1.1 x - 10 %) x - - = 2 + %

Water heating energy efficiency of package under average climate 3 %

Water heating energy efficiency class of package under average climate

	<input type="checkbox"/>	<input type="checkbox"/>	<input type="checkbox"/>	<input type="checkbox"/>	<input type="checkbox"/>	<input type="checkbox"/>	<input type="checkbox"/>	<input type="checkbox"/>	<input type="checkbox"/>	<input type="checkbox"/>
	G	F	E	D	C	B	A	A⁺	A⁺⁺	A⁺⁺⁺
<input type="checkbox"/> M	< 27 %	≥ 27 %	≥ 30 %	≥ 33 %	≥ 36 %	≥ 39 %	≥ 65 %	≥ 100 %	≥ 130 %	≥ 163 %
<input type="checkbox"/> L	< 27 %	≥ 27 %	≥ 30 %	≥ 34 %	≥ 37 %	≥ 50 %	≥ 75 %	≥ 115 %	≥ 150 %	≥ 188 %
<input type="checkbox"/> XL	< 27 %	≥ 27 %	≥ 30 %	≥ 35 %	≥ 38 %	≥ 55 %	≥ 80 %	≥ 123 %	≥ 160 %	≥ 200 %
<input type="checkbox"/> XXL	< 28 %	≥ 28 %	≥ 32 %	≥ 36 %	≥ 40 %	≥ 60 %	≥ 85 %	≥ 131 %	≥ 170 %	≥ 213 %

Water heating energy efficiency under colder and warmer climate conditions

Colder: 3 - 0.2 x 2 = %

Warmer : 3 + 0.4 x 2 = %

The energy efficiency of the package of products provided for in this fiche may not correspond to its actual energy efficiency once installed in a building, as the efficiency is influenced by further factors such as heat loss in the distribution system and the dimensioning of the products in relation to building size and characteristics.

12.7 PARAMETERS FOR FILLING IN DHW PACKAGE ASSEMBLY CHART

Parameter	CD 13R	CD 18R	CD 24R
'I'	-	-	-
'II'	*	*	*
'III'	*	*	*

* To be determined according to Regulation 811/2014 and transient calculation methods as per Notice of the European Community no. 207/2014.



12.8 FACSIMILE FOR FILLING IN DOMESTIC HOT WATER PRODUCTION SYSTEM ASSEMBLY CHART

Water heating energy efficiency of combination heater

¹
 %

Declared load profile:

Solar contribution

From fiche of solar device

Auxiliary electricity

(1.1 x 'I' - 10 %) x 'II' - ²
 - 'I' = + %

Water heating energy efficiency of package under average climate

³
 %

Water heating energy efficiency class of package under average climate

	<input type="checkbox"/>	<input type="checkbox"/>	<input type="checkbox"/>	<input type="checkbox"/>	<input type="checkbox"/>	<input type="checkbox"/>	<input type="checkbox"/>	<input type="checkbox"/>	<input type="checkbox"/>	<input type="checkbox"/>
	G	F	E	D	C	B	A	A⁺	A⁺⁺	A⁺⁺⁺
<input type="checkbox"/> M	< 27 %	≥ 27 %	≥ 30 %	≥ 33 %	≥ 36 %	≥ 39 %	≥ 65 %	≥ 100 %	≥ 130 %	≥ 163 %
<input type="checkbox"/> L	< 27 %	≥ 27 %	≥ 30 %	≥ 34 %	≥ 37 %	≥ 50 %	≥ 75 %	≥ 115 %	≥ 150 %	≥ 188 %
<input type="checkbox"/> XL	< 27 %	≥ 27 %	≥ 30 %	≥ 35 %	≥ 38 %	≥ 55 %	≥ 80 %	≥ 123 %	≥ 160 %	≥ 200 %
<input type="checkbox"/> XXL	< 28 %	≥ 28 %	≥ 32 %	≥ 36 %	≥ 40 %	≥ 60 %	≥ 85 %	≥ 131 %	≥ 170 %	≥ 213 %

Water heating energy efficiency under colder and warmer climate conditions

Colder : ³
 - 0.2 x ²
 = %

Warmer : ³
 + 0.4 x ²
 = %

The energy efficiency of the package of products provided for in this fiche may not correspond to its actual energy efficiency once installed in a building, as the efficiency is influenced by further factors such as heat loss in the distribution system and the dimensioning of the products in relation to building size and characteristics.

GAS BOILER SYSTEM COMMISSIONING CHECKLIST

This Commissioning Checklist is to be completed in full by the competent person who commissioned the boiler as a means of demonstrating compliance with the appropriate Building Regulations and then handed to the customer to keep for future reference.

Failure to install and commission according to the manufacturer's instructions and complete this Benchmark Commissioning Checklist will invalidate the warranty. This does not affect the customer's statutory rights.

Customer name:	Telephone number:
Address:	
Boiler make and model:	
Boiler serial number:	
Commissioned by (PRINT NAME):	Gas Safe register number:
Company name:	Telephone number:
Company address:	
Commissioning date:	
To be completed by the customer on receipt of a Building Regulations Compliance Certificate*	
Building Regulations Notification Number (if applicable):	

CONTROLS (tick the appropriate boxes)			
Time and temperature control to heating	Room thermostat and programmer/timer	<input type="checkbox"/>	Programmable room thermostat
	Load/weather compensation	<input type="checkbox"/>	Optimum start control
Time and temperature control to hot water	Cylinder thermostat and programmer/timer	<input type="checkbox"/>	Combination Boiler
Heating zone valves	Fitted	<input type="checkbox"/>	Not required
Hot water zone valves	Fitted	<input type="checkbox"/>	Not required
Thermostatic radiator valves	Fitted	<input type="checkbox"/>	Not required
Automatic bypass to system	Fitted	<input type="checkbox"/>	Not required
Boiler interlock		<input type="checkbox"/>	Provided

ALL SYSTEMS			
The system has been flushed and cleaned in accordance with BS7593 and boiler manufacturer's instructions			Yes <input type="checkbox"/>
What system cleaner was used?			
What inhibitor was used?			Quantity <input type="text"/> litres
Has a primary water system filter been installed?			Yes <input type="checkbox"/> No <input type="checkbox"/>

CENTRAL HEATING MODE measure and record:			
Gas rate	m ³ /hr	OR	ft ³ /hr
Burner operating pressure (if applicable)	mbar	OR Gas inlet pressure	mbar
Central heating flow temperature	°C		
Central heating return temperature	°C		

COMBINATION BOILERS ONLY			
Is the installation in a hard water area (above 200ppm)?			Yes <input type="checkbox"/> No <input type="checkbox"/>
If yes, and if required by the manufacturer, has a water scale reducer been fitted?			Yes <input type="checkbox"/> No <input type="checkbox"/>
What type of scale reducer has been fitted?			

DOMESTIC HOT WATER MODE Measure and Record:			
Gas rate	m ³ /hr	OR	ft ³ /hr
Burner operating pressure (at maximum rate)	mbar	OR Gas inlet pressure at maximum rate	mbar
Cold water inlet temperature	°C		
Hot water has been checked at all outlets	Yes <input type="checkbox"/>	Temperature	°C
Water flow rate	l/min		

CONDENSING BOILERS ONLY	
The condensate drain has been installed in accordance with the manufacturer's instructions and/or BS5546/BS6798	
Yes <input type="checkbox"/>	

ALL INSTALLATIONS					
Record the following:	At max. rate:	CO	ppm	AND	CO/CO ₂ Ratio
	At min. rate: (where possible)	CO	ppm	AND	CO/CO ₂ Ratio
The heating and hot water system complies with the appropriate Building Regulations					Yes <input type="checkbox"/>
The boiler and associated products have been installed and commissioned in accordance with the manufacturer's instructions					Yes <input type="checkbox"/>
The operation of the boiler and system controls have been demonstrated to and understood by the customer					Yes <input type="checkbox"/>
The manufacturer's literature, including Benchmark Checklist and Service Record, has been explained and left with the customer					Yes <input type="checkbox"/>

Commissioning Engineer's Signature
Customer's Signature
(To confirm satisfactory demonstration and receipt of manufacturer's literature)

*All installations in England and Wales must be notified to Local Authority Building Control (LABC) either directly or through a Competent Persons Scheme. A Building Regulations Compliance Certificate will then be issued to the customer.



SERVICE RECORD

It is recommended that your heating system is serviced regularly and that the appropriate Service Interval Record is completed.

Service Provider

Before completing the appropriate Service Record below, please ensure you have carried out the service as described in the manufacturer's instructions. Always use the manufacturer's specified spare part when replacing controls.

SERVICE 01					Date:
Engineer name:					
Company name:					
Telephone No:					
Gas safe register No:					
Record:	At max. rate:	CO	ppm	AND	CO ₂ %
	At min. rate: (Where Possible)	CO	ppm	AND	CO ₂ %
Comments:					
Signature					

SERVICE 02					Date:
Engineer name:					
Company name:					
Telephone No:					
Gas safe register No:					
Record:	At max. rate:	CO	ppm	AND	CO ₂ %
	At min. rate: (Where Possible)	CO	ppm	AND	CO ₂ %
Comments:					
Signature					

SERVICE 03					Date:
Engineer name:					
Company name:					
Telephone No:					
Gas safe register No:					
Record:	At max. rate:	CO	ppm	AND	CO ₂ %
	At min. rate: (Where Possible)	CO	ppm	AND	CO ₂ %
Comments:					
Signature					

SERVICE 04					Date:
Engineer name:					
Company name:					
Telephone No:					
Gas safe register No:					
Record:	At max. rate:	CO	ppm	AND	CO ₂ %
	At min. rate: (Where Possible)	CO	ppm	AND	CO ₂ %
Comments:					
Signature					

SERVICE 05					Date:
Engineer name:					
Company name:					
Telephone No:					
Gas safe register No:					
Record:	At max. rate:	CO	ppm	AND	CO ₂ %
	At min. rate: (Where Possible)	CO	ppm	AND	CO ₂ %
Comments:					
Signature					

SERVICE 06					Date:
Engineer name:					
Company name:					
Telephone No:					
Gas safe register No:					
Record:	At max. rate:	CO	ppm	AND	CO ₂ %
	At min. rate: (Where Possible)	CO	ppm	AND	CO ₂ %
Comments:					
Signature					

SERVICE 07					Date:
Engineer name:					
Company name:					
Telephone No:					
Gas safe register No:					
Record:	At max. rate:	CO	ppm	AND	CO ₂ %
	At min. rate: (Where Possible)	CO	ppm	AND	CO ₂ %
Comments:					
Signature					

SERVICE 08					Date:
Engineer name:					
Company name:					
Telephone No:					
Gas safe register No:					
Record:	At max. rate:	CO	ppm	AND	CO ₂ %
	At min. rate: (Where Possible)	CO	ppm	AND	CO ₂ %
Comments:					
Signature					

SERVICE 09					Date:
Engineer name:					
Company name:					
Telephone No:					
Gas safe register No:					
Record:	At max. rate:	CO	ppm	AND	CO ₂ %
	At min. rate: (Where Possible)	CO	ppm	AND	CO ₂ %
Comments:					
Signature					

SERVICE 10					Date:
Engineer name:					
Company name:					
Telephone No:					
Gas safe register No:					
Record:	At max. rate:	CO	ppm	AND	CO ₂ %
	At min. rate: (Where Possible)	CO	ppm	AND	CO ₂ %
Comments:					
Signature					

*All installations in England and Wales must be notified to Local Authority Building Control (LABC) either directly or through a Competent Persons Scheme. A Building Regulations Compliance Certificate will then be issued to the customer.

6. GAS LEAK

If a fault or gas leak is suspected, turn off the gas supply. Do not touch any electrical switches, do not smoke and extinguish all naked flames. Contact your local Gas Region immediately.

7. ELECTRICAL SUPPLY

The boiler requires a 230/240 V ~ 50 Hz supply, fused at 3 A if a 13 A 3-pin plug is used or a 5 A fuse if any other type of plug is used.

To connect a plug:-

The colour of the wires in the mains lead of the boiler may not correspond with the coloured markings identifying the terminals in your plug. In this case proceed as follows:-

The wire coloured green and yellow must be connected to the terminal in the plug that is marked with the letter **E**, or by the earth symbol \equiv , or coloured green or green and yellow.

The blue wire must be connected to the terminal which is marked with either the letter **N** or coloured black.

The brown wire must be connected to the terminal which is marked with the letter **L** or coloured red.

THE APPLIANCE MUST BE EARTHED.

7 GAS SAFETY REGULATIONS

Current Gas Safety (Installation and Use) Regulations:-

It is the law that all gas appliances are installed and serviced by a competent person, i.e. Gas Safe registered personnel. Failure to install or service appliances correctly could lead to prosecution. It is in your interest and that of safety to ensure compliance with the law. The manufacturer's instructions must not be taken in any way as over-riding statutory obligations.

The Benchmark Checklist must be fully completed by the installer on installation of the boiler. The Benchmark Checklist is shown in back of the Installation and Servicing instructions. All Gas Safe registered installers carry a Gas Safe ID card and have a registration number. Both should be recorded in the Checklist. You can check your installer is Gas Safe registered by calling Gas Safe on 0800 408 5500.

8 FAULT FINDING FOR THE USER

If you experience a problem of no heating, try to solve the problem by following the simple checks below before calling out a service engineer.

If applicable, pull the controls panel cover forward and down to gain access to the controls.

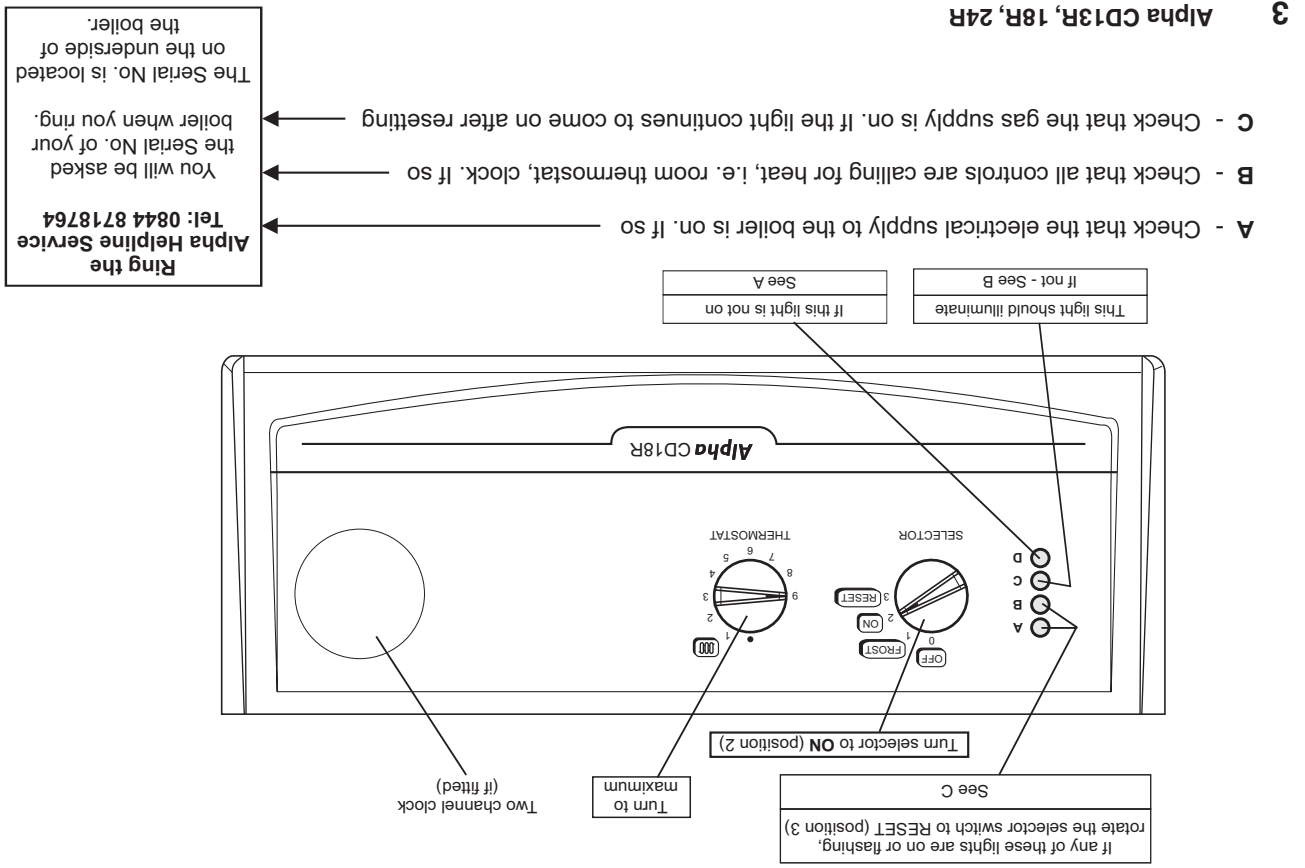

3 Alpha CD13R, 18R, 24R

4 LIGHTING INSTRUCTIONS

Refer to Fig. 1 for boiler controls.

1. Ensure the following:-

- a. Electrical supply to the boiler is off.
- b. All heating controls and thermostats are set to OFF or minimum position.
- c. The boiler gas isolation valve is in the open position (slot on the spindle in line with the valves i.e. ).
- d. The gas supply is on at the mains.
- e. The heating system is filled and vented.

2. Switch on the electrical supply to the boiler.

3. Set any room thermostats to maximum and ensure that any clock is in an 'on' position.

4. Set the selector switch to position (2) and turn the heating thermostat fully clockwise. The main burner will light and the boiler will provide central heating.

5. Set the boiler thermostat, clock, external controls i.e. room thermostat to your chosen settings and the boiler is ready to operate.

To turn the boiler off for short periods:- Set the selector switch to position (1).

Note: In this position the pump will automatically operate for 5 minutes in every 24 hours. If the water temperature falls below 8°C the built-in frost thermostat will operate the boiler automatically until the temperature of the water in the heating system has been raised.

To turn the boiler off for longer periods:- Switch off the electrical supply to the boiler. If required, all supplies i.e. gas, water and electricity may be turned off at the mains. If there is any possibility of the boiler being left during frost conditions,

then the boiler and system should be drained and a label attached to the boiler drawing attention that the system has been drained. If this is required, contact your Service Engineer.

5 BOILER OPERATION

The operating sequence of the boiler is controlled by the selector switch on the control panel.

Setting the selector switch to position (2) the boiler will operate to provide central heating.

When the selector is set to central heating, it will respond to a demand for heat in the following sequence:-

a. The external pump will start, the fan will operate and the main burner will light.

b. The output of the burner is automatically controlled to suit the system demand.

c. When the temperature of the system water in the boiler reaches that set by the thermostat or the room thermostat is satisfied, the main burner is turned off and the fan stops after 50 seconds. The pump will continue to run to remove any

residual heat from the boiler.

6 IMPORTANT NOTES

1. BOILER LOCATION

Always ensure the following clearances are available around the casing of the boiler:-

Top: 235 mm, Bottom: 250 mm, Each side: 5 mm, Front: 450 mm

Do not store any other articles in the cupboard containing the boiler and never place any clothing or combustible material on or near the boiler or flue pipe.

2. FLUE TERMINAL

The terminal on the outside wall must not be allowed to be obstructed. If it is damaged, in any way, turn the boiler off and contact your Service Engineer.

Note: The Alpha CD boilers are high efficiency condensing boilers and when operating vapour will be emitted from the terminal. This is safe and quite normal.

3. MAINS FAILURE

In the event of an electrical supply failure the boiler will not operate. When the supply is restored, the boiler will return to normal operation. Remember to reset the clock, if fitted, when the supply is restored.

4. CLEANING

Use only a damp cloth and mild detergent to clean the boiler outer casing. Do not use abrasive cleaners.

5. SERVICING

To maintain efficient and safe operation of your boiler, routine annual servicing is essential.

For advice on servicing contact:- The Alpha Helpline: 0844 871 8764.

Please read these instructions carefully before operating your boiler.

1 INTRODUCTION

The Alpha CD Regular range of high efficiency condensing boilers incorporate the latest technology in boiler design. With improved burner efficiency and reduced electrical consumption together with high quality and reliability. The boiler output will automatically adjust according to the requirements of the system.

2 USER CONTROLS

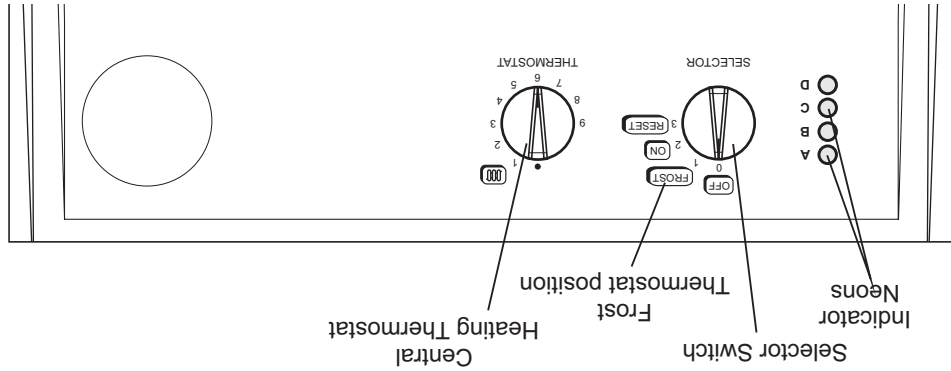

Fig. 1

3 BOILER CONTROLS

1. CENTRAL HEATING THERMOSTAT

This thermostat controls the temperature of the water leaving the boiler for the heating system. For maximum efficiency from the boiler the thermostat should be left at number 5 or 6 as shown in Fig. 1. If lower heating temperatures are required, turn the thermostat anti-clockwise. If higher heating temperatures are required, turn the thermostat clockwise.

2. SELECTOR SWITCH

This control is used to turn the boiler on and off or to 'reset' the ignition sequence or to set to frost thermostat only. The internal clock and frost thermostat will not operate when the switch is in the vertical position, i.e. 'Off' position (0).

3. INDICATOR NEONS

When neons A (red), B (red), C (yellow), D (green) are illuminated, the following conditions apply:-

Neon

D Illuminated continuously - Electricity supply to the boiler is on.

C Illuminated continuously - Burner is alight.

A Flashing on and off - Temperature sensor fault, contact your Service Engineer.

B Flashing on and off - Overheat thermostat has operated. Rotate selector switch to the reset position (3) to reset. If this continues to happen, contact your Service Engineer.

B Illuminated continuously - Burner has failed to light. Rotate selector switch to the reset position (3) and the ignition sequence will restart after a delay of about 30 seconds.

A and **B** Flashing on and off at the same time - Blocked flue or fan fault, contact your Service Engineer.

A Flashing and **B** Illuminated continuously - Pump fault or restricted flow.

A Illuminated continuously and **B** flashing - PCB or flame sensor fault.

A and **B** illuminated continuously - No flow or air present.

A, **B** and **C** flashing on and off at the same time - Contact your Service Engineer.

Note: Do not hold the selector switch in the reset position (3) for more than 2 to 3 seconds.

4. OVERHEAT THERMOSTAT

This thermostat automatically switches the boiler off in the unlikely event of the boiler overheating. When the thermostat operates, the red neon (B) flashes on and off. Rotate the selector switch to the reset position (3) and the boiler will relight. If this continually happens, contact your Service Engineer.

5. FROST THERMOSTAT

The boiler has a built-in frost thermostat, which automatically operates the boiler if the water temperature falls below 8°C, providing the electrical supply is on and the selector switch is set to position (1) 'Frost' or position (2) 'ON'.

User Instructions

Alpha CD 13R, 18R and 24R

Wall Mounted, Fan Assisted, Room Sealed, Gas Fired,
High Efficiency Condensing Regular Boiler Range

For Technical help or for Service call ...
ALPHA HELPLINE Tel: 0844 871 8764
website: www.alpha-innovation.co.uk

Alpha
HEATING INNOVATION

Nepicar House, London Road,
Wrotham Heath, Sevenoaks,
Kent TN15 7RS

Alpha CD 13R (NG)
Alpha CD 18R (NG)
Alpha CD 24R (NG)
Alpha CD 13R (LPG)
Alpha CD 18R (LPG)
Alpha CD 24R (LPG)
G.C. No. 41 532 05
G.C. No. 41 532 03
G.C. No. 41 532 04
G.C. No. 41 532 11
G.C. No. 41 532 09
G.C. No. 41 532 10

British Gas
Service Listed



Set for use with Natural Gas
Leave these instructions with the User

Part No. 1.038436 ST.001941/000
0615/D352

These instructions have been carefully prepared but we reserve the right
to alter the specification at any time in the interest of product improvement.
© Alpha Therm Limited 2015.

