

ATLAS

ISO 9001 : 2000
CERTIFIED COMPANY



CE

ISTRUZIONE PER L'USO L'INSTALLAZIONE E LA MANUTENZIONE
INSTRUCCIONES DE USO, INSTALACIÓN Y MANTENIMIENTO
KULLANMA, KURULUM VE BAKIM TALIMATLARI
INSTRUCTIONS FOR USE, INSTALLATION AND MAINTENANCE
INSTRUCTIONS D'UTILISATION, D'INSTALLATION ET D'ENTRETIEN
ΟΔΗΓΙΕΣ ΧΡΗΣΗΣ, ΕΓΚΑΤΑΣΤΑΣΗΣ ΚΑΙ ΣΥΝΤΗΡΗΣΗΣ
AANWIJZINGEN VOOR GEBRUIK, INSTALLATIE EN ONDERHOUD
РУКОВОДСТВО ПО ЭКСПЛУАТАЦИИ, МОНТАЖУ И ТЕХОБСЛУЖИВАНИЮ



EN

1. GENERAL INSTRUCTIONS

- Carefully read the instructions contained in this instruction booklet.
- After boiler installation, inform the user regarding its operation and give him this manual, which is an integral and essential part of the product and must be kept with care for future reference.
- Installation and maintenance must be carried out by professionally qualified personnel, according to current regulations and the manufacturer's instructions. Do not carry out any operation on the sealed control parts.
- Incorrect installation or inadequate maintenance can result in damage or injury. The Manufacturer declines any liability for damage due to errors in installation and use or failure to follow the instructions.
- Before carrying out any cleaning or maintenance operation, disconnect the unit from the power supply using the system switch and/or the special cut-off devices.
- In case of a fault and/or poor operation, deactivate the unit and do not attempt to repair it or directly intervene. Contact professionally qualified personnel. Repair/replacement of the products must only be carried out by professionally qualified using original spare parts. Failure to comply with the above could affect the safety of the unit.
- This unit must only be used for its intended purpose. Any other use is considered improper and therefore dangerous.
- The packing materials are potentially hazardous and must not be left within the reach of children.
- The images given in this manual are a simplified representation of the product. In this representation there may be slight and insignificant differences with respect to the product supplied.

2. OPERATING INSTRUCTIONS

2.1 Introduction

Dear Customer,

Thank you for choosing a **FERROLI** boiler featuring advanced design, cutting-edge technology, high reliability and quality construction. Please read this manual carefully since it provides important information on safe installation, use and maintenance.

ATLAS is a high-efficiency heat generator for the production of heating hot water, suitable for operation with blown oil or gas burners. The boiler shell consists of cast iron elements, assembled with steel stays and double cones, whose profile is specially designed with optimum division of the fins, offering high thermal efficiency and therefore high energy-saving.

2.2 Control panel

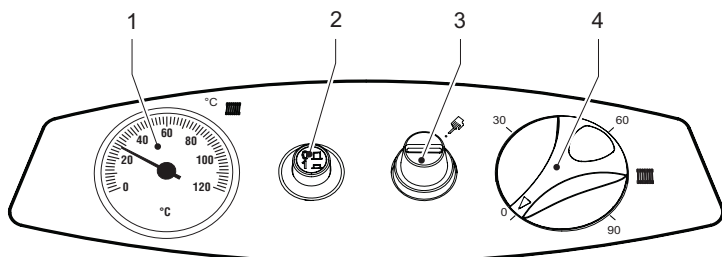

fig. 1 - Control panel for models ATLAS 32-78

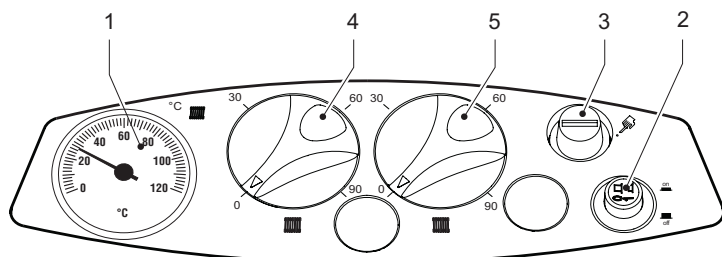

fig. 2 - Control panel for models ATLAS 95

Key

- 1 = Thermohydrometer
- 2 = On switch
- 3 = Manual-reset safety thermostat
- 4 = 1st stage temperature adjustment knob
- 5 = 2nd stage temperature adjustment knob

2.3 Turning on and off

Boiler lighting

Open the fuel shutoff valves.

Switch on the power to the unit.

Press button 2 of fig. 1 to feed the boiler and burner. Refer to the burner manual for operation.

Turning the boiler off

For brief shutdown periods just press button 2 of fig. 1 on the control panel, bringing it to position "0". For long shutdown periods, as well as operating button 2 also close the fuel shutoff valve. To avoid damage caused by freezing during long shutdowns in winter, add a suitable antifreeze to the system or completely drain the system.

2.4 Adjustments

Heating temperature setting

Set the required system temperature with the control thermostat 4 of fig. 1.

For the model **ATLAS 95**, with the control thermostat 5 then set the temperature of the 2nd stage to a temperature 10°C lower than that of the 1st stage.

IMPORTANT: The temperature setting of the 2nd stage must always be lower than that of the 1st stage.

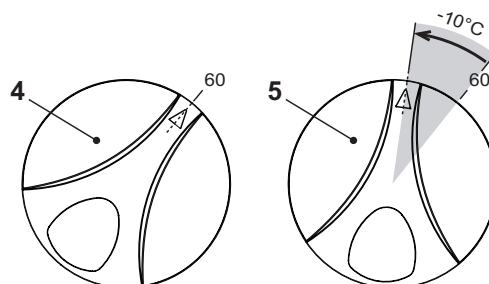

fig. 3 - Temperature adjustment for model ATLAS 95

Room temperature adjustment (with optional room thermostat)

Using the room thermostat, set the temperature desired in the rooms. If the room thermostat is not installed the boiler will keep the heating system at its setpoint temperature.

3. INSTALLATION

3.1 General Instructions

BOILER INSTALLATION MUST ONLY BE PERFORMED BY QUALIFIED PERSONNEL, IN ACCORDANCE WITH ALL THE INSTRUCTIONS GIVEN IN THIS TECHNICAL MANUAL, THE PROVISIONS OF CURRENT LAW, THE PRESCRIPTIONS OF NATIONAL AND LOCAL STANDARDS AND THE RULES OF PROPER WORKMANSHIP.

3.2 Place of installation

The boiler must be installed in a special room with ventilation openings towards the outside in conformity with current regulations. If there are several burners or extraction units that can work together in the same room, the ventilation openings must be sized for simultaneous operation of all the units. The place of installation must be free of flammable objects or materials, corrosive gases, volatile substances or dusts which, sucked by the burner fan, can obstruct the pipes inside the burner or the combustion head. The room must be dry and not exposed to rain, snow or frost.

If the unit is enclosed in a cabinet or mounted alongside, a space must be provided for removing the casing and for normal maintenance operations. In particular, after boiler installation with burner on the front door, make sure the front door can open freely without the burner striking walls or other obstacles.

3.3 Plumbing connections

The heating capacity of the unit must be previously established by calculating the building's heat requirement according to current regulations. The system must be provided with all the components for correct and regular operation. It is advisable to install shutoff valves between the boiler and heating system allowing the boiler to be isolated from the system if necessary.

The safety valve outlet must be connected to a funnel or collection pipe to prevent water spurting onto the floor in case of overpressure in the heating circuit. Otherwise, if the discharge valve cuts in and floods the room, the boiler manufacturer cannot be held liable.

Do not use the water system pipes to earth electrical appliances.

Before installation, carefully wash all the pipes of the system to remove any residuals or impurities that could affect proper operation of the unit.

Carry out the relevant connections according to the diagram in and the cap. 5 symbols given on the unit.

The unit is not supplied with an expansion tank; its connection must therefore be carried out by the installer. The pressure in the system, when cold, must be 1 bar.

Water system characteristics

In the presence of water harder than 25° Fr (1°F = 10ppm CaCO₃), use suitably treated water in order to avoid possible scaling in the boiler. Treatment must not reduce the hardness to values below 15°F (Decree 236/88 for uses of water intended for human consumption). Treatment of the water used is indispensable in case of very large systems or with frequent introduction of replenishing water in the system.

If water softeners are installed at the boiler cold water inlet, make sure not to reduce the water hardness too much, as this could cause early deterioration of the magnesium anode in the hot water tank.

Antifreeze system, antifreeze fluids, additives and inhibitors

The boiler is equipped with an antifreeze system that turns on the boiler in heating mode when the system delivery water temperature falls under 6°C. The device will not come on if the electricity and/or gas supply to the unit are cut off. If it becomes necessary, it is permissible to use antifreeze fluid, additives and inhibitors only if the manufacturer of these fluids or additives guarantees they are suitable for this use and cause no damage to the heat exchanger or other components and/or materials of the boiler unit and system. It is prohibited to use generic antifreeze fluid, additives or inhibitors that are not expressly suited for use in heating systems and compatible with the materials of the boiler unit and system.

3.4 Burner connection

An oil or gas burner, with blown air for pressured furnaces, can be used if its operation characteristics are suitable for the size of the boiler furnace and its overpressure. The choice of burner must be made beforehand, following the manufacturer's instructions, according to the work range, fuel consumption and pressures, as well as the length of the firebox. Install the burner in compliance with the Manufacturer's instructions.

3.5 Electrical connections

Connection to the electrical grid



The unit's electrical safety is only guaranteed when correctly connected to an efficient earthing system executed according to current safety standards. Have the efficiency and suitability of the earthing system checked by professionally qualified personnel. The manufacturer is not responsible for any damage caused by failure to earth the system. Also make sure that the electrical system is adequate for the maximum power absorbed by the unit, as specified on the boiler dataplate.

The boiler is prewired and provided with a Y-cable and plug for connection to the electricity line. The connections to the grid must be made with a permanent connection and equipped with a bipolar switch whose contacts have a minimum opening of at least 3 mm, interposing fuses of max. 3A between the boiler and the line. It is important to respect the polarities (LINE: brown wire / NEUTRAL: blue wire / EARTH: yellow-green wire) in making connections to the electrical line. During installation or when changing the power cable, the earth wire must be left 2 cm longer than the others.



The user must never change the unit's power cable. If the cable gets damaged, switch off the unit and have it changed solely by professionally qualified personnel. If changing the electric power cable, use solely "HAR H05 VV-F" 3x0.75 mm2 cable with a maximum outside diameter of 8 mm.

Accessing the electrical terminal block

Undo the two screws "A" located on the top part of the control panel and remove the cover "B".

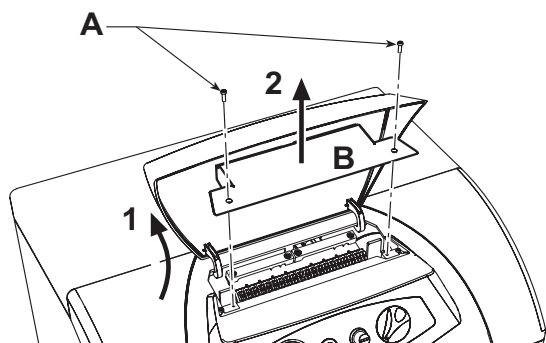

fig. 4 - Accessing the terminal block

3.6 Connection to the flue

The unit must be connected to a flue designed and built in compliance with current regulations. The pipe between the boiler and flue must be made from material suitable for the purpose, i.e. heat and corrosion resistant. Ensure the seal at the joints and insulate the entire pipe between boiler and flue, to prevent the formation of condensate.

4. SERVICE AND MAINTENANCE

All adjustment, conversion, start-up and maintenance operations described below must only be carried out by Qualified Personnel (meeting the professional technical requirements prescribed by current regulations) such as those of the Local After-Sales Technical Service.

FERROLI declines any liability for damage and/or injury caused by unqualified and unauthorised people tampering with the unit.

4.1 Adjustments

Burner adjustment

Boiler efficiency and correct operation depend above all on accurate burner adjustments. Carefully follow the Manufacturer's instructions. The two-stage burners must have the first stage adjusted to a power level not below the boiler's rated min. power. The power of the second stage must not be higher than the boiler's rated max. power.

4.2 Start-up



Checks to be made at first lighting and after all maintenance operations that involved disconnecting from the systems or an operation on safety devices or parts of the boiler:

Before lighting the boiler

- Open any on-off valves between the boiler and the systems.
- Check the seal of the fuel system.
- Check correct prefilling of the expansion tank.
- Fill the water system and make sure that all air contained in the boiler and the system has been vented, by opening the air valve on the boiler and any air valves on the system.
- Make sure there are no water leaks in the system, domestic hot water circuits, connections or boiler.
- Check correct connection of the electrical system and efficiency of the earthing system
- Make sure there are no flammable liquids or materials in the immediate vicinity of the boiler

Checks during operation

- Light the unit on as described in sec. 2.3.
- Make sure the fuel circuit and water systems are tight.
- Check the efficiency of the flue and air/fume ducts while the boiler is working.
- Make sure the water is circulating properly between the boiler and the systems.
- Check proper lighting of the boiler by doing several tests, turning it on and off with the room thermostat or remote control.
- Make sure the fuel consumption indicated on the meter matches that given in the technical data table on sec. 5.3.
- Make sure the fumebox and burner door are tight.
- Make sure the burner works properly. This check must be made with the special instruments, following the manufacturer's instructions.

4.3 Maintenance

Periodical check

To ensure correct operation of the unit over time, have qualified personnel carry out a yearly check, providing for the following:

- The control and safety devices must function correctly.
- The fume evacuation circuit must be perfectly efficient.
- Make sure there are no obstructions or dents in the fuel supply and return pipes.
- Clean the filter of the fuel suction line.
- Measure the correct fuel consumption
- Clean the combustion head in the fuel outlet zone, on the swirl disc.
- Leave the burner on at max. for about ten minutes, then analyse the combustion, checking:
 - Correct setting of the elements specified in this manual.
 - Temperatures of fumes at the flue
 - CO₂ percentage content
- The air/fume terminal and ducts must be free of obstructions and leaks
- The burner and exchanger must be clean and free of deposits. For cleaning do not use chemical products or wire brushes.
- The fuel and water systems must be tight.
- The water pressure in the system when cold must be approx. 1 bar; otherwise bring it to that value.
- The circulating pump must not be blocked.
- The expansion tank (not supplied) must be filled.



The boiler casing, control panel and aesthetic parts can be cleaned with a soft damp cloth, if necessary soaked in soapy water. Do not use any abrasive detergents and solvents.

Boiler cleaning

1. Disconnect the power supply to the boiler.
2. Remove the front top and bottom panel.
3. Open the door by undoing the knobs.
4. Clean the inside of the boiler and the entire path of exhaust fumes, using a tube brush or compressed air.
5. Then close the door, securing it with the knob.

To clean the burner, refer to the Manufacturer's instructions.

4.4 Troubleshooting

Fault

Two shutdown conditions resettable by the user can occur :

- A** Burner shutdown signalled by the special indicator. Refer to the burner manual.
- B** Cutting in of the safety thermostat, which occurs when the boiler temperature reaches a value beyond which a dangerous condition may be created. To restore operation, unscrew cap 3 of fig. 1 and press the reset button below.

If the problem persists, request the assistance of Qualified Personnel or the After-Sales Centre.

In case of a fault and/or poor operation, deactivate the unit, do not try to fix the problem or directly carry out any operation. Contact authorised and professionally qualified personnel.

5. TECHNICAL DATA AND CHARACTERISTICS

5.1 Dimensions, connections and main components

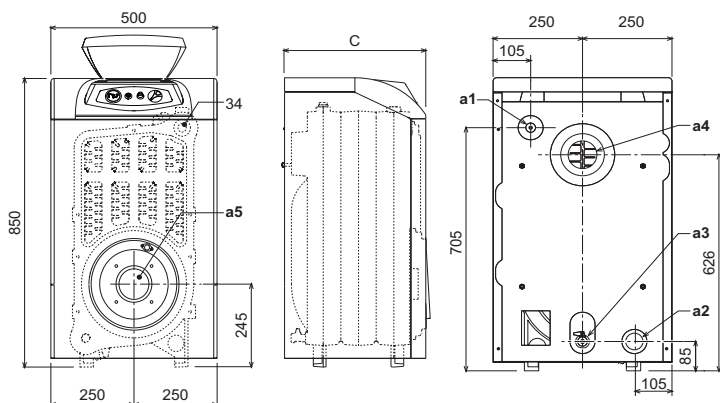

fig. 5 - Dimensions, connections and main components

Model	C mm	a4 Ø mm	a5 Ø mm
ATLAS 32	400	120+130	115
ATLAS 47	500	120+130	115
ATLAS 62	600	120+130	115
ATLAS 78	700	120+130	115
ATLAS 95	800	120+130	115

- a1 System delivery - 1" 1/2"
- a2 System return - 1" 1/2"
- a3 Heating system drain - 1/2"
- a4 Flue connection
- a5 Burner connection
- 34 Safety and heating temperature bulb

5.2 Pressure loss

Pressure loss water side

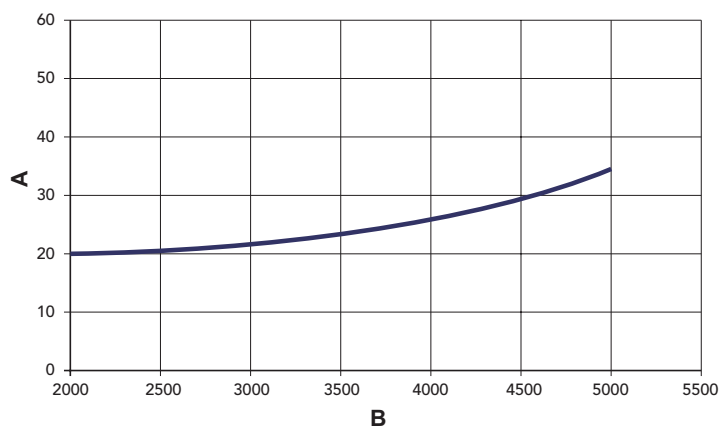

fig. 6 - Pressure loss

- A mbar
- B Flowrate l/h

5.3 Technical data table

Model		ATLAS 32	ATLAS 47	ATLAS 62	ATLAS 78	ATLAS 95	
Number of elements	no.	3	4	5	6	7	
Max. heating capacity	kW	34.9	51.6	67.7	85.6	103	(Q)
Min. heating capacity	kW	17.0	34.3	45.8	59.0	70.8	(Q)
Max. heat output in heating	kW	32	47	62	78	95	(P)
Min. heat output in heating	kW	16	32	43	55	66	(P)
Efficiency Pmax (80-60°C)	%	91.7	91.1	91.5	91.1	92	
Efficiency 30%	%	94.3	93.5	94.0	93.5	94.0	
Efficiency class Directive 92/42 EEC		★ ★					
Max. working pressure in heating	bar	6	6	6	6	6	(PMS)
Min. working pressure in heating	bar	0.8	0.8	0.8	0.8	0.8	
Max. heating temperature	°C	95	95	95	95	95	(tmax)
Heating water content	litres	18	23	28	33	38	
Protection rating	IP	X0D	X0D	X0D	X0D	X0D	
Power supply voltage	V/Hz	230/50	230/50	230/50	230/50	230/50	
Empty weight	kg	127	166	205	244	283	
Combustion chamber length	mm	350	450	550	650	750	
Combustion chamber diameter	mm	300	300	300	300	300	
Pressure loss flue side	mbar	0.27	0.3	0.45	0.4	0.63	

5.4 Wiring diagram

Main wiring diagram ATLAS 32-78

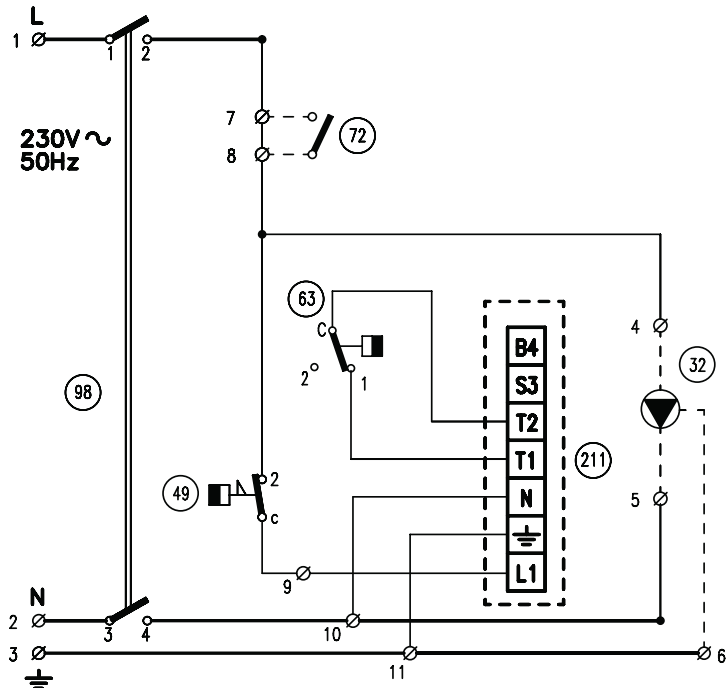

fig. 7 - Main wiring diagram ATLAS 32-78

Key fig. 7 and fig. 8

- 32 Heating circulating pump (not supplied)
- 49 Safety thermostat
- 72 Room thermostat (not supplied)
- 63 Boiler control thermostat
- 98 Switch
- 211 Burner connector (not supplied)

Electrical connection diagram ATLAS 32-78

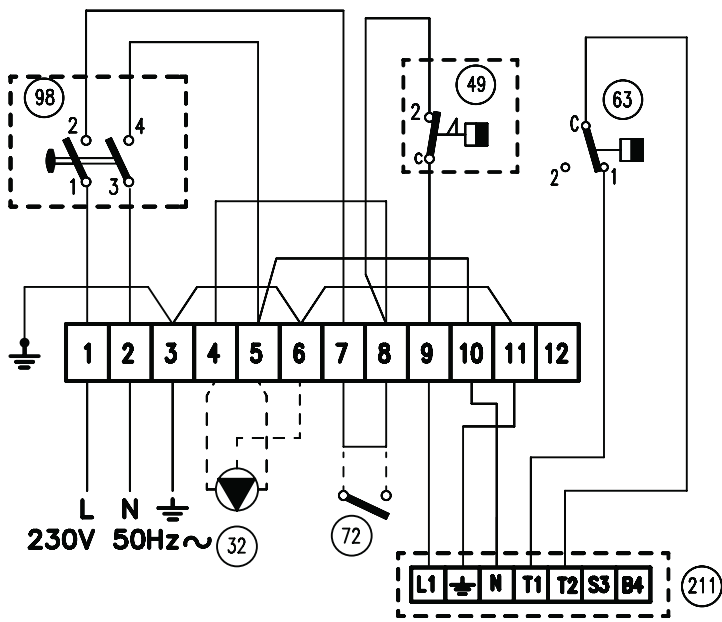

fig. 8 - Electrical connection diagram ATLAS 32-78

Main wiring diagram ATLAS 95

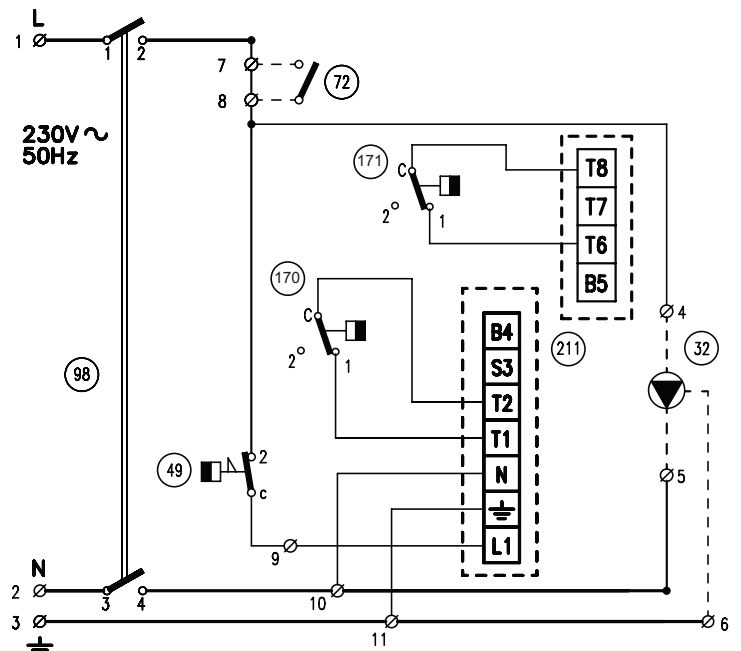

fig. 9 - Main wiring diagram ATLAS 95

Key fig. 9 and fig. 10

- 32 Heating circulating pump (not supplied)
- 49 Safety thermostat
- 72 Room thermostat (not supplied)
- 98 Switch
- 170 1st Stage boiler control thermostat
- 171 2nd Stage boiler control thermostat
- 211 Burner connector (not supplied)

Electrical connection diagram ATLAS 95

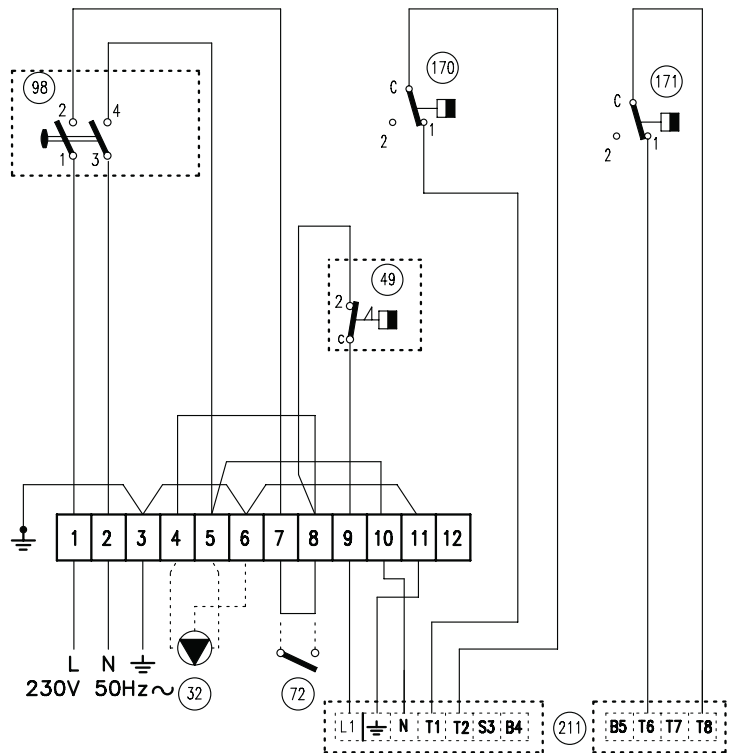

fig. 10 - Electrical connection diagram ATLAS 95

IT

Dichiarazione di conformità

Il costruttore: FERROLI S.p.A.

Indirizzo: Via Ritonda 78/a 37047 San Bonifacio VR

dichiara che questo apparecchio è conforme alle seguenti direttive CEE:

- Direttiva Apparecchi a Gas 90/396
- Direttiva Rendimenti 92/42
- Direttiva Bassa Tensione 73/23 (modificata dalla 93/68)
- Direttiva Compatibilità Elettromagnetica 89/336 (modificata dalla 93/68)

Presidente e Legale rappresentante

Cav. del Lavoro

Dante Feroli

**CE****ES**

Declaración de conformidad

El fabricante: FERROLI S.p.A.

Dirección: Via Ritonda 78/a 37047 San Bonifacio (Verona)

declara que este equipo satisface las siguientes directivas CEE:

- Directiva de Aparatos de Gas 90/396
- Directiva de Rendimientos 92/42
- Directiva de Baja Tensión 73/23 (modificada por la 93/68)
- Directiva de Compatibilidad Electromagnética 89/336 (modificada por la 93/68)

Presidente y representante legal

Caballero del Trabajo

Dante Feroli

**CE****TR**

Uygunluk beyanı

İmalatçı: FERROLI S.p.A.

Adres: Via Ritonda 78/a 37047 San Bonifacio VR

bu cihazın; aşağıda yer alan AET(EEC) yönergelerine uygunluk içinde olduğunu beyan etmektedir:

- 90/396 Gazla çalıştırılan üniteler için Yönetmelik
- 92/42 Randıman/Verimlilik Yönetmeliği
- Yönerge 73/23, Düşük Voltaj (93/68 nolu direktifle değişikliğe uğratıldı)
- 89/336 Elektromanyetik Uygunluk Yönetmeliği (93/68 ile değişiklik yapılmıştır)

Baskan ve yasal temsilci

İş. Dep.

Dante Feroli

**CE****EN**

Declaration of conformity

Manufacturer: FERROLI S.p.A.

Address: Via Ritonda 78/a 37047 San Bonifacio VR Italy

declares that this unit complies with the following EU directives:

- Gas Appliance Directive 90/396
- Efficiency Directive 92/42
- Low Voltage Directive 73/23 (amended by 93/68)
- Electromagnetic Compatibility Directive 89/336 (amended by 93/68)

President and Legal Representative

Cav. del Lavoro

Dante Feroli

**CE**

FR

Déclaration de conformité

Le constructeur : FERROLI S.p.A.

Adresse: Via Ritonda 78/a 37047 San Bonifacio VR

déclare que cet appareil est conforme aux directives CEE ci-dessous:

- Directives appareils à gaz 90/396
- Directive rendements 92/42
- Directive basse tension 73/23 (modifiée 93/68)
- Directive Compatibilité Electromagnétique 89/336 (modifiée 93/68)

Président et fondé de pouvoirs

Cav. du travail

Dante Ferrolì



CE

EL

Δήλωση συμμόρφωσης

Ο κατασκευαστής: FERROLI S.p.A.

Διεύθυνση: Via Ritonda 78/a 37047 San Bonifacio VR

δηλώνει ότι η παρούσα συσκευή συμμορφούται με τις ακόλουθές των οδηγιές ΕΟΚ:

- Οδηγία συσκευών στο αερίου 90/396
- Οδηγία αποδόσεων 92/42
- Οδηγία χαμηλής Τάσης 73/23 (τροποποιηθείσα από την 93/68)
- Οδηγία Ηλεκτρομαγνητικής Συμβατότητας 89/336 (τροποποιηθείσα από την 93/68)

Presidente e Legale rappresentante

Ο Πρόεδρος και νόμιμος εκπρόσωπος

Dante Ferrolì



NL

Conformiteitsverklaring

De fabrikant: FERROLI S.p.A.

Adres: Via Ritonda 78/a 37047 San Bonifacio VR

verklaart dat dit apparaat conform is aan de volgende EEG richtlijnen:

- Richtlijn Gastoestellen 90/396/EEG
- Richtlijn Rendementseisen 92/42/EEG
- Laagspanningsrichtlijn 73/23/EEG (gewijzigd door 93/68)
- Richtlijn Elektromagnetische compatibiliteit 89/336/EEG (gewijzigd door 93/68)

Voorzitter Raad van Bestuur en wettelijk vertegenwoordiger

Onderscheiden voor verdiensten op economisch gebied

Dante Ferrolì



CE

RU

Декларация соответствия

Изготовитель: FERROLI S.p.A.,

адрес: Via Ritonda 78/a 37047 San Bonifacio VR,

заявляет, что настоящее изделие соответствует следующим директивам CEE:

- Директива по газовым приборам 90/396
- Директива по К.П.Д. 92/42
- Директива по низкому напряжению 73/23 (с изменениями, внесенными директивой 93/68)
- Директива по электромагнитной совместимости 89/336 (с изменениями, внесенными директивой 93/68).

Президент и уполномоченный представитель

Кавалере дель лаворо (почетный титул, присуждаемый государством за заслуги в руководстве промышленностью)

Dante Ferrolì



CE

The logo features the word "ferroli" in a bold, lowercase, sans-serif font. A grey, curved graphic element arches over the top of the letters "e" and "r".

ferroli

FERROLI S.p.A.
Via Ritonda 78/a
37047 San Bonifacio - Verona - ITALY
www.ferroli.it