



Murelle

Ⓒ GB installation and servicing instructions

CONTENTS

1 TECHNICAL FEATURES AND DIMENSIONS

1.1	DESCRIPTION OF BOILER	1
1.2	DIMENSIONS	
1.3	TECHNICAL FEATURES	2
1.4	FUNCTIONAL DIAGRAM	3
1.5	INTERNAL VIEW	4
1.6	SYSTEM AVAILABLE HEAD	5

2 GENERAL REQUIREMENTS FOR INSTALLATION

2.1	BOILER ROOM	6
2.2	VENTILATION OF BOILER ROOM FOR "MURELLE" BOILERS	
2.3	CONNECTING UP SYSTEM	
2.4	WALL-MOUNTING PLATE	
2.5	CONNECTING UP "MURELLE" FLUE	7
2.6	"MURELLE BF" COAXIAL AIR INLET-FLUE OUTLET ASSEMBLY	8
2.7	"MURELLE BF" SEPARATE AIR INLET-FLUE OUTLET PIPES	10
2.8	CHARACTERISTICS OF FEEDWATER	13
2.9	WATER FAILURE SAFETY DEVICE	
2.10	SYSTEM FILLING	
2.11	"MURELLE 20 TX CE IONO" BOILER SUPPLY	14
2.12	ELECTRICAL CONNECTION	15
2.13	ELECTRONIC BOARD	19
2.14	TEMPERATURE SENSORS	20
2.15	ELECTRONIC IGNITION	
2.16	INTERRUPTION OF THE THERMOCOUPLE	21
2.17	SMOKE SAFETY DEVICE	
2.18	SMOKE PRESSURE SWITCH	
2.19	DISASSEMBLY OF OUTER CASING	22

3 USE AND MAINTENANCE

3.1	PRELIMINARY CHECKS ON IGNITION	23
3.2	DISASSEMBLY OF EXPANSION VESSEL	
3.3	GAS VALVE	24
3.4	GAS VALVE ADJUSTMENT	
3.5	ADJUSTMENT OF HEAT OUTPUT FOR HEATING	26
3.6	PILOT BURNER ADJUSTMENT	
3.7	CONVERSION TO DIFFERENT GAS	
3.8	FILTER ON GAS PIPE	27
3.9	CLEANING AND MAINTENANCE	
3.10	FAULT FINDING	28

1 Technical features and dimensions

1.1 DESCRIPTION OF BOILER

“MURELLE - MURELLE BF” boilers are gas-fired thermal appliances for central heating and D.H.W. production. They are equipped with all safety and control devices required by the law and their technical and operating features meet the requirements of the specifications on the safety and use of combustible gas. In addition, they are designed and built in accordance with the European Directives EN 297 - EN 483.

These appliances can be fired by natural gas (methane) and butane gas (G30) or propane gas (G31). This booklet provides instructions for the following boiler models:

- “MURELLE 20 R CE IONO” with electronic ignition and modulation (central heating only);
- “MURELLE 20 CE” with electronic modulation;

- “MURELLE 20 TX CE IONO” with electronic ignition and modulation, forced draught;
- “MURELLE 20 CE IONO - 25 CE IONO” with electronic ignition and modulation;
- “MURELLE 20 BFR CE IONO” with electronic ignition and modulation (central heating only), forced-draught sealed-room;
- “MURELLE 20 BF CE” with electronic modulation, forced-draught sealed-room;
- “MURELLE 20 BF CE IONO - 25 BF CE IONO” with electronic ignition and modulation, forced-draught sealed-room.

The instructions given in this manual are provided for the installer to ensure proper installation and perfect operation of the appliance.

1.2 DIMENSIONS

1.2.1 “MURELLE” version

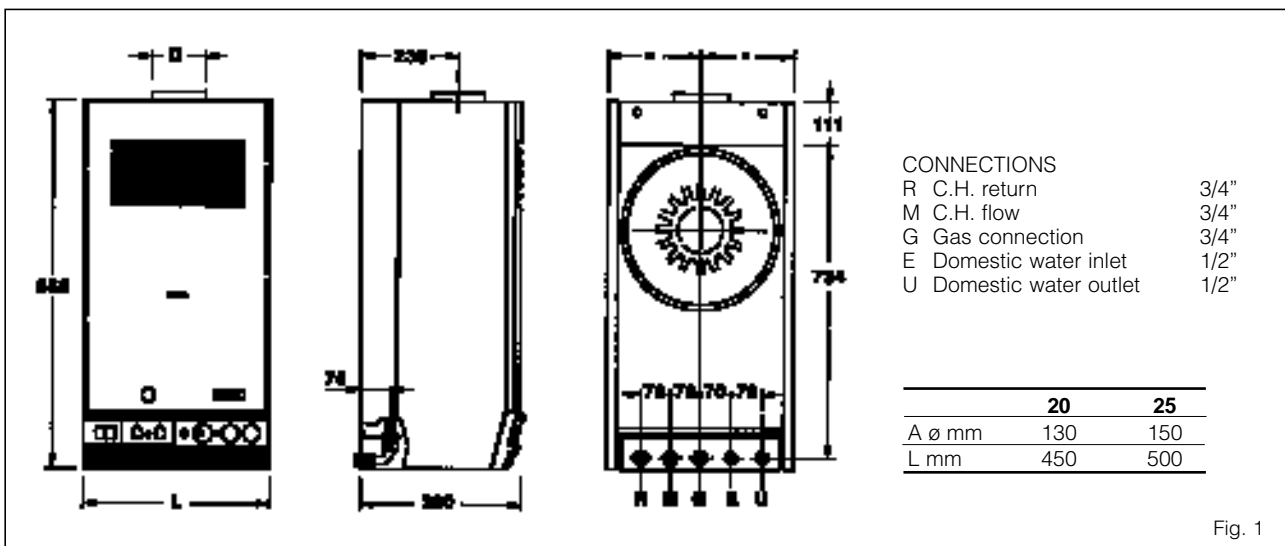

1.2.1 “MURELLE BF” version

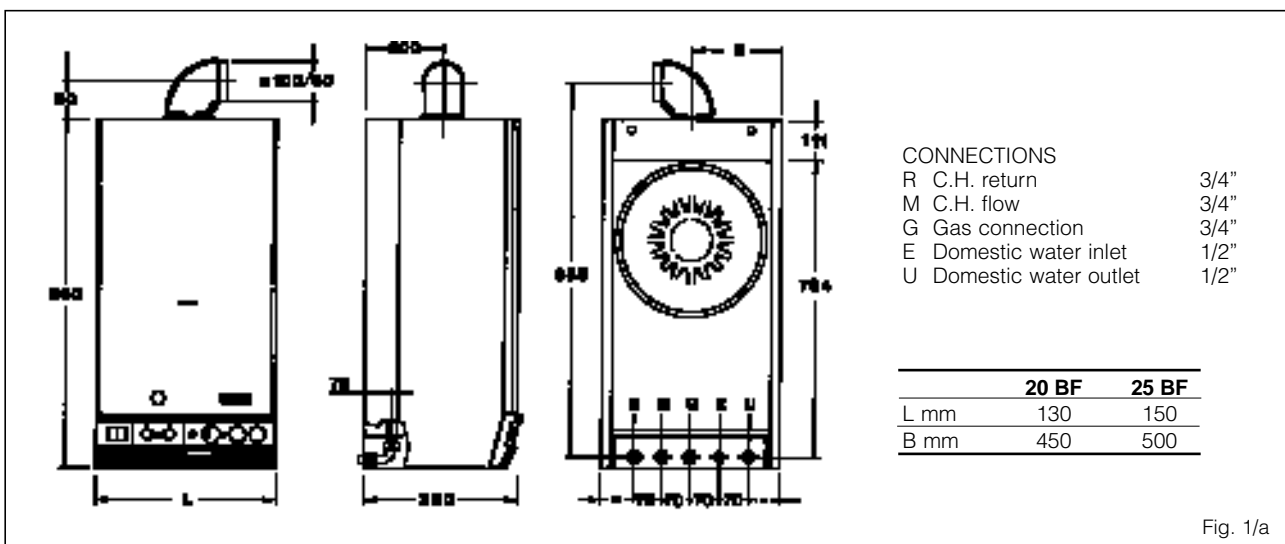

1.3 TECHNICAL FEATURES

TABLE 1

BOILER MODEL	Heat Output (adjustable) kW	Heat Input (adjustable) kW	Electr. protection grade W	Maximum water head bar	Expans. vessel contents l	Expans. vessel preloading bar	Weight Kg
MURELLE 20	9.3 ÷ 23.3	10.8 ÷ 25.7	–	3	7	1	40
MURELLE 25	11.6 ÷ 27.6	13.5 ÷ 30.6	–	3	7	1	48
MURELLE 20 BF	9.3 ÷ 23.3	10.8 ÷ 25.7	IP 44	3	7	1	48
MURELLE 25 BF	15.1 ÷ 29.6	18.0 ÷ 32.8	IP 44	3	7	1	54

TABLE 2

BOILER MODEL	Power consumption	Smokes temperature °C	Smokes flow gr/s	D.H.W. Heat Output kW	D.H.W. flow rate Δt 30°C l/min	Minimum D.H.W. flow rate l/min	D.H.W. pressure	
							Min. bar	Max. bar
MURELLE 20	105 (150 vers. TX)	100	24.7	23.3	11.0	2	0.5	7
MURELLE 25	120	100	29.4	27.6	12.9	2	0.5	7
MURELLE 20 BF	150	136	17.2	23.3	11.0	2	0.5	7
MURELLE 25 BF	160	136	22.8	29.6	12.9	2	0.5	7

TABLE 3

BOILER MODEL	Main burner nozzles			Pilot injector		Gas consumption (*)		
	Quantity N°	Natural gas ø mm	G30-G31 ø mm	Natural gas ø mm	G30-G31 ø mm	Natural gas m³/h	L.P.G. G30 kg/h	L.P.G. G31 kg/h
	MURELLE 20	13	1.30	0.75	0.25	0.20	2.72	2.02
MURELLE 25	15	1.30	0.77	-	-	3.23	2.41	2.37
MURELLE 20 BF	13	1.30	0.75	0.27	0.20	2.72	2.02	1.99
MURELLE 25 BF	15	1.30	0.77	-	-	3.47	2.58	2.54

(*) The gas consumptions refer to the calorific value at standard conditions at 15°C - 1013 mbar

TABLE 4

BOILER MODEL	Burner gas pressure			Gas supply pressure		
	Natural gas mbar	L.P.G. (G30) mbar	L.P.G. (G31) mbar	Natural gas mbar	L.P.G. (G30) mbar	L.P.G. (G31) mbar
MURELLE 20-20 BF	10	28	35	20	30	37
MURELLE 25-25 BF	11	28	35	20	30	37

NOTE: The burner header gas pressure and inputs shown in the table refer to the boiler max. capacity. These values must be kept to in the D.H.W. production.

1.4 FUNCTIONAL DIAGRAM

1.4.1 "MURELLE" model

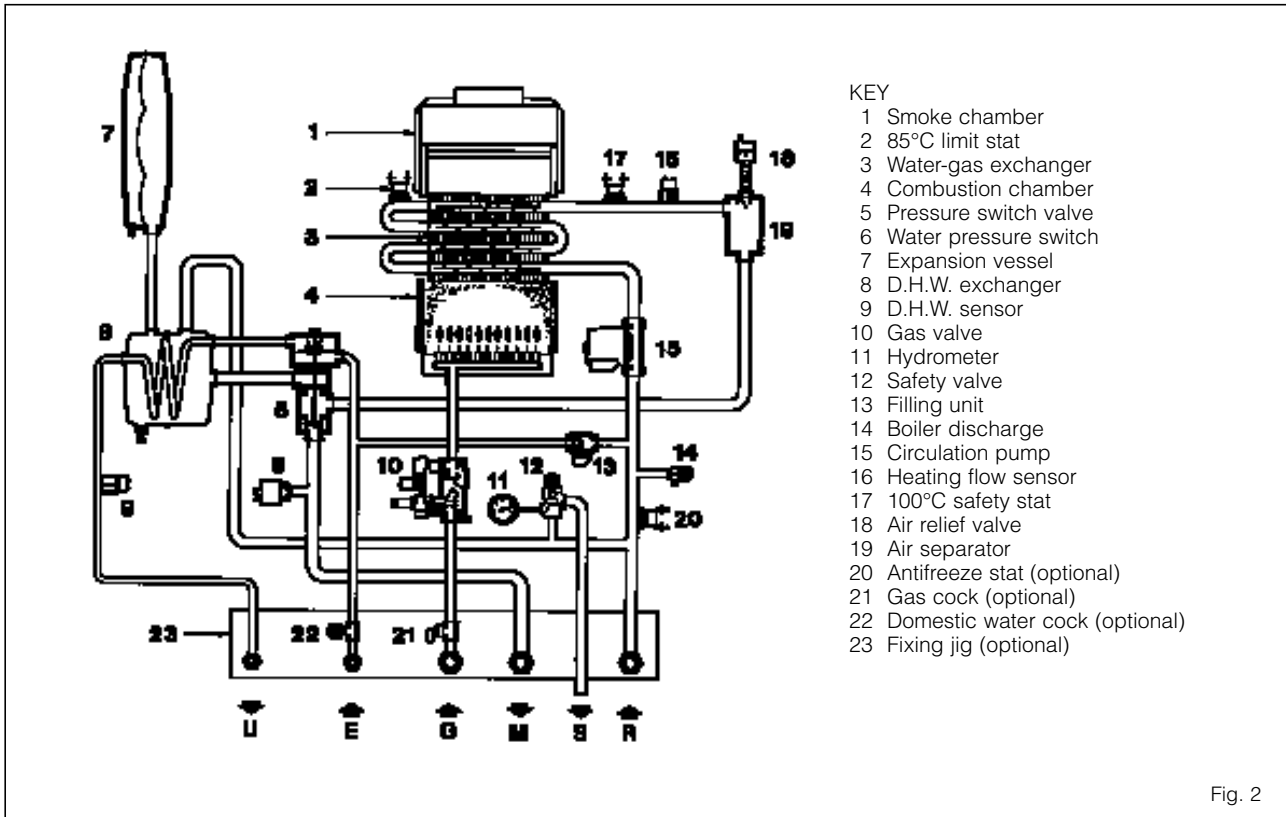

1.4.2 "MURELLE BF" model

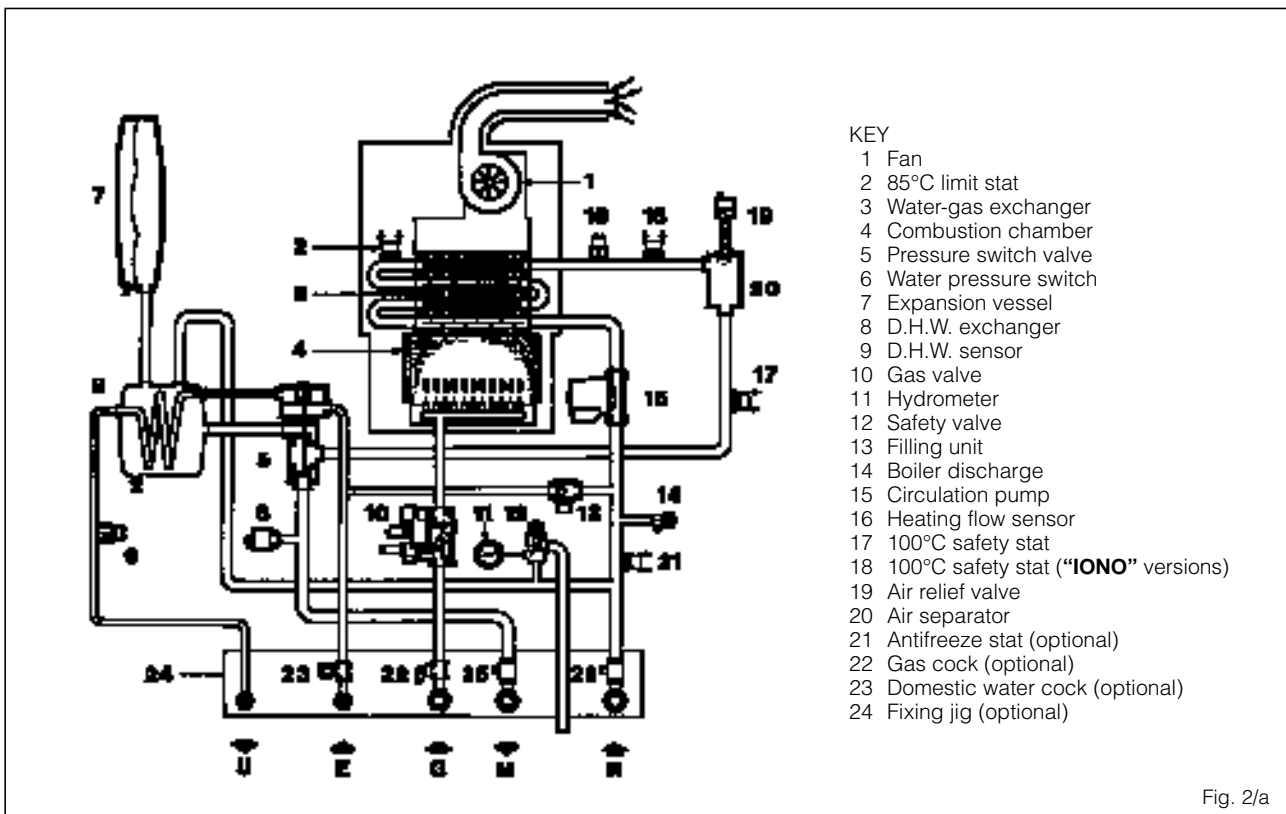

1.5 INTERNAL VIEW

1.5.1 "MURELLE" model

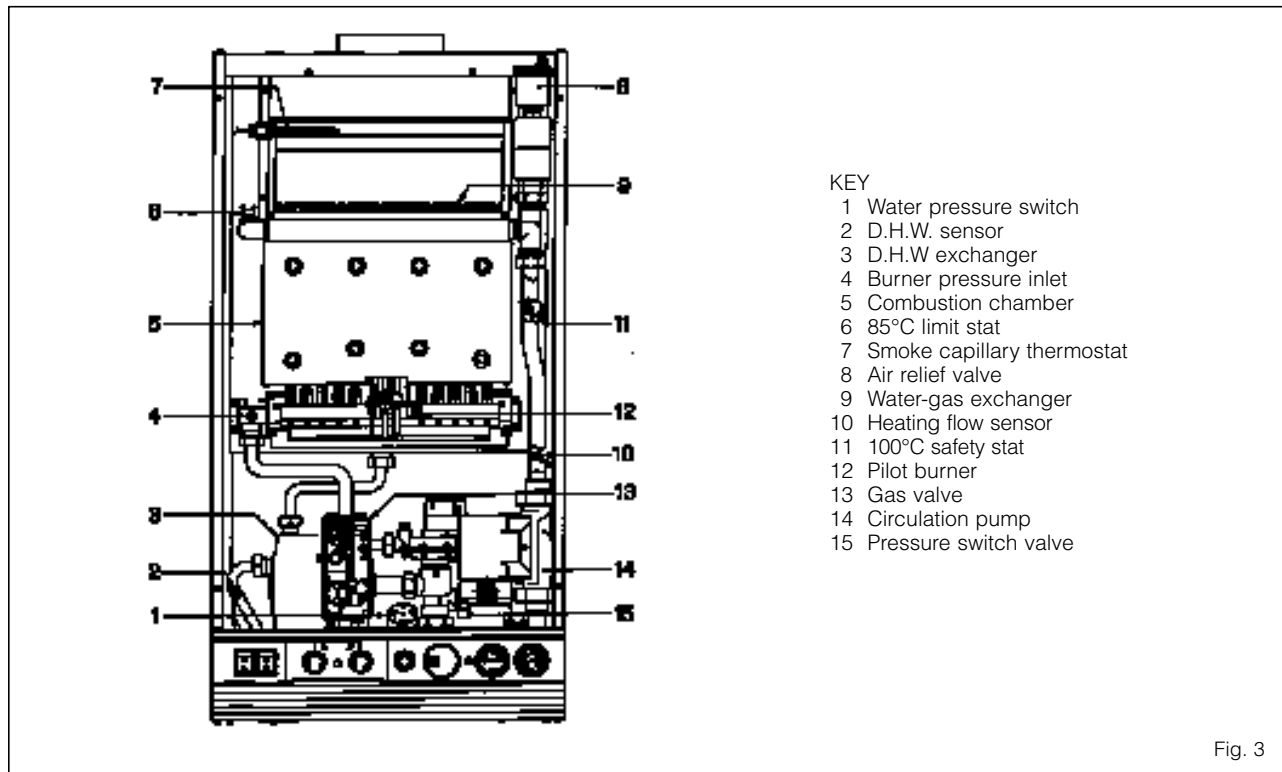

Fig. 3

1.5.2 "MURELLE BF" model

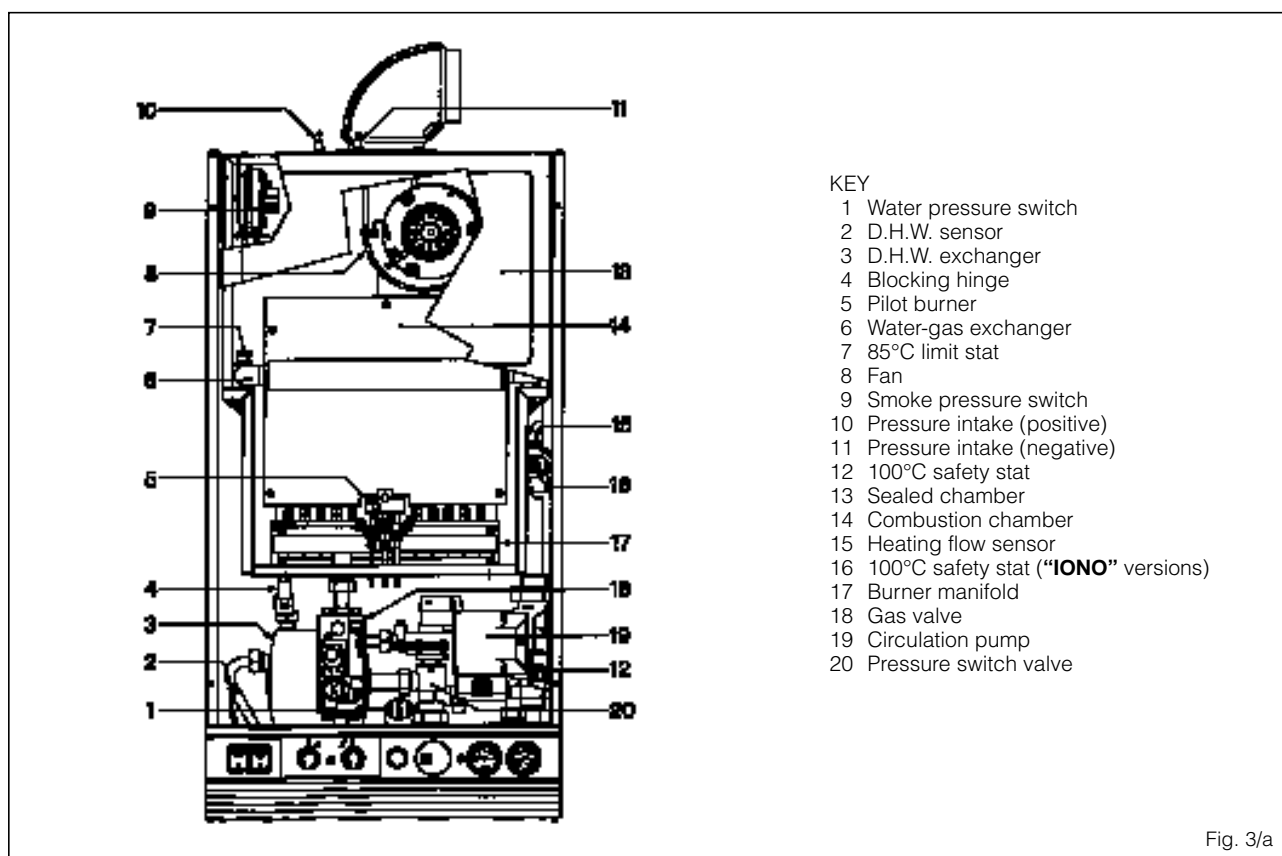

Fig. 3/a

1.6 SYSTEM AVAILABLE HEAD

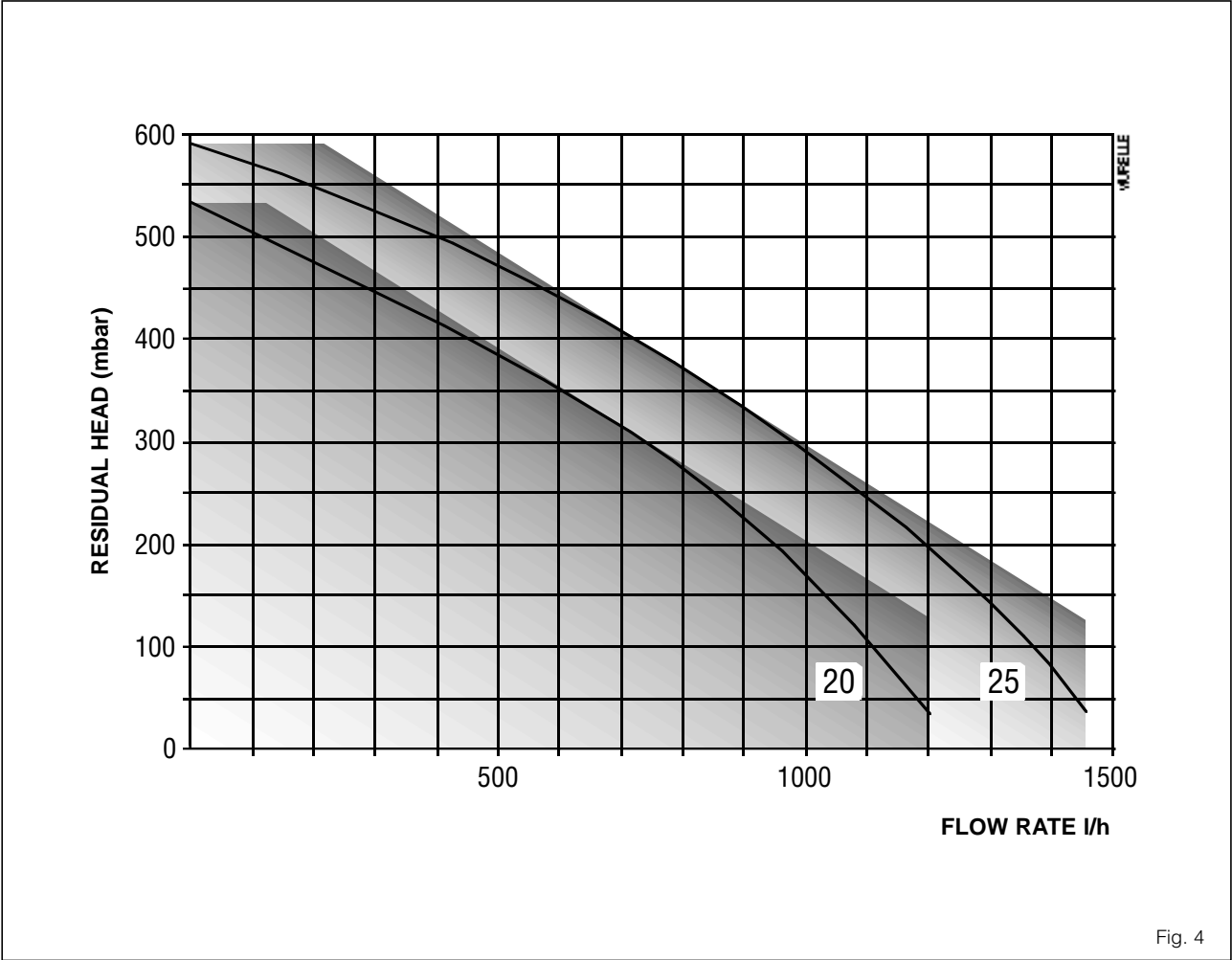

Fig. 4

2 General requirements for installation

The boiler should be installed in a fixed location and shall be carried out only by specialized and qualified firms in compliance with all instructions contained in this manual.

2.1 BOILER ROOM

The “MURELLE” version boilers may be installed in adequately ventilated domestic rooms.

The “MURELLE BF” version boilers may instead be installed, without any constraints regarding location or supply of air for combustion, in any domestic rooms.

2.2 VENTILATION OF BOILER ROOM FOR “MURELLE” BOILERS

It is essential that in rooms where open-flue gas appliances are installed at least as much air can arrive as required by normal combustion of the gas consumed by the various appliances. Consequently, it is necessary to make openings in the walls for entry of air into the rooms. These openings must meet the following requirements:

- have a total free section of at least 6 cm² for every kW of heat input, with a minimum of 100 cm² (such openings may possibly be obtained by widening the gap between the door and the floor);
- be situated towards the bottom of an external wall, preferably opposite the one in which the burnt gases outlet is located.

2.3 CONNECTING UP SYSTEM

Before proceeding to connect up the boiler, you are recommended to get air to circulate in the piping in order to eliminate any foreign bodies that might be detrimental to the operating efficiency of the appliance. When making the hydraulic connections, make sure that the dimensions indicated in Figs. 1 - 1/a are respected.

If the connections supplied with the fixing jig are not used for connecting up the pipes to the boiler, steel flexible pipes must be used so as to avoid any stress being exerted on the appliance.

In any case a shutoff valve must be mounted on the washing-water intake piping.

The discharge pipe of the safety valve (12 figs. 2 - 2/a) must be connected to a collector funnel for channelling away any discharge in the case of the safety valve going into action.

The gas connection must be made using seamless steel pipe (Mannesmann type), galvanized and with threaded joints provided with gaskets, excluding three-piece connections, except for initial and end connections.

Where the piping has to pass through walls, a suitable insulating sleeve must be provided. When sizing gas piping, from the meter to the boiler, take into account both the volume flow rates (consumption) in m³/h and the relative density of the gas in question. The sections of the piping making up the system must be such as to guarantee a supply of gas sufficient to cover the maximum demand, limiting pressure loss between the gas meter and any apparatus being used to not greater than:

- 1.0 mbar for family II gases (Natural gas)
- 2.0 mbar for family III gases (L.P.G.).

An adhesive data plate is stuck on the inside of the front panel; it contains all the technical data identifying the boiler and the type of gas for which the boiler is arranged.

2.4 WALL-MOUNTING PLATE

The wall-mounting plate is supplied along with the boiler in cardboard packaging, and consists of two plates, with a connecting strip and the corresponding fixing screws (Fig. 5).

For assembly, proceed as follows:

- fasten the connecting strip to the top plate A and the bottom plate B;
- once the template has been put together, fasten the plate A on the wall with the two hexagonal-head anchor bolts provided. The connecting strip will automatically set the bottom plate B in position;
- use a spirit level to check that the bottom plate B is perfectly horizontal, so as to achieve proper positioning and reference for laying all the water and gas pipes in place;
- attach the small bent tube connections or the connection cocks supplied in a kit (optional);
- finally, by means of the two hex screws of the top plate A, make the necessary adjustments to achieve perfect vertical positioning of the boiler.

For the “MURELLE” BF versions, make a hole in the wall sufficiently large to allow for insertion of a 130 mm \varnothing PVC pipe of the same length as the thickness of the wall it has to pass through. Then fix the PVC pipe in place using cement mortar. The purpose of the PVC pipe is to facilitate insertion of the coaxial air-intake flue-discharge assembly with its corresponding external gasket, as described in Section 2.6.1.

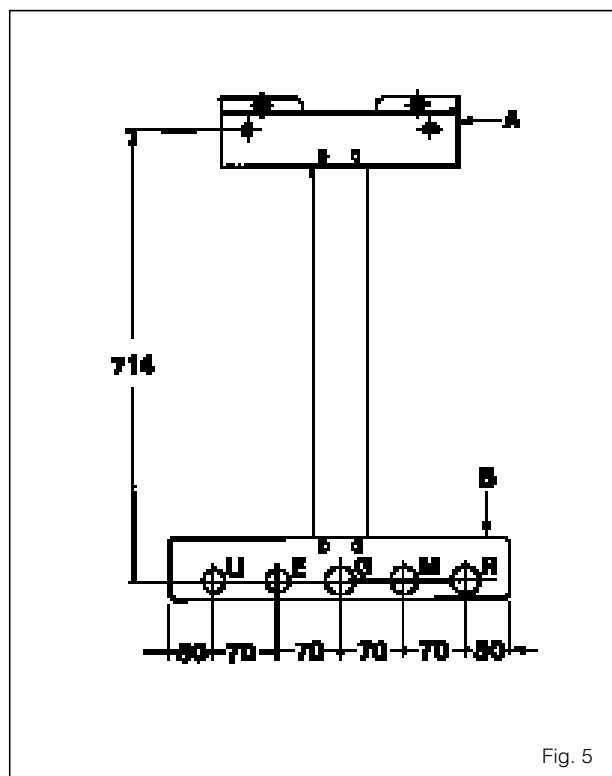

Fig. 5

2.5 CONNECTING UP “MURELLE” FLUE

The flue for expulsion into the atmosphere of the products of combustion from natural draught appliances must meet the following requirements:

- be gas-tight to the products of combustion, waterproof and thermally insulated;
- be built of materials suitable for resisting over time normal mechanical stresses, heat, and the action of products of combustion and their possible condensates;
- follow a vertical path and not present any throttling throughout its entire length;
- be adequately insulated to prevent phenomena of condensation or cooling of fumes, in particular if located outside the building or in unheated ambiences;
- be set at an adequate distance from combustible or easily inflammable material by means of an air gap or suitable insulating material;
- have beneath the mouth of the first smoke duct a chamber for collecting solid material and any condensate; the height of the chamber must be at least 50 mm. Access to the chamber must be guaranteed by means of an opening provided with an air-tight metal door;
- have a circular, square, or rectangular internal cross section; in the case of square or rectangular sections, the corners must be rounded off with a radius of not less than 20 mm. However, hydraulically equivalent cross sections are allowed;
- be equipped with a chimney-pot at the top, which must be outside the so-called back-flow zone, so as to prevent the formation of back-flow, which prevents free discharge of the products of combustion into the atmosphere;
- be devoid of mechanical means of suction located at the top of the pipe;
- no overpressure should be present in a chimney that passes within or close up to inhabited rooms.

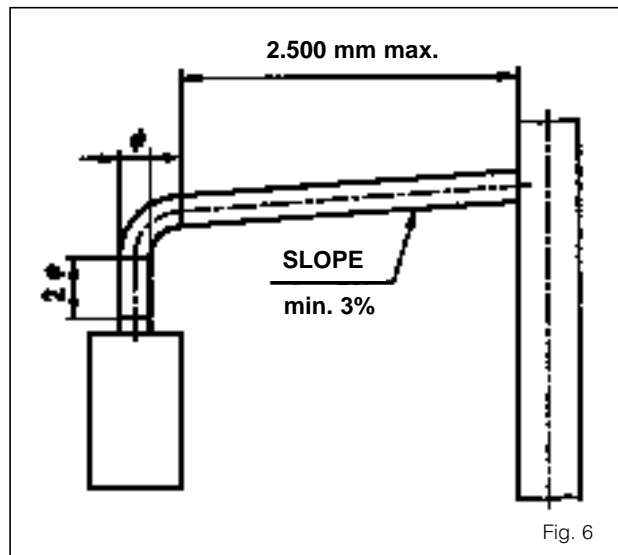
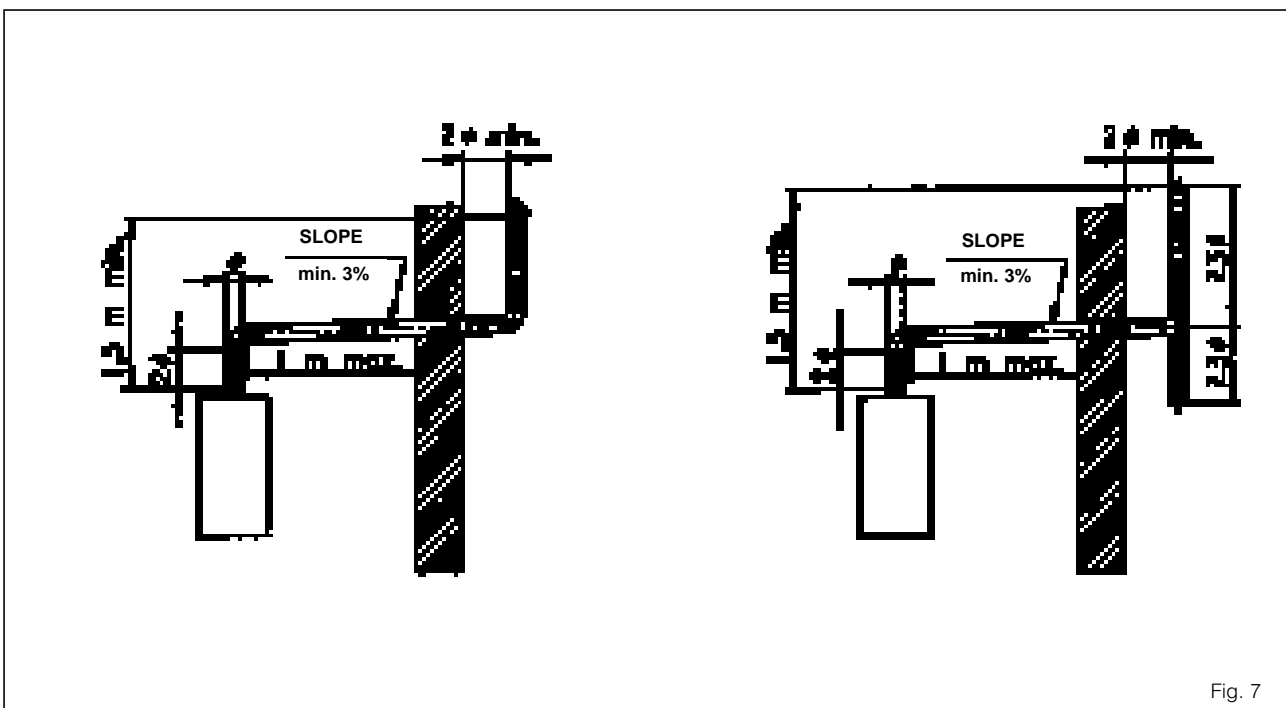

Fig. 6 refers to the connection of the boiler to the flue or chimney through smoke ducts. When making the connection, in addition to respecting the dimensions given, you are recommended to use gas-tight materials capable of resisting over time mechanical stresses and the heat of smokes. At any point along the smoke duct, the temperature of the products of combustion must be higher than dew point.

More than a total of three changes of direction must not be made, including the inlet connection to the chimney/flue. For any changes of direction use only curved lengths of pipe.

Fig. 7 shows some applications of draught terminals that ensure proper expulsion of products of combustion in case of discharge through the wall.



2.6 "MURELLE BF" COAXIAL AIR INLET-FLUE OUTLET ASSEMBLY

The air inlet-flue outlet assembly is supplied apart (optional) in a kit (Code 8084802). It includes:

- coaxial duct \varnothing 60/100, length 840, with wind-proof (anti-blowback) head already fixed to the flue discharge duct;
- pipe bend \varnothing 60/100 with fixing screws;
- fixing clamp;
- rubber ring nut for external closing;
- sponge-rubber gasket.

2.6.1 Assembly of the coaxial duct kit

For assembly follow closely what is indicated in Fig. 8.

- Make a hole in the wall sufficiently large to allow for insertion of a 130 mm \varnothing PVC pipe of the same length as the thickness of the wall it has to pass through. Then fix the PVC pipe in place using cement mortar.

WARNING: When cutting the pipe, remember that the 60 mm \varnothing flue discharge pipe must be approx. 25 mm longer than the air intake tube.

- Before sliding the pipe into the hole made in the wall, insert the rubber sealing ring (E) into its seat made in the tube.
- Push the tube outwards until the gasket comes out. Pull the pipe inwards bringing the ring to rest on the wall.
- Slide the inner ring (D) and the metal collar (I) onto the pipe.
- Push the flue discharge duct (F) fully home in the bend and fasten the metal collar (I) in position, tightening the two fixing screws.
- Fasten the duct (C) by tightening the two screws (H) on the aluminium ring nut (D).

NOTE: The air intake-flue outlet assembly must slope gently downwards to prevent rain water getting into the boiler.

2.6.2 Coaxial air intake-flue outlet assembly accessories

In addition to the coaxial duct kit, also the following can be supplied on request (Fig. 9):

- Extension \varnothing 60/100, length 855 (Code 8084800)
- Supplementary 90° pipe elbow \varnothing 60/100 (Code 8085600)
- Vertical extension \varnothing 60/100, length 590 (Code 8086900).

NOTE: With the pipe bend supplied in the kit, the maximum length of piping should not exceed 3 metres. In the case where the supplementary bend (4) is used, the total length of piping can reach a maximum of 1.6 m. When the vertical extension (3) is used, the terminal part of the pipe must always come out horizontally.

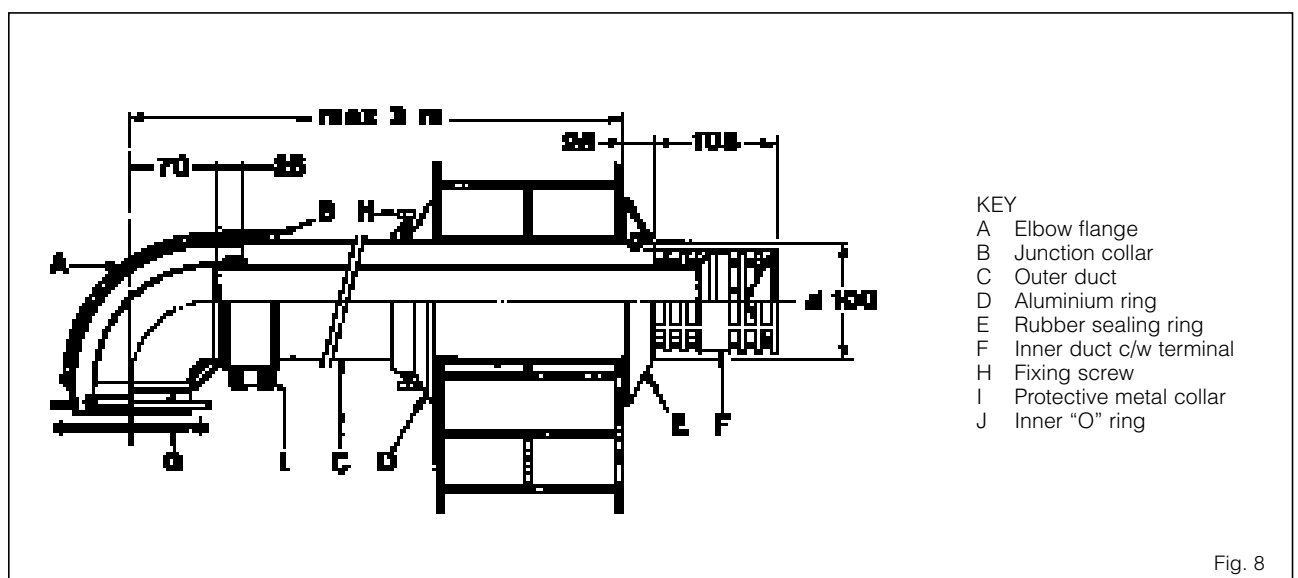
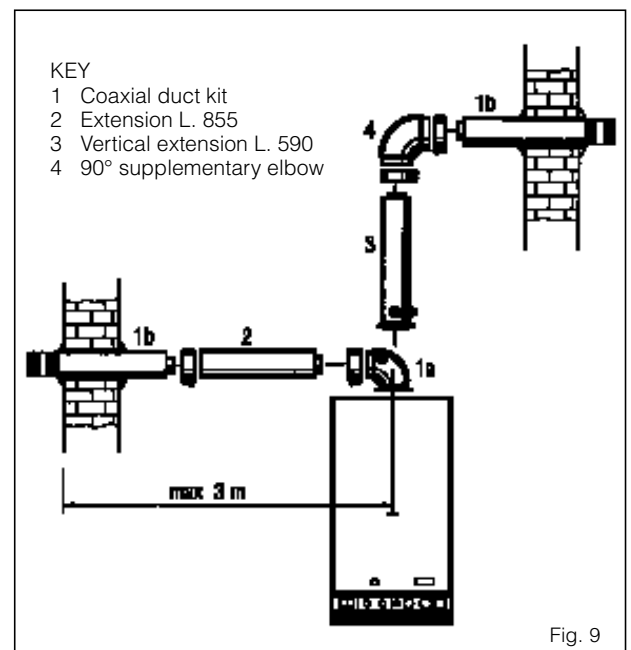

2.6.3 Positioning the outlet terminals

The outlet terminals for forced-draught appliances may be located in the external perimeter walls of the building. To provide some indications of possible solutions, Table 5 gives the minimum distances to be observed, with reference to the type of building shown in Fig. 10.

TABLE 5

Siting of terminal	Appliances from 7 to 35 kW (min. distances in mm)
A - Below openable window	600
B - Below ventilation opening	600
C - Below eaves	300
D - Below balcony (1)	300
E - From adjacent window	400
F - From adjacent ventilation opening	600
G - From vertical or horizontal soil or drain pipes (2)	300
H - From corner of building	300
I - From recess in building	300
L - From ground level or other treadable surface	2500
M - Between two terminals set vertically	1500
N - Between two terminals set horizontally	1000
O - From a surface facing, without openings or terminals	2000
P - As above, but with openings or terminals	3000

Notes

- 1) Terminals below a practicable balcony must be located in such a way that the total path of the smoke from its outlet point from the terminal to its outlet point from the external perimeter of the balcony, including the height of possible railings, is not less than 2000 mm.
- 2) When siting terminals, where materials that may be subject to the action of the products of combustion are present in the vicinity, e.g., eaves, gutters and downspouts painted or made of plastic material, projecting timberwork, etc., distances of not less than 1500 mm must be adopted, unless adequate shielding is provided to guard these materials.

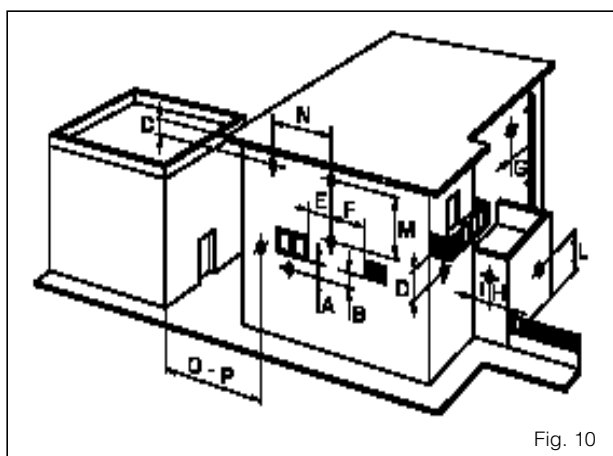

Fig. 10

2.6.4 Coaxial duct outlet on roof

To install this type of arrangement, the following are available as optionals:

- roof outlet terminal \varnothing 60/100, length 1280 (Code 8091200);
- articulated-joint roof tile (Code 8091300);
- extension \varnothing 60/100, length 855 (Code 8084804);
- supplementary 90° elbow \varnothing 60/100 (Code 8085601);
- vertical extension \varnothing 60/100, length 200 (Code 8086903).

When assembling the accessories, remember that the roof discharge terminal (length 1280 mm) cannot be shortened and that the articulated joint of the roof tile allows roof pitches of between 25° and 45°.

The tile is a plane roofing tile (1, Fig. 11) and comes fitted with a shaped and folded lead panel (dimensions 160 x 440) for adaptation to the roof.

When joining the tile to the terminal, use the collar inserted on the latter (3, Fig. 11), fastening it in position with the three self-tapping screws provided.

When positioning the roof tile make sure to leave a distance of not less than 600 mm from the discharge top of the roof-outlet terminal.

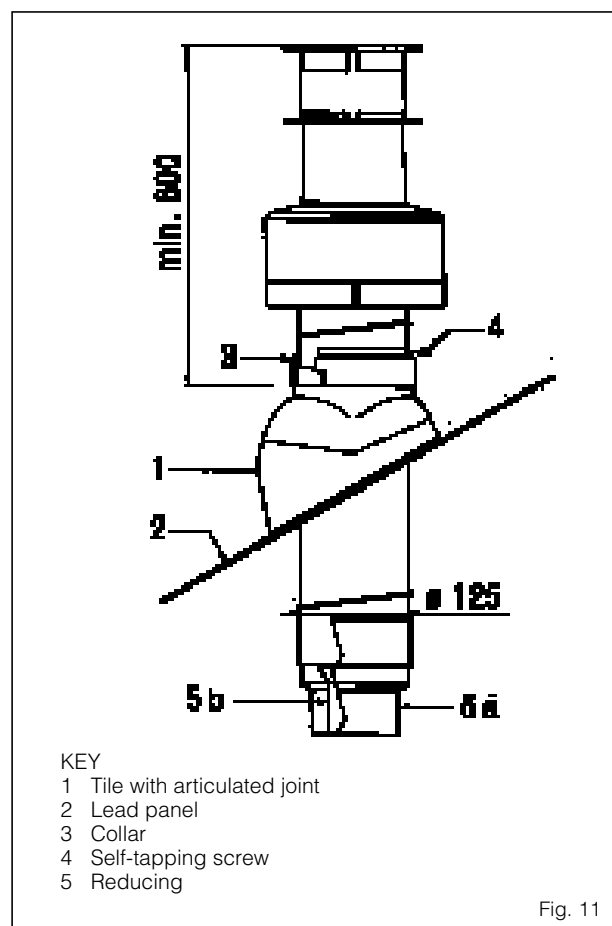

- KEY
- 1 Tile with articulated joint
 - 2 Lead panel
 - 3 Collar
 - 4 Self-tapping screw
 - 5 Reducing

Fig. 11

It is possible to insert up to a maximum of three extensions and reach a maximum rectilinear distance of 3.7 m. Should it be necessary to make two changes of direction in the pipe development, the maximum length of the pipe must not exceed 2 m.

It is not allowed to replace SIME accessories with other devices. Some of the connecting systems that may be adopted are shown in Fig. 12.

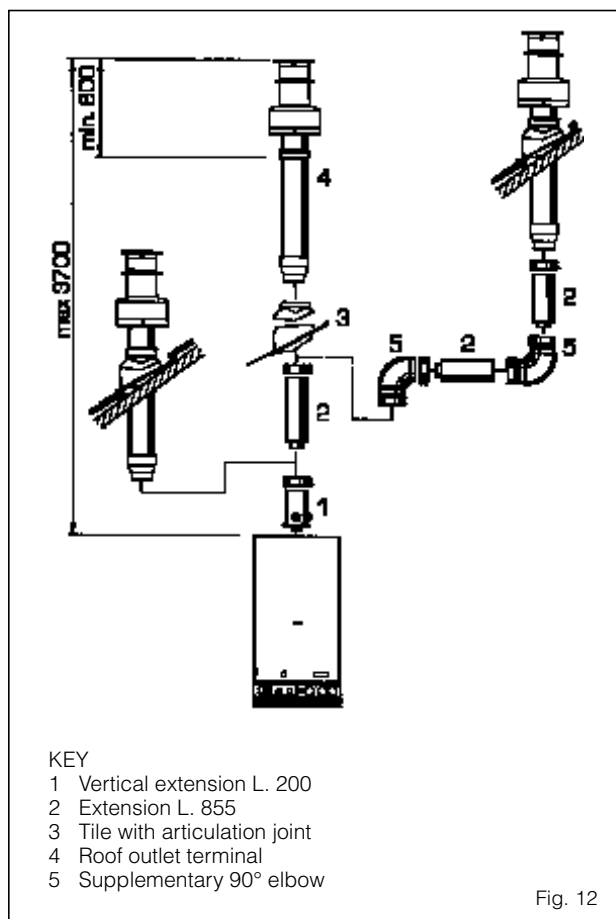

2.7 "MURELLE BF" SEPARATE AIR INTAKE-FLUE OUTLET PIPES

The sum of the development of the air intake-flue outlet pipes enables a maximum distance of 16 m to be reached without change of direction.

When installing the pipes, follow closely the requirements of current standards, as well as the following practical pointers:

- the temperature on the surface of the discharge pipe, in the portions that pass through masonry and/or come into contact with walls should not exceed room temperature by more than 60°C (pr EN 483);
- with direct intake from outside, when the pipe is longer than 1 m, you are recommended to insulate the piping so as to prevent formation of dew on the outside of the piping during particularly severe periods of the year;
- with the outlet pipe outside the building or in cold indoor environments, insulation is necessary to prevent burner failure in starting. In such cases, provide for a condensate-collector system on the piping.

2.7.1 Assembly of separate-pipe kit

The accessories needed for assembly are available on request in a kit (Code 8089902). The kit includes (Fig. 13/a):

- Discharge pipe flange \varnothing 80 mm with fixing screws and lip seal \varnothing 90
- Sponge-rubber gasket
- Air diverter with fixing screws ("20 BF" vers.)
- Air-intake pipe collar \varnothing 80 with fixing screws, sectored diaphragm \varnothing 38 and lip seal \varnothing 90

The sectored diaphragm \varnothing 38 is to be used according to the maximum head loss allowed in both pipes, as given in Table 6.

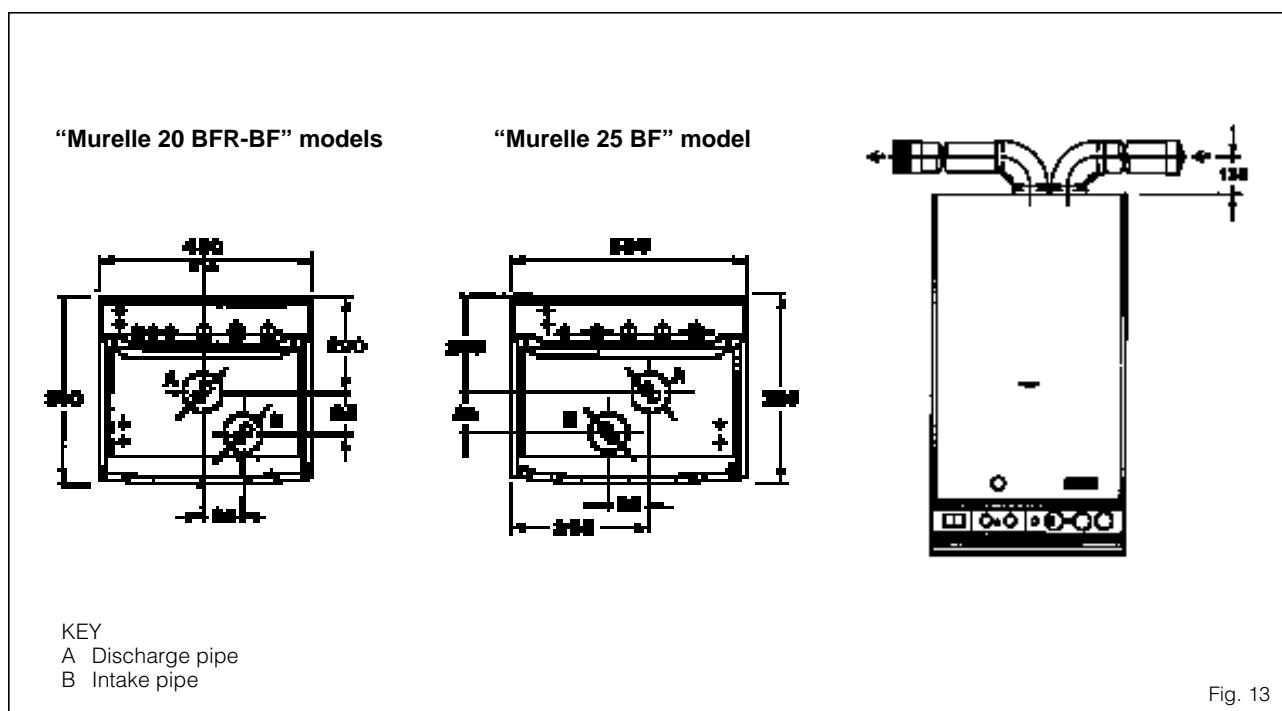

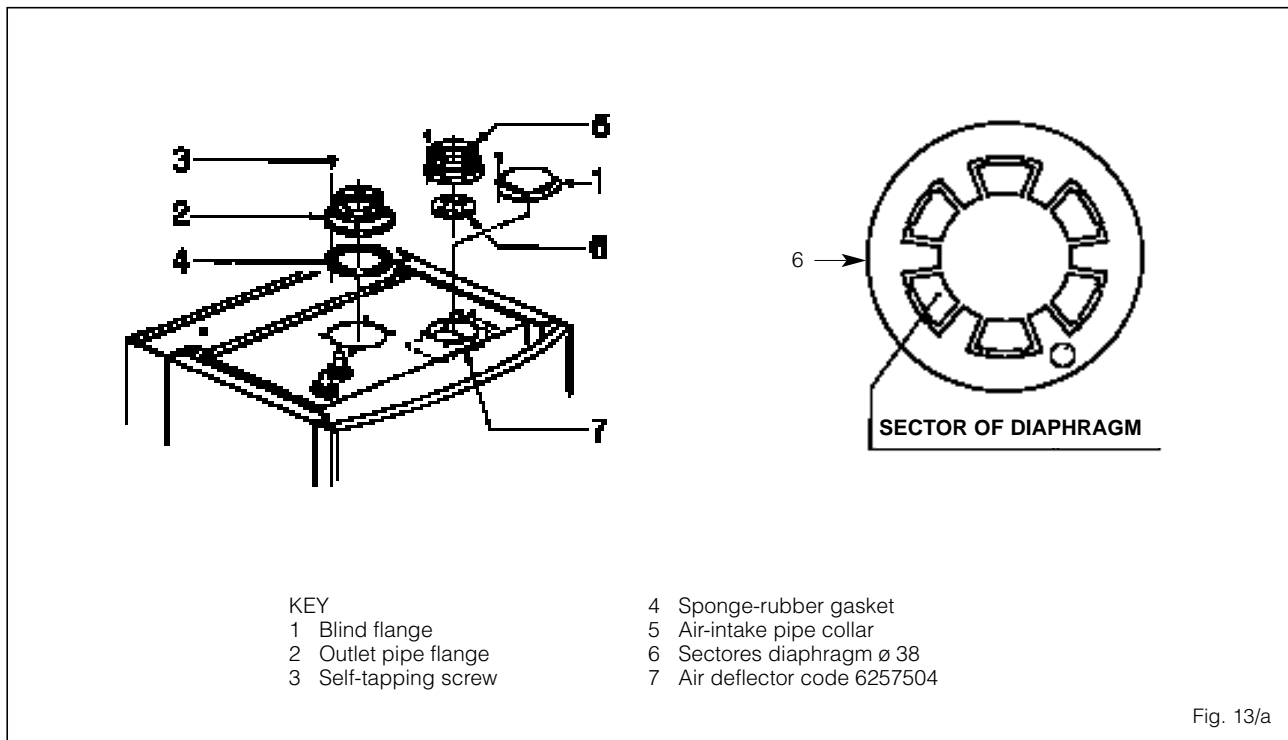

TABLE 6

Murelle 20 BF			Murelle 25 BF		
Sectors of diaphragm to remove	Total head loss		Sectors of diaphragm to remove	Total head loss	
	mm H ₂ O	Pa		mm H ₂ O	Pa
			None	0 ÷ 1	0 ÷ 9.8
1	0 ÷ 1	0 ÷ 9.8	1	1 ÷ 2	9.8 ÷ 19.6
2	1 ÷ 2	9.8 ÷ 19.6	2	2 ÷ 3	19.6 ÷ 29.4
4	2 ÷ 3	19.6 ÷ 29.4	4	3 ÷ 4	29.4 ÷ 39.2
6	3 ÷ 4	29.4 ÷ 39.2	6	4 ÷ 5	39.2 ÷ 49.0
Remove diaphragm	4 ÷ 5	39.2 ÷ 49.0	Remove diaphragm	5 ÷ 6	49.0 ÷ 58.8

2.7.2 Separate-pipe kit accessories

In addition to the separate-pipe kit, also available on request are the following (Fig. 14):

- 90° pipe elbow MF ø 80 (Code 8077404);
- 90° pipe elbow MF ø 80 with intake (Code 8077407);
- extension ø 80, length 1000 (Code 8077303);
- extension ø 80, length 130 with intake (Code 8077304);
- air-intake terminal ø 80 (Code 8089500);
- discharge terminal ø 80 (Code 8089501);
- locking junction for separate flue kits ø 80 (n° 5) (Code 8092700);
- int.-ext. ring kit ø 80 (Code 8091500);
- 45° elbow MF ø 80 (Code 8077406);
- condensation outlet ø 80 (Code 8092800).

The distance between the boiler and air-intake or flue-outlet point is not fixed, but must be determined according to the particular case by adding together the head losses of both pipes. To make the calculation, take into account the following parameters:

- for every metre of pipe ø 80 (intake or outlet), the average

head loss is 0.21 mm H₂O;

- for every pipe bend ø 80, the average head loss is 0.35 H₂O.

NOTE: The maximum head loss allowed for both pipes (intake and outlet) must not exceed 5 mm H₂O.

Example:

Assuming that the length of each pipe is 4 metres, and 2 bends are made, the head loss will be

8 metres of pipe ø 80 x 0.21 = 1.68 mm H₂O

2 - 90° elbows ø 80 x 0.35 = 0.70 mm H₂O

Total head loss 2.38 mm H₂O

With this total head loss, remove four sectors of diaphragm to be used in the air-intake pipe (Fig. 13/a).

Below are illustrated some of the connecting systems that may be adopted (Fig. 14).

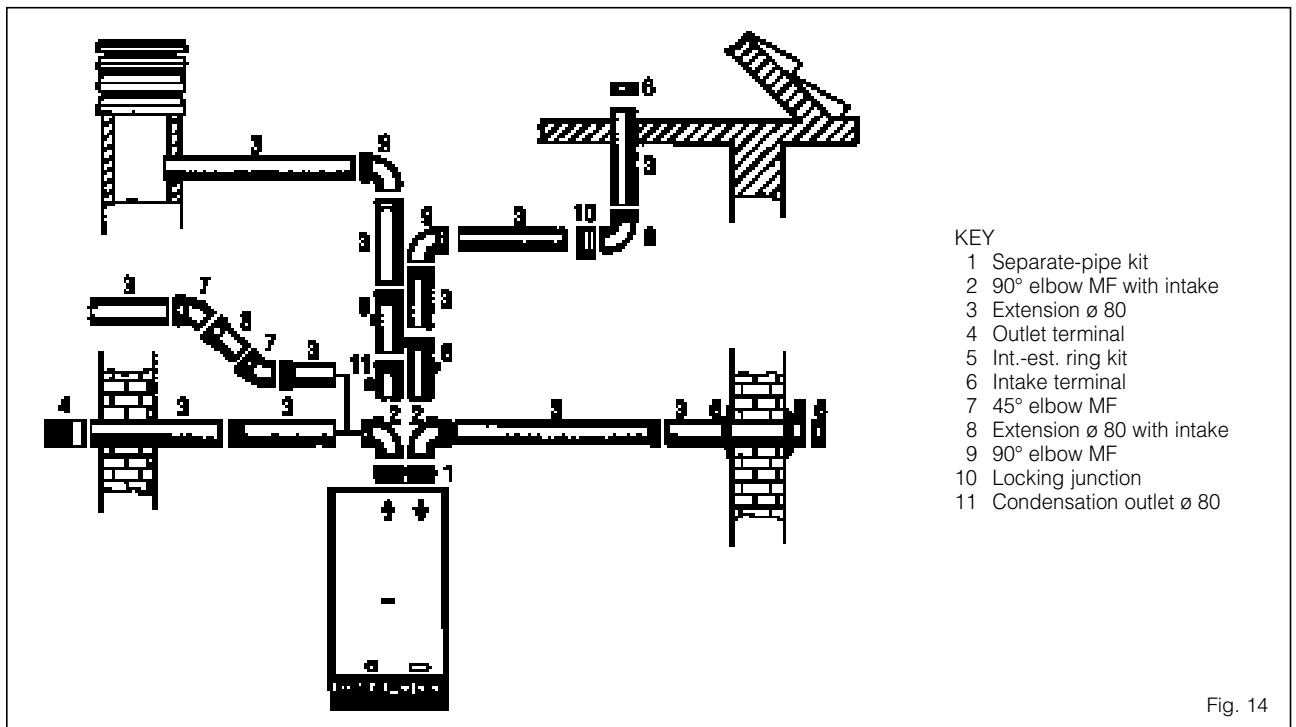

Fig. 14

2.7.3 Separate-pipes roof outlet

To install this kind of arrangement, the following are available on request:

- roof outlet terminal ø 80, length 1240 mm (Code 8091201);
- tile with articulated joint (Code 8091300);
- extension ø 80, length 1000 (Code 8077303);
- int.-ext. ring kit ø 80 (Code 8091500);
- 90° pipe elbow MF ø 80 (Code 8077404);
- locking junction for separate flue kits ø 80 (n° 5) (Code 8092700)
- air-intake terminal ø 80 (Code 8089500);
- doubler fitting (Code 8091400);
- separate-pipes kit ø 80 (Code 8089902);
- 45° elbow MF ø 80 (Code 8077406);
- extension ø 80, length 130 with intake (Code 8077304);
- 90° elbow MF ø 80 with intake (Code 8077407);
- condensation outlet ø 80 (Code 8092800)

When assembling the accessories, remember that the roof outlet terminal (length 1240 mm) cannot be shortened and that the articulated joint of the roof tile allows roof pitches between 25° and 45°. The tile is a plane roofing pipe (1, Fig. 17) and is provided with a shaped and folded lead panel (dimensions 160 x 440) for adaptation to the roof. When joining the tile to the terminal, use the collar inserted on the latter (3, Fig. 17), fastening it in position with the three self-tapping screws provided. When positioning the roof tile make sure to leave a distance of not less than 430 mm from the discharge top of the roof-outlet terminal. There is the possibility of doubling the air-intake and smoke-outlet pipes and then bringing them back together again so as to obtain a concentric discharge by using the doubler fitting (7, Fig. 17 bis). In these cases, when assembling, recover the silicone gasket used on the terminal adapter (5, Fig. 17), which is to be replaced by the doubler, and insert it into the seat made

in the doubler. **For this type of discharge the sum of the maximum rectilinear development allowed for the pipes must not exceed 16 metres. Pipe bends may be inserted, but remember that each bend penalizes the rectilinear stretch by 1 m, both on the smoke discharge and on the air intake portions of piping.**

When calculating the lengths of pipe, take into account the parameters given in section 2.7.2.

Below are illustrated some of the connecting systems that may be adopted (Fig. 17 bis).

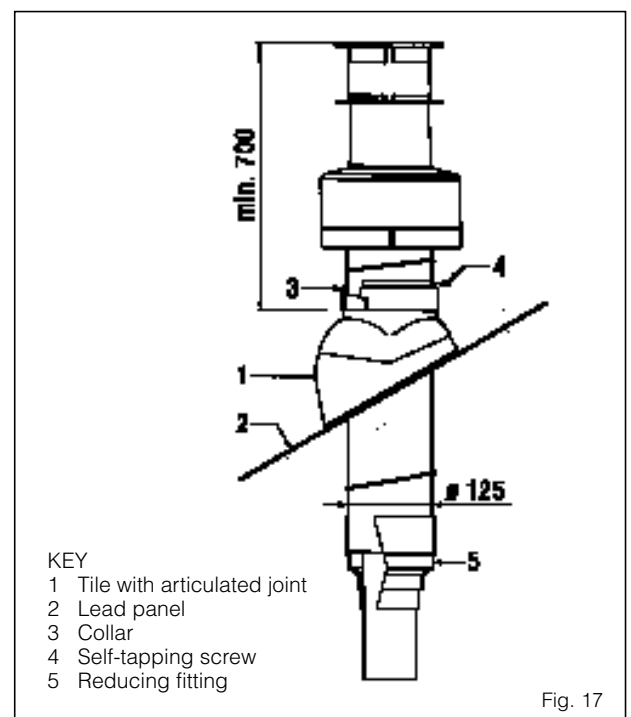
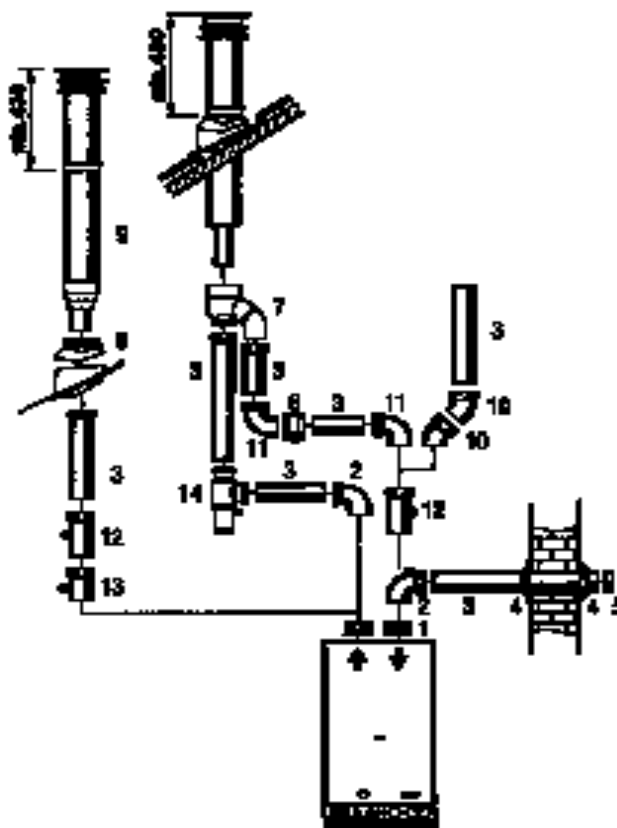

Fig. 17



- | | |
|-----|-----------------------------|
| KEY | |
| 1 | Separate-pipes kit |
| 2 | 90° elbow MF with intake |
| 3 | Extension ø 80 |
| 4 | Int.-est. ring kit |
| 5 | Intake terminal |
| 6 | Locking junction |
| 7 | Doubler fitting |
| 8 | Tile with articulated joint |
| 9 | Roof outlet terminal ø 80 |
| 10 | 45° elbow MF |
| 11 | 90° elbow MF |
| 12 | Extension ø 80 with intake |
| 13 | Condensation outlet ø 80 |

Fig. 17 bis

2.8 CHARACTERISTICS OF FEEDWATER

Where the mains water has a hardness of more than 20 - 25° Fr, the feedwater must be suitably softened both for the hot water circuit and for the central heating circuit, so as to prevent formation of boiler scale due to lime deposits, since this could lead to a reduced heat exchange.

It should be remembered that even small encrustations of just a few millimetres thick, on account of their low thermal conductivity, cause a considerable overheating of the walls of the boiler with serious consequences.

IT IS ABSOLUTELY ESSENTIAL THAT THE WATER USED FOR THE CENTRAL HEATING SYSTEM SHOULD BE TREATED IN THE FOLLOWING CASES:

- very extensive system (with high contents of feedwater)
- frequent addition of makeup water into the system.

Should it be necessary to empty the system either partially or totally, the subsequent refilling should be carried out using suitably treated water.

2.9 WATER FAILURE SAFETY DEVICE

The boiler is equipped with a water pressure switch set at 0.6 bar (1, Figs. 3 - 3/a), which goes into action, blocking boiler operation, whenever the pressure inside the boiler is less than the calibration value.

When the pressure switch trips, a red warning lamp lights up (7, Fig. 18).

To restore burner operation, turn the charge cock and bring the pressure back to between 1 and 1.2 bar.

2.10 SYSTEM FILLING

Filling of the boiler and the system is done by opening the ball cock located on the underside of the boiler (Fig. 16) and the charge cock located on the fixing jig in the “**20 R CE IONO**” version. The charge pressure, with the system cold, must be between 1 and 1.2 bar. During system filling you are recommended to keep the main switch turned OFF. Filling must be done slowly so as to allow any air bubbles to be bled off through the air valves.

Should system pressure drop during operation, as a result

of gases dissolved in the water, to values of less than 0.6 bar, the burner will go out automatically, and the warning light (7, Fig. 18) will start flashing to recall the User's attention. The charge cock must be opened to bring the pressure back up to 1-1.2 bar, as indicated on the hydrometer. Once the pressure is restored, the warning lamp will turn off automatically and the boiler will start up again. After carrying out this operation, check that the cock is closed. Should the pressure have risen well above the limit expected, discharge the over pressure by opening the pressure-relief valve on any of the radiators.

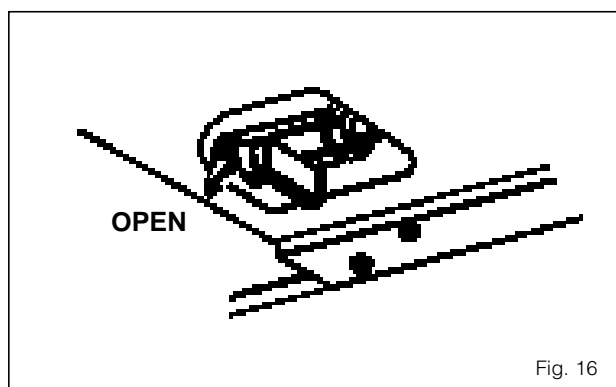

Fig. 16

2.11 "MURELLE 20 TX CE IONO" BOILER SUPPLY

The boilers are shipped in two separate packages:

1) Boiler and 90° elbow, and 2) Smoke discharge pipe \varnothing 60, length 600, with rubber ring for external closing and terminal with anti-blowback (wind-protection) device.

The following optionals are also available:

- discharge pipe extension \varnothing 60, length 1000 (Code 8077302);
- 90° elbow \varnothing 60 (Code 8077403);
- extension \varnothing 60, length 125, with fume intake (Code 8077305).

By turning the 90° elbow, it is possible to orient the boiler smoke outlet in any direction (Fig. 17)

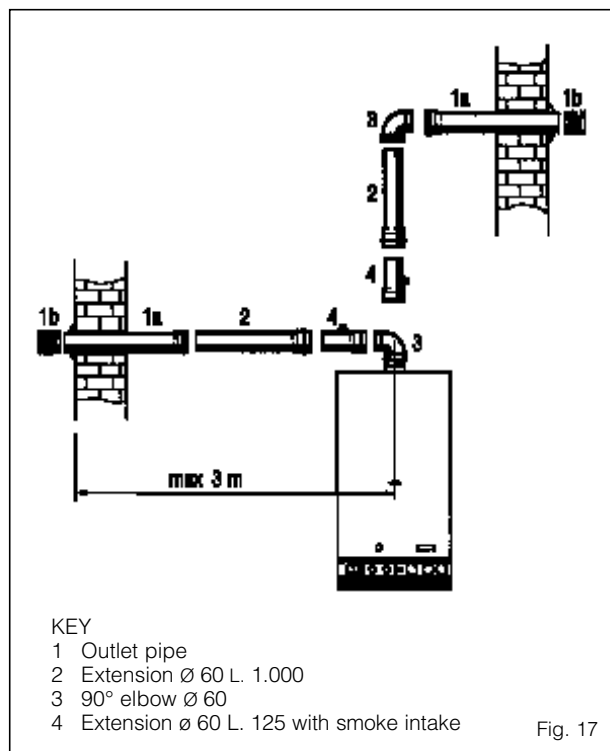

Fig. 17

2.11.1 Installation of "MURELLE 20 TX CE IONO" boiler

To install the boiler, proceed as follows (Fig. 17/a):

- once you have chosen the position for the discharge pipe (1, Fig. 17), make a hole \varnothing 80 in the masonry;
- adapt the length of the outlet pipe to the actual thickness of the wall. With the extensions supplied on request, it is possible to reach a maximum useful length between the appliance and the external wall surface of 3 m;
- mount the rubber ring and the terminal with wind-protection device on the pipe.

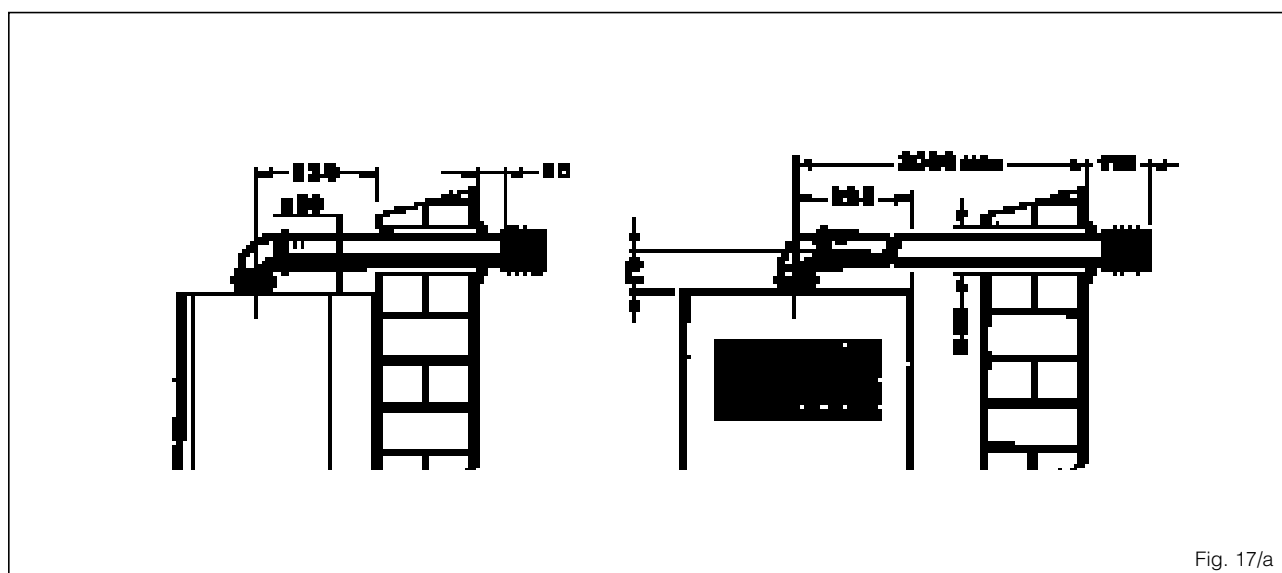

Fig. 17/a

2.12 ELECTRICAL CONNECTION

The boiler is supplied with an electric cable. Should this require replacement, it must be purchased exclusively from SIME. The electric power supply to the boiler must be 230 V - 50 Hz single-phase through a fused main switch, with at least 3-mm spacing between contacts. You are recommended to install a room temperature thermostat to ensure better regulation of temperature and comfort of indoor ambience.

This thermostat must be Class II, in compliance with the Standard EN 60730.1.

NOTE: SIME declines all responsibility for injury or damage to persons, animals or things, resulting from the failure to provide for proper earthing of the appliance.

2.12.1 Electric switchboard

To gain access to the switchboard inside the appliance, unscrew the two screws that fasten it to the rear panel (2, Fig. 27). The switchboard will tilt downwards at an adequate angle to enable easy access to the components.

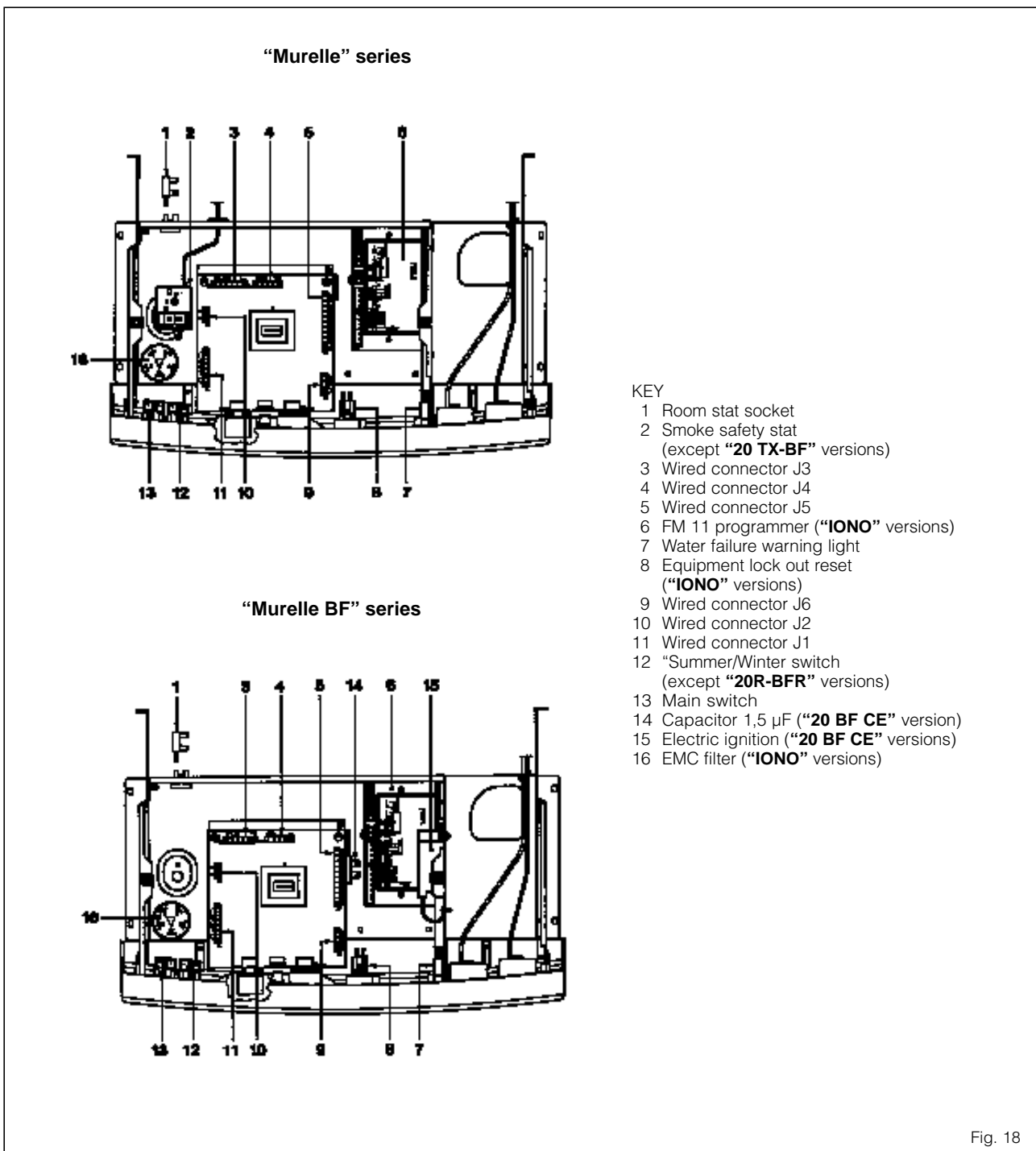

2.12.2 "MURELLE 20R CE IONO" wiring diagram

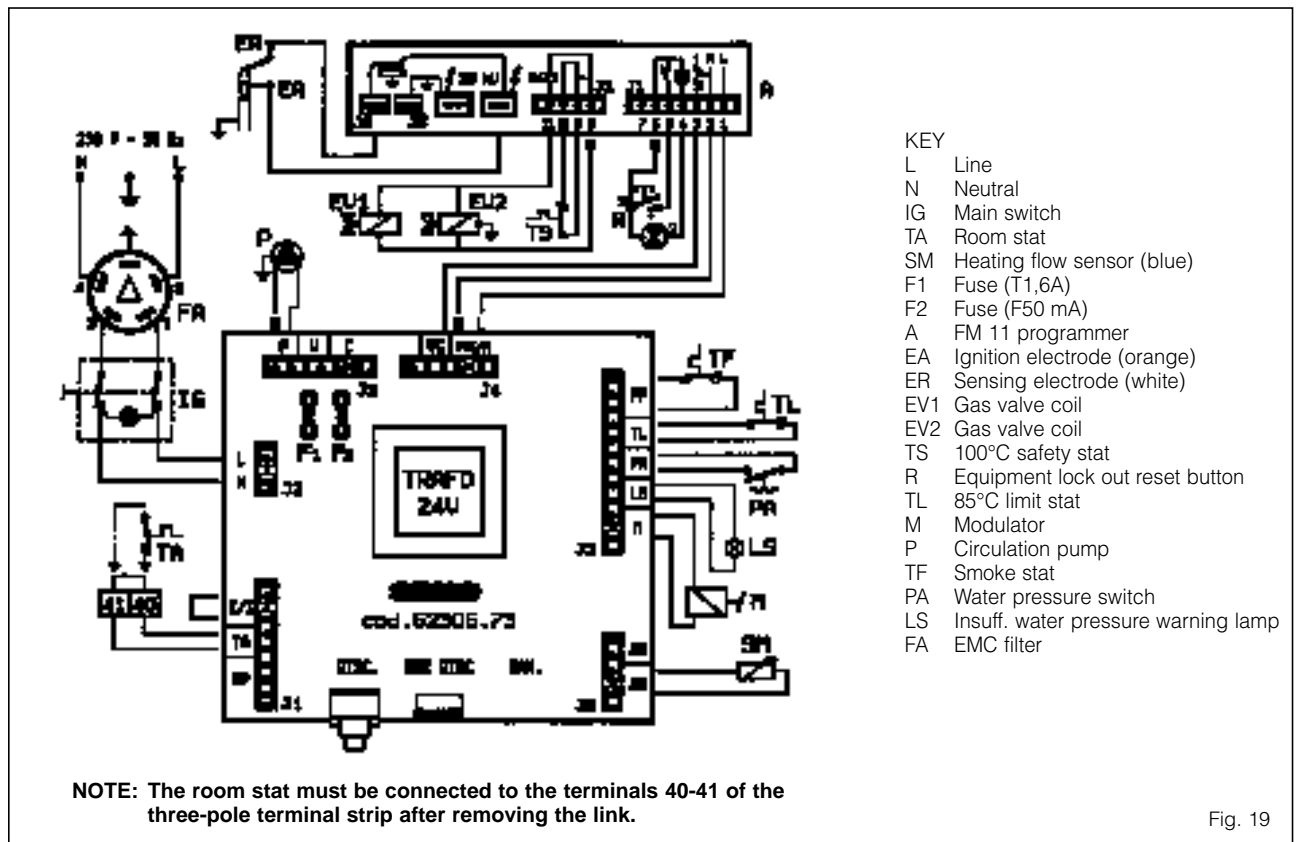

2.12.3 "MURELLE 20 CE" wiring diagram

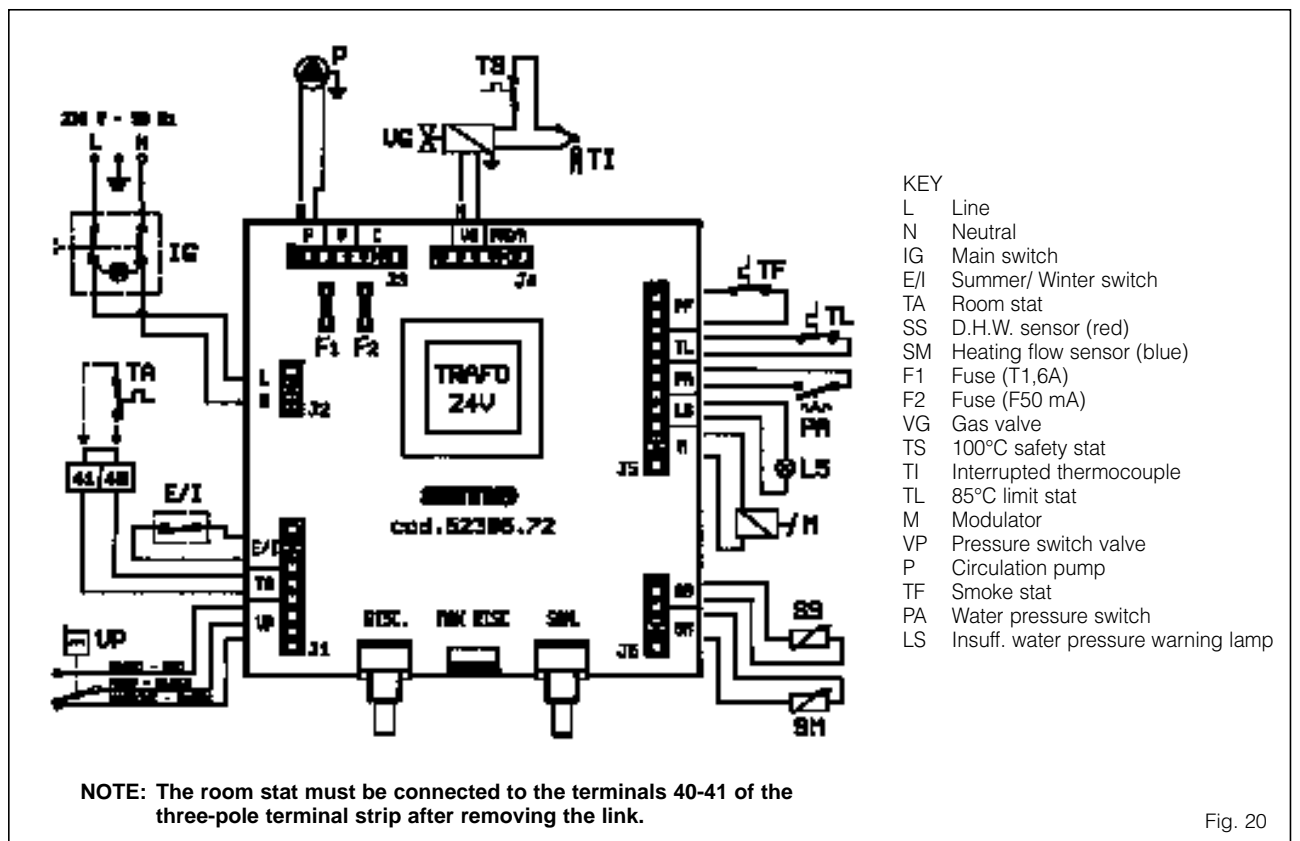

2.12.4 "MURELLE 20 CE IONO - 25 CE IONO" wiring diagram

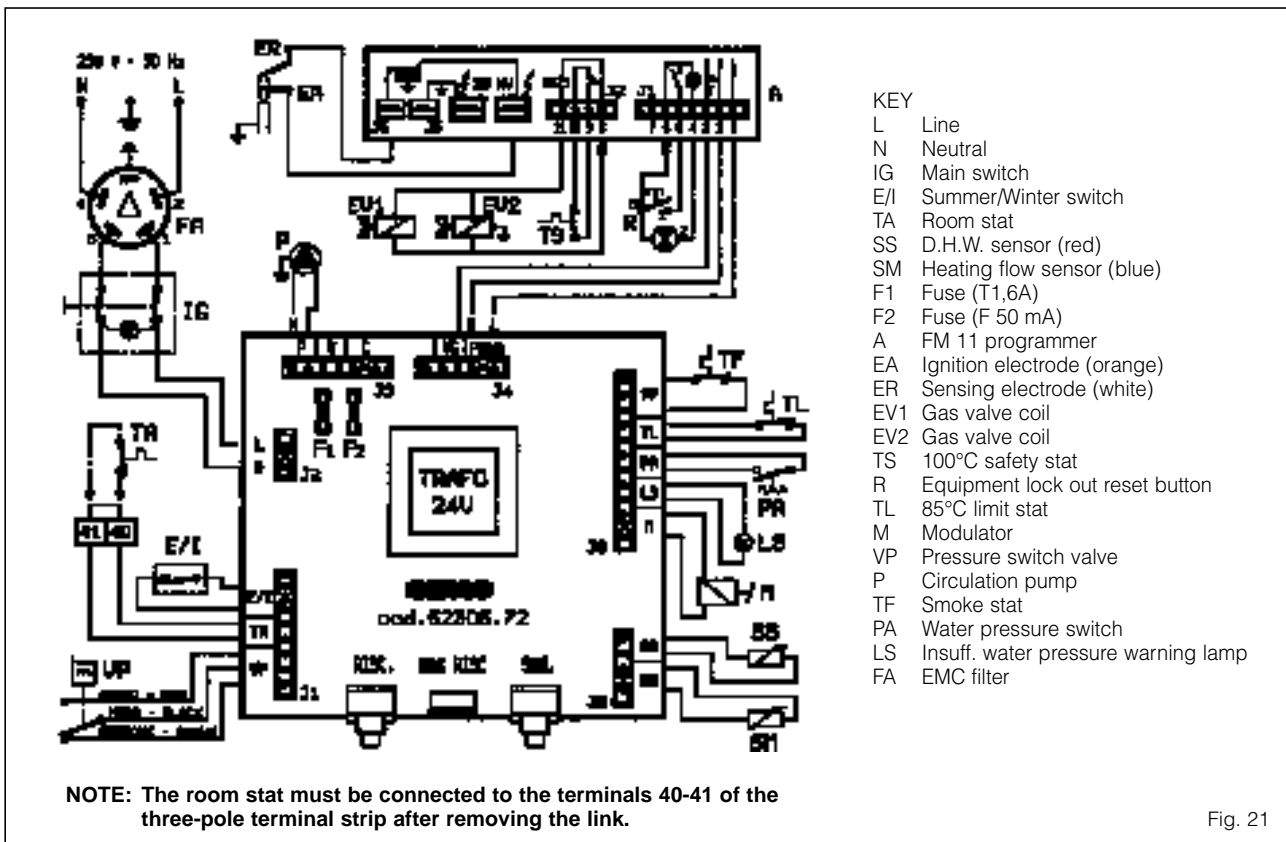

2.12.5 "MURELLE 20 BFR CE IONO" wiring diagram

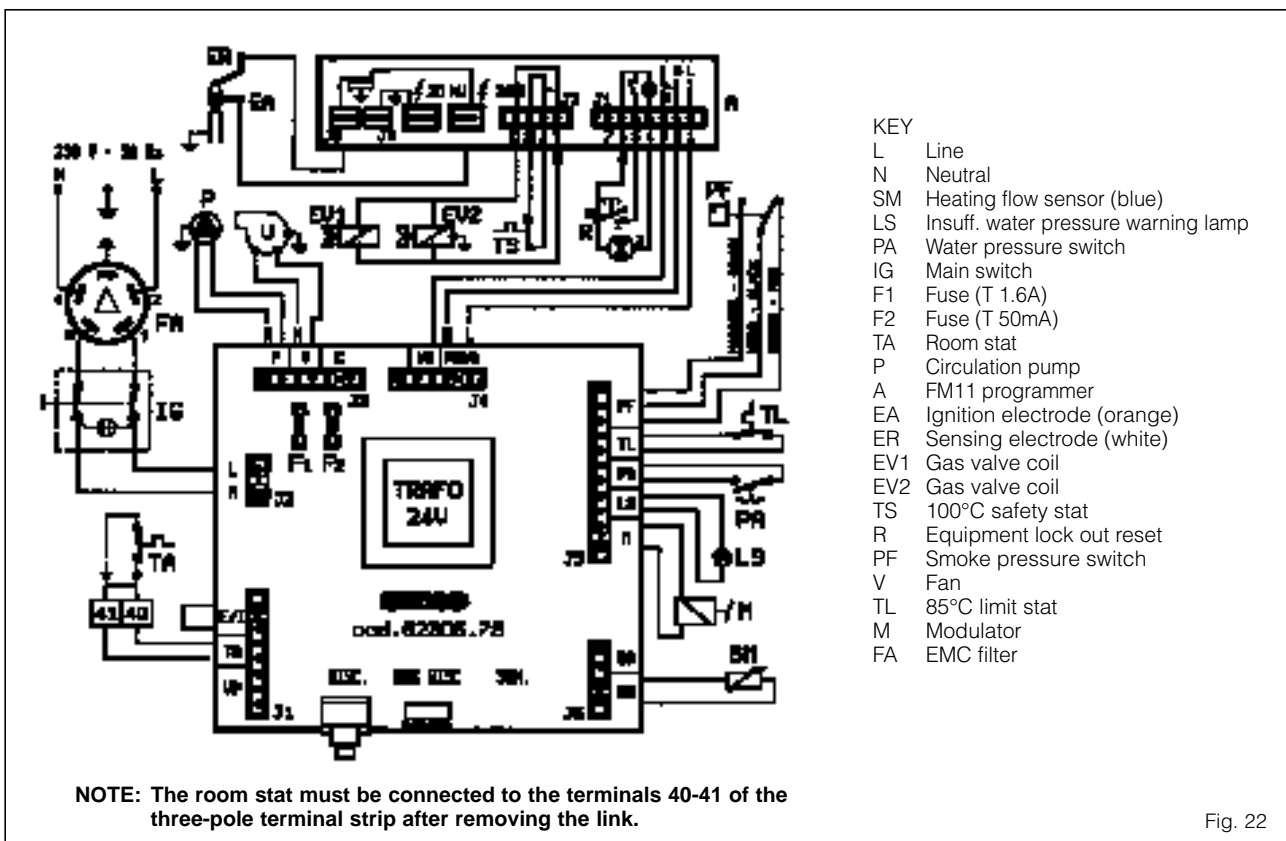

2.12.6 "MURELLE 20 BF CE" wiring diagram

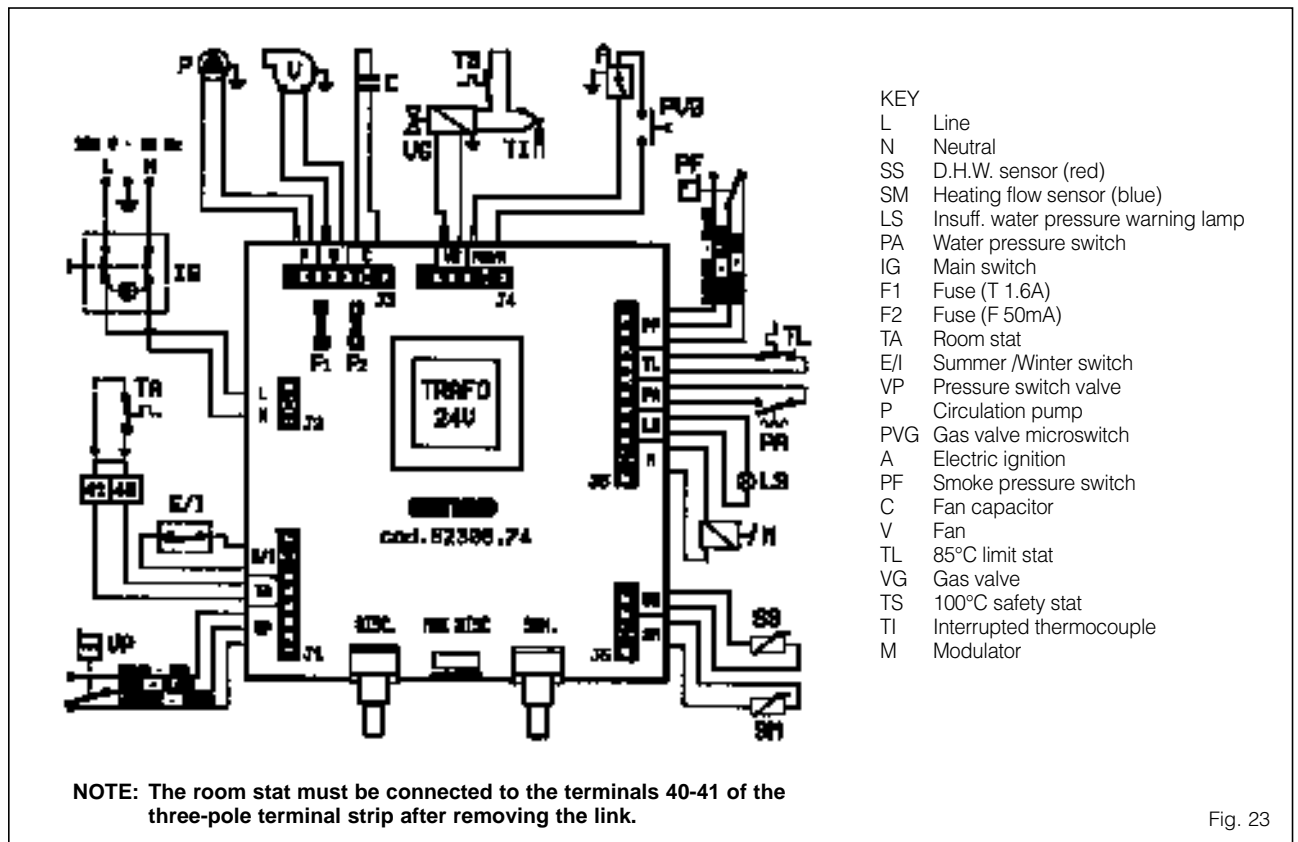

2.12.7 "MURELLE 20 TX CE IONO - MURELLE 20/25 BF CE IONO" wiring diagram

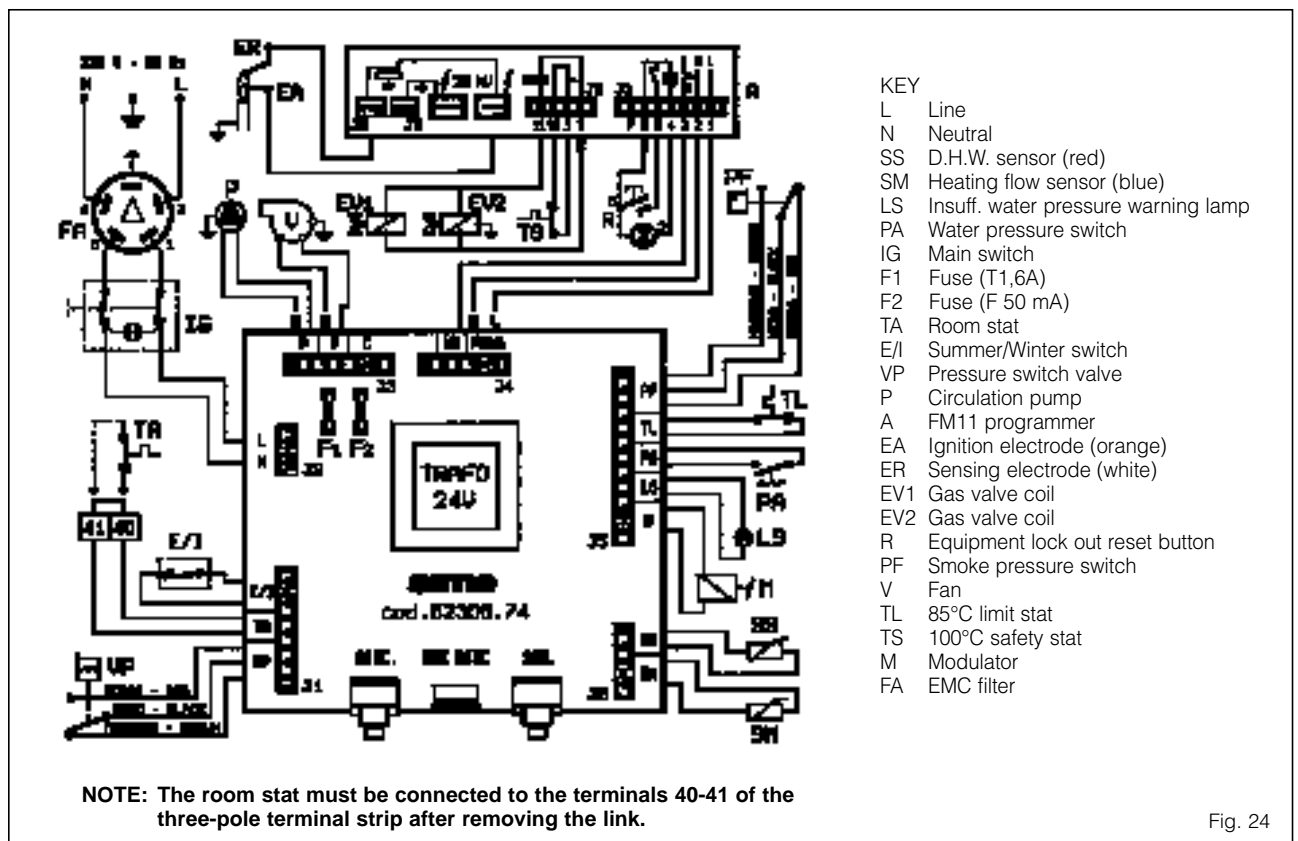

2.13 ELECTRONIC BOARD

The electronic boards of the “MURELLE - MURELLE BF” boilers are manufactured in compliance with the EEC 72/23 low-voltage directives. They are supplied with 230 V and, through a built-in transformer, send a voltage of 24 V to the following components: modulator, water pressure switch, smoke pressure switch and thermostat, D.H.W. and C.H. sensors, room temperature thermostat, “Summer/Winter” switch, and limit thermostat. An automatic and continuous modulation system enables the boiler to adjust the heat output to the various system requirements or the User’s needs. The electronic components are guaranteed to function in a temperature range of -10°C to +60°C.

2.13.1 Central heating operation

Upon demand for heating from the room temperature thermostat, the circulation pump is activated, and approximately 120 seconds must elapse for the burner to start operating. This will happen only if the temperature is set above the value detected by the heating sensor.

The setting range is between 35°C and 80°C. The heat output can be varied according to the system needs by adjusting the trimmer located between the two potentiometers (Section 3.4).

At start-up of each working cycle, after the period of slow ignition having a duration of approx. 8 sec, the boiler will set itself, for 60 sec, at the heat output set on the ‘Minimum heating pressure’ trimmer. Then it will switch to the output set.

At the end of the heating phase, the post-circulation pump will be activated. This lasts 20 sec. and limits the possibility of thermal inertia and recovers the residual calories still present in the primary exchanger.

2.13.2 D.H.W. operation

Upon demand for hot water, the boiler starts instantaneously when the microswitch on the pressure switch valve trips. The required power output is regulated, via flame modulation, by the hot water sensor, which will compare the temperature read with the temperature set on the potentiometer.

The adjustment range is between 35°C and 60°C.

Two limits are set for switching off the boiler:

- when the temperature exceeds 65°C on the D.H.W.;
- when the temperature exceeds 85°C on the heating flow sensor.

In the first case the boiler will be turned back on when the D.H.W. temperature has dropped below 60°C; in the second case, when the heating flow sensor is at 75°C.

2.13.3 Check-Control

The electronic board is equipped with control leds which show some of the possible failures that can cause an irregular and/or improper operation of the appliance.

The leds are arranged on the card as indicated in Fig. 25 and marked with the following wording:

- **SMOKES:** red LED lit up because the fume safety thermostat or the fume pressure switch (“MURELLE 20 TX CE IONO - MURELLE BF” versions) have tripped.
- **REQUEST FOR IGNITION:** green LED lit up on demand for D.H.W. or heating.
- **LINE:** green LED lit up when electric power is reaching the electronic board.
- **SENSORS INTERRUPTED:** red LED lit up because the SM sensor (heating flow sensor) is interrupted; in this case, the boiler operates always at minimum power output in heating.

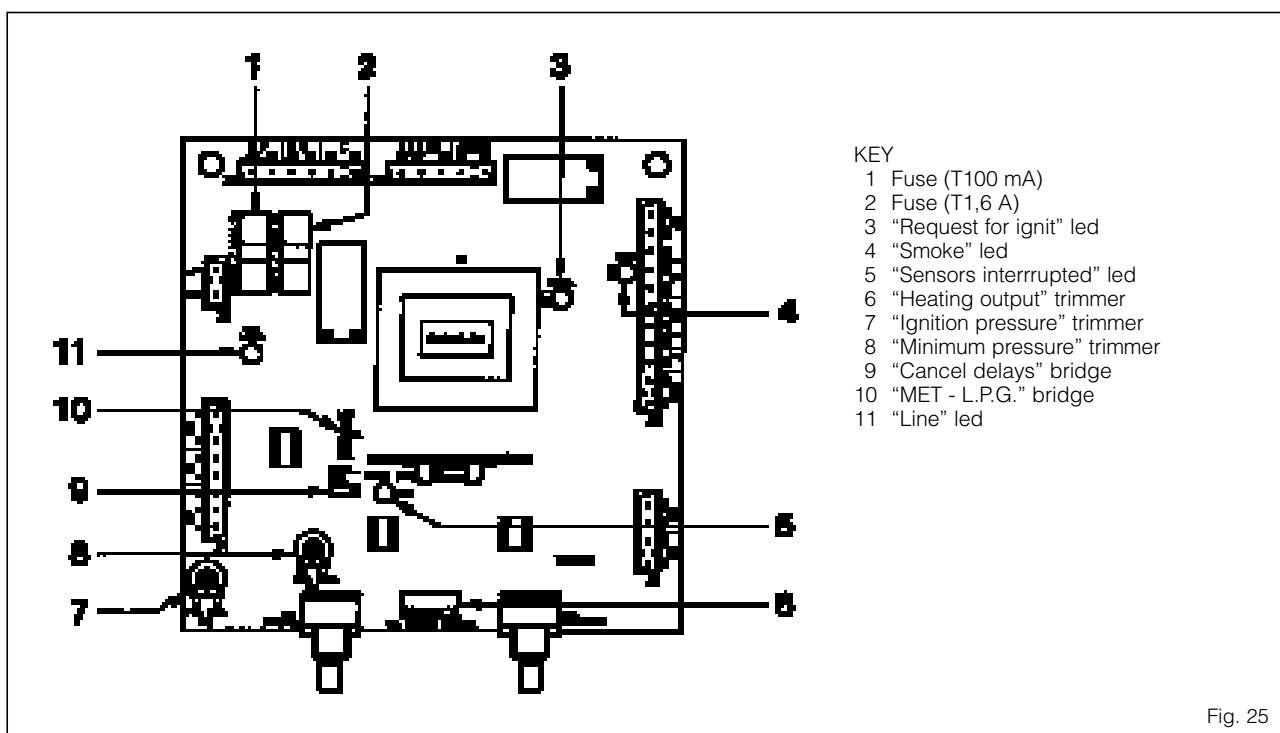

Fig. 25

2.13.4 Devices present on the electronic board

The electronic board of the “MURELLE” boilers is equipped with the following devices:

- “IGNITION PRESSURE” trimmer (7, Fig. 25):
The electronic board has an ‘IGNITION PRESSURE’ trimmer for varying the pressure level upon ignition (STEP) of the gas valve.
According to the type of gas for which the boiler is prepared, the trimmer must be regulated so as to obtain a pressure of approx. 3.5 mbar at the burner for methane gas and 7 mbar for L.P.G.
To increase pressure, turn the trimmer clockwise; to reduce pressure, turn the trimmer counterclockwise.
Fig. 25/a gives an indication of where to set the trimmer according to the type of gas used.
- “MINIMUM HEATING PRESSURE” trimmer (8, Fig. 25/a):
This is the minimum point of modulation in heating to maintain a pressure level higher than the one set for hot water.

NOTE: After setting the pressure level upon ignition (STEP) according to the type of gas, check that the pressure for heating is still at the value previously set.

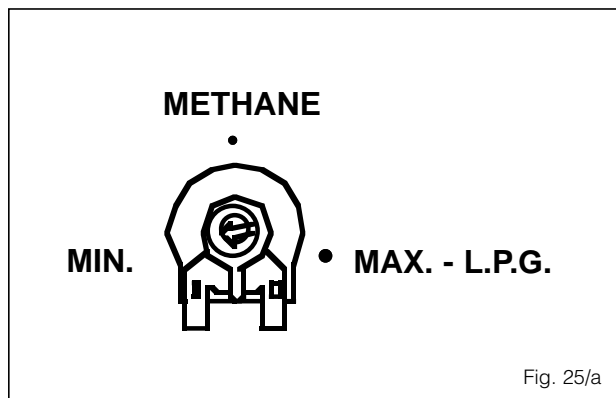

Fig. 25/a

- “MET-L.P.G.” connector (10, Fig. 25):
The connector link must be inserted on the type of gas for which the boiler is prepared.
- “CANCEL DELAYS” connector (9, Fig. 25):
In the heating phase, the electronic board is programmed to include a burner technical delay interval of approx. 2 minutes, which occurs both at system cold starting and at subsequent re-ignitions. The aim is to overcome the problem of repeated ignition and turning off with very short time intervals between. This could occur in particular in systems presenting high head losses. At each restart after the period of slow ignition, the boiler will set itself for about 1 minute at the minimum modulation pressure, and will then move to the heating pressure value set.
When the connecting link is inserted, both the programmed technical pause and the period of operation at minimum pressure in the startup phase will be can-

celled. In this case, the times elapsing between turning off and subsequent re-ignition will depend on a temperature difference of 8°C detected by the SM sensor (heating flow sensor).

NOTE: It is essential that the operations described above be carried out by authorized technical staff; otherwise, the warranty will be rendered null and void.

2.14 TEMPERATURE SENSORS

The “MURELLE” boilers are equipped with sensors for detecting temperature:

- **SM:** heating flow sensor, located on the outlet pipe of the primary exchanger (10, Fig. 3 - 15, Fig. 3/a).
- **SS:** D.H.W. sensor (except for “20 R CE IONO - 2 BFR CE IONO” versions), located on the D.H.W. outlet pipe (2, Fig. 3 - 2, Fig. 3/a).

The sensors are of the NTC type mod. ST03 and are interchangeable. Table 7 shows the resistance values that are obtained on the sensors as the temperature varies.

TABLE 7

Temperature C°	Resistance Ω
20	12.000
30	8.300
35	6.900
40	5.800
45	4.900
50	4.100
55	3.500
60	3.000
70	2.200
80	1.700

NOTE: With the SM heating flow sensor interrupted, the boiler operates in the heating phase always at the minimum heat output, whereas it works normally when generating hot water. If this occurs on the SS hot water sensor, the boiler works always at nominal load and loses flame modulation.

2.15 ELECTRONIC IGNITION

The “IONO” version boilers are provided with automatic ignition (without pilot burner). They are therefore equipped with FM11 electronic control and protection.
Ignition and flame detection is controlled by two electrodes located on the burner.
These guarantee maximum safety with intervention times, for accidental switching off or gas failure, of within one second.

2.15.1 Operating cycle

Before igniting the boiler, use a voltmeter to make sure that the electrical connection to the terminal block has been made properly, respecting the position of line and neutral, as shown in the diagram. Press the switch on the control panel and check for the presence of voltage supply (warning lamp lights up). The boiler is now ready to start working upon demand for heating or drawing off of D.H.W.; a discharge current is sent to the ignition electrode through the FM11 programmer, and the gas valve opens at the same time. Burner ignition normally takes place within 2 or 3 seconds.

However, it is possible for ignition failures to occur, with consequent activation of signal indicating that the equipment has "locked out".

– Gas failure

This may occur upon first ignition or after long periods of boiler lay-off when there is air in the pipes. It may be caused by the gas cock being closed or by one of the valve coils having a break in the winding, so that the valve cannot open.

The appliance runs through the cycle normally sending electric power to the ignition electrode. The electrode continues spark discharge for a maximum of 10 sec. If the burner does not ignite, the equipment "locks out".

– Ignition electrode fails to spark

This may be due to there being a break in the wire to the electrode or to the wire not properly fastened to the equipment electric terminal; or else, the transformer has burnt out.

In the boiler, only the gas to the burner is seen to open. After 10 sec. the equipment "locks out".

– No detection of flame

This occurs when the position of phase and neutral has not been respected on the terminal block.

There is a break in the wire to the sensing electrode or the electrode itself is touching earth: the electrode is worn out and needs replacing.

The continuous spark discharge of the electrode is noted starting from ignition even though the burner is lit. After 10 seconds have elapsed, the sparks cease, the burner goes out, and the warning light indicating equipment "lock-out" lights up.

When there is a sudden voltage failure, the burner shuts out immediately; when power supply returns, the boiler will start up again automatically.

2.16 INTERRUPTION OF THERMOCOUPLE "MURELLE 20 CE - 20 BF CE"

The boiler is equipped with total safety devices, with extinguishing of main burner and pilot if an accidental overtemperature happens in the water-gas exchanger. Control comes about via a limit thermostat (6, Fig. 3 - 7, Fig. 3/a) set at 85°C and a safety thermostat (11, Fig. 3 - 12, Fig. 3/a) set at 100°C, arranged in series in the circuit

of the interrupted thermocouple and overheat cut-off device of the gas valve.

To enable re-ignition of the pilot burner (12, Fig. 3 - 5, Fig. 3/a), so restoring boiler operation, it will be necessary to wait until the temperature in the exchanger drops below the thermostat setting value.

2.17 SMOKE SAFETY DEVICE "MURELLE 20 R CE IONO - 20 CE - 20/25 CE IONO"

This is a safety device against possible smoke emission into the ambience.

The safety device goes into action by blocking operation of the gas valve when the return of smoke into the ambience is continuous and in quantities that might constitute a danger. To enable restart of the boiler, it is necessary first to unscrew the cover of the thermostat and reset the push-button (2, Fig. 18).

Before carrying out this operation, make sure that electric power is not reaching the control panel.

Should the boiler continue to "lock out", it will be necessary to make a careful check on the flue pipe, making all the necessary modifications and adaptations so that it can function efficiently.

2.18 SMOKE PRESSURE SWITCH "MURELLE 20 TX CE IONO - MURELLE BF"

Impurities and possible formations of condensate, which are more likely in cold periods of the year, could cause the pressure switch not to function and the boiler to fail to start. The pressure switch is set in the factory at the optimal values of 4.5 - 6 mm H₂O for the "20 TX - 20 BF" versions, and 8 - 9 mm H₂O for the "25 BF" version. This is able to guarantee operation of the boiler even with air intake and flue outlet pipes at the maximum limit of length allowed.

In the case of replacement, the type of pressure switch originally mounted must be used without fail. Under no circumstances must the pressure switch for the "20 BF" version be installed on the "25 BF" version, since otherwise the safety of operation of the appliance would be jeopardized.

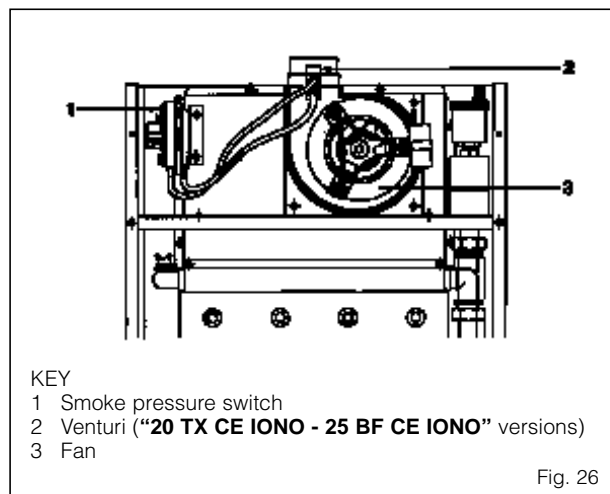

2.19 DISASSEMBLY OF OUTER CASING

To disassemble the outer casing, proceed as follows (Fig. 27):

– pull the front panel forwards so as to release it from

the slot-in pins located on the sides (3) and (4);
– unscrew the screws (1) that fasten the sides to the base and brackets of the smoke chamber;
– push the sides (3) and (4) upwards, sliding them out of their slots.

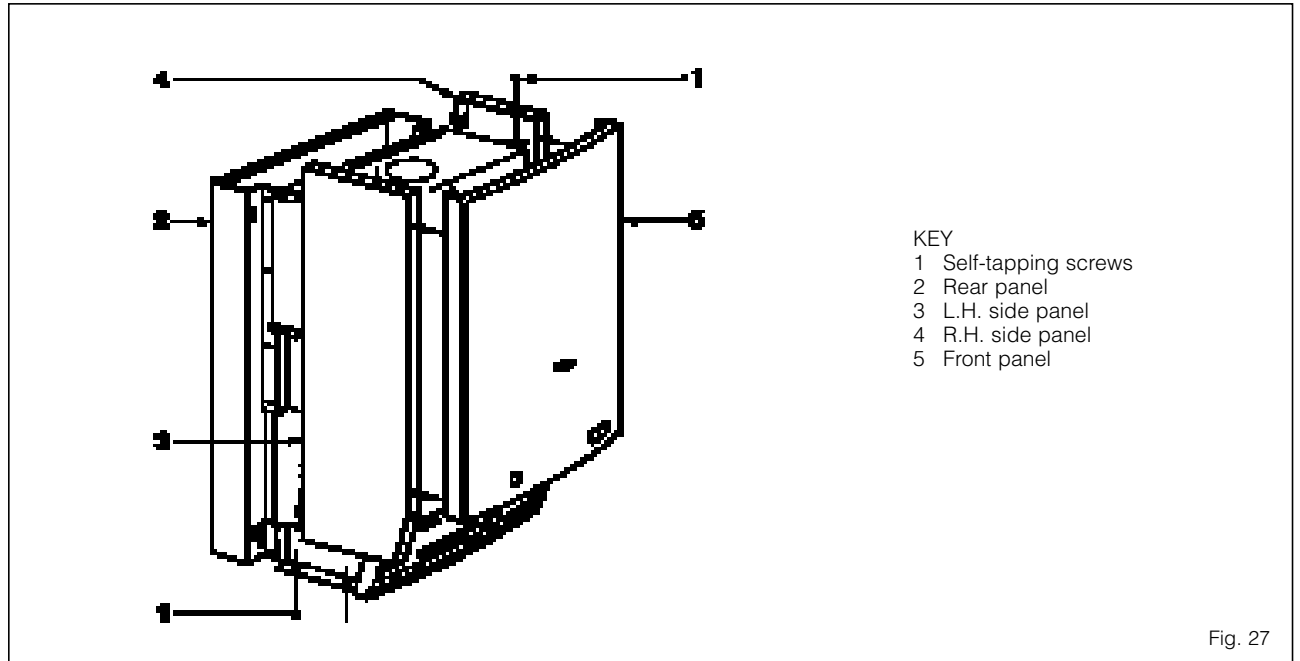

Fig. 27

3 Use and maintenance

3.1 PRELIMINARY CHECKS UPON COMMISSIONING

When carrying out commissioning of the boiler, you are recommended to perform the following checks:

- make sure that the system is charged with water and is thoroughly vented;
- make sure that any shutoff valves are open;
- check that the pipe for expulsion of products of combustion is unobstructed and has been properly installed;
- make sure that the boiler is set for operation for the type of gas supplied;
- open the gas tap and check the soundness of the connections including that of the burner;
- purge the system, bleeding off the air present in the gas pipe by operating the pressure relief valve on the gas valve inlet;
- make sure that the electrical connections have been made correctly and that the earth wire is connected to a good earthing system;
- check that there are no liquids or inflammable materials in the immediate vicinity of the boiler.

3.1.1 Temperature adjustment of D.H.W.

The "MURELLE" boilers (except for "20 R - 20 BFR" models) are equipped with a potentiometer for adjusting the temperature of D.H.W. with a setting range from 35°C to 60°C. This system offers a double advantage:

- 1) the boiler adapts perfectly to any type of D.H.W. system, whether the mixing system is a mechanical or a thermostat-controlled type;
- 2) the thermal output is dosed according to the temperature required, which means a considerable saving in fuel.

NOTE: In order to avoid any misunderstanding please remember that the value obtained by the product of temperature difference (in °C) between D.H.W. output and input into the boiler by the hourly flow rate measured on the tap, where hot water is drawn off (l/h), cannot be higher than the useful output developed by the boiler. For measurements and checks on flow rate and temperature of D.H.W., use suitable instruments, taking into consideration any heat dispersion along the stretch of piping between the boiler and the measuring point.

3.1.2 Adjustment of D.H.W. flow rate

The "MURELLE" boilers (except for "20 R - 20 BFR" models) have a three-way hydraulic valve of the pressure switch type (Fig. 28), which, when at rest, keeps the system delivery flow open, whereas it switches instantaneously to the recirculation position, shutting off heating, upon demand for D.H.W. To adjust the hot water flow rate, use the flow-rate regulator (2) on the pressure switch valve. Remember that the flow rates and corresponding temperatures of use of hot water, given in Table 2, have been obtained by positioning the selector of the circulation pump on the maximum value.

NOTE: Should there be any reduction in the D.H.W. flow rate, the filter (4) installed on the inlet to the pressure switch valve will need cleaning.

To gain access to the filter, first close the shutoff cock for cold water intake located on the fixing jig and then loosen the brass swivel connection (5).

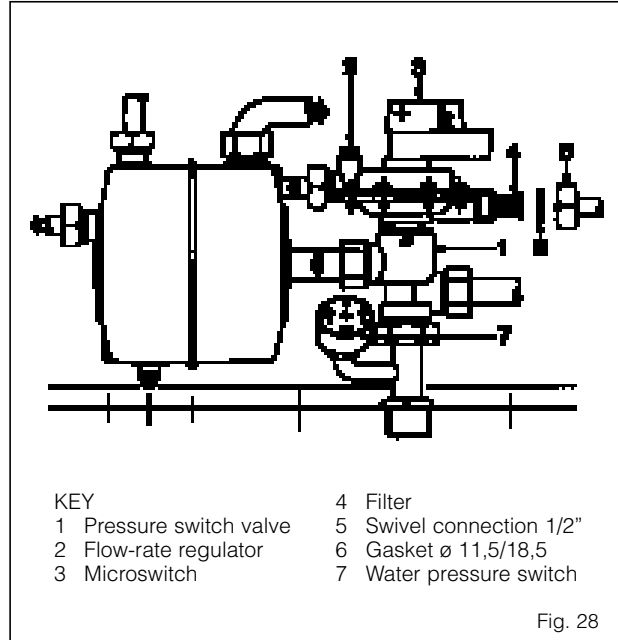

3.2 DISASSEMBLY OF EXPANSION VESSEL

To disassemble the expansion vessel, proceed as follows (Fig. 29):

- make sure that the water has been emptied out of the boiler;
- unscrew the connection (1) connecting the expansion vessel to the boiler;
- unscrew the screw retaining the bracket (5) to the frame assembly, remove the bracket and the expansion vessel (2).

NOTE: Before refilling the system, using a pressure gauge attached to the valve (3) make sure that the expansion vessel is preloaded at a pressure of 0.8 to 1 bar.

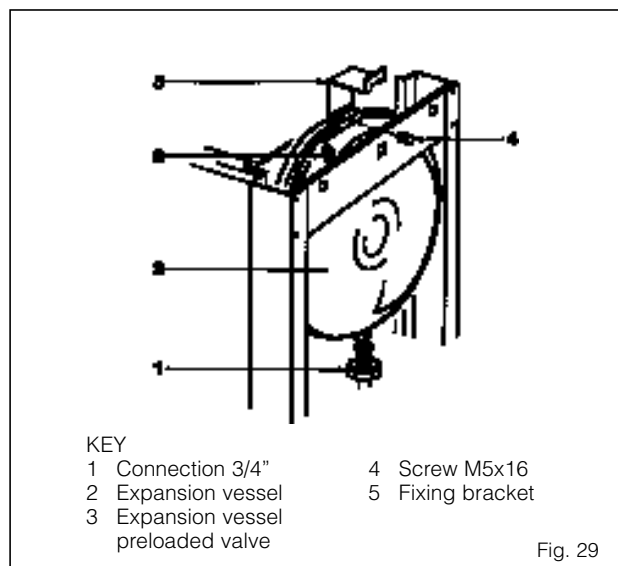

3.3 GAS VALVE

The “MURELLE 20/25 CE - 20 BF CE” boilers are equipped standard with a HONEYWELL V4600N gas valve complete with a modulator screwed onto the pressure regulator (Fig. 30).

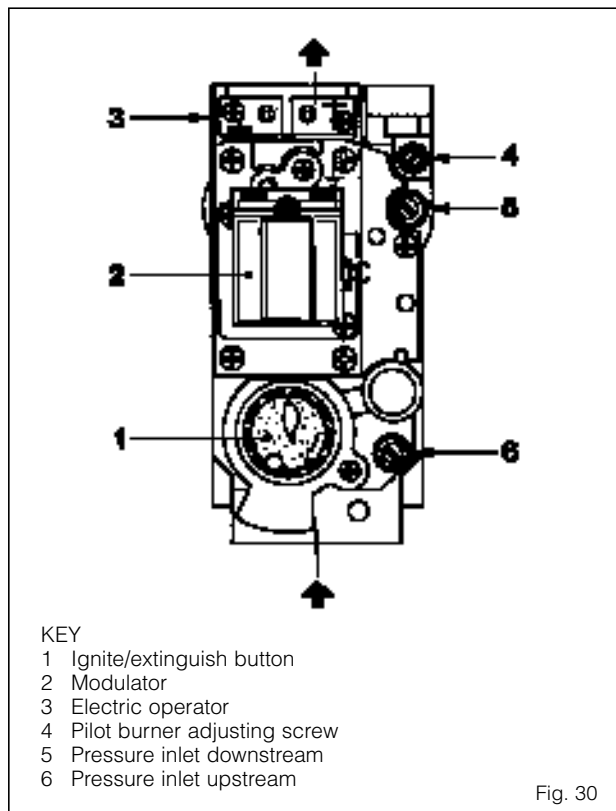

The “MURELLE IONO” versions, without pilot burner, are equipped standard with the SIT 837 TANDEM gas valve (Fig. 30/a).

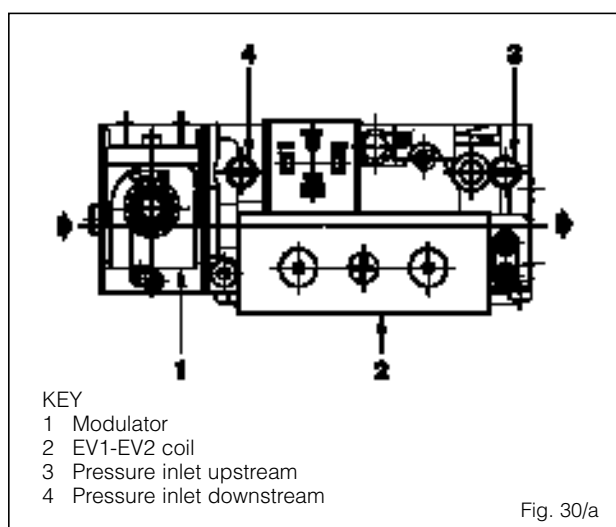

The “MURELLE BF IONO” versions, without pilot burner, are equipped standard with the HONEYWELL VK4105M gas valve (Fig. 30/b).

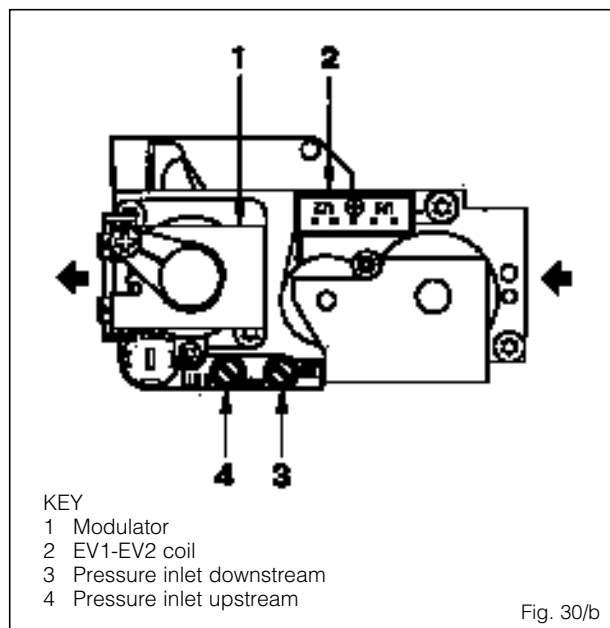

3.4 GAS VALVE ADJUSTMENT

Since all “MURELLE” versions are flame-modulation boilers, they have the gas valve set at two pressure values: maximum and minimum.

According to the type of gas burnt, these correspond to the values given in Table 8. Calibration of the gas pressures at the maximum and minimum values is done by SIME in the factory. Consequently they should not be altered. Only when you switch from one type of gas supply (Natural gas) to another (L.P.G.) it is permitted to alter the operating pressure.

It is essential that this operation be carried out exclusively by authorized technical staff; otherwise, the warranty will be rendered null and void.

When the gas pressures are to be reset, this must be done following a set order: first the maximum pressure and then the minimum for the models equipped with the V4600N and 837 TANDEM gas valve and vice versa for the models equipped with the VK4105 gas valve.

3.4.1 Maximum pressure adjustment V4600N

To set the maximum pressure, proceed as follows (Fig. 31):

- connect the pressure column or a pressure gauge to the pressure inlet downstream of the gas valve;
- remove the retaining spring, completely withdraw the modulator (4) and loosen the locking nut (2);
- tighten the screw (3) and set the knob of the D.H.W. potentiometer to the maximum value (3, Fig. 32).
- ignite the boiler by operating the switch and open the hot water tap;
- using a \varnothing 12 spanner, turn the union (1) to arrive at the maximum pressure value given in Table 8: to reduce the pressure, turn the union counterclockwise; to increase the pressure, turn it clockwise;
- once setted the pressure value tighten the locking nut (2) and replace the modulator (4) in position;
- operate the main switch a number of times, keeping the hot water tap open all the time, and check that the pressure corresponds to the values given in Table 8.

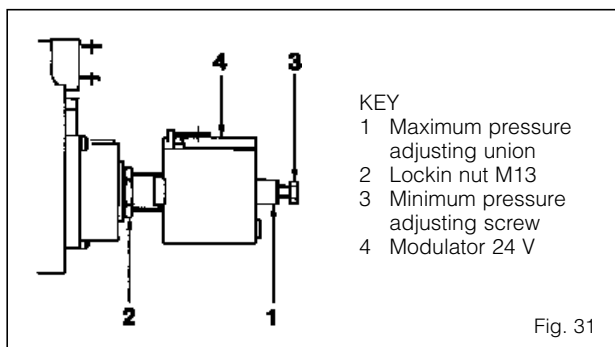

- KEY
- 1 Maximum pressure adjusting union
 - 2 Lockin nut M13
 - 3 Minimum pressure adjusting screw
 - 4 Modulator 24 V

Fig. 31

TABLE 8

Type of gas	Burner	Modulator	Burner	Modulator
	max. pressure mbar	current mA	min. pressure mbar	current mA
Methane - G20	10 - 11	130	2	0
L.P.G. - G30	28	150	7	0
L.P.G. - G31	35	150	7	0

3.4.2 Minimum pressure adjustment V4600N

To set the minimum pressure, proceed as follows (Fig. 31):

- withdraw the modulator (4);
- set the knob of the D.H.W. potentiometer to the maximum value (3, Fig. 32);
- ignite the boiler by operating the switch and open the D.H.W. tap;
- turn the screw (3, Fig. 31) to arrive at the minimum pressure value given in Table 8: to reduce the pressure, turn the screw counterclockwise; to increase the pressure, turn it clockwise;
- replace the modulator (4) in position;
- operate the main switch a number of times, keeping the D.H.W. tap open all the time, and check that the pressure corresponds to the values given in Table 8;
- Fix the modulator with its retaining spring.

3.4.3 Maximum pressure adjustment 837 TANDEM

To set the maximum pressure, proceed as follows (Fig. 31/a):

- connect the pressure column or a pressure gauge to the pressure inlet downstream of the gas valve;
- remove the plastic cap (1);
- set the knob of the D.H.W. potentiometer to the maximum value (3, Fig. 32);
- ignite the boiler by operating the switch and open the hot water tap;
- using a $\varnothing 10$ spanner, turn the nut (3) to arrive at the maximum pressure value given in Table 8: to reduce the pressure, turn the nut counterclockwise; to increase the pressure, turn it clockwise;
- operate the main switch a number of times, keeping the hot water tap open all the time, and check that the pressure corresponds to the values given in Table 8.

3.4.4 Minimum pressure adjustment 837 TANDEM

To set the minimum pressure, proceed as follows (Fig. 31/a):

- disconnect the electric power to the modulator;
- set the knob of the D.H.W. potentiometer to the maximum value and open the hot water tap;
- ignite the boiler by operating the switch and turn the screw (2) keeping locked the nut (3) to arrive at the minimum pressure value given in Table 8: to reduce the pressure, turn the screw counterclockwise; to increase the pressure, turn it clockwise;
- operate the main switch a number of times, keeping the D.H.W. tap open all the time, and check that the pressure corresponds to the values given in Table 8;
- restore electric power to the modulator and replace the plastic cap (1) in position.

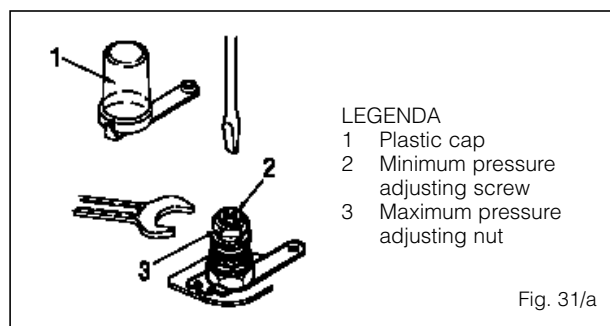

- LEGENDA
- 1 Plastic cap
 - 2 Minimum pressure adjusting screw
 - 3 Maximum pressure adjusting nut

Fig. 31/a

3.4.5 Minimum pressure adjustment VK4105M

To set the minimum pressure, proceed as follows (Fig. 31/b):

- connect the pressure column or a pressure gauge to the pressure inlet downstream of the gas valve;
- disconnect the electric power and remove the plastic cap on the modulator (1);
- set the knob of the D.H.W. potentiometer to the maximum value (3, Fig. 32);
- ignite the boiler by operating the switch and open the D.H.W. tap at a high flow rate;
- using a $\varnothing 9$ spanner, turn the nut (2) to arrive at the minimum pressure value given in Table 8: to reduce the pressure, turn the nut counterclockwise; to increase the pressure, turn it clockwise;
- operate the main switch a number of times, keeping the D.H.W. tap open all the time, and check that the pressure corresponds to the values given in Table 8;
- restore electric power to the modulator.

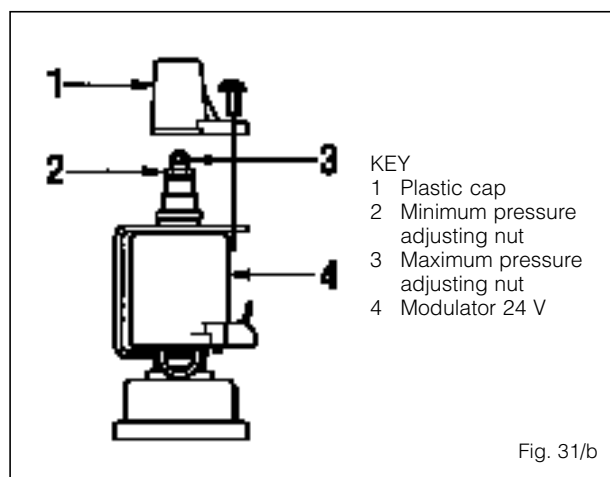

- KEY
- 1 Plastic cap
 - 2 Minimum pressure adjusting nut
 - 3 Maximum pressure adjusting nut
 - 4 Modulator 24 V

Fig. 31/b

3.4.6 Maximum pressure adjustment VK4105M

To set the maximum pressure, proceed as follows (Fig. 31/b):

- set the knob of the D.H.W. potentiometer to the maximum value (3, Fig. 32);
- ignite the boiler by operating the switch and open the D.H.W. tap at a high flow rate;
- using a $\varnothing 7$ spanner turn the nut (3, Fig. 31/b) to arrive at the maximum pressure value given in Table 8: to reduce the pressure, turn the screw counterclockwise; to increase the pressure, turn it clockwise;
- operate the main switch a number of times, keeping the D.H.W. tap open all the time, and check that the pressure corresponds to the values given in Table 8;

3.5 ADJUSTMENT OF HEAT OUTPUT FOR HEATING

To adjust boiler heat output for heating purposes, i.e., modifying the setting made at the factory, which is approximately 16 kW in the “20” vers. , 18 kW in the “25 CE - 25 CE IONO” vers. and 19 kW in the “25 BF CE IONO” vers. use a screwdriver to adjust the heating heat output trimmer (2, Fig. 32).

To increase working pressure, turn the trimmer clockwise (towards the + sign); to reduce pressure, turn the trimmer counterclockwise (towards the – sign).

When the temperature read by the sensor corresponds to the value selected on the potentiometer, the boiler will already be at minimum burner flame. At this point, the potentiometer will cause the burner to go out. To facilitate the operations of adjusting heat output, see the pressure/heat output diagrams for natural gas (methane) and butane or propane gas, shown in figs. 33 and 34.

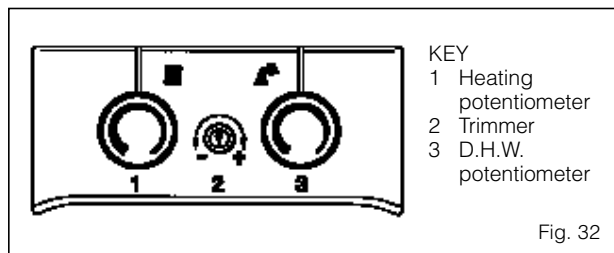

Fig. 32

3.5.1 Pressure/heat output diagram for natural gas

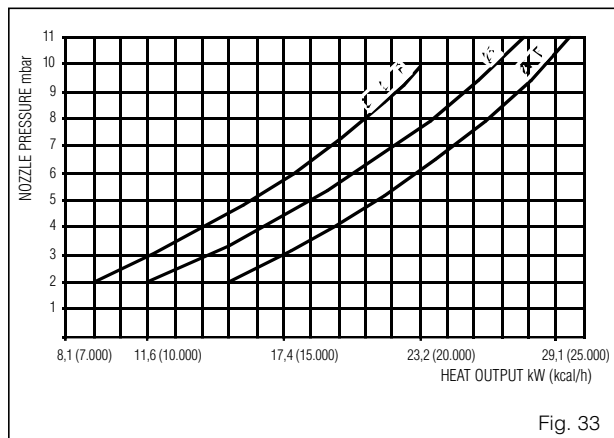

Fig. 33

3.5.2 Pressure/heat output diagram for L.P.G. gas (G30)

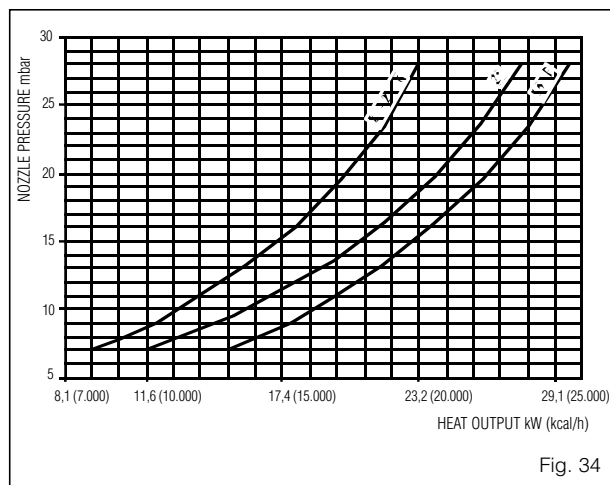

Fig. 34

3.5.3 Pressure/heat output diagram for L.P.G. gas (G31)

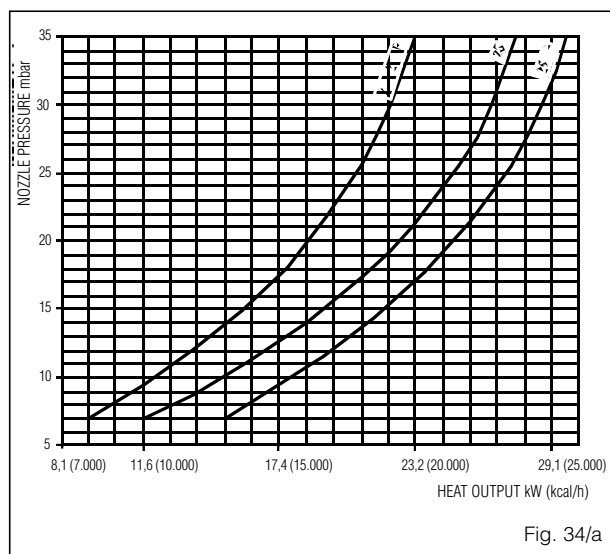

Fig. 34/a

3.6 PILOT BURNER ADJUSTMENT

The “MURELLE 20 CE - 20 BF CE” versions are equipped with pilot flame which, provided it is properly adjusted, should envelop the end portion of the thermocouple over a length of 8 to 10 mm. Adjustment is made by turning the adjusting screw (4, Fig. 30):

- to reduce gas flow, turn the screw clockwise;
- to increase gas flow, turn the screw counterclockwise.

3.7 CONVERSION TO DIFFERENT GAS

To convert to butane gas (G30) or propane gas (G31), first replace the main nozzles and the pilot nozzle (“MURELLE 20 CE - 20 BF CE” versions).

Proceed as follows (Fig. 35):

- close the gas cock;
- in the “MURELLE 20 CE - 20 BF CE” versions, unscrew the interrupted thermocouple (6) and the pilot feed pipe connection (3), and remove the ignition electrode (5);

- remove the pilot burner (8), and replace the pilot nozzle (4);
- slide out the burner unit (11);
- replace the main nozzles (12) located on the burner manifold (9), inserting the copper washer (10). Use a $\varnothing 7$ spanner to perform this operation;
- reassemble all the parts, proceeding in reverse order.
- **In the versions equipped with the V4600N gas valve replace the cylindrical spring (Fig.) of the modulator with the red painted one supplied with the conversion kit.**
- remove the "L.P.G.-MET" connector link on the card (10, Fig. 25) and set it on "L.P.G.";
- to set the values of maximum and minimum gas pressure, follow the instructions given in Section 3.4, according to the type of gas valve used.
Except for making the setting, it is not necessary to perform any other operations on the valve modulator;
- the gas feed pressure must under no circumstances exceed 50 mbar;
- after have ultimated the conversion of the boiler, please stick onto the casing panel the plate showing the relevant feeding gas which is included into the conversion kit.

NOTE: After assembling all the gas connections, a test for gas tightness must be carried out using soapy water or special products. DO NOT USE NAKED FLAMES.

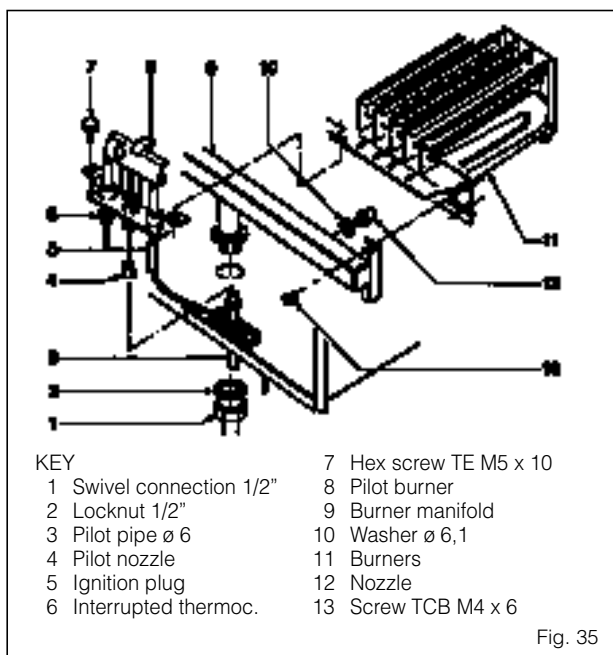

3.8 FILTER ON GAS PIPE

The gas valve used on the "MURELLE" boilers is fitted standard with an inlet filter, which, however, is not able to entrap all the impurities in the gas or in gas mains pipes.

To prevent malfunctioning of the valve, or in certain cases even to cut out the safety device with which the valve is equipped, install an adequate filter on the gas pipe.

3.9 CLEANING AND MAINTENANCE

At the end of each heating season, it is essential to have the boiler thoroughly checked and cleaned out. Proceed as follows:

- turn the main switch off to stop electric power reaching the boiler and close the gas feed cock;
- disassemble the outer casing as described in section 2.19;
- remove the smoke chamber, unscrewing the fixing screws;
- disassemble the gas burner manifold unit, as described in Section 3.7;
- to clean the burner, blow in a jet of air, so as to remove any dust particles that may have accumulated;
- clean the heat exchanger, removing any dust or residue from combustion;
- when cleaning the heat exchanger or the burners, chemical products or steel brushes **MUST NOT BE USED**;
- make sure that the tops of the burners with the holes are free from encrustations;
- during burner disassembly and assembly, be very careful not to exert force on the delicate items, such as the tip of the thermocouple or the ignition and sensing electrodes;
- reassemble the items removed from the boiler, making sure to follow the correct sequence;
- check the chimney to make sure that the flue is clean;
- check operation of the equipment and/or the pilot burner and main burner;
- do not use abrasive products for cleaning the control panel;
- after assembly of all the gas connections, these must be tested for soundness, using soapy water or appropriate products. **DO NOT USE NAKED FLAMES.**

Preventive maintenance and checking of efficient operation of equipment and safety devices must be carried out exclusively by authorized technical personnel.

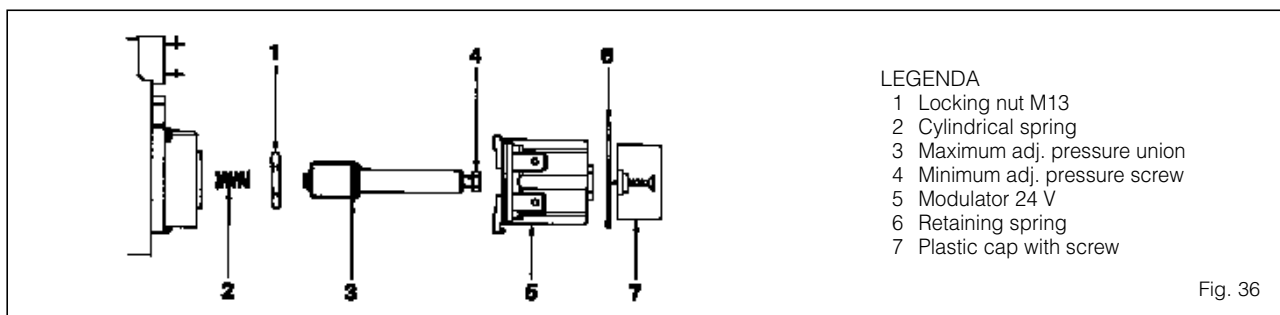

3.10 FAULT FINDING

FAULTS

LIKELY CAUSES AND SOLUTIONS

Pilot fails to light, no discharge spark noted on electrode.

- Check that gas inflow is regular and that all air has been purged from pipes.
- Check the 1.6 Amp fuse is sound.
- Check the micro PVG contact is not faulty; if necessary, replace it (“**BF**” version).
- Check the ignition wire is not faulty and that the contact is good on the connection terminals.
- The electrode may be ill-positioned or require replacement because it is broken.
- Electrical ignition A does not work; replace (“**BF**” version).
- Piezo-ignition does not work; replace.

Pilot burner goes out when ignition button is released.

- Check the pilot flame hits the thermocouple adequately.
- Adjust gas flow to pilot.
- Safety thermostat may be faulty; replace.
- Replace interrupted thermocouple.
- Replace gas valve.

Main burner does not start either to draw off D.H.W. or for heating.

- Check water pressure switch PA; if necessary, replace it.
- The smoke thermostat has tripped; reset it.
- Check whether electric power is reaching the gas valve actuator; check its operation and, if necessary, replace it.
- Check operation of limit thermostat TL and smoke pressure switch PF (“**BF**” version).
- The fan V is operating but at low rpm, so failing to activate the fume pressure switch PF (“**BF**” version); replace fan.
- If, notwithstanding the checks listed above, the main burner still fails to start, replace the electronic card.

Boiler turns on, but after 10 seconds “locks out” (“IONO**” version).**

- Check that during electric wiring the position of line and neutral have not been inverted.
- Check whether the equipment has a burnt fuse.
- Sensing electrode is faulty; replace.
- Equipment is faulty; replace.

Gas valve fails to modulate in D.H.W. phase.

- SS sensor is interrupted; replace.
- Modulator M has a break in winding; replace
- Electronic card is faulty; replace.

Gas valve works only at minimum heat output in heating phase.

- SM sensor is interrupted; replace.

Main burner fails to start in D.H.W. generation phase.

- Check that the pressure switch valve piston moves properly activating microswitch at end of stroke. If this does not happen, check that the water pressure corresponds to the minimum specified; if necessary, replace pressure switch valve.
- The microswitch of the pressure switch valve is faulty; replace it.

D.H.W. arrives very hot but at low flow rate.

- Unscrew completely the screw (2, Fig. 28) of the pressure switch valve.
- Check that the filter (4, Fig. 28) on the pressure switch valve inlet is clean.
- Mains water charge pressure is too low; install water-lift system to provide adequate static head.

D.H.W. taps run neither hot water nor cold.

- Exchanger or D.H.W. outlet pipe obstructed by lime deposits; remove encrustations.

D.H.W. potentiometer or heating potentiometer fails to regulate properly.

- Check that the sensor in question is in contact with the pipe; use silicone paste to improve sensitivity.
- The sensor in question is faulty; replace.

Boiler is noisy or heat exchanger makes a sizzling sound.

- Check whether circulation pump P is obstructed; if necessary clear it out.
- Unclog impeller of circulation pump, clearing away any impurities or sediments.
- Circulation pump is burnt out or has a lower rpm than required; replace.
- Check boiler output is adequate for actual needs of heating system.

Boiler safety valve keeps tripping.

- Check charge cock is closed. If it doesn't close properly, replace.
- Check system cold charge pressure is not too high; keep to recommended values.
- Check whether safety valve is out of calibration; if necessary, replace.
- Check whether the vessel is sufficiently capacious to contain the water for the system.
- Check preloading pressure of expansion vessel.
- Replace expansion vessel if faulty.

Radiators fail to heat up in winter.

- “Summer/Winter” switch is on “Summer”; switch to “Winter”.
- Room temp. thermostat TA is set too low or needs replacing because faulty.
- Electrical connections of room temp. thermostat TA are wrong.
- Microswitch of pressure switch valve is faulty; replace.

Main burner burns badly: flames too high, too yellow.

- Check that pressure of burner gas is regular.
- Check burners are clean.
- Check coaxial assembly has been installed correctly (“BF” version)

Smell of unburnt gases.

- Check boiler is properly clean.
- Check draught is sufficient.
- Check gas consumption is not too high.

Boiler operates but does not increase temperature.

- Check gas consumption is not lower than it should be.
- Check boiler is clean.
- Check boiler is sized in proportion to system.

In the “MURELLE BF CE” vers., with switch ON, fan fails to turn at min speed.

- Check electrical connections and whether electric power is arriving.

In the “MURELLE BF CE” version, upon demand for D.H.W. or heating, fan fails to turn at max speed.

- Check capacitor C; if faulty, replace.
- Replace fan.

In the “MURELLE 20 TX CE IONO” vers., the fan turns but the burner does not start.

- Make sure the smoke pressure switch PF is working and that the corresponding contact is in rest condition.
- Check whether connection tubes of smoke pressure switch PF are obstructed and, if necessary, clean away impurities or condensate.
- Smoke pressure switch PF needs replacing with a new factory-calibrated one.
- Replace electronic board.

In the “MURELLE 20 TX CE IONO” vers., fan fails to turn.

- Check whether connection pipe of smoke pressure switch PF are obstructed and, if necessary, clean away impurities or condensate.
- Smoke pressure switch PF needs replacing with a new factory-calibrated one.
- Check whether electric power is reaching the terminals of the activator motor.
- Motor winding is burnt out; replace.



Fonderie Sime S.p.A. - via Garbo, 27 - 37045 Legnago (Vr)
Tel. 0442/631111 - Fax Serv. Commerciale 0442/631293 - Fax Serv. Tecnico 0442/631292